

INTERNATIONAL
STANDARD

ISO
16792

Second edition
2015-12-01

**Technical product documentation —
Digital product definition data
practices**

*Documentation technique de produits — Données de définition d'un
produit*



Reference number
ISO 16792:2015(E)



COPYRIGHT PROTECTED DOCUMENT

© ISO 2015, Published in Switzerland

All rights reserved. Unless otherwise specified, no part of this publication may be reproduced or utilized otherwise in any form or by any means, electronic or mechanical, including photocopying, or posting on the internet or an intranet, without prior written permission. Permission can be requested from either ISO at the address below or ISO's member body in the country of the requester.

ISO copyright office
Ch. de Blandonnet 8 • CP 401
CH-1214 Vernier, Geneva, Switzerland
Tel. +41 22 749 01 11
Fax +41 22 749 09 47
copyright@iso.org
www.iso.org

Contents

	Page
Foreword	vi
Introduction	vii
1 Scope	1
2 Normative references	1
3 Terms and definitions	2
3.1 General.....	2
3.2 Classification codes for drawings and data sets (see Annex A).....	2
4 Data set identification and control	3
4.1 General.....	3
4.2 Related data.....	3
4.3 Data management.....	4
5 Data set requirements	5
5.1 General.....	5
5.1.1 Fundamental requirements.....	5
5.1.2 Design model requirement.....	6
5.2 General model requirements.....	6
5.2.1 Associativity.....	6
5.2.2 Model coordinate systems.....	6
5.2.3 Applications of supplemental geometry.....	7
5.2.4 Workpiece features not fully modelled.....	8
5.3 General method requirements.....	8
5.3.1 Data set methods.....	8
5.3.2 Model-only.....	8
5.3.3 Model and drawing.....	8
5.4 Management data.....	9
5.4.1 General.....	9
5.4.2 Management data in the data set.....	9
5.4.3 Management data on a model.....	9
5.5 Protection marking.....	10
5.5.1 General.....	10
5.5.2 Location on models.....	10
5.6 Views on models.....	10
6 Design model requirements	12
6.1 General.....	12
6.2 Geometric scale, units and precision.....	12
6.3 Model completeness.....	12
6.4 Assembly model completeness.....	13
6.5 Installation model completeness.....	13
7 Common requirements for product definition data	13
7.1 General.....	13
7.2 Common requirements.....	14
7.2.1 Display management.....	14
7.2.2 Screen dump.....	16
7.3 Model requirements.....	16
7.3.1 General.....	16
7.3.2 Associativity.....	18
7.3.3 Attributes.....	20
7.3.4 Annotation planes.....	22
7.3.5 Leader lines.....	24
7.3.6 Direction-dependent tolerances.....	24
7.3.7 Indicating limited application of a tolerance.....	24
7.3.8 Query types.....	24

7.4	Drawing requirements.....	29
7.4.1	General.....	29
7.4.2	Orthographic views.....	32
7.4.3	Axonometric views.....	32
8	Notes and special notations.....	34
8.1	Common requirements.....	34
8.2	Model requirements.....	34
8.3	Drawing requirements.....	35
9	Model values and dimensions.....	35
9.1	General.....	35
9.2	Common requirements.....	35
9.2.1	Model value queries.....	35
9.2.2	Resolved dimensions.....	35
9.2.3	Plus and minus tolerances.....	36
9.3	Model requirements.....	36
9.3.1	General.....	36
9.3.2	Theoretically exact and nominal dimensions.....	36
9.3.3	Size values.....	37
9.3.4	Coded size tolerances.....	38
9.3.5	General applications of plus and minus tolerances.....	38
9.3.6	Chamfers.....	38
9.3.7	Depth specification.....	42
9.4	Drawing requirements.....	45
10	Datum applications.....	45
10.1	General.....	45
10.2	Common requirements.....	45
10.3	Model requirements.....	45
10.3.1	Datum systems and model coordinate systems.....	45
10.3.2	Identification of datums.....	48
10.3.3	Associativity of datum features and design data.....	50
10.3.4	Datum target identification and attachment.....	50
10.3.5	Multiple features establishing a datum.....	52
10.4	Drawing requirements.....	57
11	Geometric tolerances.....	58
11.1	General.....	58
11.2	Common requirements.....	58
11.3	Model requirements.....	58
11.3.1	General.....	58
11.3.2	Form tolerances.....	58
11.3.3	Orientation tolerances.....	65
11.3.4	Profile tolerances.....	72
11.3.5	Location tolerances.....	80
11.3.6	Runout tolerances.....	87
11.4	Drawing requirements.....	94
11.4.1	General.....	94
11.4.2	Requirements applicable to all geometric tolerances.....	94
11.4.3	Form tolerances.....	94
11.4.4	Orientation tolerances.....	98
11.4.5	Profile tolerances.....	98
11.4.6	Position tolerances.....	101
11.4.7	Runout tolerances on a drawing.....	101
12	Welds.....	101
12.1	General.....	101
12.2	Common requirements.....	101
12.2.1	Application of supplemental geometry.....	101
12.2.2	Arrow lines.....	101

12.3	Model requirements.....	102
12.3.1	Annotation plane.....	102
12.3.2	Associativity.....	102
12.3.3	Indicating extents of the weld.....	102
12.3.4	Query of weld path.....	104
12.4	Drawing requirements.....	105
13	Surface texture.....	105
13.1	General.....	105
13.2	Common requirements.....	105
13.3	Model requirements.....	105
13.3.1	Display techniques.....	105
13.3.2	Annotation plane.....	106
13.3.3	Associativity.....	106
13.3.4	Indication of direction of lay.....	106
13.3.5	Use of all around indication.....	107
13.4	Drawing requirements.....	108
Annex A (informative) Classification codes for drawings and data sets.....		109
Bibliography.....		111

Foreword

ISO (the International Organization for Standardization) is a worldwide federation of national standards bodies (ISO member bodies). The work of preparing International Standards is normally carried out through ISO technical committees. Each member body interested in a subject for which a technical committee has been established has the right to be represented on that committee. International organizations, governmental and non-governmental, in liaison with ISO, also take part in the work. ISO collaborates closely with the International Electrotechnical Commission (IEC) on all matters of electrotechnical standardization.

The procedures used to develop this document and those intended for its further maintenance are described in the ISO/IEC Directives, Part 1. In particular the different approval criteria needed for the different types of ISO documents should be noted. This document was drafted in accordance with the editorial rules of the ISO/IEC Directives, Part 2 (see www.iso.org/directives).

Attention is drawn to the possibility that some of the elements of this document may be the subject of patent rights. ISO shall not be held responsible for identifying any or all such patent rights. Details of any patent rights identified during the development of the document will be in the Introduction and/or on the ISO list of patent declarations received (see www.iso.org/patents).

Any trade name used in this document is information given for the convenience of users and does not constitute an endorsement.

For an explanation on the meaning of ISO specific terms and expressions related to conformity assessment, as well as information about ISO's adherence to the WTO principles in the Technical Barriers to Trade (TBT) see the following URL: [Foreword - Supplementary information](#)

The committee responsible for this document is ISO/TC 10, *Technical product documentation*.

This second edition cancels and replaces the first edition (ISO 16792:2006), which has been technically revised mainly to incorporate the technical changes in ISO 1101:2012 and ISO 5459:2011. [Clause 12](#) on indication for welds and [Clause 13](#) on indications for surface texture have been added. A new informative annex on classification codes has also been added.

Introduction

Every effort was made during the preparation of the first edition of this International Standard, adapted from ASME Y14.41:2012, to apply existing requirements developed for two-dimensional (2D) presentation equally to the output from three-dimensional (3D) models. Where new geometrical product specification (GPS) rules have proved essential, these have been drafted with a view to their being equally applicable to both 2D and 3D. Therefore, in order to maintain the integrity of a single system, these new rules are being incorporated in the relevant existing ISO standards for cross-reference. Application examples have been included where, due to the specific requirements of 3D modelling, additional guidance was deemed beneficial.

It is recognized that there is a need to support drawings in conjunction with 3D models now and for the foreseeable future. This need has been addressed in this International Standard through the definition of the two methods for documenting digital models and specification of requirements to ensure that the information in a data set is consistent between the model and the drawing.

The figures in this International Standard are intended only as illustrations to aid the user in understanding the practices elaborated in the text. In some cases, figures show a level of detail as needed for emphasis; in others, they are only complete enough to illustrate a concept or facet thereof. The absence of figures has no bearing on the applicability of the specified requirement or practice.

In order to comply with the requirements of this International Standard, actual data sets shall meet the content requirements set forth in its text.

Most figures are illustrations of models in a 3D environment. Figures illustrating drawings in digital format include a border.

Text in uppercase letters used in the figures are intended to appear in digital product definition data, or data sets, while that in lowercase letters is for information only and is not intended to appear in data sets.

Technical product documentation — Digital product definition data practices

1 Scope

This International Standard specifies requirements for the preparation, revision, and presentation of digital product definition data, hereafter referred to as data sets. It supports two methods of application: model-only and model and drawing in digital format. Its structure presents requirements common to both methods followed by clauses providing for any essential, differing requirements for each method. Additionally, its use in conjunction with computer-aided design (CAD) systems could assist in the progression towards improved modelling and annotation practices for CAD and engineering disciplines, as well as serving as a guideline for IT engineers.

The aspects specified in this International Standard refer mainly, but not exclusively, to requirements that differ or are additional to those provided in existing, related standards. Where no such requirements are identified, it is safe to assume that the appropriate existing ISO standards are instead applicable.

2 Normative references

The following referenced documents are indispensable for the application of this document. For dated references, only the edition cited applies. For undated references, the latest edition of the referenced document (including any amendments) applies.

ISO 128 (all parts), *Technical drawings — General principles of presentation*

ISO 129-1:2004, *Technical drawings — Indication of dimensions and tolerances — Part 1: General principles*

ISO 286 (all parts), *Geometrical product specifications (GPS) — ISO code system for tolerances on linear sizes*

ISO 1101:2012, *Geometrical product specifications (GPS) — Geometrical tolerancing — Tolerances of form, orientation, location and run-out*

ISO 1302, *Geometrical Product Specifications (GPS) — Indication of surface texture in technical product documentation*

ISO 2553, *Welding and allied processes — Symbolic representation on drawings — Welded joints*

ISO 3098-1:2015, *Technical product documentation — Lettering — Part 1: General requirements*

ISO 3098-5:1997, *Technical product documentation — Lettering — Part 5: CAD lettering of the Latin alphabet, numerals and marks*

ISO 5456 (all parts), *Technical drawings — Projection methods*

ISO 5457:1999, *Technical product documentation — Sizes and layout of drawing sheets*

ISO 5459:2011, *Geometrical product specifications (GPS) — Geometrical tolerancing — Datums and datum systems*

ISO 7200:2004, *Technical product documentation — Data fields in title blocks and document headers*

ISO 10209:2012, *Technical product documentation — Vocabulary — Terms relating to technical drawings, product definition and related documentation*

ISO 11442:2006, *Technical product documentation — Document management*

ISO 14405-1, *Geometrical product specifications (GPS) — Dimensional tolerancing — Part 1: Linear sizes*

ISO 14405-2, *Geometrical product specifications (GPS) — Dimensional tolerancing — Part 2: Dimensions other than linear sizes*

ISO 16016, *Technical product documentation — Protection notices for restricting the use of documents and products*

ISO 17450-1:2011, *Geometrical product specifications (GPS) — General concepts — Part 1: Model for geometrical specification and verification*

ISO 80000-1, *Quantities and units — Part 1: General*

IEC 82045-2:2004, *Document management — Part 2: Metadata elements and information reference model*

3 Terms and definitions

For the purposes of this document, the terms and definitions in ISO 10209:2012 and the following apply.

3.1 General

3.1.1

absolute coordinate system

primary model coordinate system in the CAD model used to define the location of digital elements in the CAD model

3.1.2

datum system

set of two or more situation features established in a specific order from two or more datum features

Note 1 to entry: To define a datum system, it is necessary to consider the collection surface created by the considered datum features. The invariance class of a collection surface can be complex, prismatic, helical, cylindrical, revolute, planar, or spherical (see ISO 5459:2011, Table B.1).

[SOURCE: ISO 5459:2011, 3.10]

3.1.3

user defined coordinate system

model coordinate system which is created in the CAD model in addition to the absolute coordinate system

3.2 Classification codes for drawings and data sets (see [Annex A](#))

3.2.1

classification code

designation assigned to product definition data that defines what data are included within the drawing, data set, or both

Note 1 to entry: A drawing can either be in physical or electronic format.

3.2.2

classification code 1

drawing with optional data set

Note 1 to entry: Classification code 1 identifies that the data elements are located on the drawing and the drawing is the original.

3.2.3

classification code 2

data set with model and drawing

Note 1 to entry: Classification code 2 identifies that data elements are located on a drawing and the drawing is the original. A computer is used as a tool to prepare the drawing and the model. Data elements are located in the digital data and the drawing.

3.2.4**classification code 3**

data set with model and simplified drawing

Note 1 to entry: Classification code 3 identifies a model with a simplified drawing used to expedite communication of common part features and to define non-geometric part definitions.

3.2.5**classification code 4**

data set with model and drawing

Note 1 to entry: Classification code 4 identifies that all data elements are located in both the digital data and the drawing. The data set is the original.

3.2.6**classification code 5**

data set with model

Note 1 to entry: Classification code 5 identifies that all data elements are located in the data set with model. No drawing exists.

4 Data set identification and control**4.1 General**

Data sets for which compliance with this International Standard is claimed shall include a reference to this International Standard, ISO 16792, either in the data set itself or in a document referenced by the data set.

The current revision of the data and the computer application(s) and version(s) used to develop the data set shall be specified with other management data (see [5.4](#)).

The data set identifier shall be unique and shall consist of numeric, alphabetic, or special characters in any combination. Spaces are not permitted between any of the characters of the data set identifier.

The length of the data set identifier may be a direct function of the computer system and the operating system. When the part or identifying number is used as the data set identifier, the length shall be compatible with recognized limitations on number length in accordance with ISO 7200 and IEC 82045-2.

Special characters, such as hyphen (-), slash (/), or asterisk (*), shall be selected in a manner that does not hinder data set identification or have an adverse effect on the computer system operation.

A recognizable prefix or suffix may be included as part of the identifier to associate files and sets of related data.

See ISO 7200 and IEC 82045-2 for the description and use of drawings, drawing numbers, and identifying numbers.

An optional system for classification codes established to define what data are included within the drawing, data set, or both is presented in [Annex A](#).

4.2 Related data

Related data shall be integral to, or referenced in, the data set. Related data consists of, but is not limited to, analytical data, parts lists, test requirements, material specifications, process, and finish requirements in accordance with [Figure 1](#).

4.3 Data management

The following specifies the structure and control requirements for data management:

- a) The data management system shall meet the requirements of ISO 11442, providing information to enable the control and tracking of data sets, throughout the life cycle of the product to which each relates. The system may include work in process, data review status, model checked status, release status, design tool and version, libraries, etc.
- b) Revision history information per ISO 11442 shall be contained in the data set.

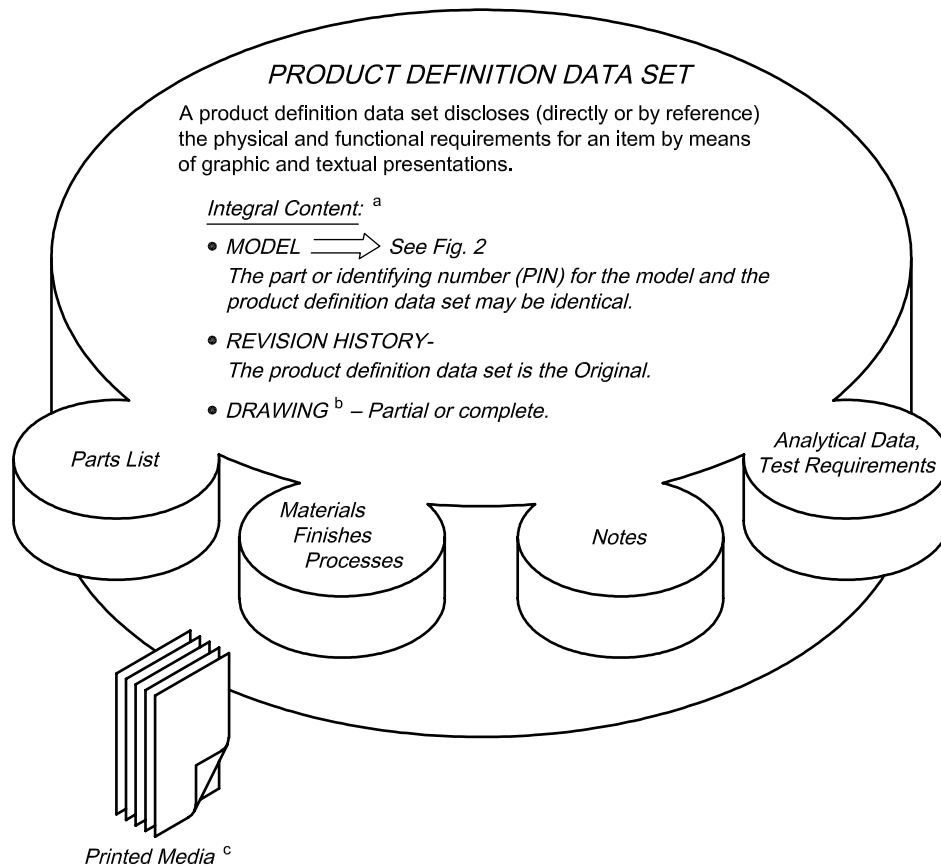

Key

- a Related data (as applicable) required for complete definition may be integral to or referenced in the product definition data set. Data not integral to the product definition data set may be revised independently.
- b A drawing is not required for Model Only data sets.
- c Related data may be manually or computer generated.

Figure 1 — Content of a product definition data set

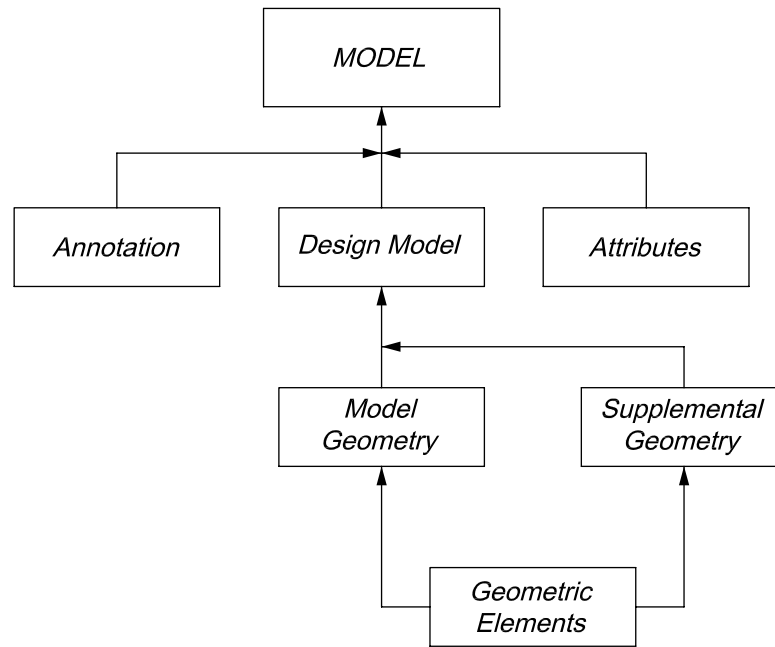

Figure 2 — Content of a model

5 Data set requirements

5.1 General

The data set shall provide complete product definition, for example, a design model, its annotation, and related documentation.

5.1.1 Fundamental requirements

The following are the fundamental requirements and other provisions applicable to both annotated models and drawings, specific to annotated models and specific to drawings.

a) Common to annotated models and drawings

- All model values and resolved dimensions shall be obtained from the model.
- Rounding requirements for resolved dimensions shall comply with [9.2.2](#).
- The ability to query the model shall be available (see [7.3.8](#)).
- All angular values shall be queried from the model (see [9.3](#)). Exceptions to this are model coordinate system(s), planes and axes in a datum system, and orthographic views.
- When query is required, a notation stating the requirement for query of the model or associated data shall be added to the drawing or in the general notes.
- When applying tolerances to features, alignment of the annotation plane to the nominal or theoretically exact profile is not required.
- Values obtained from the model for any feature(s) without any tolerance or datum target specifications assigned shall be auxiliary dimensions.
- Legibility requirements of ISO 3098-1 and ISO 3098-5 shall apply when the annotation is viewed perpendicular to the annotation plane.

- Annotation in any given annotation plane shall not overlap other annotation in the same annotation plane when the model is viewed perpendicular to the annotation plane.
- Annotation text within any given annotation plane shall not be placed over the design model when the model is viewed perpendicular to the annotation plane.

b) **Applicable only to models**

- All annotation shall be specified in one or more annotation planes. When CAD software does not support maintenance of annotation plane orientation relative to the model, the model-only method shall not be used (see [7.3.4](#)).
- The associated entities, annotation, and attributes shall be in agreement (see [7.3.2](#)).
- Resolved dimensions created from queried model values are considered the same as dimensions displayed on a model (see [9.2.1](#)).
- Display of centrelines or centre planes for features of size is optional.
- To ensure that the annotation is readable — the text, for example, could be upside down or backwards following rotation of the model — one of the following techniques shall be used:
 - a) ensuring that the reading direction is updated after rotation of a model;
 - b) inclusion of means of determining the correct reading direction in each annotation plane applied to a model;
 - c) when using saved views, ensuring that the model is orientated in the intended view direction — for example, by including a means of determining the correct reading direction in the view.
- Dimensions and tolerances to internal features can be shown without the use of a section [see [Figure 25 c](#)].

c) **Applicable only to drawings**

- Annotation may be applied to orthographic or axonometric views.
- For axonometric views, the orientation of the annotation shall be parallel to, normal to, or coincident with the surface to which it applies. An annotation shall not overlap another or the geometrical representation of the part.

5.1.2 **Design model requirement**

A design model is required and shall be in accordance with [5.2](#) and [Clause 6](#).

5.2 **General model requirements**

5.2.1 **Associativity**

The ability to associate digital elements shall be available and maintained. Associativity information shall be electronically accessible.

5.2.2 **Model coordinate systems**

A design model shall contain one or more model coordinate systems. A model coordinate system shall be depicted by three mutually perpendicular line segments with its origin located at the intersection of

the three axes. Each axis shall be labelled and the positive direction shown. Model coordinate systems shall be right-handed unless otherwise specified [see [Figure 3 b](#)].

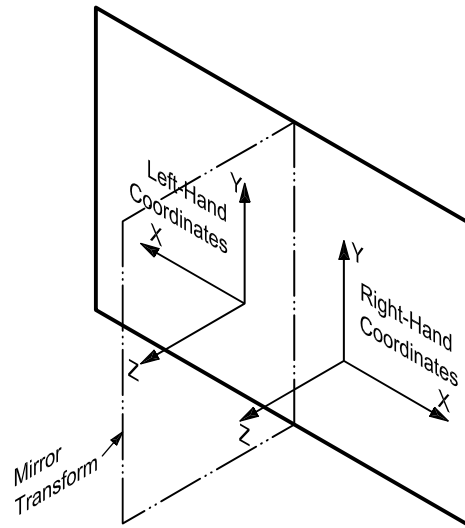

a) Mirror-image relationship

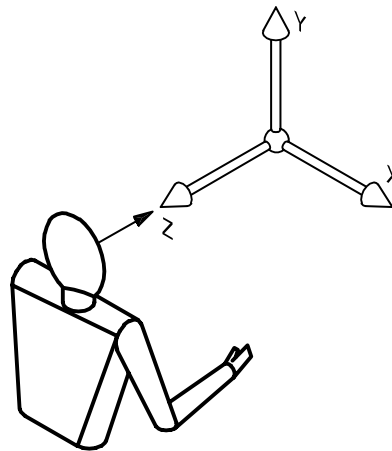

b) Recognizing the right-hand coordinate system

NOTE When observed in the Z direction, with positive Y ascending, positive X is directed to the right-hand side of the observer.

Figure 3 — Left- and right-hand model coordinate systems

5.2.3 Applications of supplemental geometry

When supplemental geometry is used, there shall be a clear distinction between the supplemental geometry and the model geometry.

a) Represented line element

When a represented line element is used to indicate the direction of a geometric tolerance application, the leader line from the tolerance frame shall terminate on the represented line element in an arrowhead (see [Figure 41](#)). The following geometric tolerances can use a represented line element to clarify the directionality of a two-dimensional tolerance zone of parallel lines:

- straightness applied to the line elements of a planar surface (see [11.3.2](#) and [Figure 41](#));

- orientation tolerance applied on each line element on a surface (see [11.3.3](#) and [Figure 47](#)).
- profile any line (see [11.3.4](#) and [Figure 56](#)).

NOTE It might be necessary to carefully define the placement and orientation of the represented line element on the real workpiece.

b) Associativity

The represented line element, the tolerance frame, and the tolerated model feature should be organized as an associated group (see [Figures 41, 47, and 56](#)).

5.2.4 Workpiece features not fully modelled

A conventional simplified representation of workpiece features such as threads, holes, fillets, rounds, and drafts can be shown using partial geometry definition, annotations, attributes, or a combination thereof (see [Figure 10](#)).

5.3 General method requirements

5.3.1 Data set methods

The following subclauses cover the product definition methods listed below. Each different method for specifying product definition is used in support of different industry processes and requirements. The data set is the original for all of the methods: any copy, no matter what the media of presentation, is subordinate.

5.3.2 Model-only

The following is applicable when there is complete product definition within a model.

- a) Product definition data, including but not limited to notes, parts lists, marking requirements, dimensions, and tolerances, shall be contained or referenced in the data set.
- b) The data elements of a drawing format as defined in ISO 5457 and ISO 7200 are not required, except for the following, which shall be contained in the data set:
 - legal owner for the data set;
 - data set title;
 - data set number;
 - approval indicators and approval dates;
 - contract number when required;
 - originator's name and date.
- c) When working with a model, the first or third angle projection symbol (see ISO 5456-2) is not required.

5.3.3 Model and drawing

The following is applicable when there is complete product definition within a model and drawing.

- a) A complete definition of a product shall contain a model and a drawing that may contain orthographic views, axonometric views, or a combination thereof. Annotation may be applied to the model or on the drawing or a combination thereof.

NOTE The development of a drawing that provides a complete product definition is allowed.

- b) Product definition data created or shown in the model and on the drawing shall not be in conflict.
- c) Product definition data created and shown on the drawing shall not conflict with product definition data in the model.
- d) The drawing shall contain a drawing border and title block information in accordance with ISO 5457 and ISO 7200.
- e) The drawing shall reference all models and data relevant to the product.
- f) Annotation displayed on the drawing shall be interpretable without the use of query.
- g) When complete product definition is not contained on the drawing, this shall be noted.
- h) When complete product definition is not contained in the model, this shall be noted.

5.4 Management data

5.4.1 General

Management data that is not placed on a drawing shall be placed on the model or in the data set separate from the model or drawing according to [5.4.2](#) and [5.4.3](#).

5.4.2 Management data in the data set

The following management data shall be contained in the data set:

- application data;
- approval;
- data set identification;
- design activity transfer;
- revision history for the data set.

5.4.3 Management data on a model

Management data placed on a model shall be placed on a management data annotation plane or using an equivalent method. The annotation plane shall be available for display with the model. When displayed, the management data annotation plane shall not rotate with the model. Management data placed on a model shall include, but is not limited to

- ISO 16792,
- CAD-maintained notation,
- design activity identification,
- duplicate original notation,
- item identification,
- unit of measurement, and
- navigation data.

5.5 Protection marking

5.5.1 General

Protection marking shall be placed in the file(s) or in the referenced document(s) to which it applies (see ISO 16016).

5.5.2 Location on models

Protection marking shall be placed on a protection-marking annotation plane, or equivalent, which shall be available for display with the model. Reproductions of technical data, or any portions thereof, subject to asserted restrictions shall also reproduce the asserted restrictions. When displayed, the protection-marking annotation plane does not rotate with the model.

NOTE Models containing company intellectual property could include notes to this effect, such as company proprietary notes and competition-sensitive material. In addition, there could be requirement for the inclusion of other information such as government notices, statements, and legends. Contractual requirements (copyright notices, distribution statements, export control notices and rights in data legends, etc.) determine precisely what is required.

5.6 Views on models

See ISO 128-30, ISO 128-34, ISO 128-40, ISO 128-44, and ISO 128-50 for sections and views. The following paragraphs describe exceptions or additions for views on models.

a) Saved views

Saved views of a design model may be defined to facilitate presentation of the model and its annotation. A saved view shall have an identifier, be retrievable on demand, contain a model coordinate system that denotes the direction of the view relative to the model, and may contain one or more of the annotation plane(s), a selected set of annotation, or a selected set of geometry.

b) Sections

Saved views can be used to retain sections. All sections shall have the same scale as the design model.

- 1) A representation of a cutting plane shall be used to indicate the location and viewing direction of a section. The edges of the cutting plane shall be continuous or long-dashed dotted narrow lines, in accordance with ISO 128-20. A means of identifying all cutting planes in a model shall be available. A visible-view arrow or arrows shall be included to show the direction in which the section is viewed (see [Figure 4](#)). A capital letter or letters shall be used for the identification of the cutting plane as indicated in ISO 128-40.
- 2) The result of the section cut may be shown either by removing material from the part [see [Figure 4 b](#))] or by display of the curves overlaid on the model that result from intersecting the cutting plane with the part [see [Figure 4 c](#))].
- 3) Multiple connected cutting planes shall be used for offset sections (see [Figure 5](#)).
- 4) Aligned sections, removed sections, and revolved sections shall not be used on design models.
- 5) Broken-out sections shall be accomplished as offset sections [see also 2) above].
- 6) Foreshortened and aligned features, as well as rotation of features, shall not be used on design models.
- 7) Section views shall be derived from the design model. Changes to the design model shall cause section views to be updated accordingly.

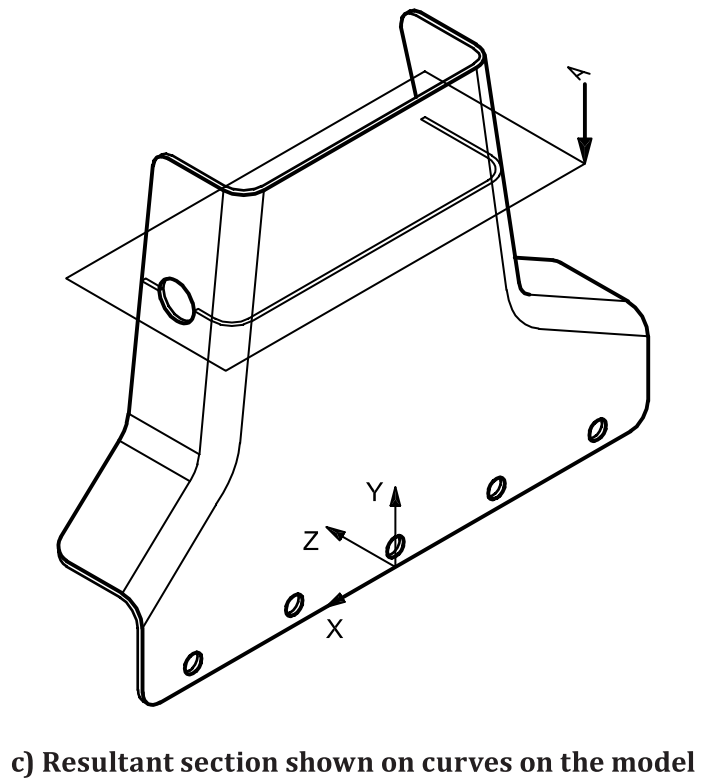
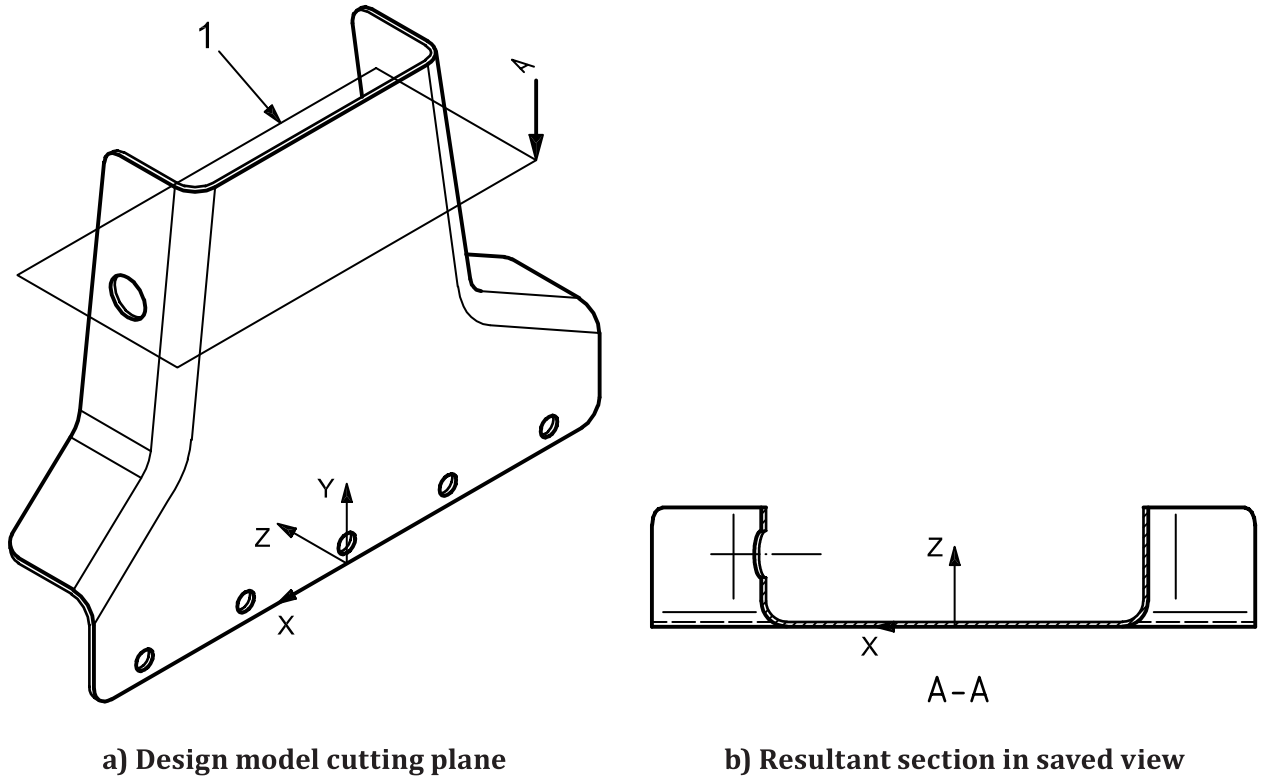

Key

1 identified cutting plane

Figure 4 — Design cutting model plane

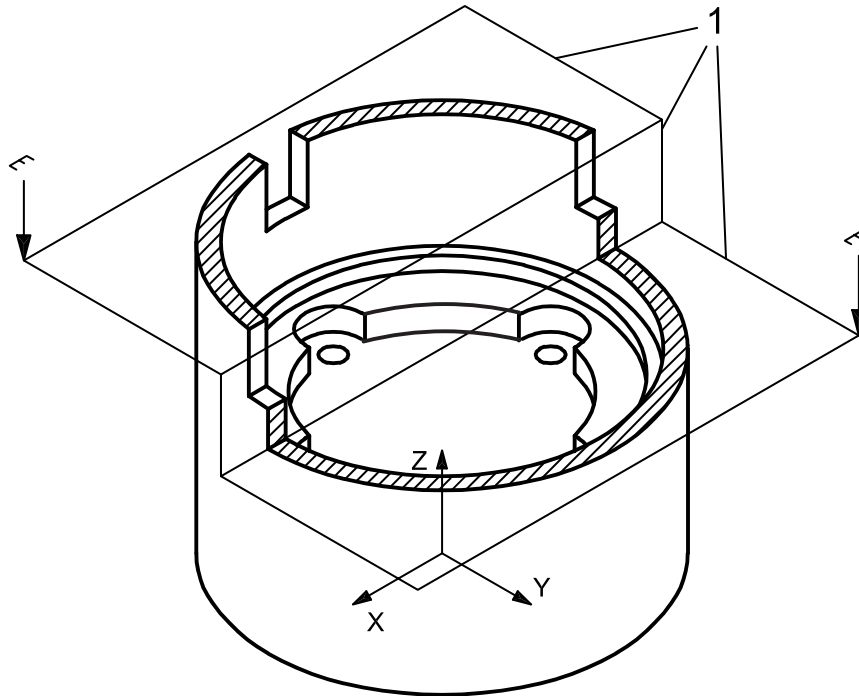

Key

1 multiple connected cutting planes

Figure 5 — Design model with offset section

6 Design model requirements

6.1 General

Design models represent a product in ideal geometric form at a specified dimensional condition, for example, minimum, maximum, or mean. The dimensional condition shall be specified as a general note.

6.2 Geometric scale, units and precision

Design models shall be modelled using a scale of 1:1.

The design model precision indicates the numeric accuracy required in the production of the workpiece in order for it to fulfil the design intent. The number of significant digits of the design model shall be specified in the data set. The number of decimal places required for the design cannot exceed the precision of the design model.

NOTE If the number of decimal places for a model is changed, this can cause dimensional values or tolerances to change because rounding is applied (see [9.2.2](#)).

6.3 Model completeness

The model shall contain geometry, attributes, and annotation as required to provide a complete definition of the part. The model shall be constructed so as to provide a complete definition of the workpiece (geometry, attributes, and annotation). In the event that this facility is not used,

- models not fully modelled shall be identified as such, e.g. a partially modelled symmetrical part,
- features that are not fully modelled shall be identified as such, e.g. threaded holes that are only shown as holes, and

- thin parts for which the thickness has not been modelled shall be indicated as shown in [Figure 6](#), using an arrow to indicate material direction in conjunction to the thickness indicator according to ISO 129-1. If the median plane of the geometry has been modelled opposing arrows can be used.

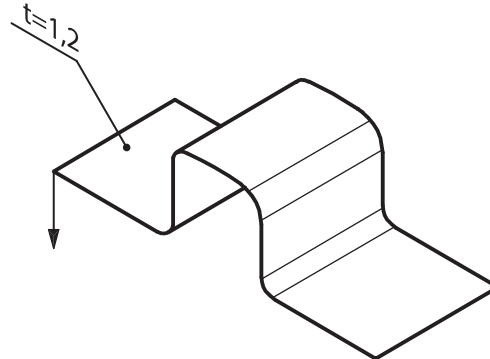

Figure 6 — Thickness indicator for non-modelled thin parts

6.4 Assembly model completeness

Assembly model completeness shall be in accordance with [6.3](#). Workpiece and sub-assembly models shown in the assembly model need only have sufficient detail shown to ensure correct identification, orientation, and placement. The assembly model can be shown in an exploded, partially assembled, or completely assembled state. Location and orientation of parts and assemblies can be shown by geometric definition, annotation, or a combination of both.

6.5 Installation model completeness

Installation model completeness shall be in accordance with [6.3](#) and [6.4](#). Workpiece and assembly models shown in the installation model need only be sufficiently detailed to provide installation and space requirements. The maximum envelope for parts and assemblies can be shown using supplemental geometry, annotation, or a combination of both. Location and orientation of parts and assemblies can be shown by geometric definition, annotation, or a combination of both.

7 Common requirements for product definition data

7.1 General

This clause establishes the common requirements for the application, display management, and query of product definition data. Specific requirements for particular types of product definition data are given in [Clauses 8](#) to [11](#).

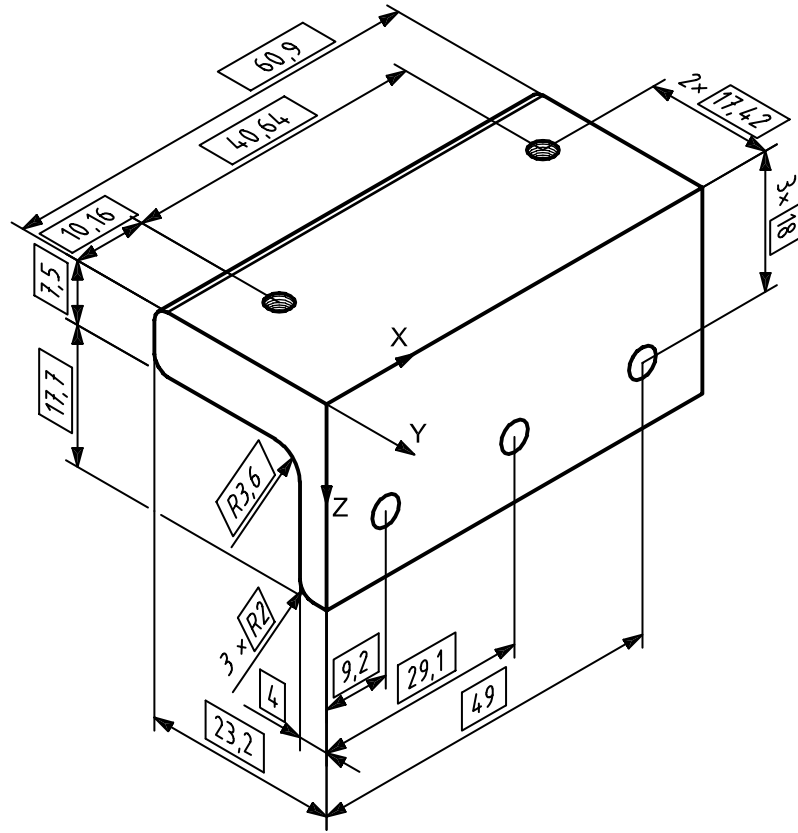

b) Model with one type of annotation displayed

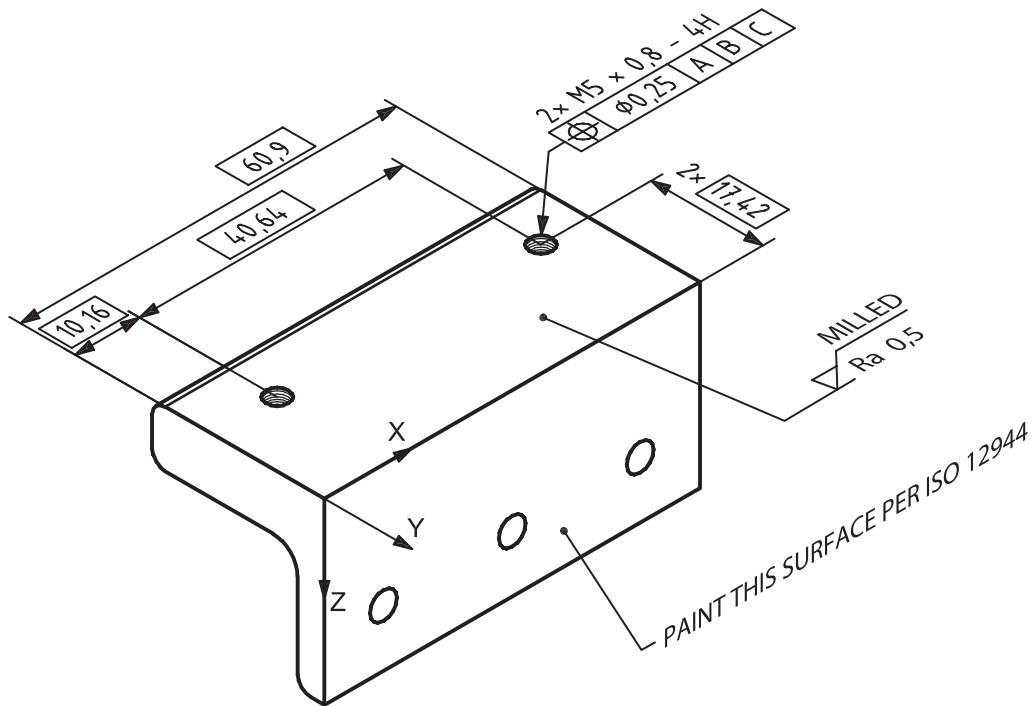

c) Model with selected annotation displayed

Figure 7 — Display management

7.2.2 Screen dump

A hard copy of any given visual display shall be available on demand. When a hard copy is intended to be used as an engineering drawing, it shall meet applicable drawing standards.

7.3 Model requirements

7.3.1 General

The following subclauses give requirements for annotation applied to a design model. These are general requirements, which apply to all types of annotation. Specific requirements for particular types of annotation are addressed in [Clauses 8](#) to [11](#). See [Figure 8](#) for a diagram showing the relationship between annotation and model geometry.

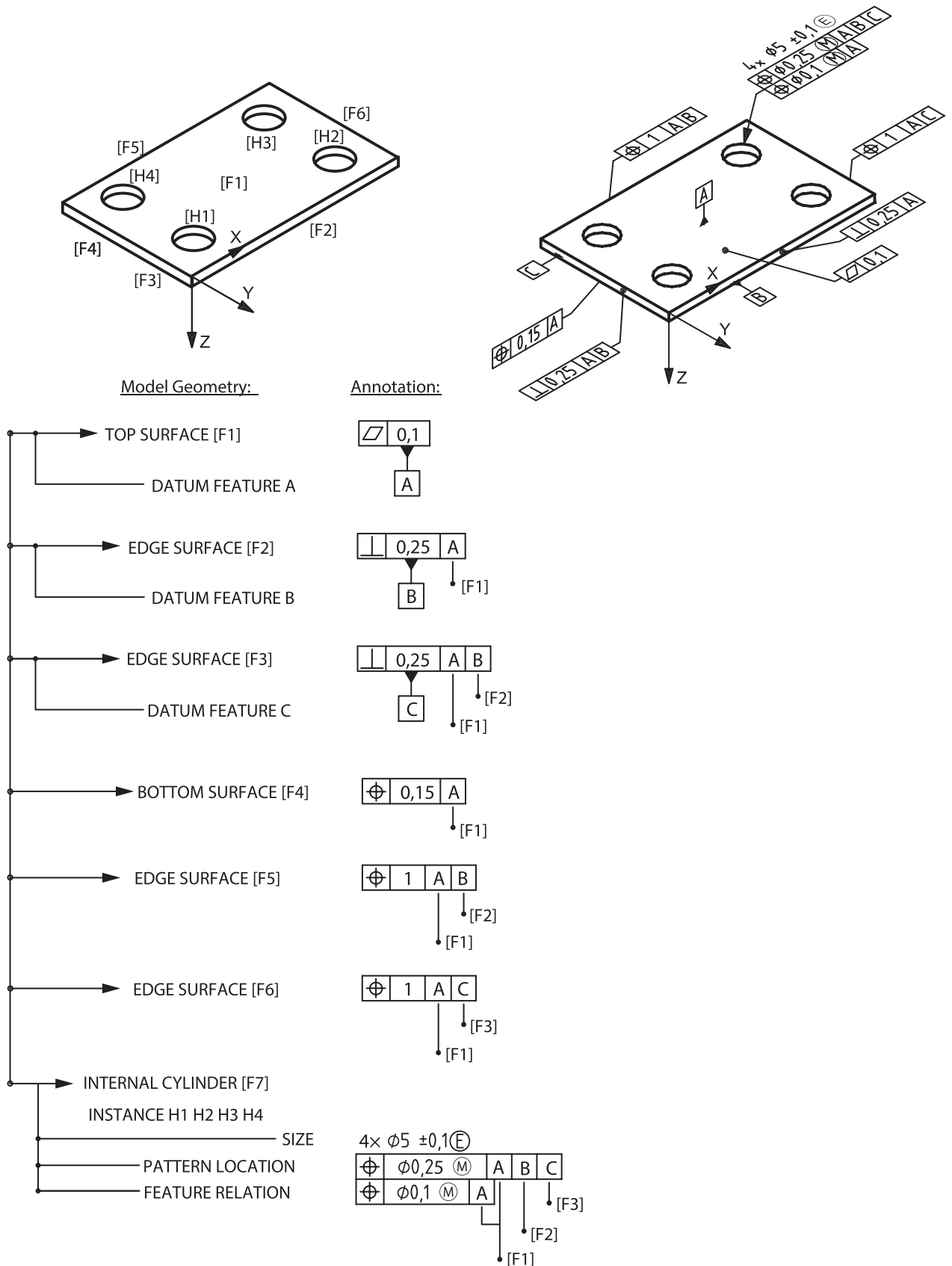

Figure 8 — Annotation and model geometry relationship

7.3.2 Associativity

The following are general provisions for defining an associative relationship between digital elements.

- Annotation can be associated to a model feature, a group of model features, or a portion of an applicable model feature. For an example of the associated entities for a dimension (see [Figure 9](#)).
- Annotation, model geometry, and supplemental geometry can be placed into associated groups to indicate their relationships.

EXAMPLE 1 Supplemental geometry used to define location, orientation, or further clarify the application of annotation to a model.

EXAMPLE 2 A model coordinate system for datum systems.

EXAMPLE 3 Other annotation. This could include qualifying notes and size limit indications.

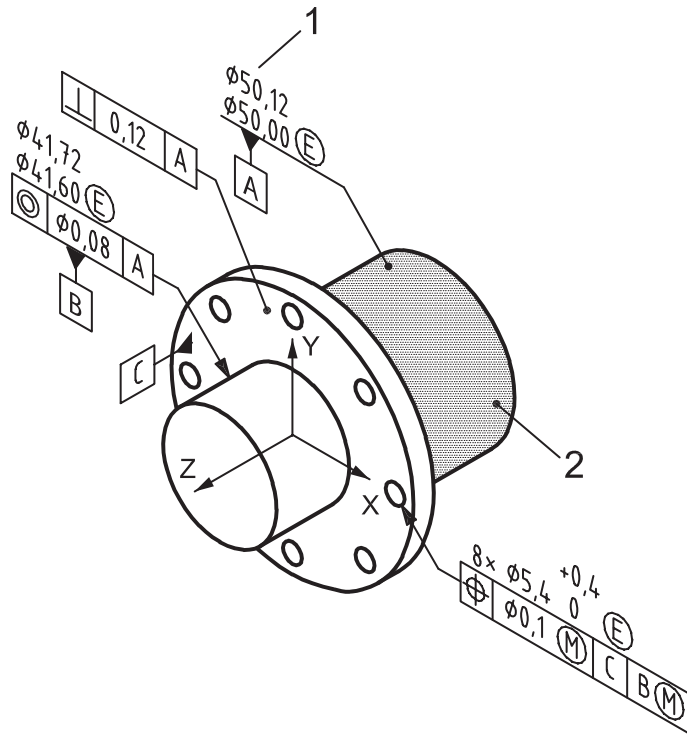

a) Size tolerance query

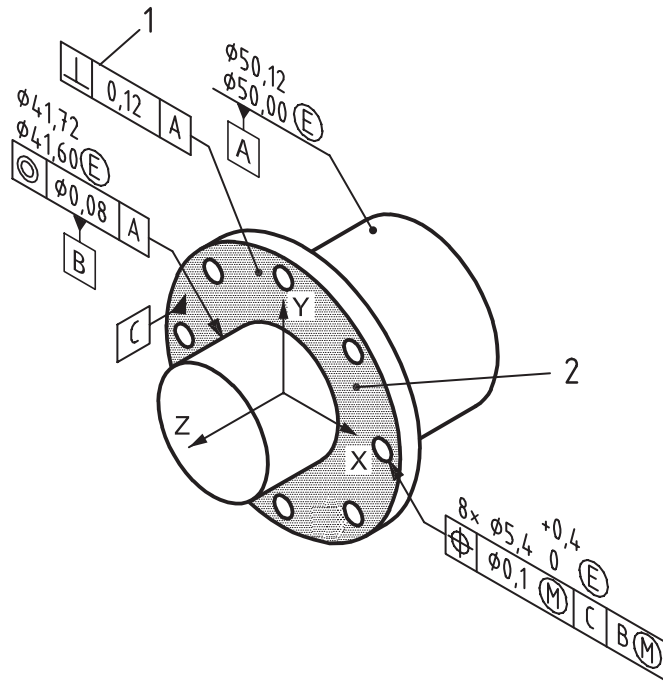

b) Geometric tolerance query

7.3.4 Annotation planes

The orientation of the annotation plane shall be maintained relative to the model geometry as the model is manipulated in 3D. For example, as the geometry is rotated, the text rotates correspondingly (see [Figure 11](#)). When a CAD system does not support maintenance of annotation plane orientation relative to the model, annotation planes shall not be used.

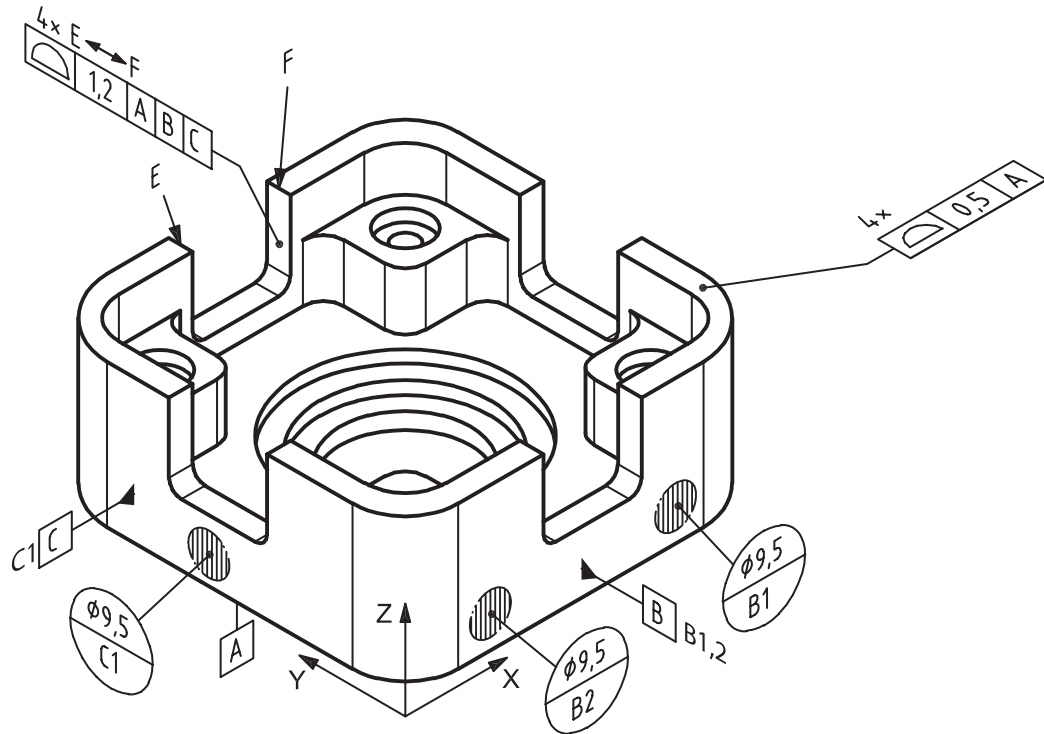

a) Initial attitude of model geometry and annotation

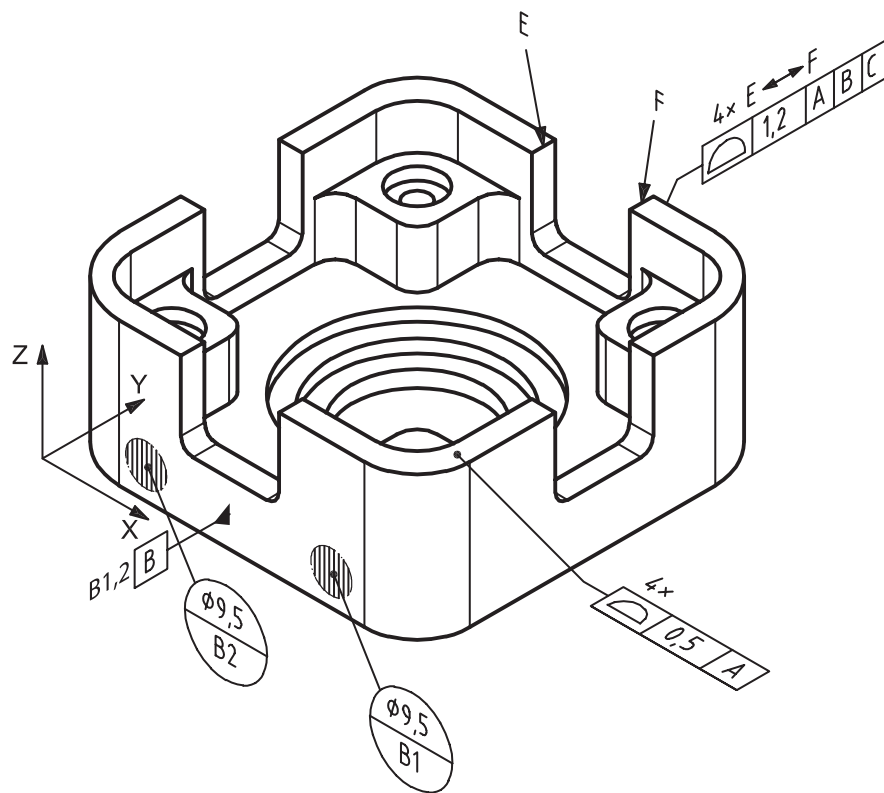

b) Rotated about the Z axis

Figure 11 — Annotation planes relative to model geometry

7.3.5 Leader lines

The termination of the leader line can be an arrow placed on a reference line using a leader line to point to the surface (see [Figure 56](#)). When an indicated element is a surface, the leader line shall terminate with a dot within the bounds of the surface. Leader lines directed to represented line elements shall terminate with an arrowhead. Leader lines can terminate on the rim or edge of a feature of size when doing so provides a clearer understanding of the intention of the annotation. A continuous leader line shall be used to indicate all datum targets in a design model. Leader lines shall be directed to an associated entity.

7.3.6 Direction-dependent tolerances

When a direction-dependent tolerance (e.g. straightness) is applied to a design model, the direction shall be explicitly defined as follows.

- Supplemental geometry is added to the model to show the direction of application. The model geometry to which the tolerance applies shall be the associated geometry for the annotation [see [Figures 41, 47, and 56](#) and [5.2.3 a\)](#)].
- Direction-dependent tolerances may use a model coordinate system vector to define the direction of application. The model coordinate system vector, associated entity, and tolerance shall be organized as an associated group (see [Figures 42, 48, and 57](#)).
- As indicated in ISO 1101, the use of a represented line element or model coordinate system vector is a valid means of indicating the direction of application of a tolerance. However, when this presentation is used without additional supporting information, it is functionally equivalent to the presentation historically used on drawings. The use of the intersection plane indicators or orientation plane indicators on the tolerance frames, per ISO 1101, can be used to include more information in the presentation of the specification regarding its definition. Such additional information may alternatively be embedded in the 3D digital model but not necessarily depicted with the presentation of the specification. See [Figure 43](#) for an example of an intersection plane indicator.
- When the lay for a surface texture indication is direction-dependent, the direction of the lay can be indicated using either supplemental geometry or association to a model coordinate system vector (see [Figure 56](#)).

7.3.7 Indicating limited application of a tolerance

Limited length, area, and location indicators may consist of, but are not limited to, supplemental geometry and associative annotation. When supplemental geometry is used, it shall be located on the model geometry (see [Figure 29](#)).

7.3.8 Query types

The model shall contain information sufficient to satisfy the following query types.

- a) Model values
- b) Relationship between model geometry and annotation in either direction, including the following:
 - Graphic display of associated entities: the associated entities for a piece of annotation shall be highlighted, or otherwise distinguished from other entities on the display, on demand (see [Figures 9](#) and [36](#)).
 - Graphic display of associated annotation: all annotations associated with selected geometry or model features shall be highlighted, or otherwise distinguished from other entities, on demand [see [Figure 12 b\)](#) and [Figure 40 b\)](#)].
- c) Digital element identifiers (see [Figure 13](#))

- d) Model geometry and model features
 - Model features shall be identifiable by selecting a geometric element of the model feature.
 - All geometric elements in an associated group of model features shall be identifiable by selecting any geometric element within the group.
 - All model features in a group of model features shall be identifiable by selecting one of the model features.
- e) Tolerance frames, datum target indicators, and datum indicators
 - Upon selection of a tolerance frame, the datum indicators and datum target indicators that correspond to the datum references shall be highlighted or otherwise distinguished from other entities on the display (see [Figure 14](#)).
 - Upon selection of a datum target indicator, all datum target indicators sharing the same letter shall be highlighted or otherwise distinguished from other entities on the display (see [Figure 15](#)).
 - Upon selection of a datum indicator, the datum target indicators which have the same datum letter shall be highlighted or otherwise distinguished from other entities on the display (see [Figure 16](#)).
- f) Supplemental geometry used in the definition of annotations, appropriately highlighted or otherwise distinguished from other entities on the display.
- g) Identification of all elements of an associated group, appropriately highlighted or otherwise distinguished from other entities on the display, through the selection of any one element.

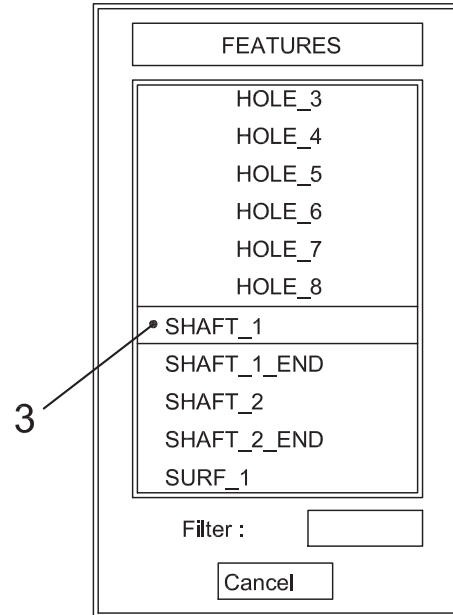
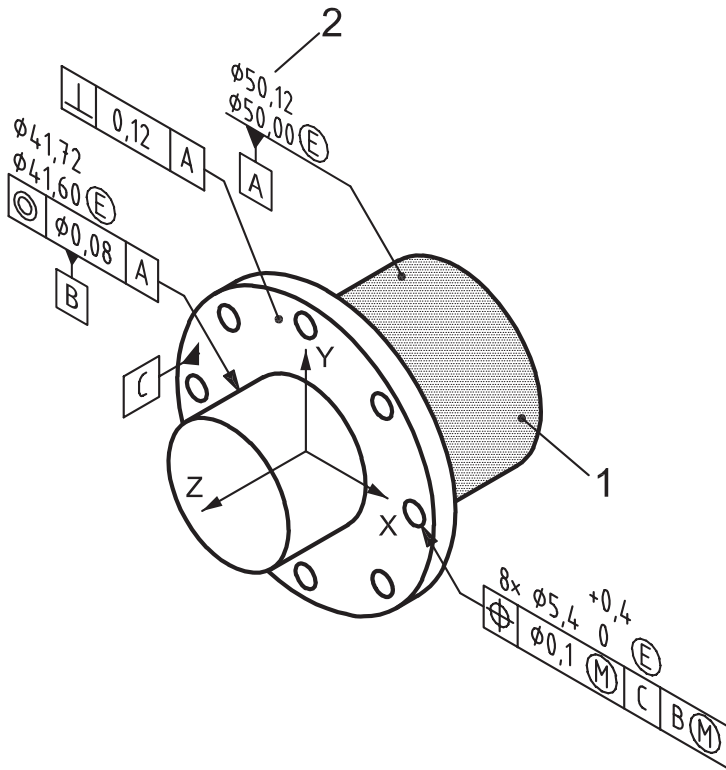

a) Individual feature

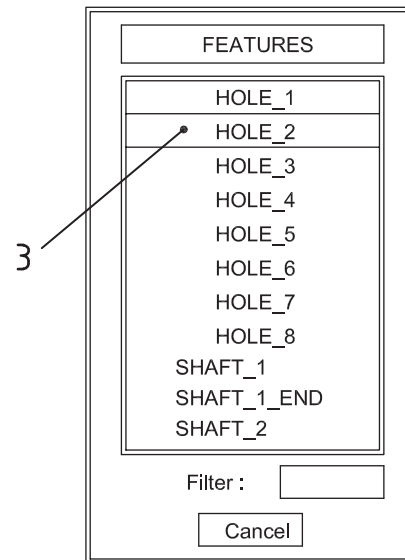
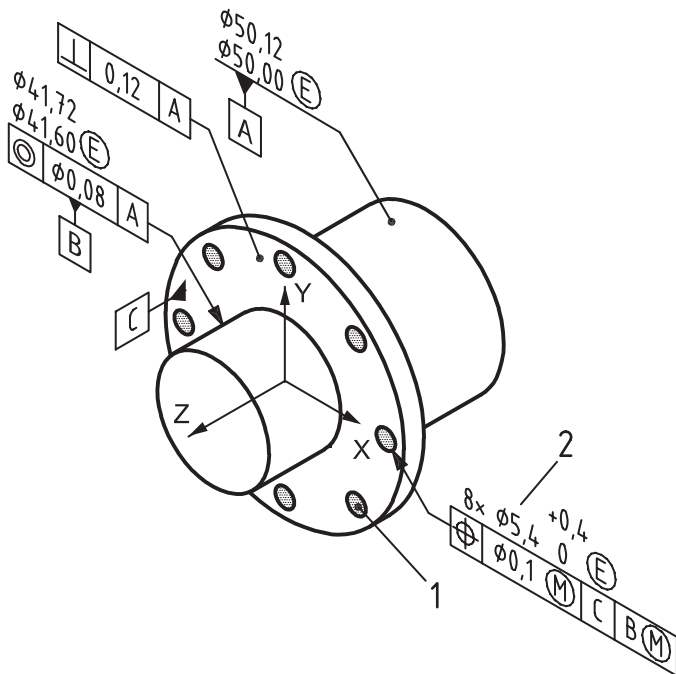

b) One feature of a pattern

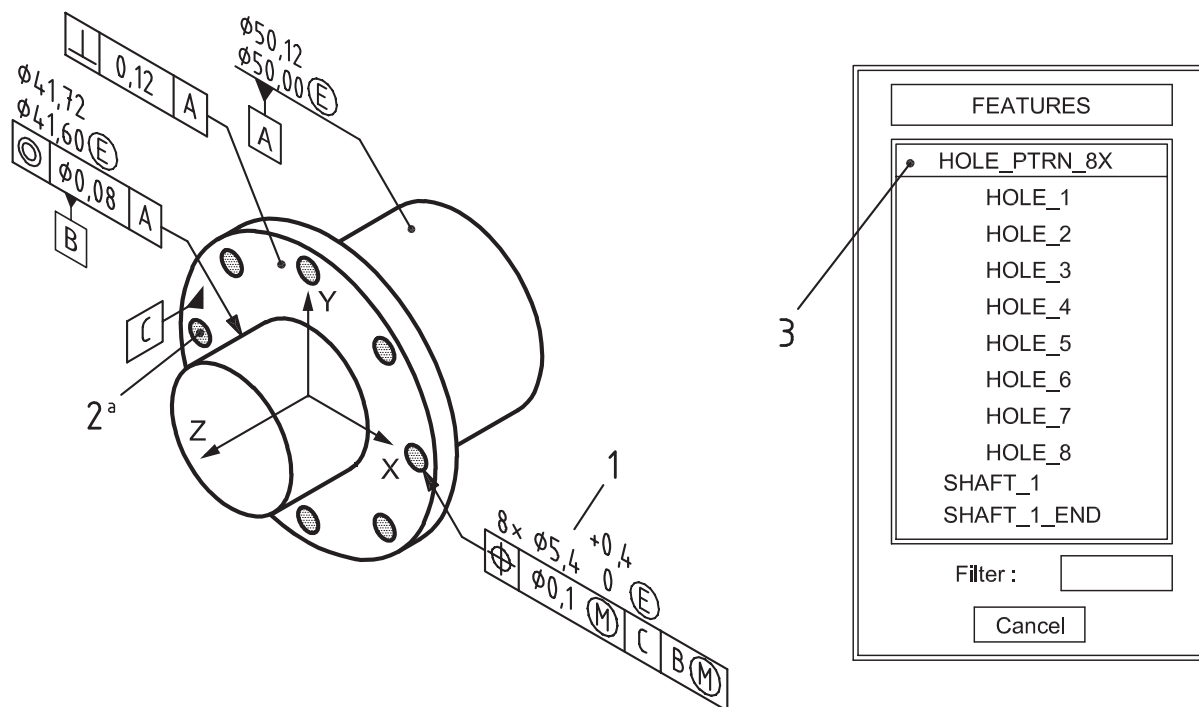

c) Pattern of features

Key

- 1 query
- 2 visual response
- 3 attribute response
- a All eight associative features.

Figure 12 — Graphic display of associated annotation

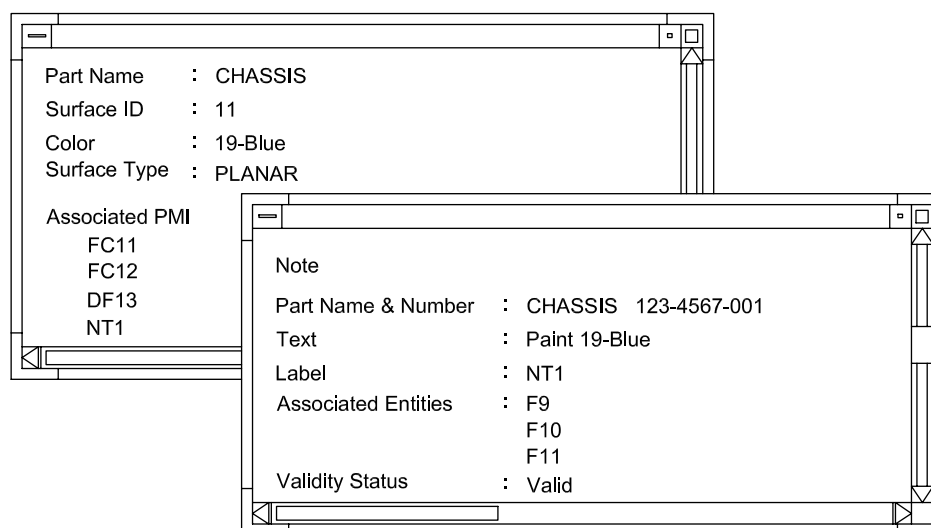
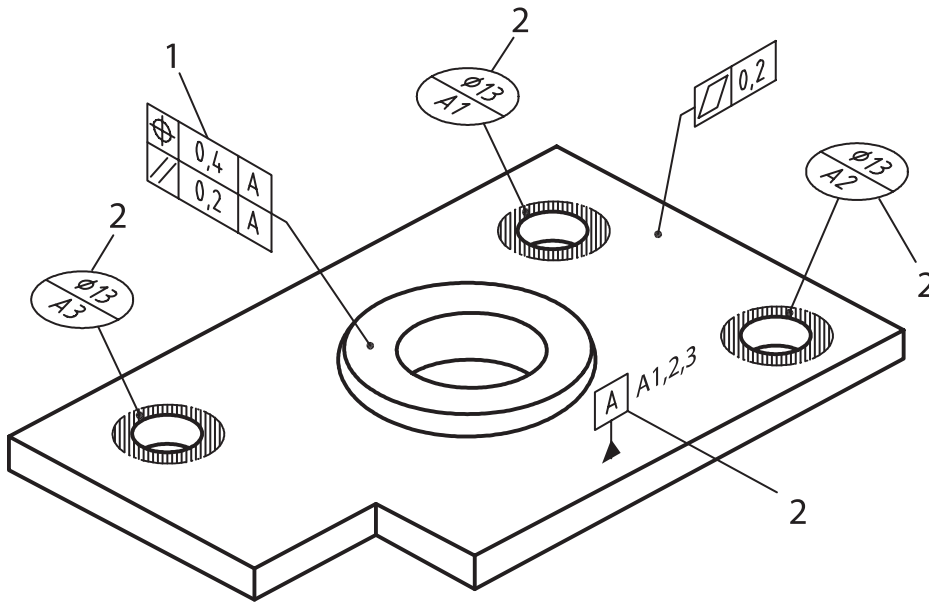

Figure 13 — Listing of digital elements identifiers



Key

- 1 query
- 2 visual response

Figure 14 — Queries of datum indicators and datum target indicators

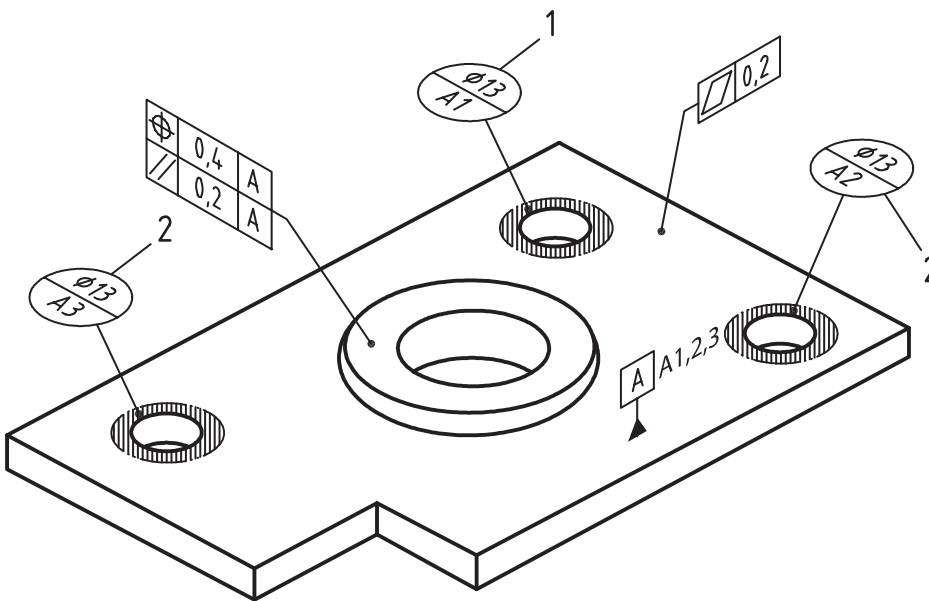

Key

- 1 query
- 2 visual response

Figure 15 — Queries for datum targets

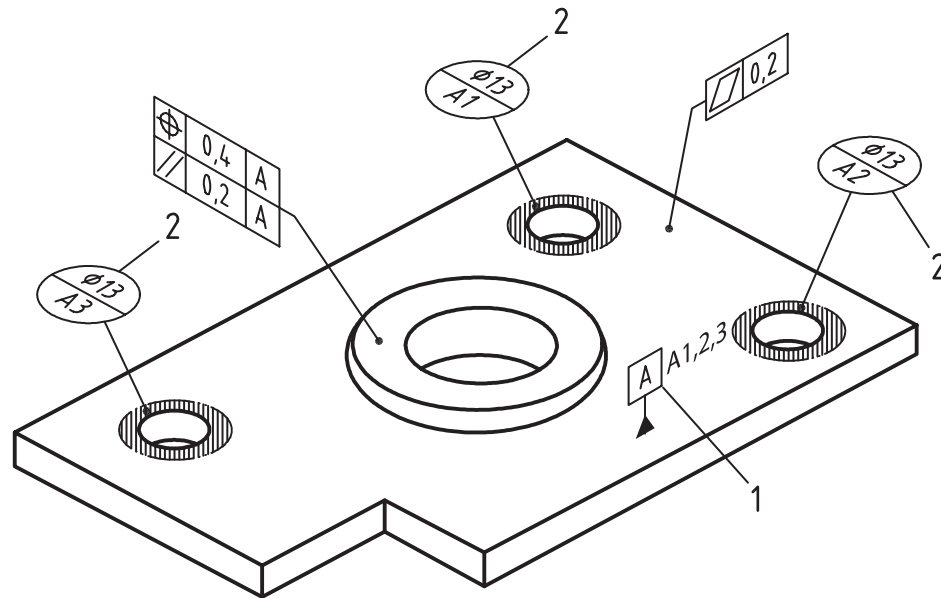
**Key**

- 1 query
- 2 visual response

Figure 16 — Queries for datum indicators

7.4 Drawing requirements

7.4.1 General

See ISO 128-30, ISO 128-34, ISO 128-40, and ISO 128-44 for sections and views. The following subclauses describe exceptions or additions for views on drawings. The following subclauses also describe general requirements for axonometric views on fully or partially defined drawings. Specific requirements for particular types of annotation are addressed in [Clauses 8](#) to [11](#). The relationship between a model and a drawing are illustrated in [Figures 17](#) and [18](#).

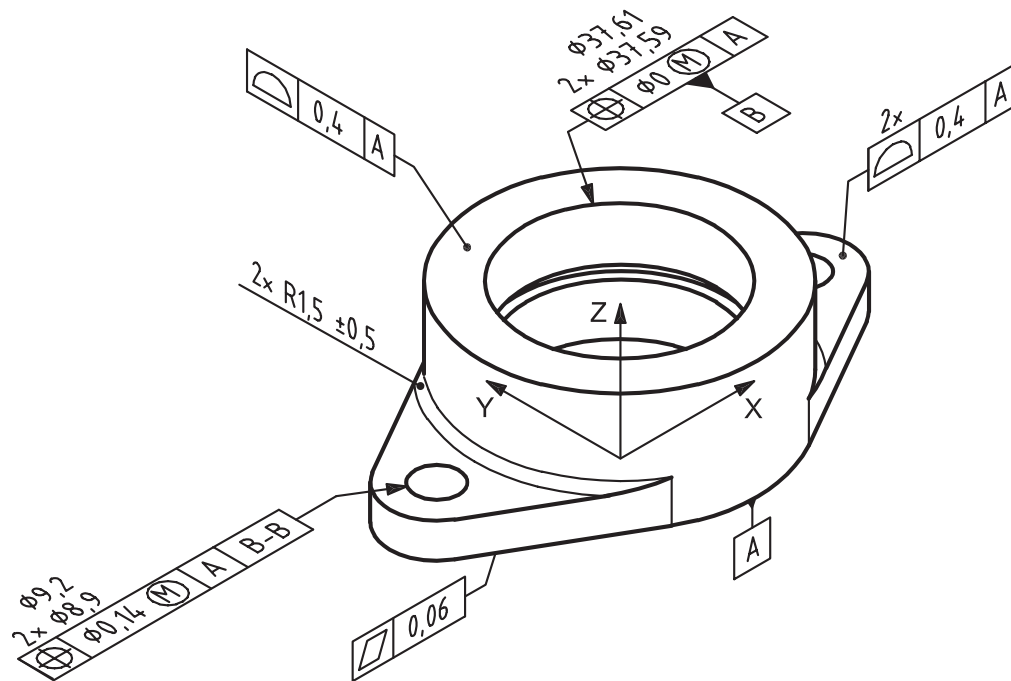

Model 123-4567

Figure 17 — Annotated model

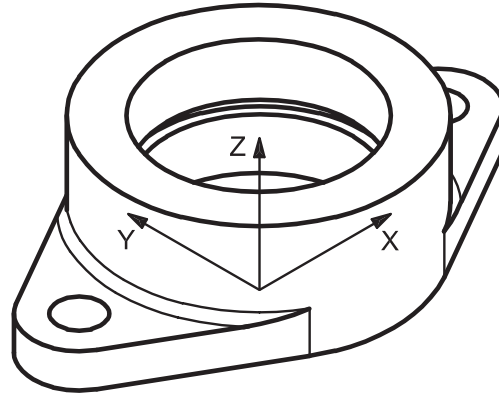

Design model 123-4567

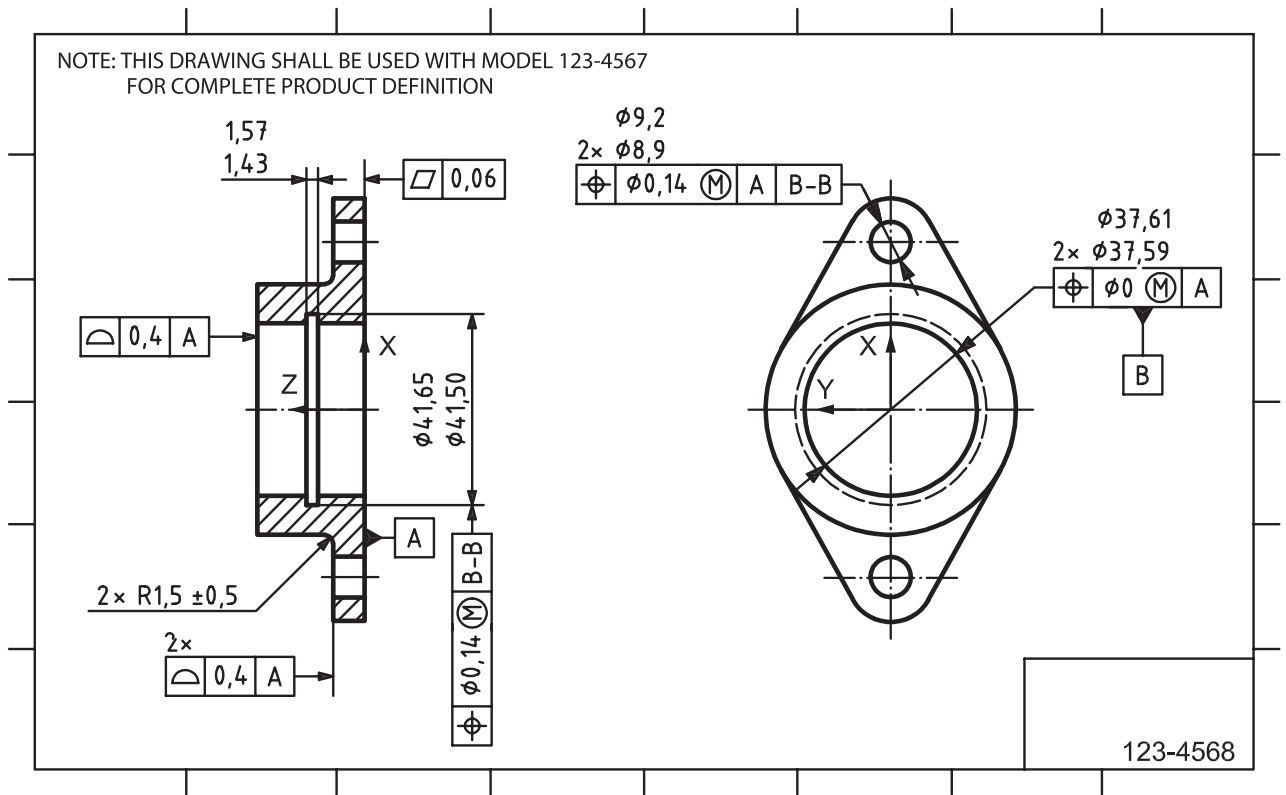

Engineering drawing 123-4568

Figure 18 — Design model and drawing

7.4.2 Orthographic views

When orthographic views are used, the model coordinate system can be used to indicate view orientation.

7.4.3 Axonometric views

A model coordinate system shall be included in each axonometric view to indicate orientation of the view [see [Figure 19 a](#)].

Section views may be created from axonometric views. A section view can be orthographic or axonometric.

- A representation of a cutting plane shall be used to indicate the location and viewing direction of a section. The edges of the cutting plane shall be continuous or long-dashed dotted lines. A visible viewing arrow or arrows shall be included to show the direction in which the section is viewed (see [Figure 19](#)). The cutting plane and the cuts and sections shall be indicated according to ISO 128-40 and ISO 128-44.
- The result of the section cut can be shown either by removing material from the part [see [Figures 19 a](#) and [19 b](#)] or by display of the curves overlaid on the view that result from intersecting the cutting plane with the part [see [Figure 19 c](#)].
- Sections taken from axonometric views can be presented in the same orientation as the parent view or rotated to present the section in the viewing plane of the drawing.
- The use of a stepped or offset cutting line is supported in axonometric views. The resulting section cut geometry can be shown in its true position on the design model or drawn as if the offsets were in one plane.
- The use of a cutting plane line containing angular changes is supported in axonometric views. The resulting section can show all features in their true position on the design model or be drawn as if the bent cutting plane and features were rotated into a plane perpendicular to the line of sight of the sectional view.
- Features can be shown in their actual position, without foreshortening or alignment, when the section is made from an axonometric view.
- Features can be shown in their actual location when shown in a section view cut from an axonometric view.

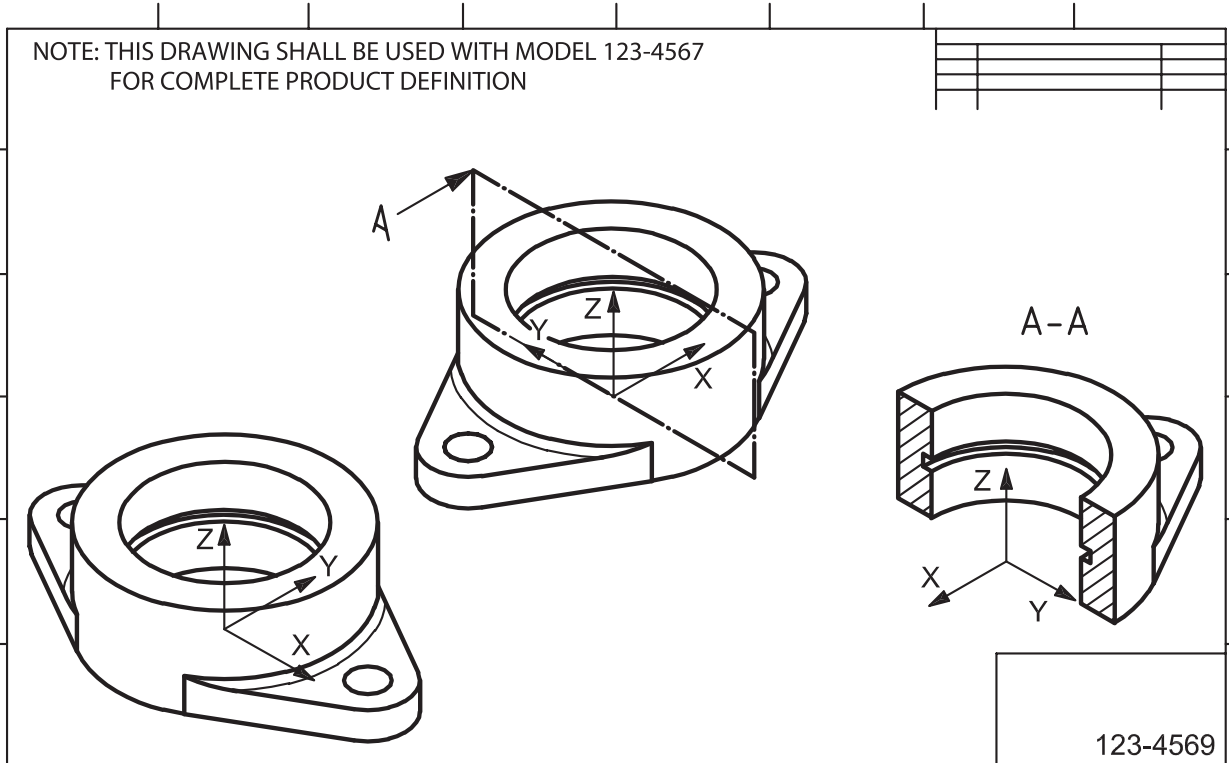

a) Drawing with axonometric view

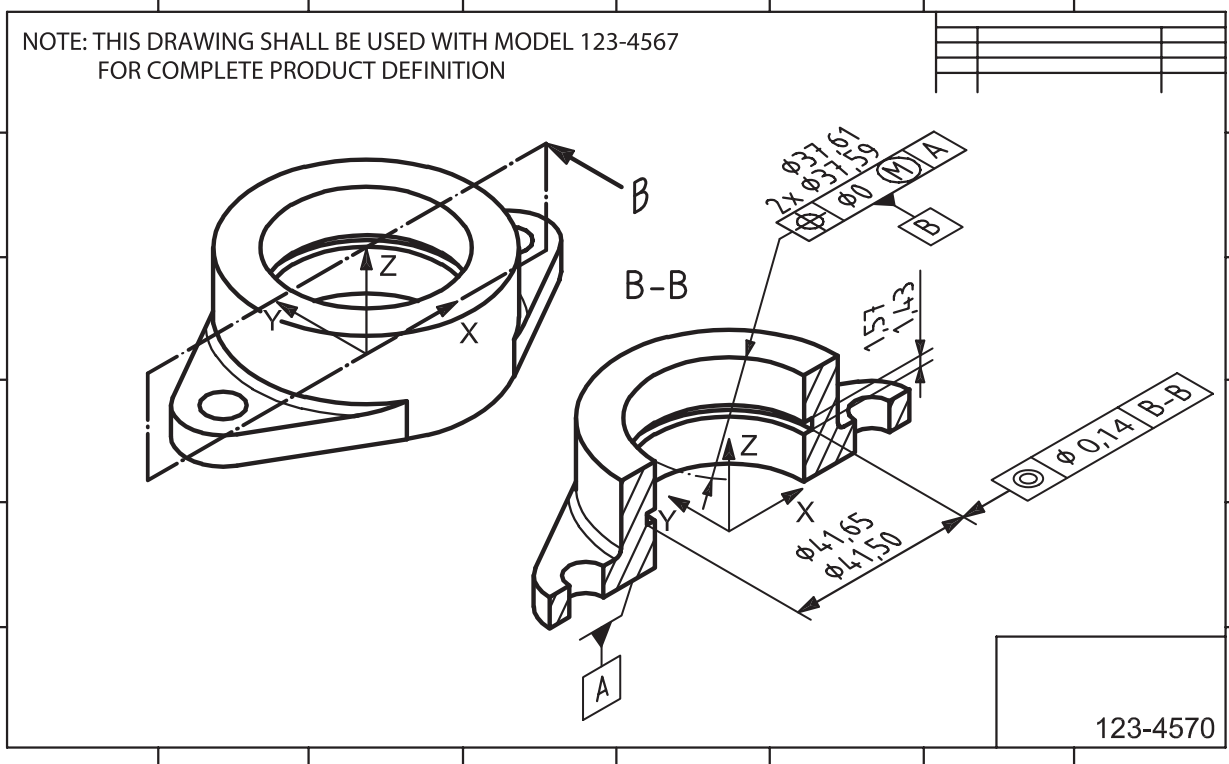

b) Axonometric section view

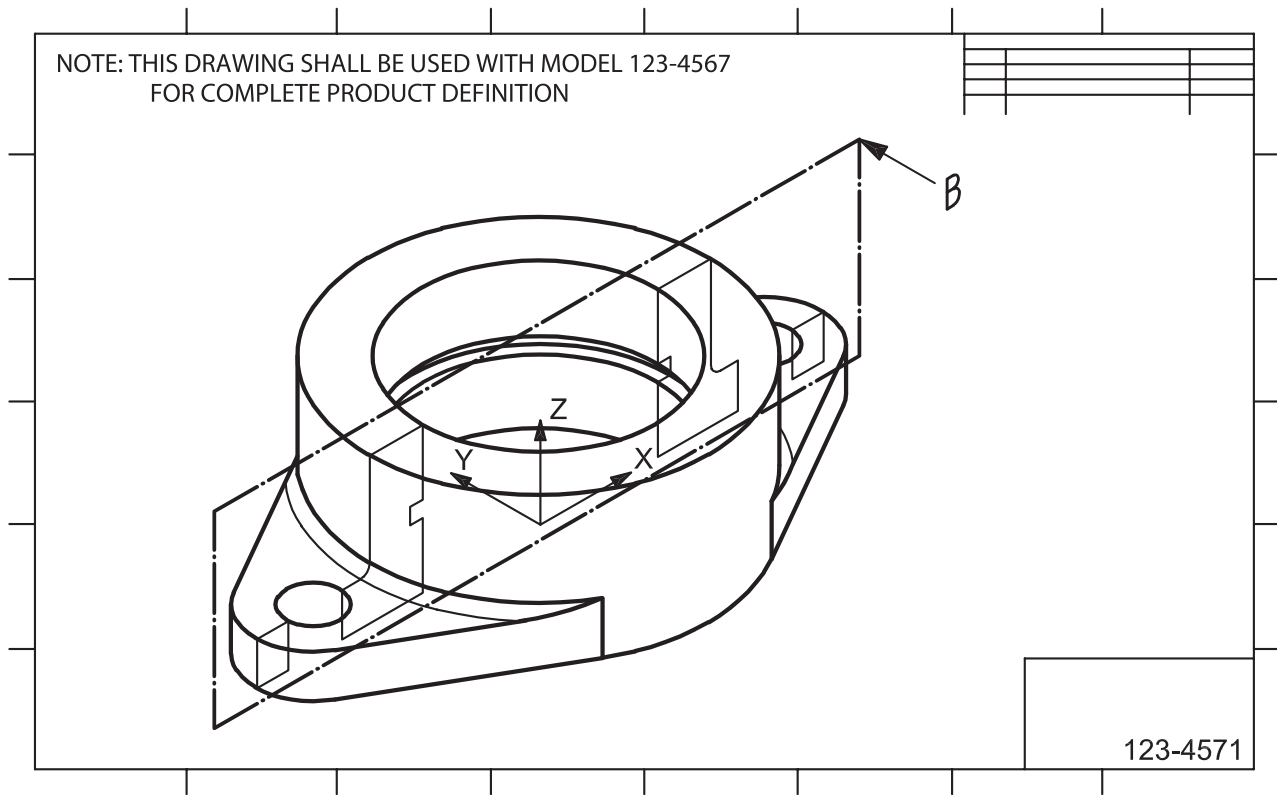

c) Section curves shown in an axonometric view

Figure 19 — Axonometric views

8 Notes and special notations

8.1 Common requirements

There are no common requirements for notes and special notations.

8.2 Model requirements

When general notes, flagnotes, and special notations are placed in a model, they shall be placed on a single annotation plane that does not rotate with the model. This annotation plane shall be available for display with the annotated model.

General notes do not require associativity. General notes can include general tolerance(s) for the entire model. Local notes shall be associative to the applicable digital elements in the model. When a flagnote is placed in a model, the following shall apply:

- the flagnote symbol and text shall be placed on the notes area annotation plane;
- the flagnote symbol and text shall be associative to the digital elements to which it applies;
- the flagnote symbol shall be shown adjacent to the applicable digital elements in the model;
- the flagnote symbol shown adjacent to the digital elements in the model shall rotate with the model.

When special notations are placed in a model, the following shall apply:

- when the special notations are applicable to the entire model, the notation shall be placed on the notes area annotation plane;

- when the special notations are applicable only to a portion of a model, the special notations symbol and its associated text shall be placed on the notes area annotation plane in accordance with [8.2](#). The special notations symbol shall be shown adjacent to the applicable digital elements in the model. The special notation symbol shall be associative to the digital elements to which it applies.

8.3 Drawing requirements

In axonometric views, leader lines shall be used to associate each local note to its related model feature.

9 Model values and dimensions

9.1 General

This clause establishes the requirements for model value query, resolved theoretically exact and radial dimensions, linear and angular distance, size, and limits of dimensions in a data set. It also contains the common requirements for associativity and dimensions on a model or drawing.

9.2 Common requirements

9.2.1 Model value queries

The following model value queries shall always be conducted in relation to the absolute or a user-defined model coordinate system of the design model:

- determination of location and orientation of surfaces;
- determination of distance or angle between two surfaces;
- determination of position (location and orientation) of features of size (as per ISO 17450-1);
- determination of feature relation (hole-to-hole spacing and orientation) dimensions within a pattern of features of size.

Direct query of the model surface or model feature of size is usually conducted for

- determining the shape (curvature) of surfaces and
- determining the size value for a feature of size or a pattern of features of size.

9.2.2 Resolved dimensions

Dimensions displayed on a model are resolved dimensions. For examples of resolving model values to displayed dimensions, see [Table 1](#). The requirements for resolved dimensions follow.

- a) To obtain a resolved dimension, a model value shall be rounded to the number of decimal places required for the design.
- b) All resolved dimensions shall be absolute values in accordance with ISO 129-1 and ISO 1101.
- c) Rounding shall be in accordance with ISO 80000-1.
- d) Resolved dimension preservation and association: a direct and permanent association to the originating model value shall be established and maintained for every resolved dimension.
- e) Utilization of model or resolved dimensions: the use of model values or resolved dimensions for analyses and other processes shall be defined in appropriate documentation.

9.2.3 Plus and minus tolerances

One or more general notes defining plus and minus tolerances can be specified, such as a general tolerance.

Table 1 — Resolved dimension examples

(Applicable International Standard)	ISO 16792		Application example
	Model value ^a	Resolved dimension ^a	
Linear theoretically exact dimension (linear TED) ^b (ISO 1101)	88,410 000 0...	88,4	
Angular theoretically exact dimension (angular TED) (ISO 1101)	28,591 827 3...	28,6	
Size ^c (ISO 14405-1)	7,000 000 0...	7,0	
Size (ISO 286)	45,700 000	45,7	45,7 h7
Linear distance	19,666 666 6...	19,67	
Radial distance (ISO 14405-2)	3,150 000 0...	3,2	
Angular dimension	28,591 827 3...	28,6	
Unilateral limit ^b	12,000 000 0...	12	12 min.
Auxiliary dimension ^b (ISO 129-1)	21,601 804 3...	21,6	

^a The values shown are examples. Actual values reflect the defined precision of the model and the rounding requirements of each particular application.

^b Linear, radial, angular, diametrical, or spherical diameter.

^c Linear, diametrical, or spherical diameter.

9.3 Model requirements

9.3.1 General

Requirements for attaching and displaying theoretically exact dimensions, size values, and plus and minus tolerances on a model are defined in the following subclauses.

9.3.2 Theoretically exact and nominal dimensions

Queried model values for features fully constrained by geometrical tolerances shall be interpreted as theoretically exact dimensions, per ISO 1101. In all other circumstances, queried model values not

defined by a specific tolerance, or identified as an auxiliary [see 5.1.1 a)], shall be interpreted as a nominal dimension, i.e. covered by a general tolerance.

NOTE ISO 2768-1 does not apply to nominal dimensions obtained by querying values from a model.

- Querying of the model for the profile, location, and orientation of a feature shall occur within the appropriate model coordinate system (see 9.2 and 10.3.1).
- The display of theoretically exact dimensions can be necessary in defining some model relationships. This is applicable to an inclined datum feature and features that can appear to be 90° but for which the actual model angle is other than this. Displayed theoretically exact dimensions shall be enclosed in a frame in accordance with ISO 1101.
- Theoretically exact dimensions should be placed in annotation planes that are parallel with one of the planes of the absolute or a user-defined model coordinate system. The 6,35 dimensions in Figure 20 show an exception because the annotation plane is defined based on the geometry.
- Theoretically exact dimensions defining surface curvature or extent, such as fillets, rounds, or chamfers, shall be directed to the model feature surface by a leader line (see Figure 20).
- Theoretically exact dimensions defining linear distance or angular relation are shown using dimension and extension lines (see Figure 20).

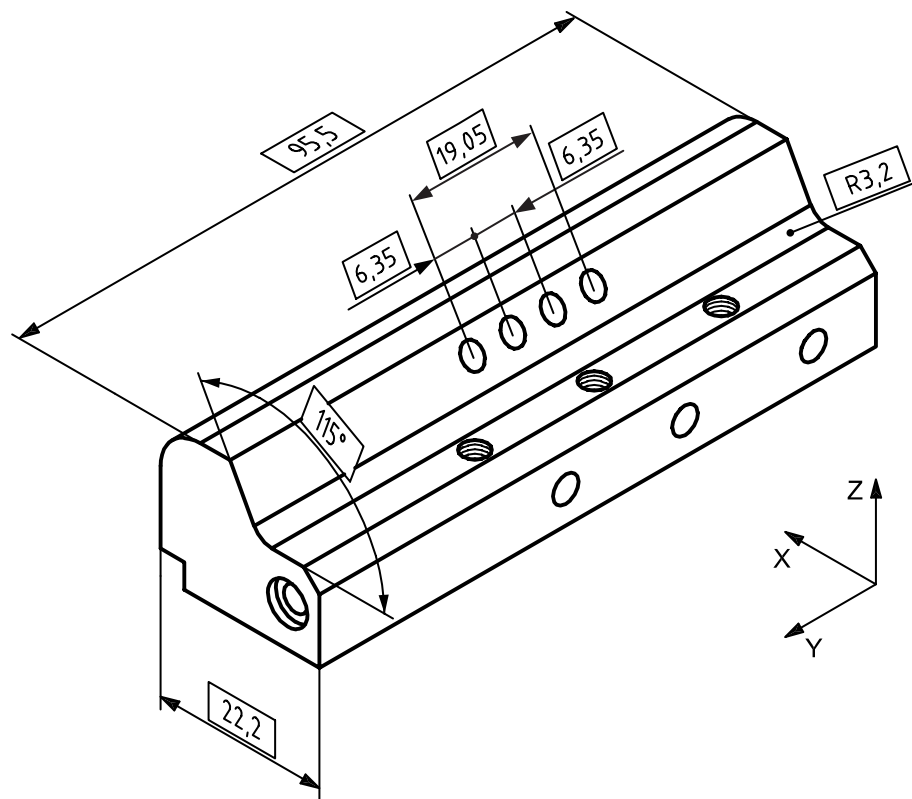

Figure 20 — Placement and attachment for theoretically exact dimensions

9.3.3 Size values

A size value shall not conflict with the queried model value for the same feature when the model value is rounded to the same number of decimal places. This agreement shall meet one of the following requirements, depending on the tolerance expression used.

For bilateral or unilateral tolerances, the displayed size value shall equal the resolved model value.

For size values, the placement and attachment methods for size values are as follows.

- Spherical surface: the size value, dimension, and extension lines shall be placed on an annotation plane containing the model feature centre-point;
- Cylindrical surface: the size value, dimension, and extension lines shall be placed on an annotation plane perpendicular to the model feature axis or containing the model feature axis;
- Set of two opposed parallel surfaces (a width): the size value, dimension, and extension lines shall be placed on an annotation plane perpendicular to, or containing, the model feature centre plane (the extension lines shall clearly indicate the surfaces comprising the width, see [Figure 21](#) for examples).

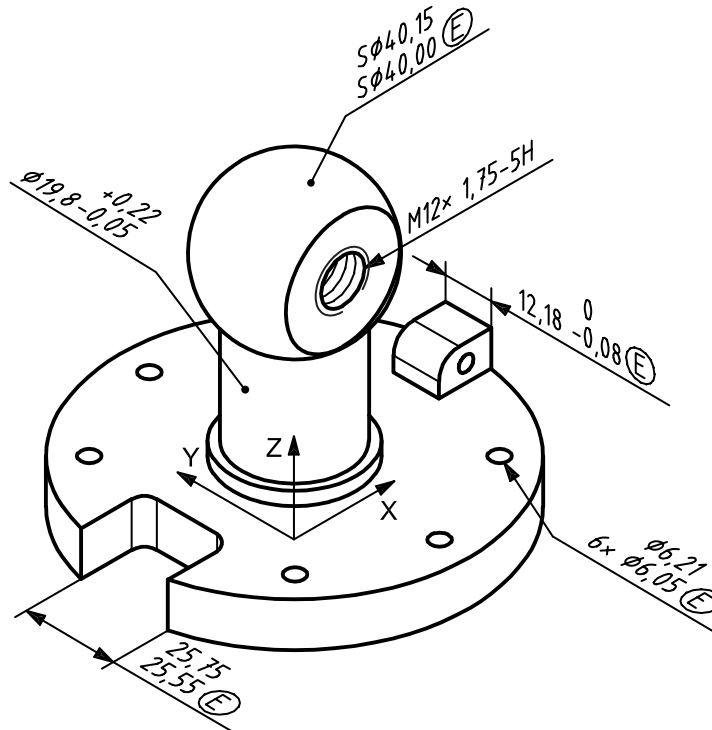

Figure 21 — Placement and attachment for linear dimensions

9.3.4 Coded size tolerances

Size tolerances can be specified using the ISO system of coded size tolerances as specified in ISO 286. When this type of tolerance specification is used, ISO 286 shall be cited in the general notes on the model.

9.3.5 General applications of plus and minus tolerances

Guidance with regard to the application of plus and minus tolerances to linear, angular, and radial dimensions is given in [Table 2](#).

The attachment method believed to be most commonly used is shown.

9.3.6 Chamfers

Attachment for 90° surface intersections with an equally disposed chamfer is indicated in [Table 2](#). Oblique surface intersections, unequally disposed extents, or chamfers defined using a linear and angular dimension require the use of dimension and extension lines [see [Figures 22 d](#)) and [22 e](#)]]. The value shall be located and oriented in a manner that is clear.

Table 2 — Examples of plus and minus tolerance applications

General application	Attachment technique			Figure
	Dimension indication	Directed leader line	Extension lines	
Fillets, round, chamfers		X	X	22
Reliefs, step surface			X	23
Countersinks	X			24 a)
Oblique surfaces			X	24 b)
Entry depth	X			25 a)
Counterbore	X			25 b)
Remaining thickness			X	25 c)
Notches, flats, and pin height			X	26

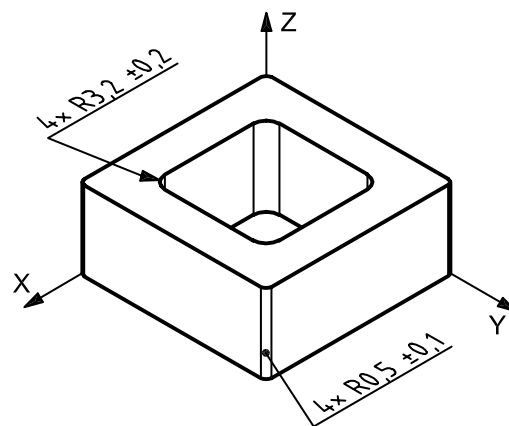

a) Fillets and rounds

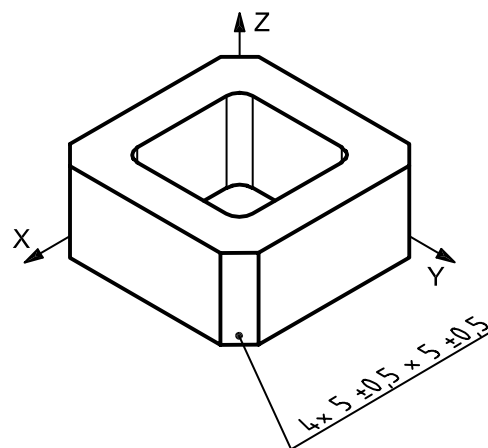

b) Chamfer — Equal offsets

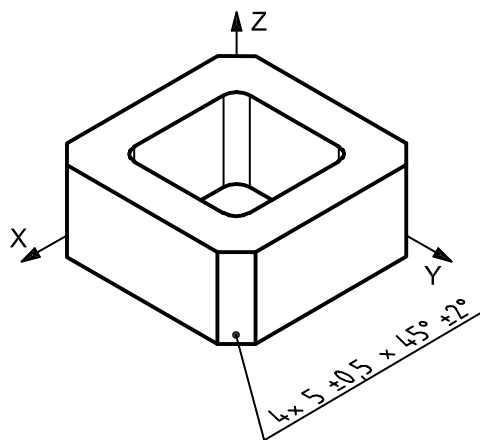

c) Chamfer — Offset and 45° angle

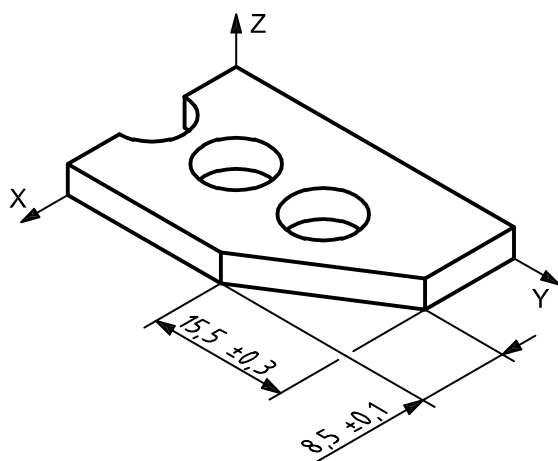

d) Chamfer — Unequal offsets

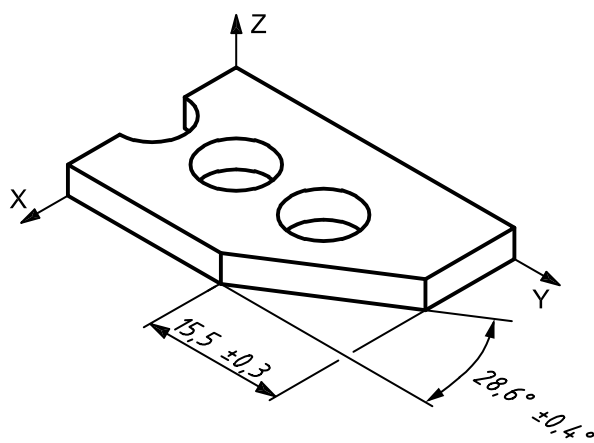

e) Chamfer — Offset and angle

Figure 22 — Attachment techniques — Fillets, rounds, and chamfers

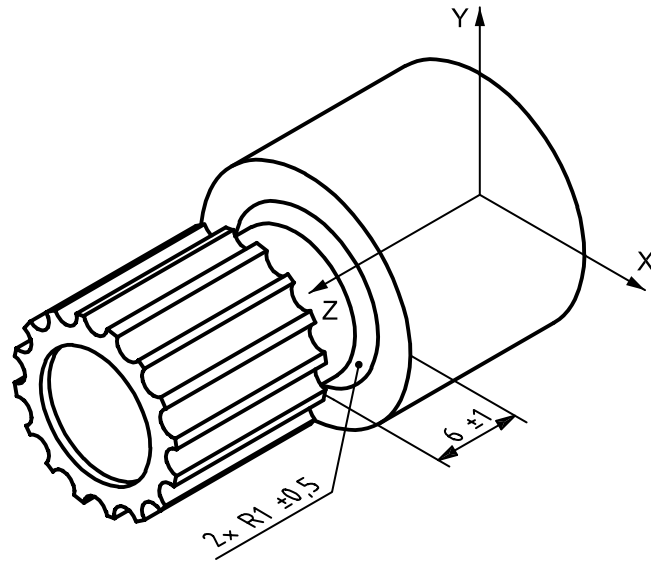

a) Relief

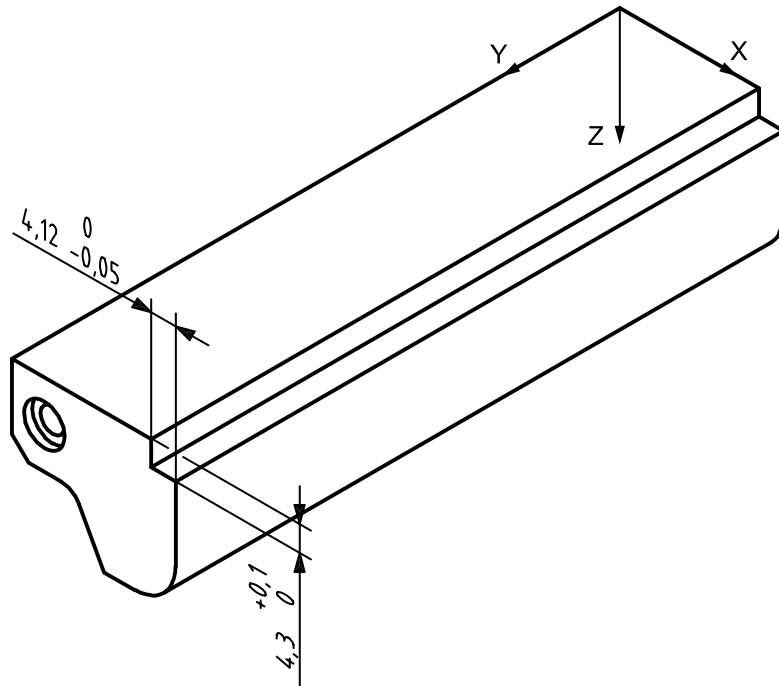

b) Step surfaces

Figure 23 — Attachment techniques — Reliefs and step surfaces

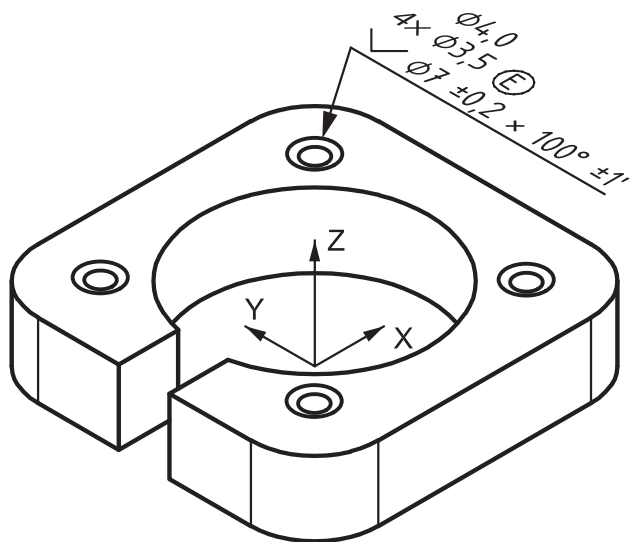

a) Countersinks

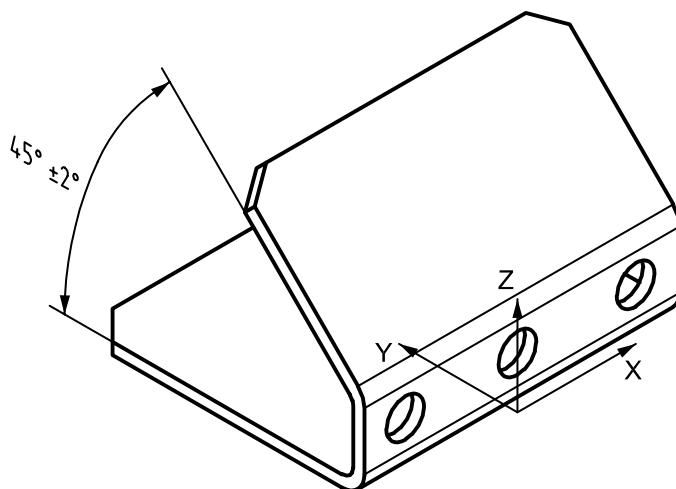

b) Oblique surfaces

Figure 24 — Attachment techniques — Countersinks and oblique surfaces

9.3.7 Depth specification

When a feature depth is governed by a remaining thickness tolerance, the feature tolerance and the remaining thickness requirement should be an associated group [see [Figure 25 c](#)].

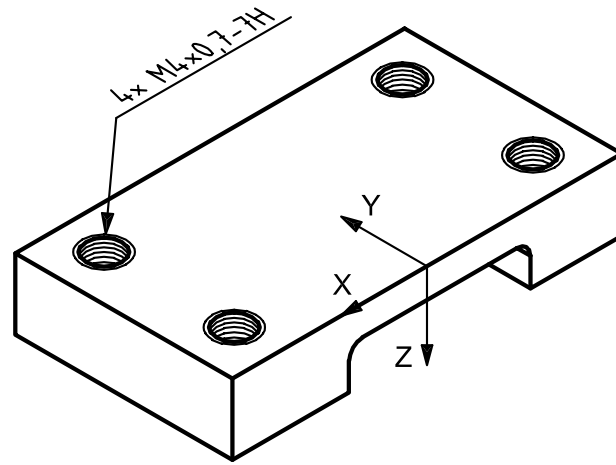

a) Entry depth

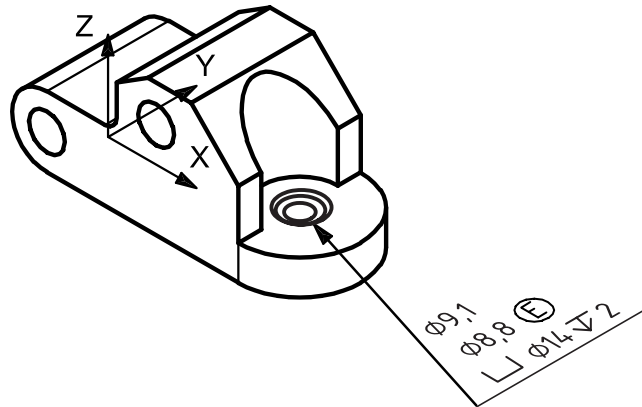

b) Counterbore

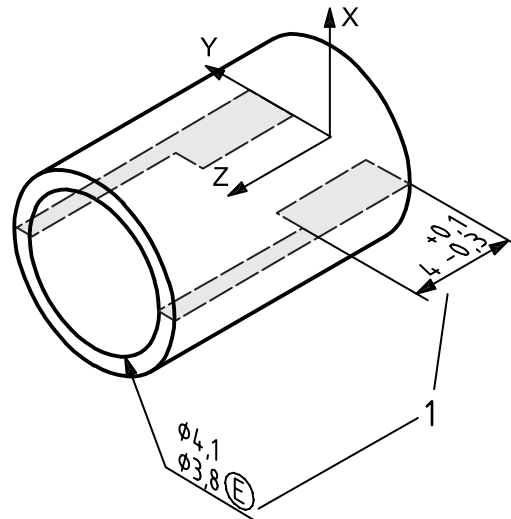

c) Remaining thickness

Key

- 1 associative group

Figure 25 — Attachment techniques — Depth, spotface, remaining thickness

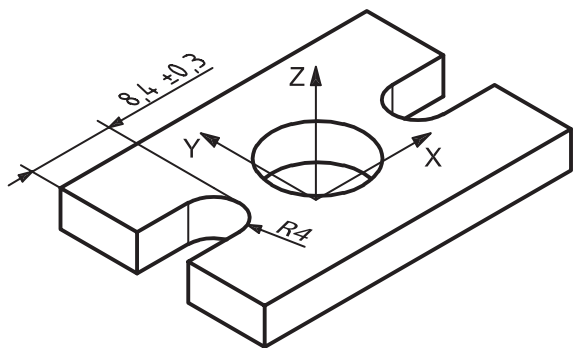

a) Notches example 1

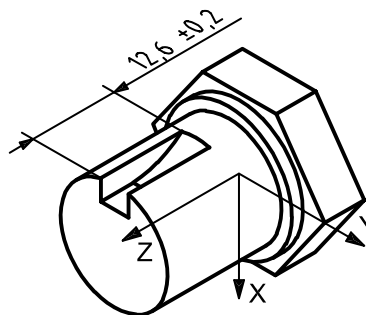

b) Notches example 2

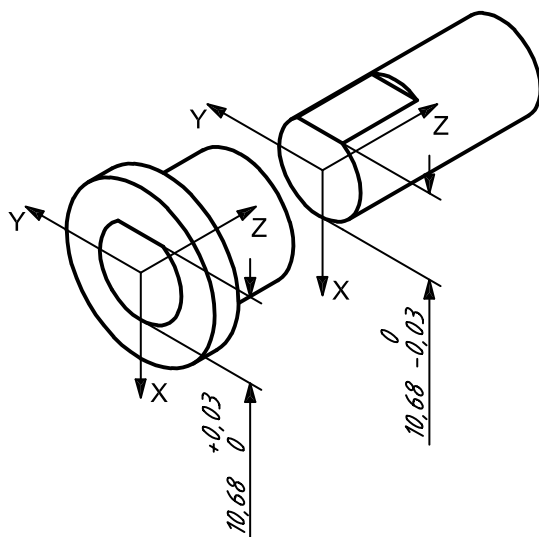

c) Flats on cylinders

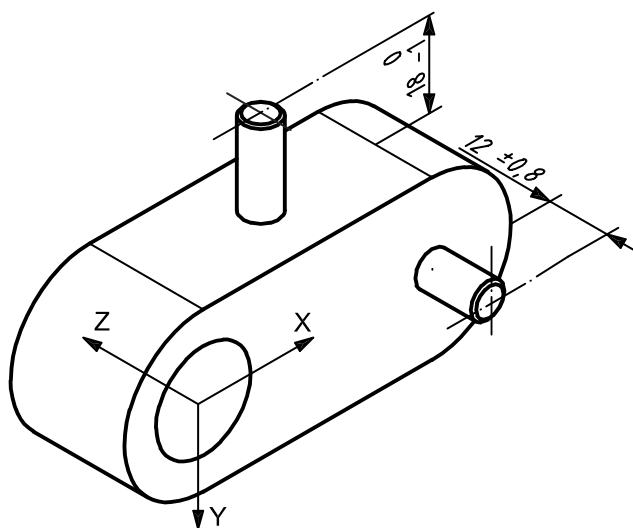

d) Pin heights

Figure 26 — Attachment techniques — Notches, flats, and pin heights

9.4 Drawing requirements

Theoretically exact dimensions not displayed on a drawing shall be obtained by querying the model. Requirements for dimensions on axonometric views of a drawing are as follows.

- Displayed dimensions in views are true dimensions. Dimensions shown in an axonometric view shall be actual values (not out of scale);
- Displayed theoretically exact dimensions shall be enclosed in a frame in accordance with ISO 1101;
- Leader lines shall be used to relate a dimension to a cylindrical model feature. The leader line shall be directed to the intersection of the cylindrical model feature and a surface. Leader lines shall terminate with an arrowhead;
- The existing drawing standards for plus and minus tolerances shall be used. These shall include those according to ISO 129-1 and ISO 14405;
- When limits and fits dimensions are used on drawings, ISO 286 shall be applied.

10 Datum applications

10.1 General

This clause establishes practices for organizing, attaching, and displaying datum indicators, datum target indicators, and related information associative with models. Requirements and recommendations for correlating datum features to the coordinate axes of the model space are given.

10.2 Common requirements

There are no common exceptions or additions between models and drawings.

10.3 Model requirements

10.3.1 Datum systems and model coordinate systems

The following requirements apply to the relationship between the datum systems on the model and the model coordinate systems.

a) Datum system and coordinate system correspondence

Each datum system shall be associated to a corresponding model coordinate system.

b) Datum system and coordinate system associativity

A definite visual relationship between any datum system and the corresponding coordinate system shall be preserved throughout navigation and query of the presented design data.

c) Multiple datum system and coordinate systems relationship

When more than one datum system is imposed upon a model, each datum system-to-coordinate system relationship shall be clearly presented and maintained. See [Figures 27](#) a), b) and c) for an example of multiple datum systems and coordinate systems organized in a single design presentation.

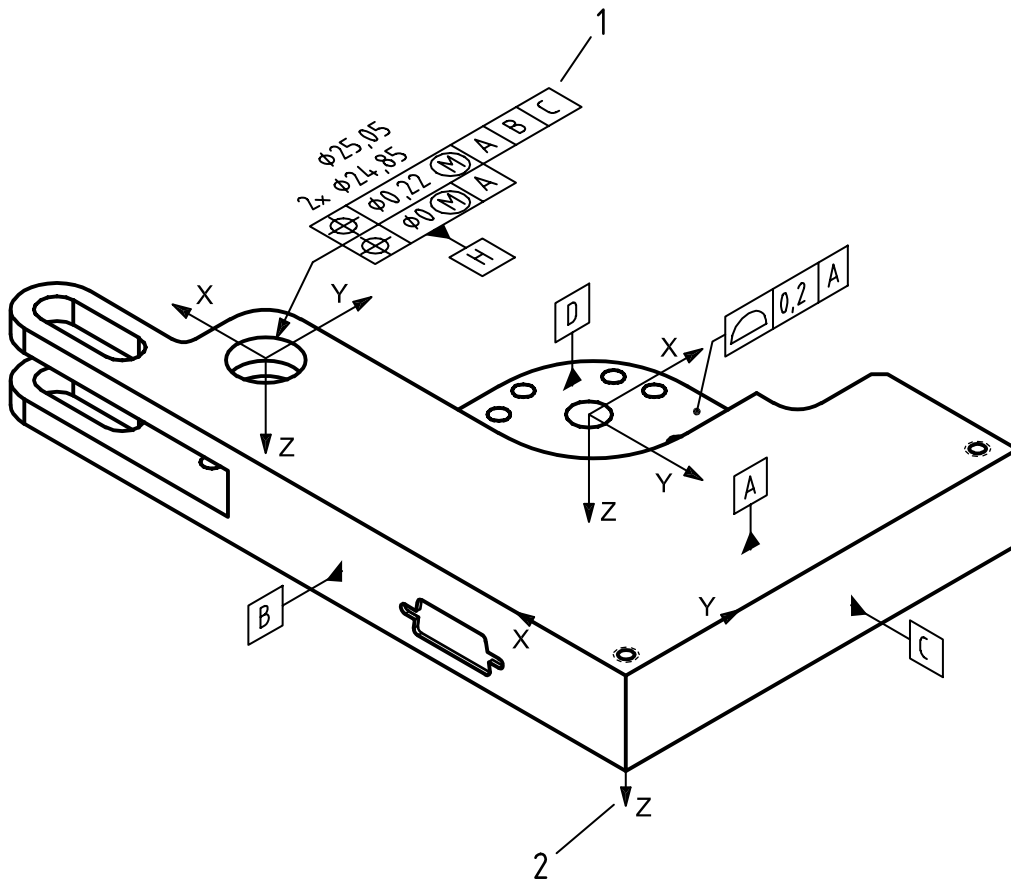

a) Absolute coordinates corresponding to a datum system

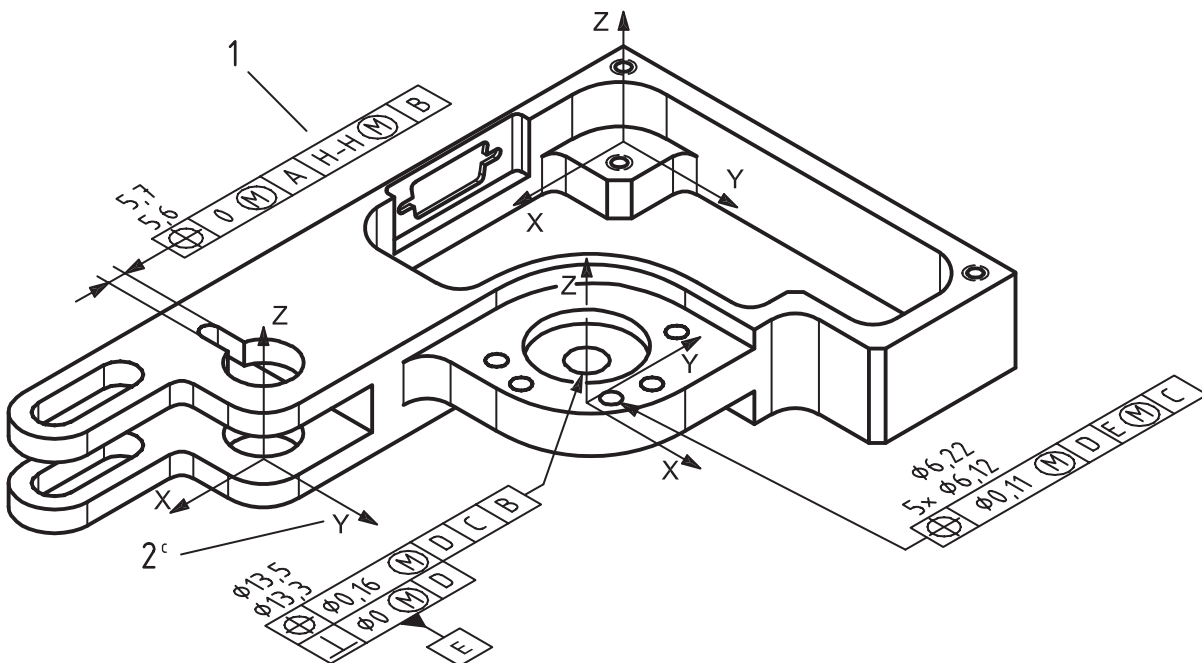

b) User-defined coordinates corresponding to a datum system

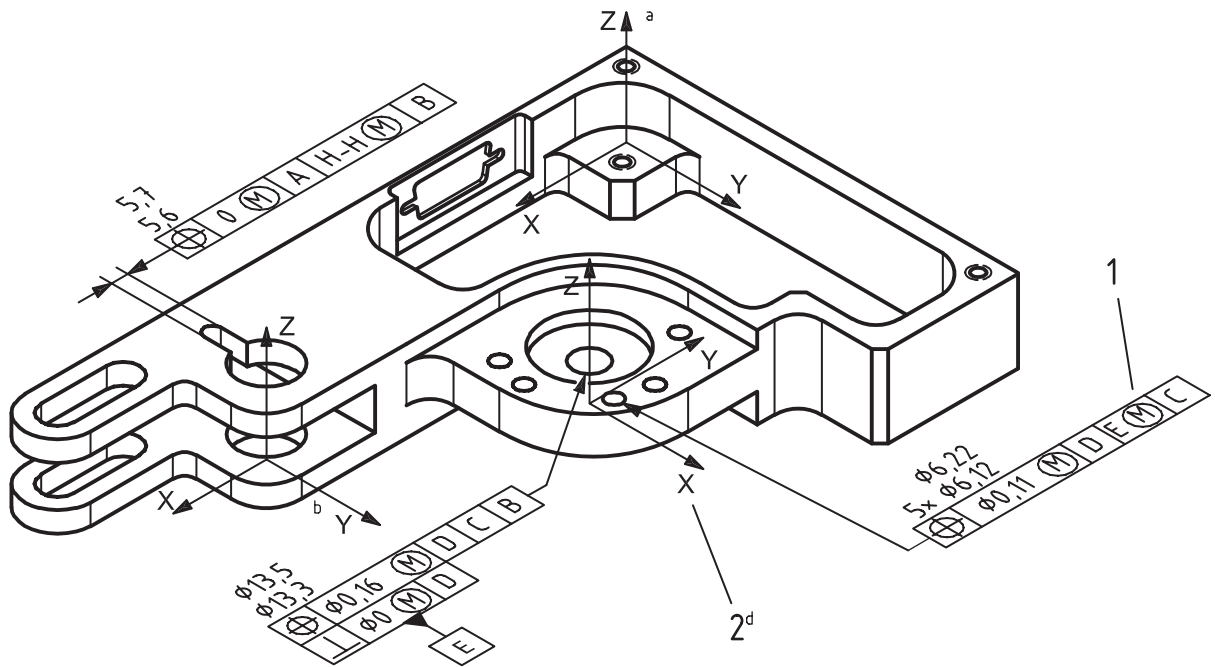

c) Multiple user-defined coordinate systems

Key

- 1 datum reference query
- 2 visual response
- a Absolutes.
- b User-defined.
- c User-defined coordinate system is the only result of this query.
- d User-defined coordinate systems are the only result of this query.

Figure 27 — Datum systems and coordinates relationship

10.3.2 Identification of datums

[Figure 28](#) demonstrates symbol attachment methods for identifying datums on a model. The datum indicator should be attached to the surface representing the datum feature. Single extension lines of model feature outlines should not be used for attachment of datum indicators. Particular requirements and the preferred attachment methods for datum indicators are as follows.

a) **Identification of planar integral feature**

Place the datum indicator on an annotation plane perpendicular to the integral feature [see datum A in [Figure 28 a](#)].

b) **Identification of spherical integral feature**

- Identification of a centre point as a datum: attach the datum indicator to the leader line of a dimension as shown in [Figure 28 a](#)). The datum indicator may also be attached to the tolerance frame as shown in [Figure 28 b](#)).

c) **Identification of cylindrical integral feature**

- Identification of a line on a surface as a datum: attach the datum indicator to a reference line and using a leader line terminated with a dot to the surface.
- Identification of an axis as a datum: attach the datum indicator to the leader line of a dimension as shown in [Figure 28 a](#)). The datum indicator may also be attached to the tolerance frame as shown in [Figure 28 b](#)).

d) **Identification of a set of two opposed, parallel planes (a width)**

Place the datum indicator and the dimension and extension lines on an annotation plane perpendicular to the width centre plane. The size limits shall be organized and displayed similarly as shown.

- Identification of a median plane as a datum: attach the datum indicator as an extension of the dimension line as shown in [Figure 28 a](#)) or to the tolerance frame as shown in [Figure 28 b](#)).

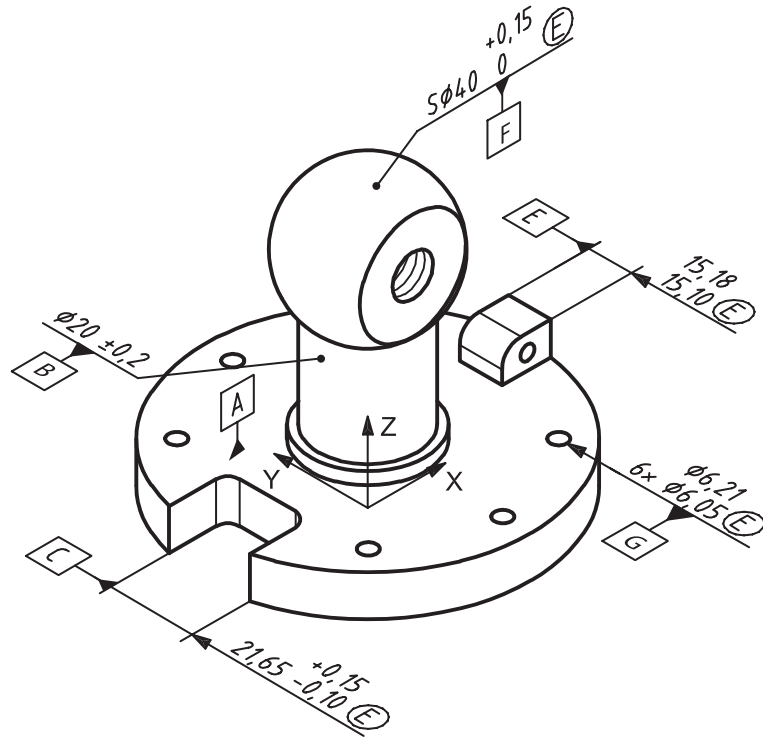

a) Direct attachment

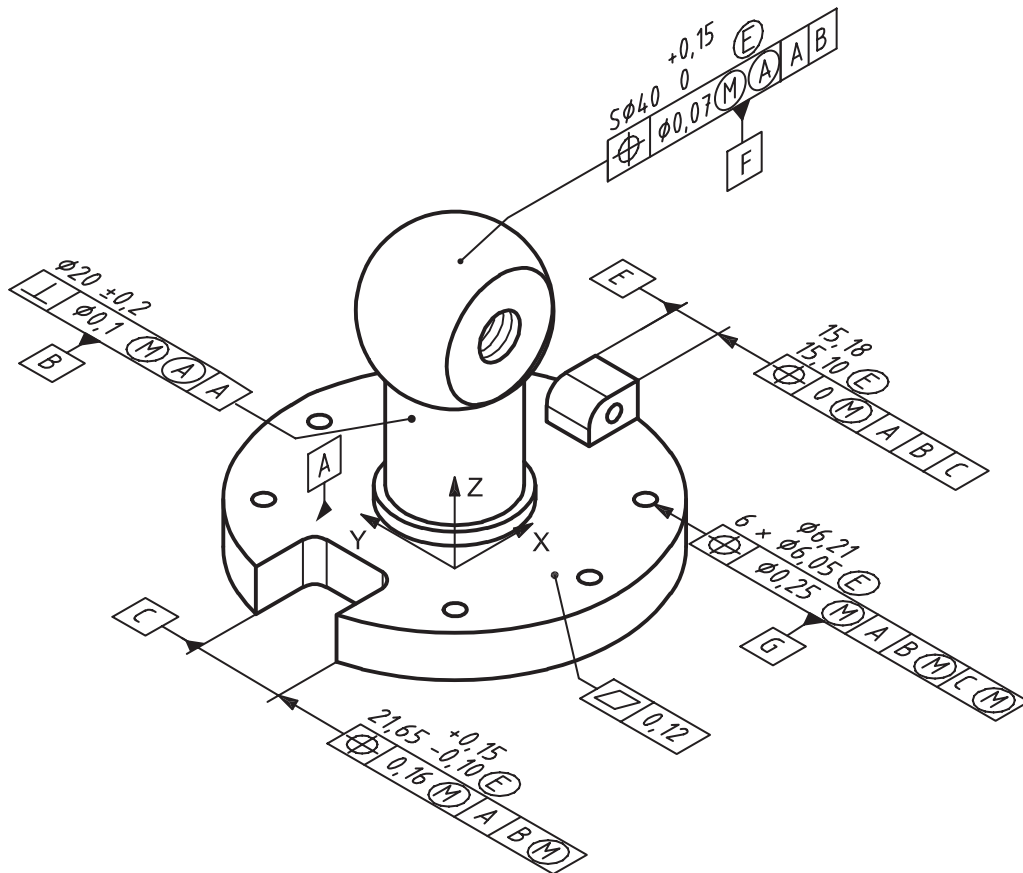

b) Tolerance frames

Figure 28 — Datum indicator attachments

e) **Identification of restricted area application**

When the surface containing a datum feature also contains an area of limited application of a geometric tolerance, represent the restricted area of application on the model using supplemental geometry (see [Figure 29](#)).

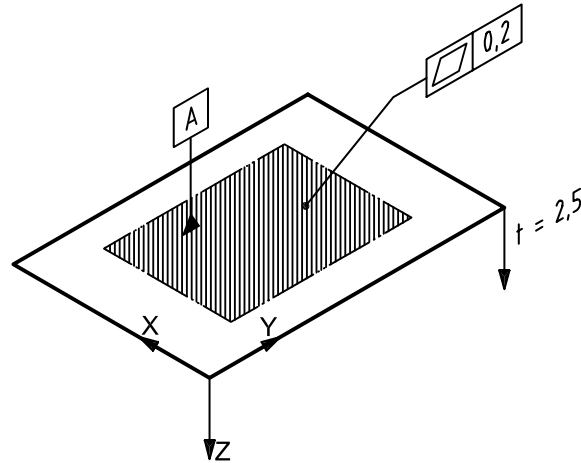

Figure 29 — Partial surface as a datum feature

10.3.3 Associativity of datum features and design data

A query of any datum feature shall permit access to all relevant information for the datum feature. This includes the datum indicator, the size limits (if applicable), any applied geometric tolerance, and the relevant coordinate system.

10.3.4 Datum target identification and attachment

The following gives the requirements and other provisions for attaching, associating, and displaying datum target indicators on models (see [Figure 30](#)).

- a) When establishing a datum axis from a single internal cylindrical surface, datum targets can be used, for example, as shown in [Figure 31](#).
- b) When establishing a datum axis from two external cylindrical surfaces, datum targets from the two surfaces may be used, for example, as shown in [Figure 32](#).
- c) Datum target areas shall be shown using shading or crosshatching.

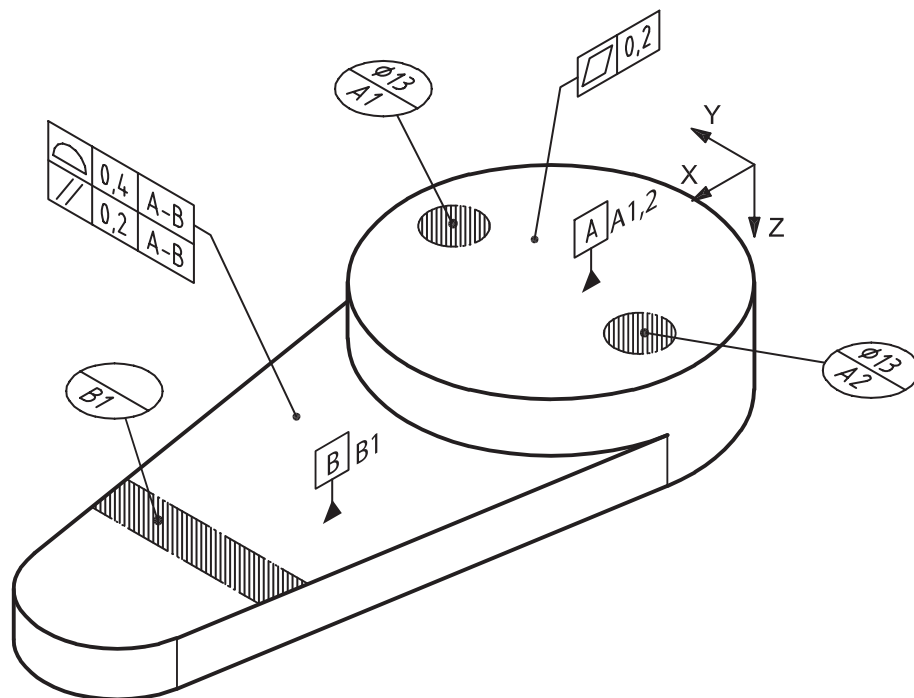
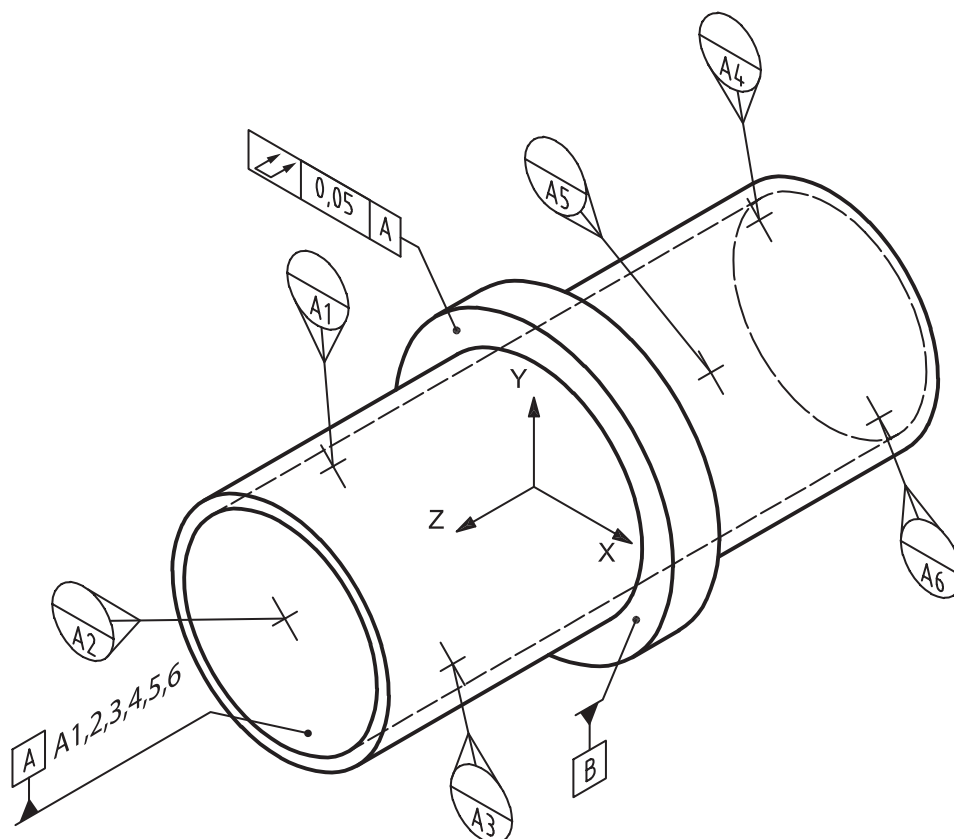
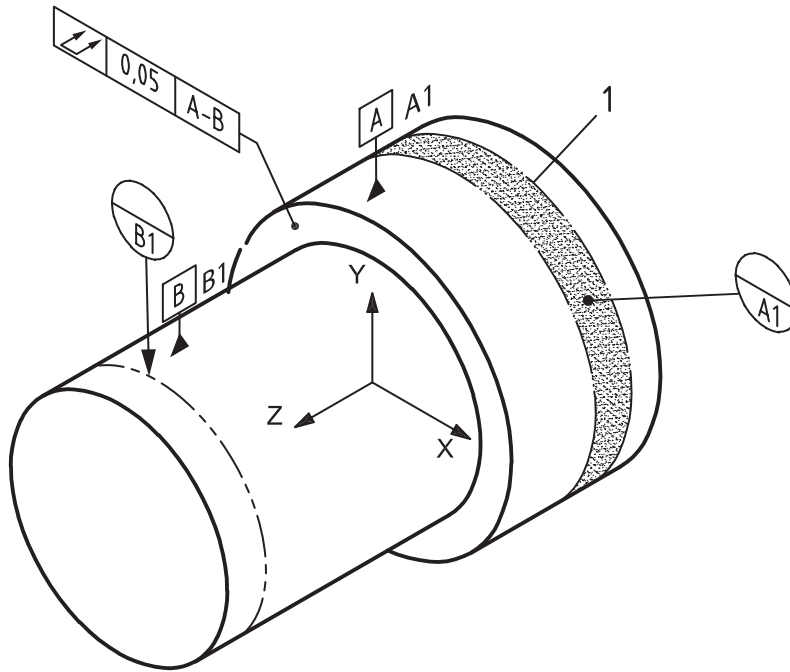

Figure 30 — Datum targets and indicators attachment



NOTE This figure shows a special display of the model to allow the termination of the leaders on internal surfaces of the model to be seen.

Figure 31 — Target points establishing a datum axis on an internal cylindrical surface



Key

1 cylindrical target datum

Figure 32 — Two cylindrical features establish a datum axis

10.3.5 Multiple features establishing a datum

When two or more features are combined to establish a datum, associativity shall be established in the design presentation. For several common instances, the following display and associativity requirements apply.

- a) When a pattern of features of size is used to establish a datum axis, the involved model features and any applied tolerance for these model features shall be organized as an associated group (see [Figure 33](#)).
- b) When two or more coaxial and cylindrical datum features are used to establish a single, common datum axis, the involved model features and any applied tolerance for these model features shall be organized as an associated group (see [Figure 34](#)).
- c) When two or more co-planar surface features are used to establish a datum plane, the involved model surfaces and any applied tolerance for these surfaces shall be organized as an associated group (see [Figures 35](#) and [36](#)).

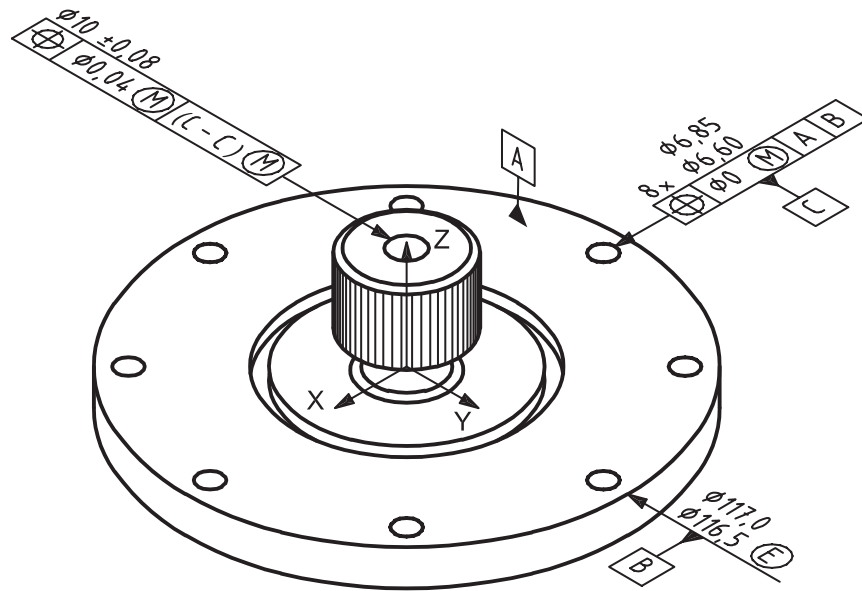

a) Placement and attachment

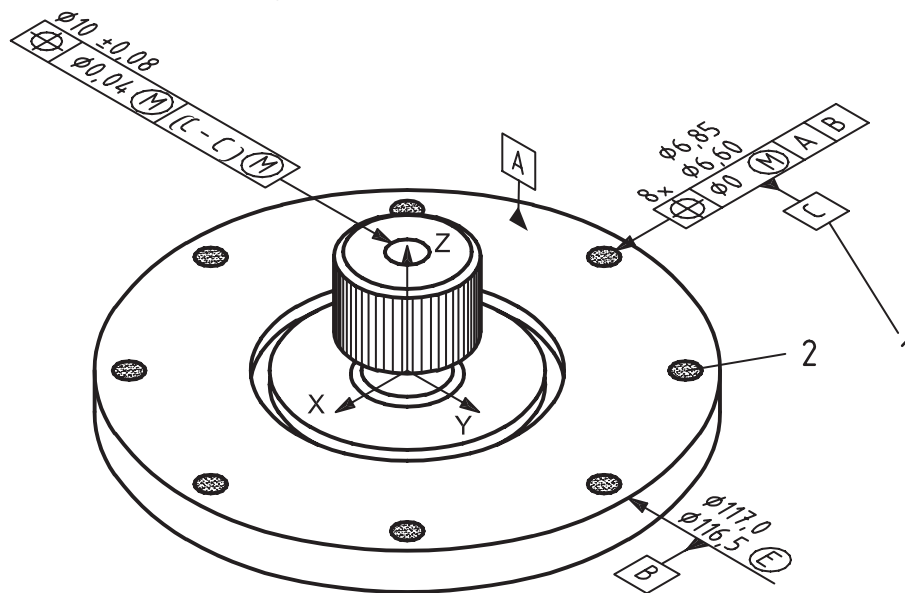

b) Datum feature indicator associativity

Key

- 1 query
- 2 visual response

Figure 33 — Pattern of features establish a datum axis

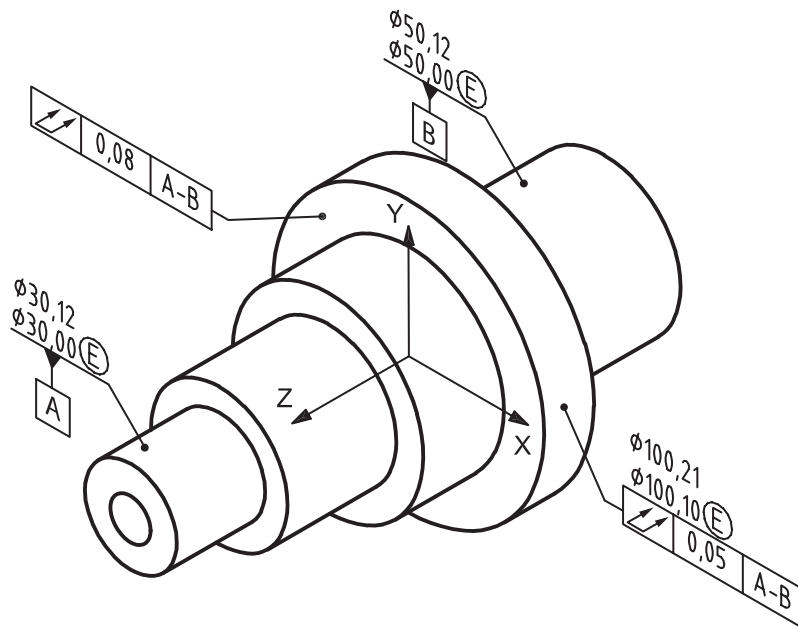
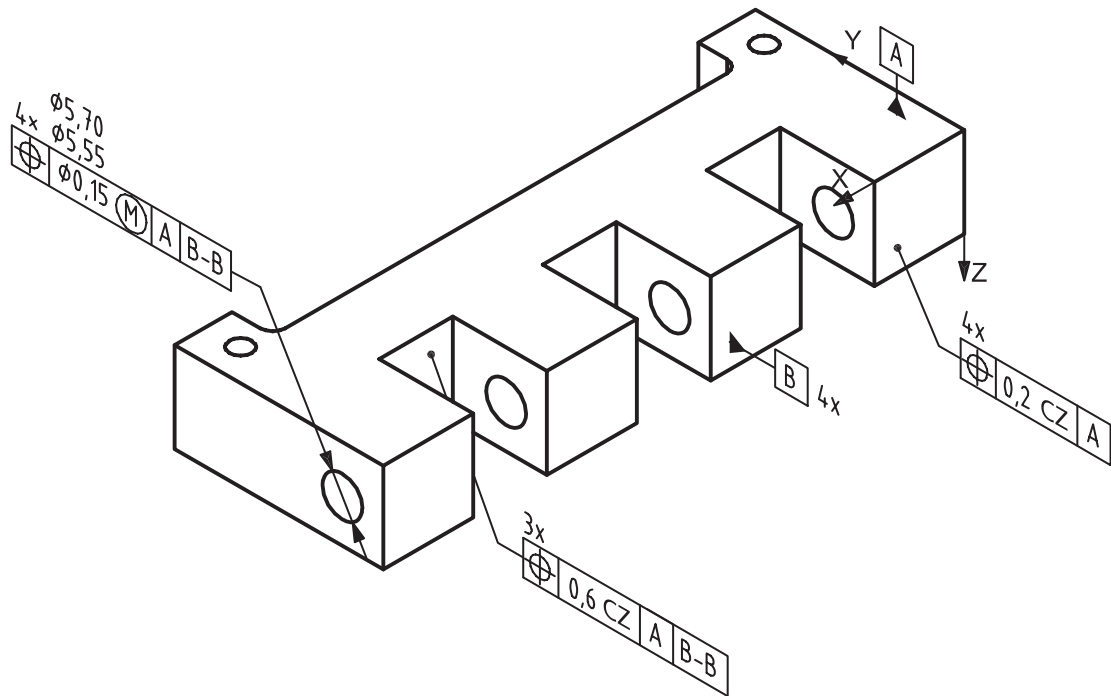
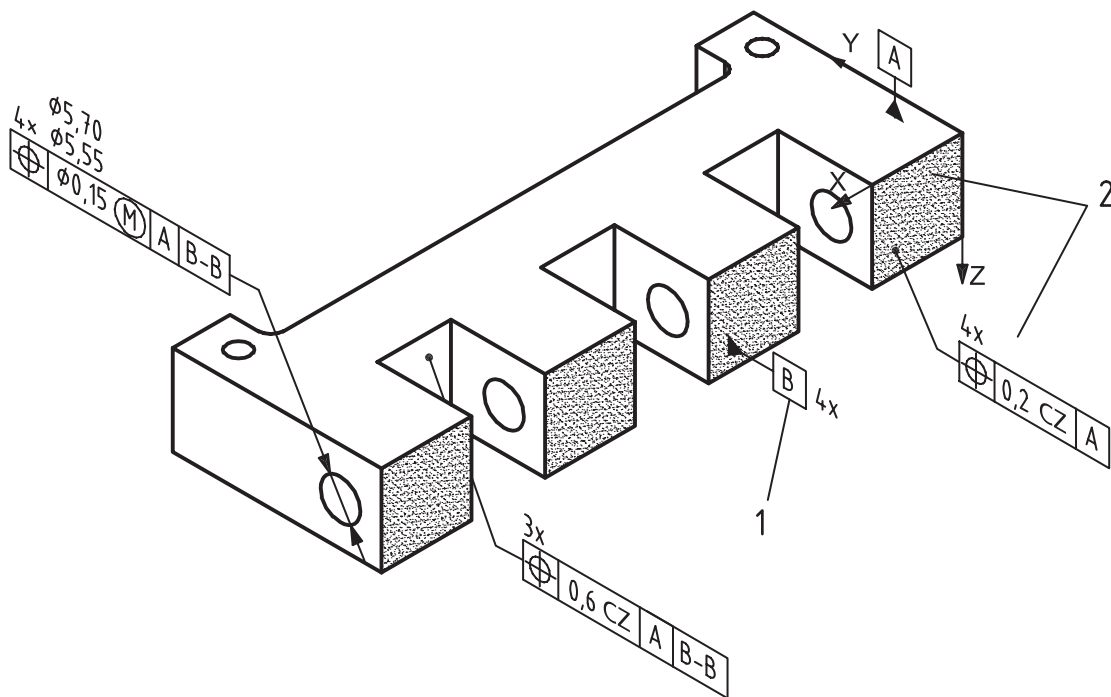

Figure 34 — Two coaxial features establish a datum axis



a) Placement and attachment



b) Datum feature indicator associativity

Key

- 1 query
- 2 visual response

Figure 35 — Co-planar surfaces establish a datum plane

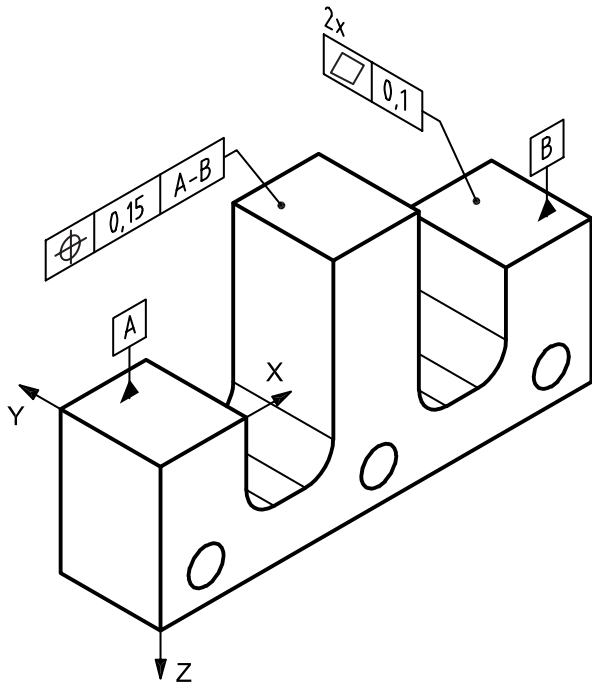

a) Placement and attachment

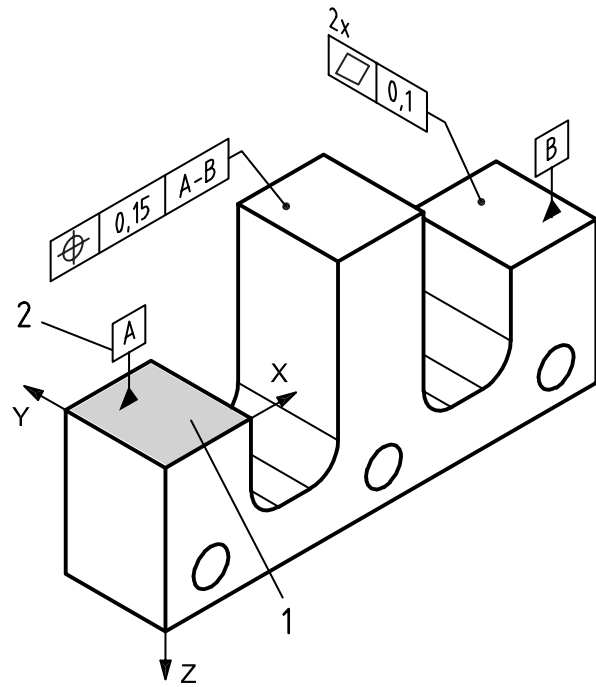

b) Datum feature indicator associativity

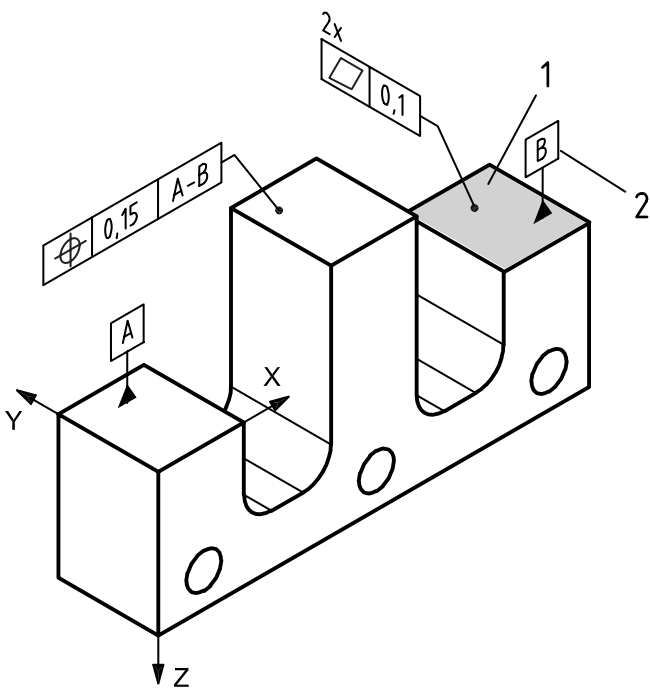

c) Datum feature indicator associativity

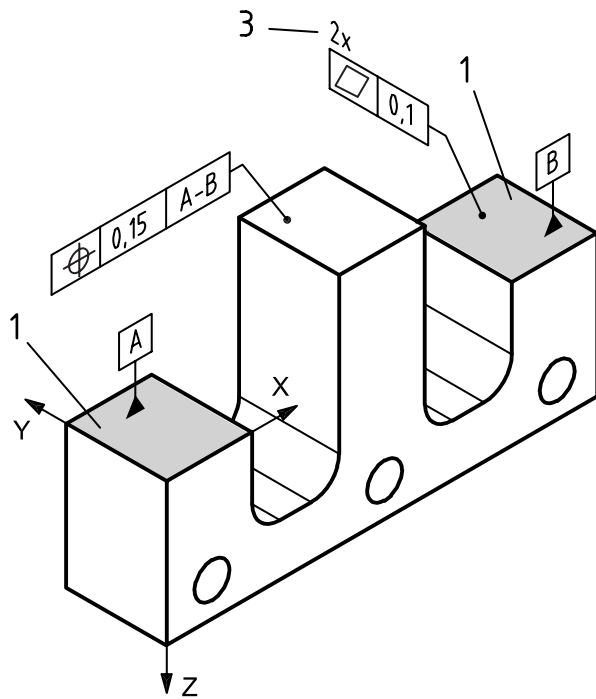

d) Tolerance frame associativity

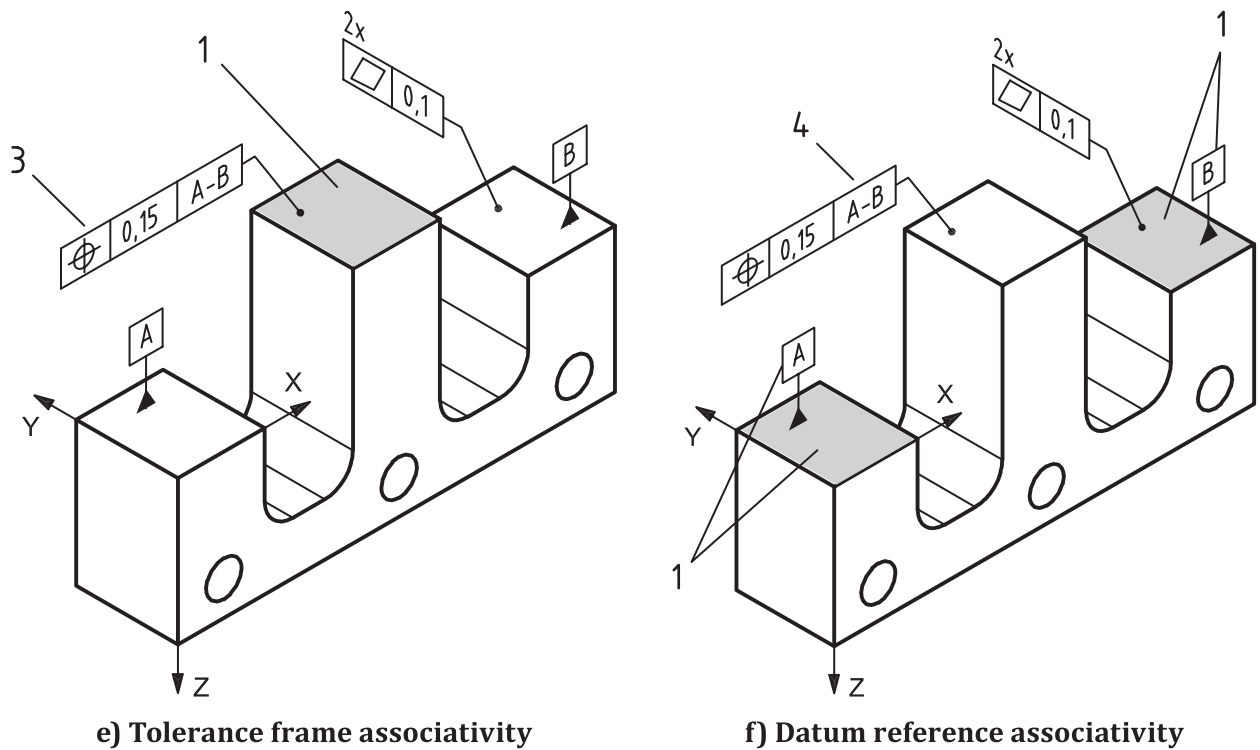
**Key**

- 1 visual response
- 2 datum indicator query
- 3 tolerance frame query
- 4 datum reference query

Figure 36 — Separated surfaces establish a datum plane

10.4 Drawing requirements

The following are requirements and other provisions for datum features in axonometric views.

- a) The corresponding model coordinate system shall be displayed in each axonometric view in which a datum system is cited.
- b) Identification of datum features in axonometric views
 - The datum indicator should be attached to the surface of the represented object. A single extension line of a model feature outline should not be used for attachment of datum indicators in an axonometric view (see [Figure 37](#)).
 - Datum indicators may be attached to the dimension for features of size when the feature is used to define a datum (see [Figure 28](#)).

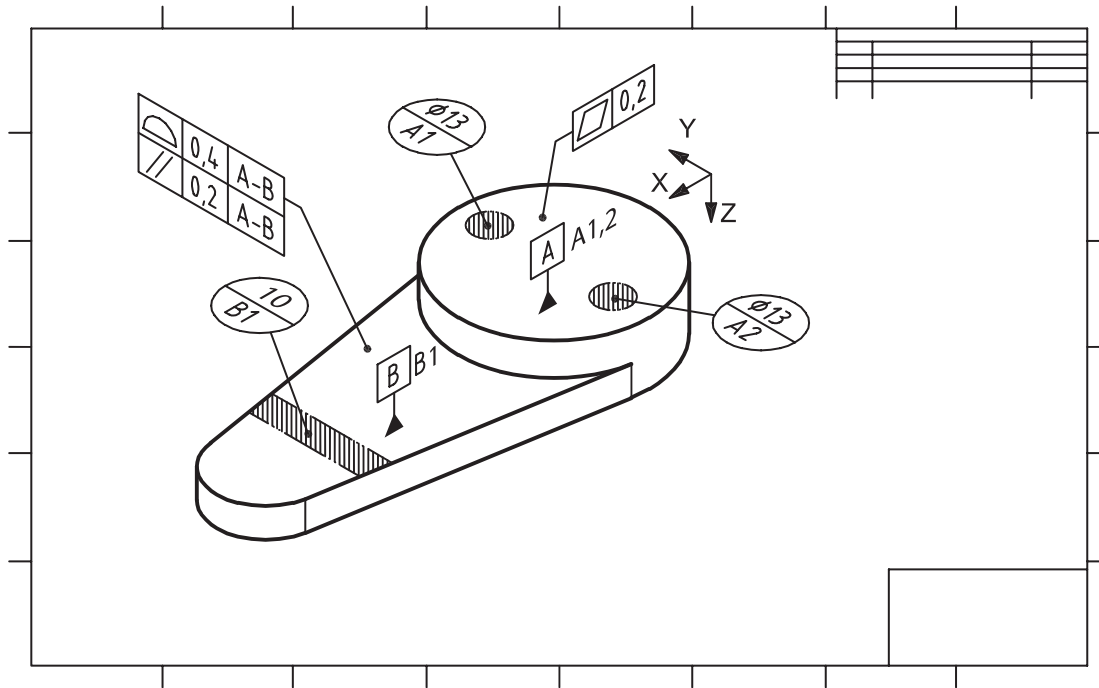

Figure 37 — Datum targets and indicators in an axonometric view

11 Geometric tolerances

11.1 General

This clause establishes the placement, attachment, and display requirements and other provisions for geometric tolerances.

11.2 Common requirements

A general note defining a geometric tolerance may be specified. More than one tolerance can be specified.

11.3 Model requirements

11.3.1 General

The following subclauses address the placement, attachment, and display requirements and other provisions for geometric tolerances associated with model features.

11.3.2 Form tolerances

The tolerance frame shall be placed on an annotation plane parallel to, perpendicular to, or coincident with the surface to which it applies using the attachment methods given in [Table 3](#) (see [Figure 38](#)).

- a) Show the tolerance frame which is applicable to a restricted feature using supplemental geometry on the model to indicate the area. Direct a leader line from the tolerance frame to the represented area (see [Figure 29](#)).
- b) When a roundness tolerance is applied to a sphere, cylinder, cone, or surface of revolution, the tolerance frame shall be placed on an annotation plane perpendicular to the model feature axis or containing the centre point of a sphere (see [Figure 39](#)).

- c) When a straightness tolerance is applied to the line elements of a cylindrical or conical surface, the tolerance frame shall be placed on an annotation plane containing the axis of the model feature surface (see [Figure 44](#)).

Table 3 — Form tolerances

General application		Attachment technique		Figure
		Size	Directed leader line	
	Planar surface		X	38
	Restricted area		X	29
	Sphere		X	39 a)
	Cylinder		X	39 b)
	Conical surface		X	39 c)
	Surface of revolution		X	39 d)
	Cylinder		X	40 a)
	Planar surface		X	41
			X	42
			X	43
	Cylindrical or conical surface		X	44
	Median line	X		45

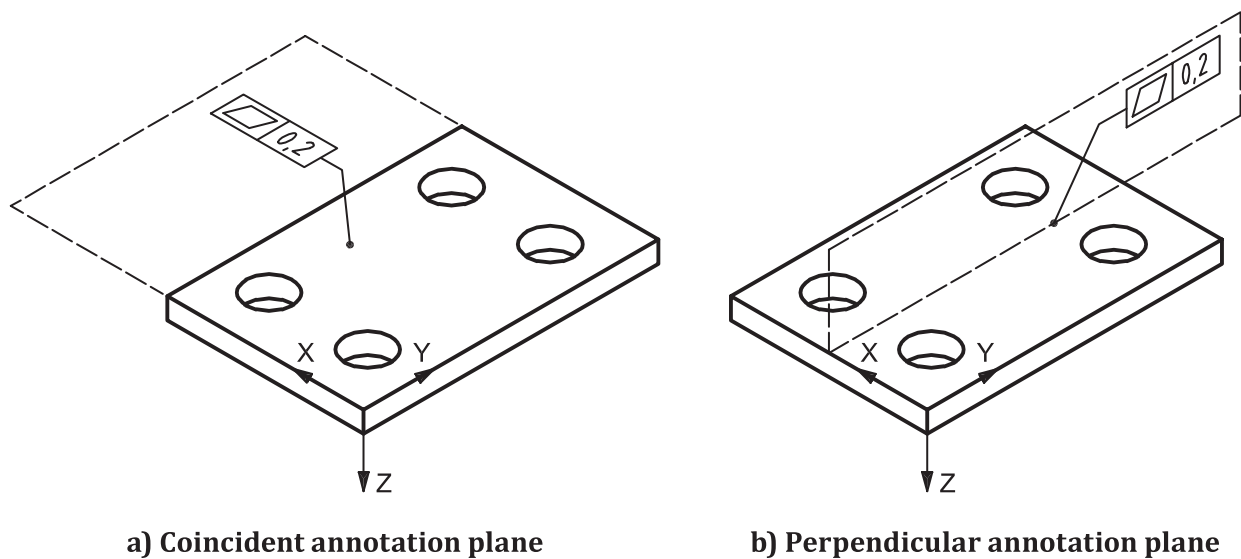

NOTE The annotation planes shown here as dashed lines are for clarification only and are not part of an actual presentation.

Figure 38 — General application of geometric tolerances' coincident or perpendicular annotation plane

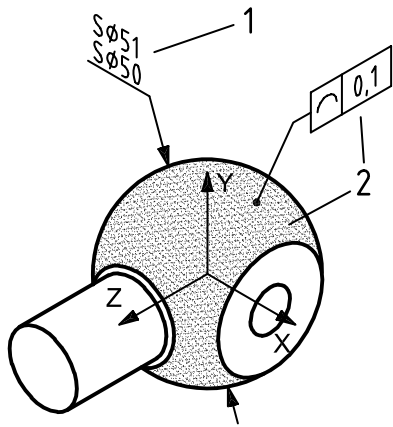

a) Sphere — Leader attachment

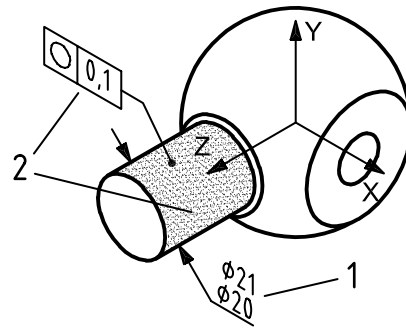

b) Cylinder — Leader attachment

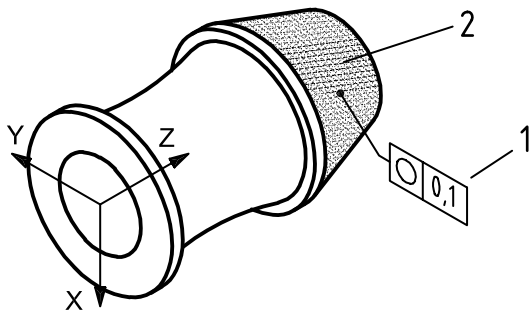

c) Conical surface

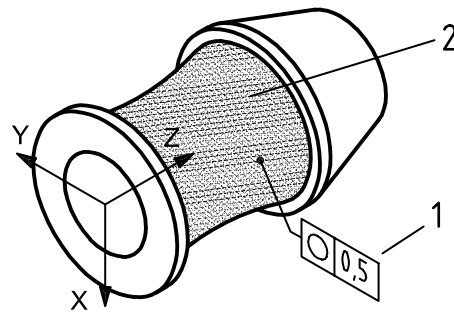

d) Surface of revolution

Key

- 1 query
- 2 visual response

Figure 39 — Roundness — Sphere, cylinder, conical, or revolved surface

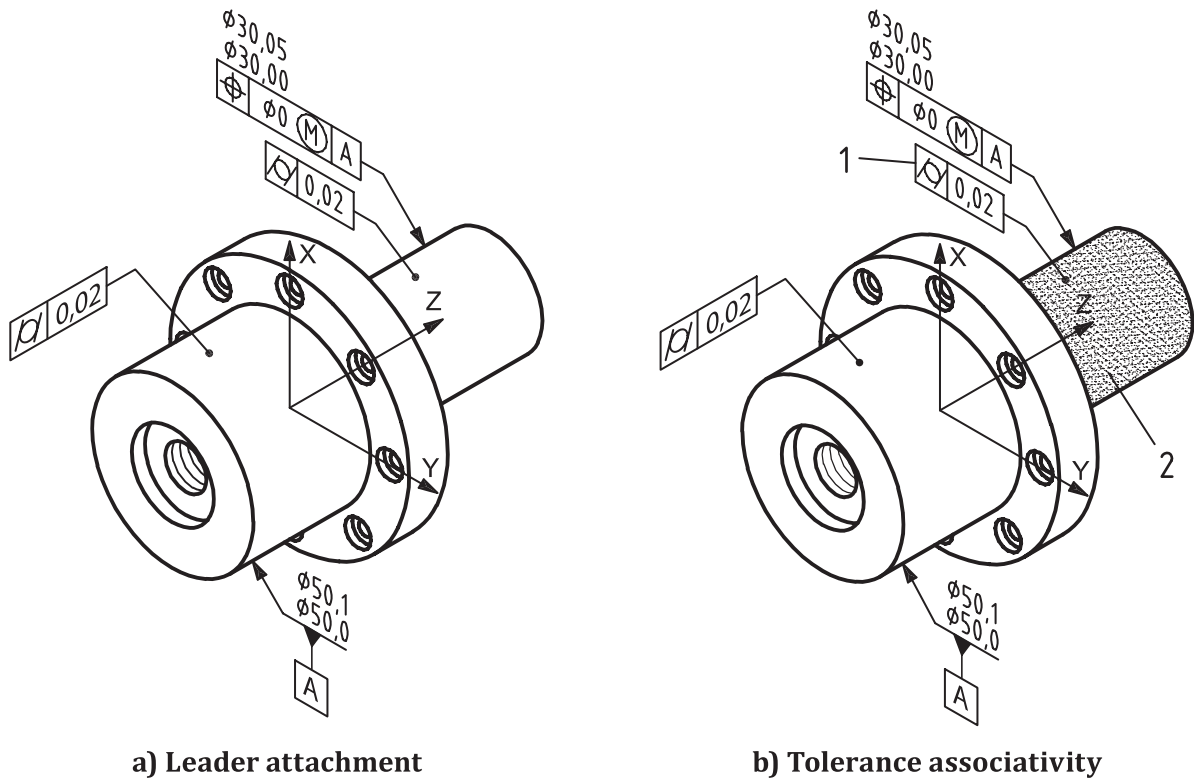

Key

- 1 query
- 2 visual response

Figure 40 — Cylindricity

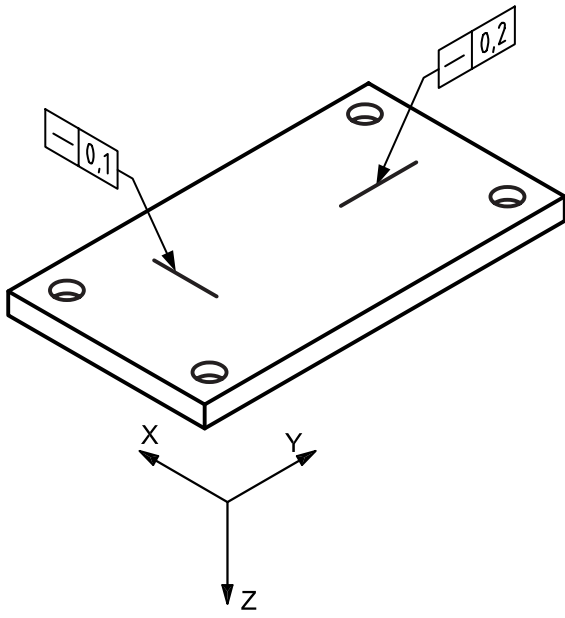

a) Placement and attachment

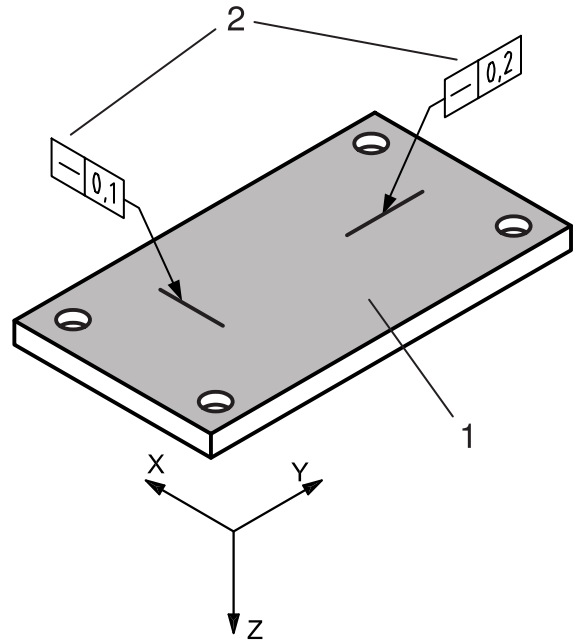

b) Feature associativity

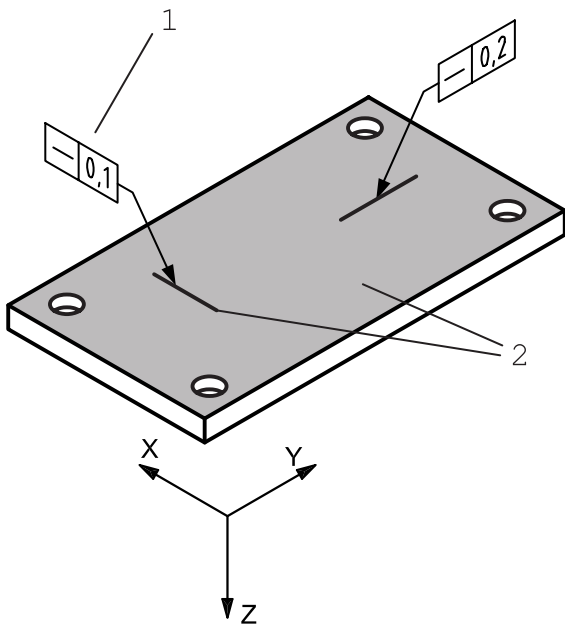

c) Tolerance direction associativity

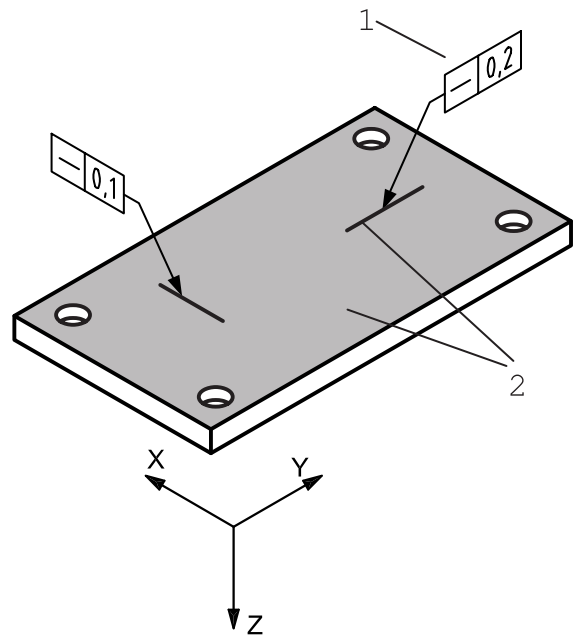

d) Tolerance direction associativity

Key

- 1 query
- 2 visual response

Figure 41 — Straightness — Directed by line element

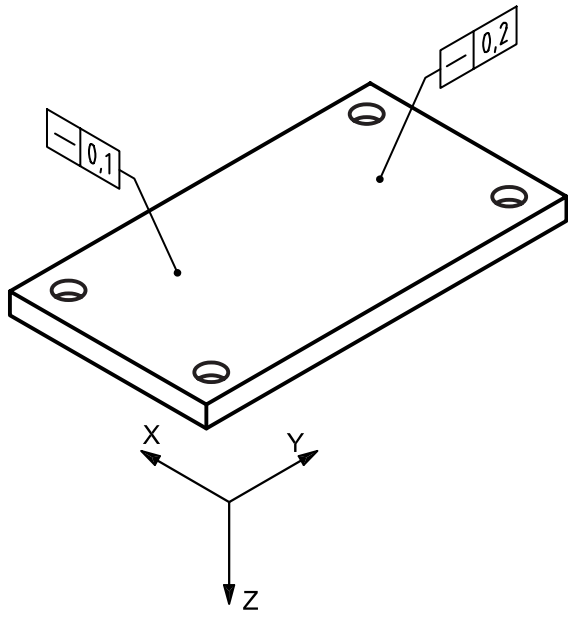

a) Placement and attachment

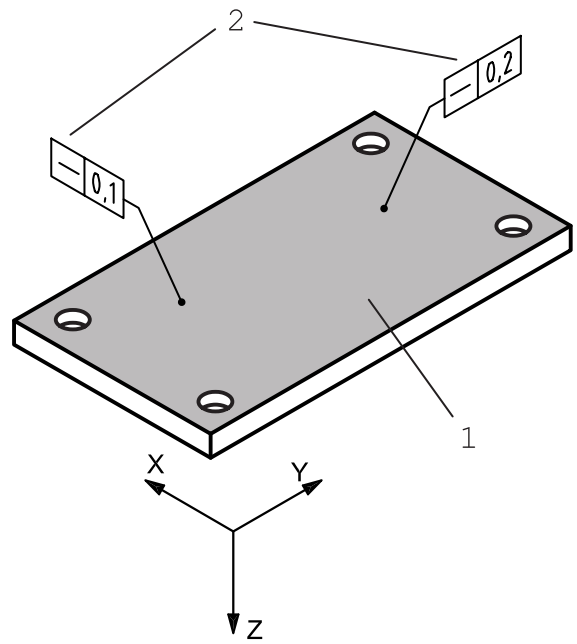

b) Feature associativity

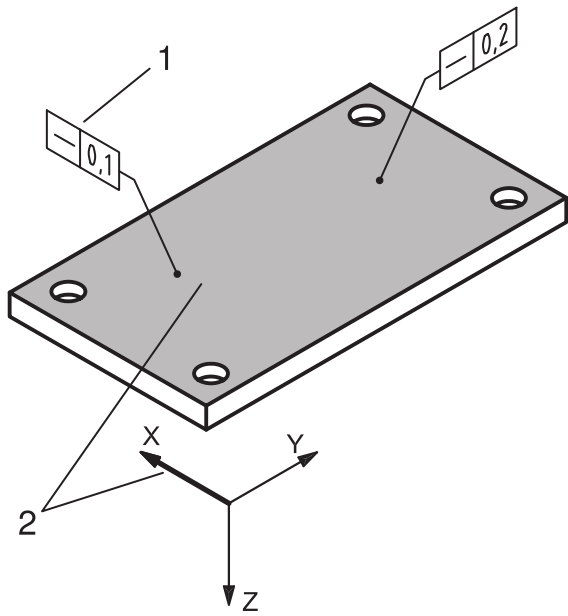

c) Tolerance direction associativity

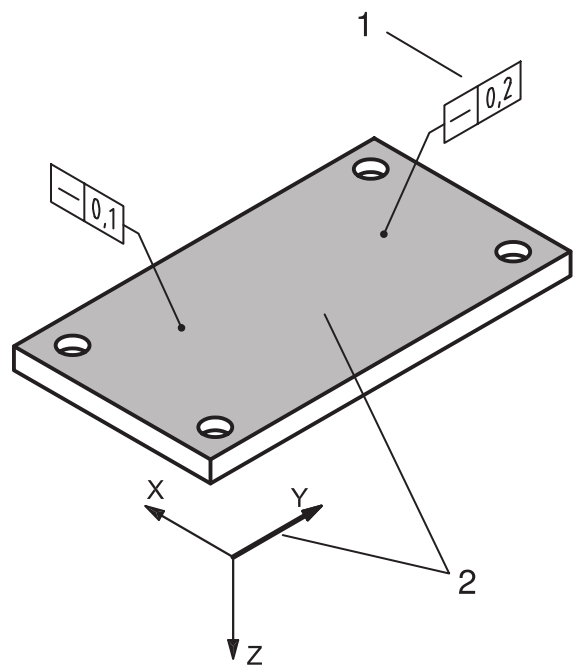

d) Tolerance direction associativity

Key

- 1 query
- 2 visual response

Figure 42 — Straightness — Directed by ordinate axis

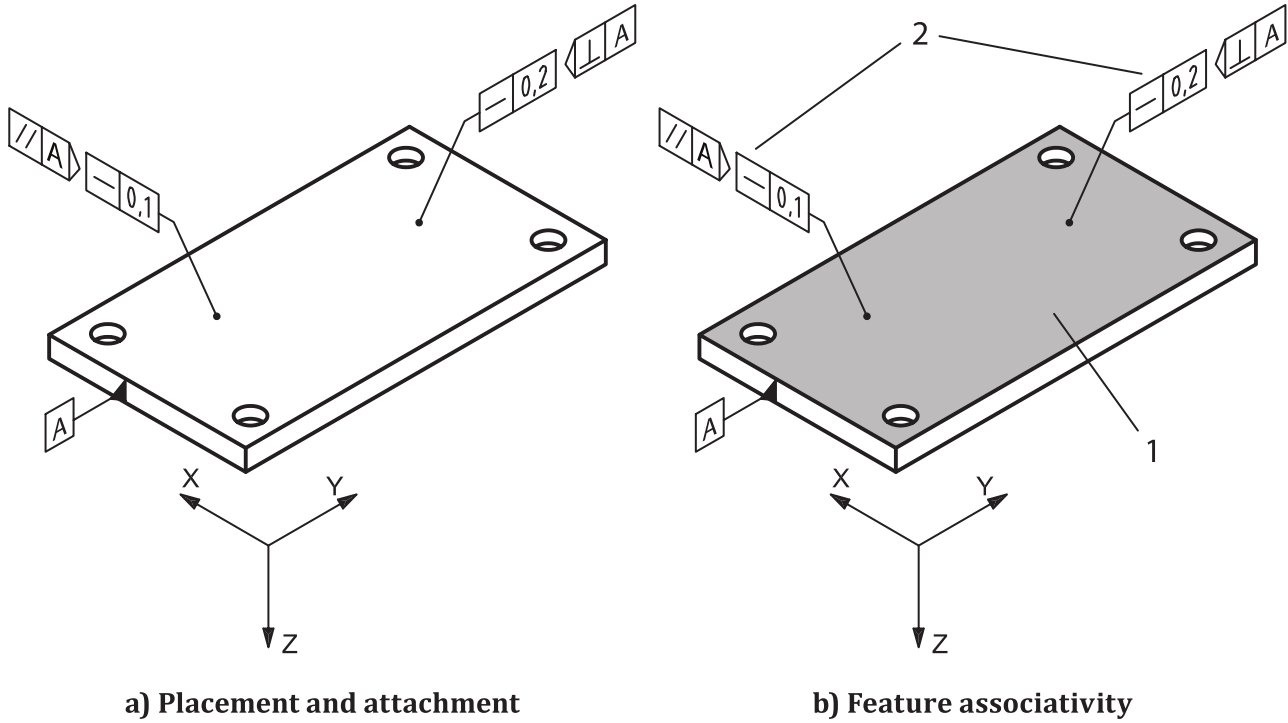

Key

- 1 query
- 2 visual response

Figure 43 — Straightness — Intersection plane indicator

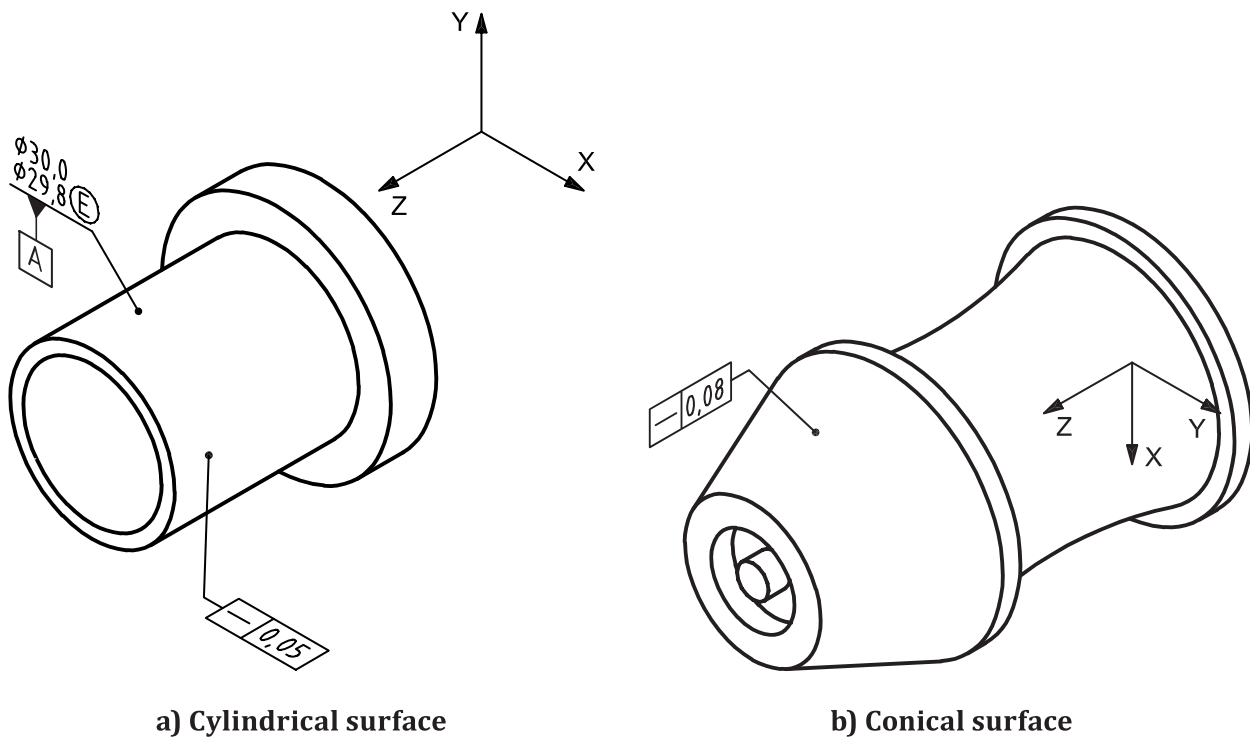

Figure 44 — Straightness — Cylindrical or conical surface

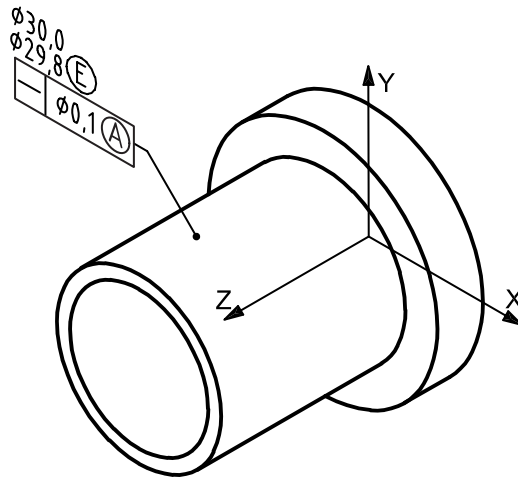

Figure 45 — Straightness — Median line

11.3.3 Orientation tolerances

The orientation tolerance frame shall be placed on an annotation plane parallel with, or perpendicular to, the referenced datum or primary datum using the attachment methods given in [Table 4](#).

- a) When each line element on a surface is directed by ordinate axis, the orientation tolerance frame and the appropriate modifier shall be placed on an annotation plane parallel with and perpendicular to the absolute coordinate system or an established user-defined coordinate system (see [Figure 48](#)).
- b) When using multiple datum references, the orientation tolerance frame and the appropriate modifier shall be placed on an annotation plane containing the represented line element indicating the direction of application (see [Figure 47](#)).
- c) When orienting a median line of a cylinder within a parallel planes tolerance zone, the orientation tolerance frame shall be attached to the diametral size and any other geometric tolerance requirement. The orientation of the dimension lines defines the orientation of the tolerance zone (see [Figure 51](#)).

Table 4 — Orientation tolerances

General application		Attachment technique			Figure
		Size	Directed leader line	Dimension lines	
	Flat surfaces		X		46
	Straight line on a flat surface		X		47 48
	Inclined flat surface		X		49
	Median line of cylinder	X			50 a)
	Median line of cylinder		X		50 b)
	Median surface of two opposed parallel surfaces	X			50 c)
				X	50 d)
	Median line — Within parallel plane's tolerance zone			X	51 a)
		X			51 b)

NOTE All three symbols are shown for applications that apply equally to perpendicularity, parallelism, and angularity.

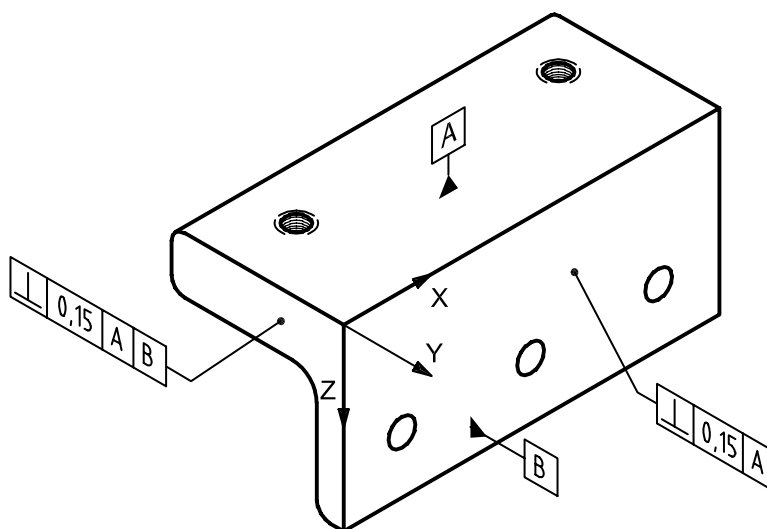
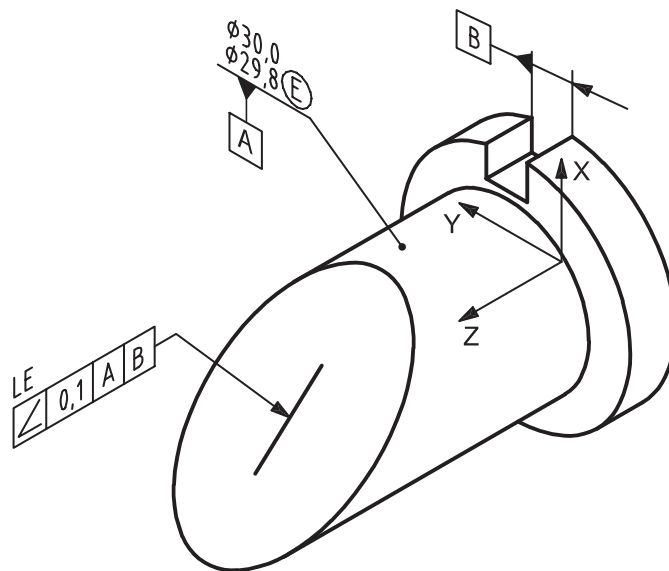
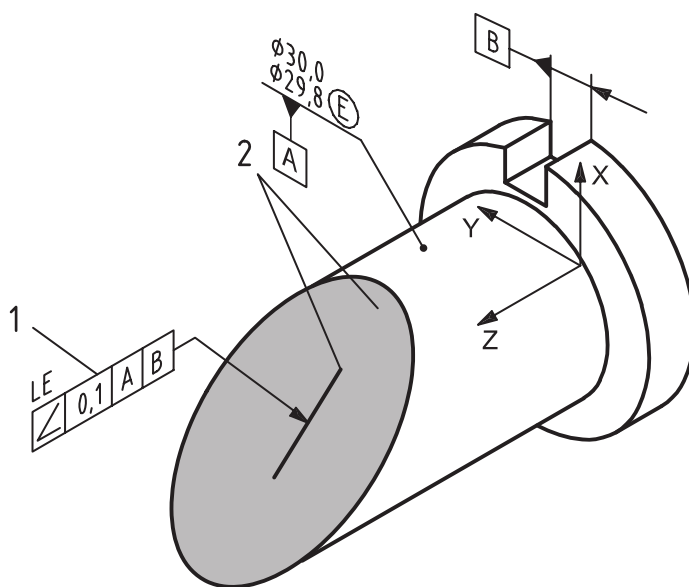

Figure 46 — Orientation — Planar surfaces



a) Placement and attachment of line element



b) Toleranced lines associativity directed by line element

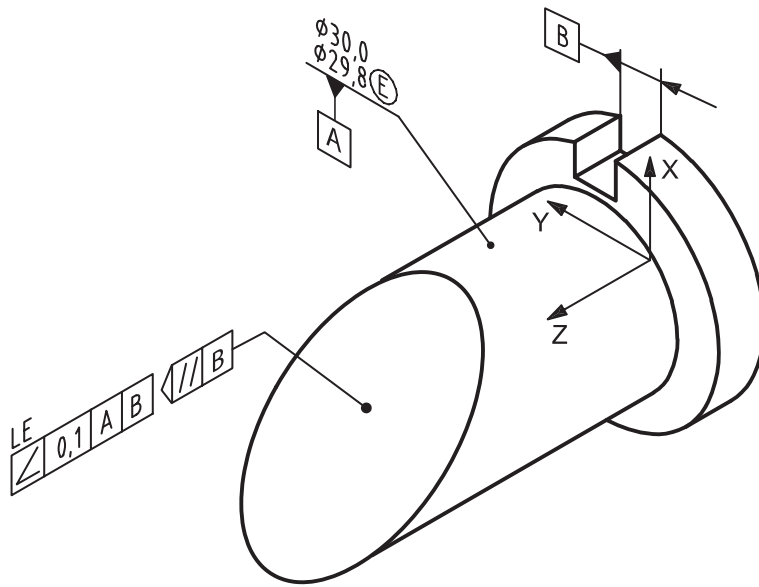

c) Placement and attachment of intersection plane indicator

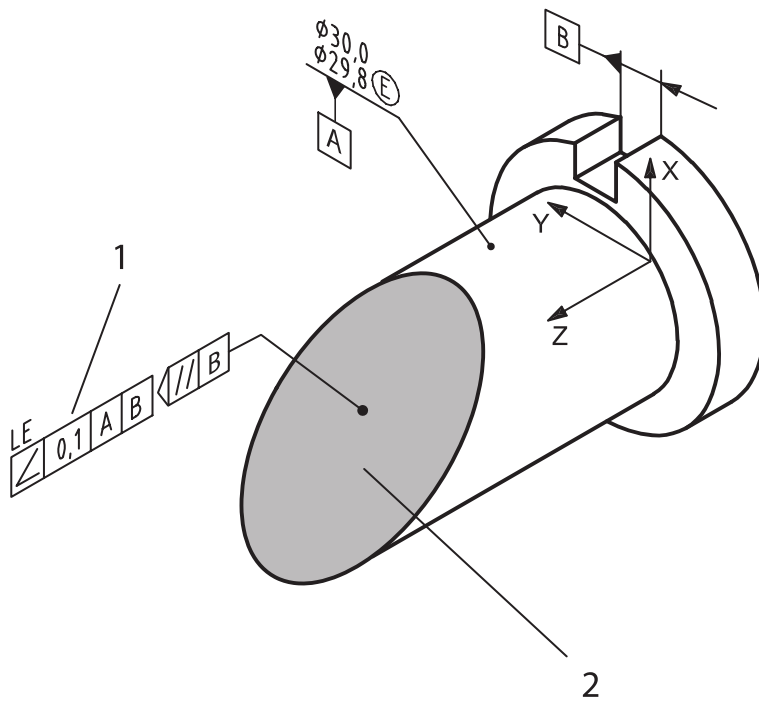

d) Associativity of intersection plane indicator

Key

- 1 query
- 2 visual response

Figure 47 — Orientation of each line element on a surface

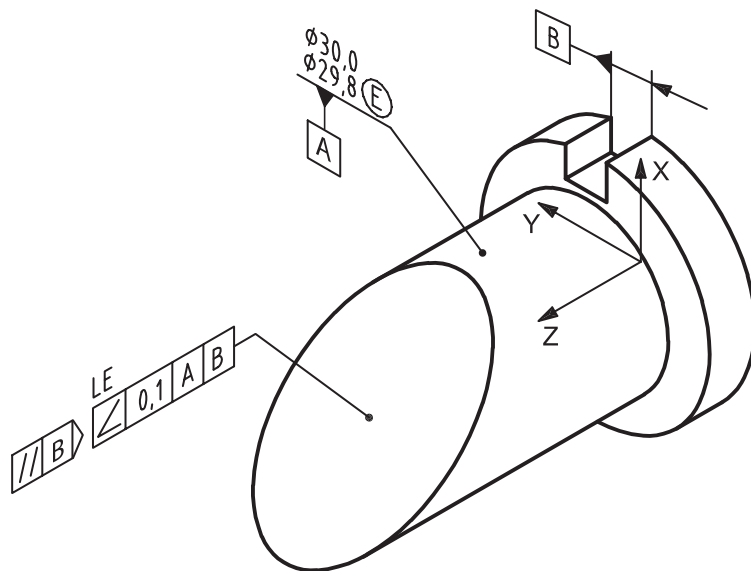

a) Placement and attachment

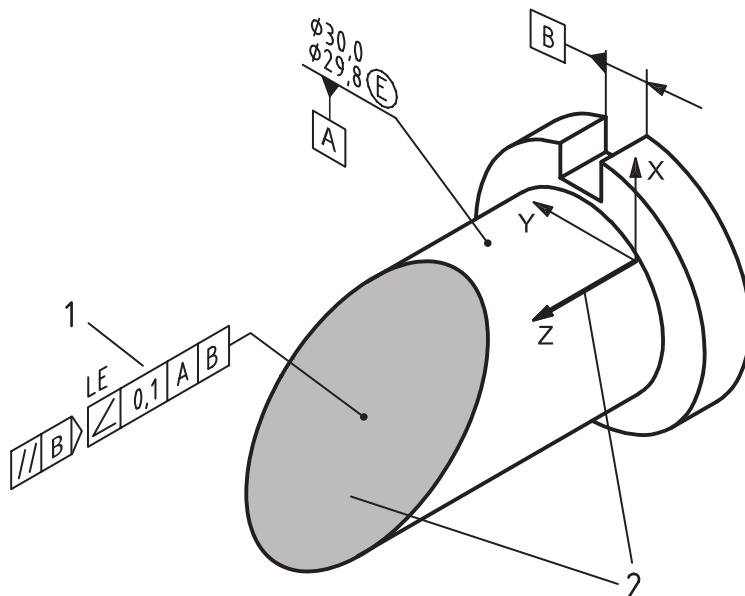

b) Toleranced lines associativity

Key

- 1 query
- 2 visual response

Figure 48 — Orientation of each line element on a surface — Directed by ordinate axes

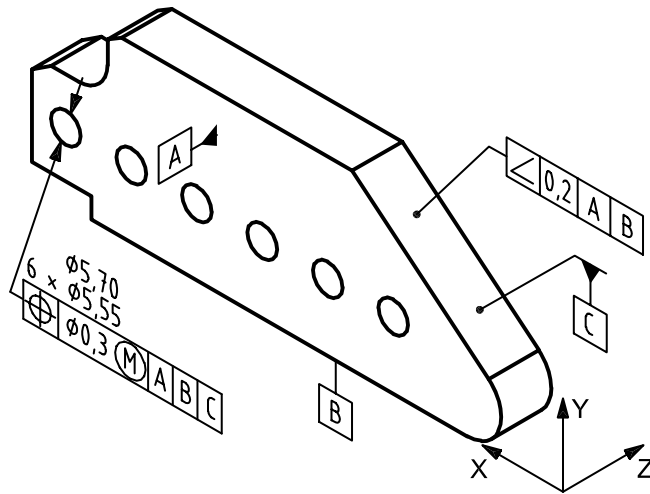

a) Placement and attachment

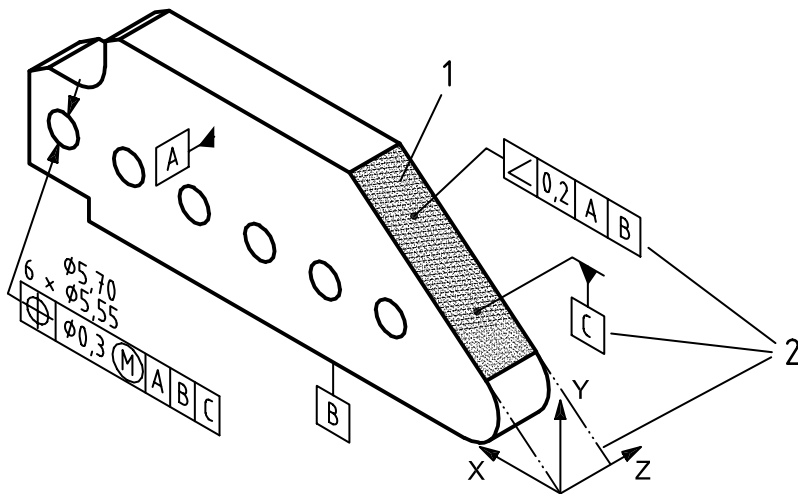

b) Theoretical counterpart associativity

Key

- 1 query
- 2 visual response
- a Supplemental geometry used to represent the theoretically exact counterpart.

Figure 49 — Orientation — Inclined surface

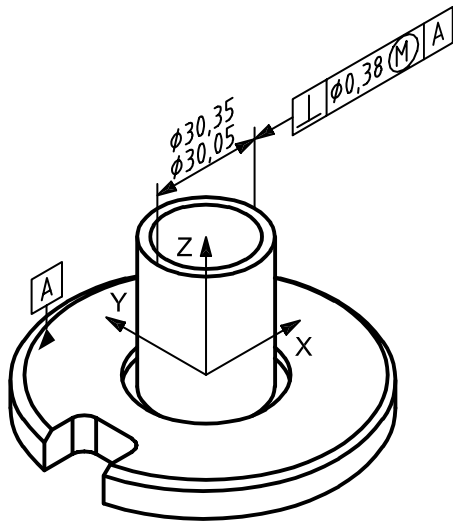

a) Cylinder — Size attachment

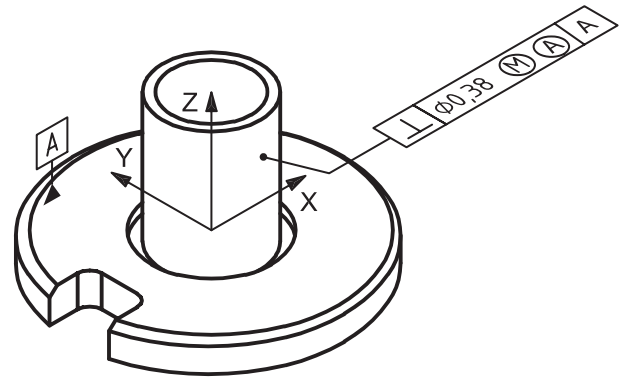

b) Cylinder — Leader attachment

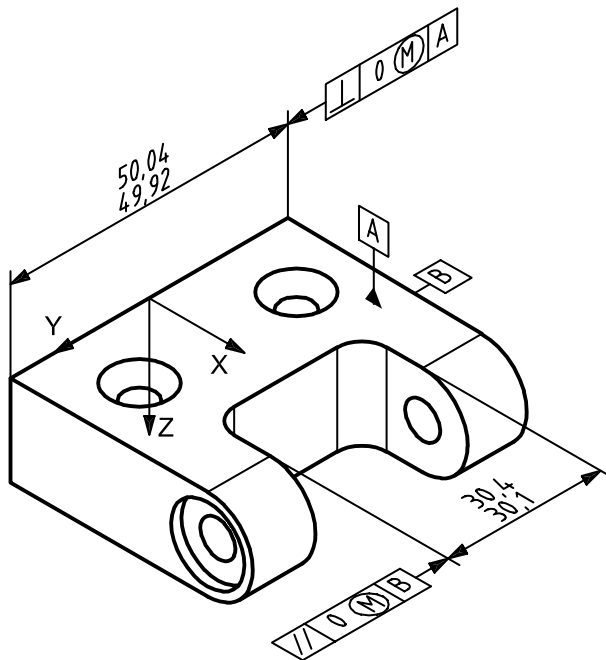

c) Width — Size attachment

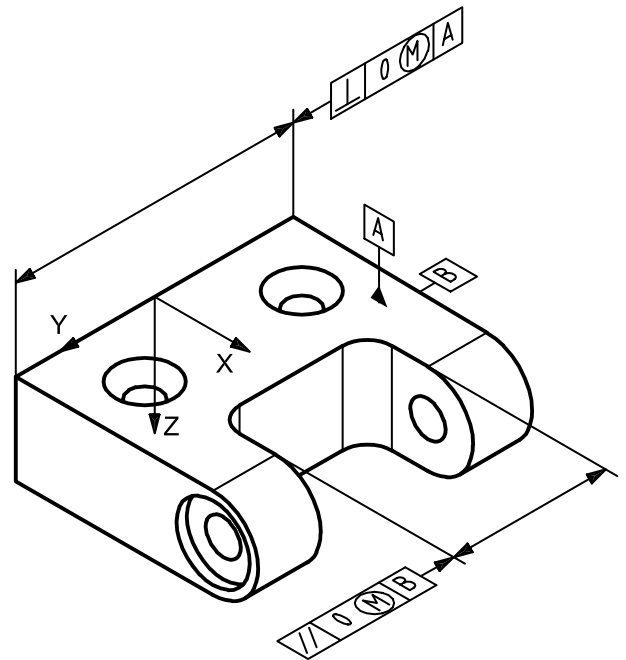

d) Width — Dimension lines attachment

Figure 50 — Orientation — Cylinder or set of opposed parallel surfaces

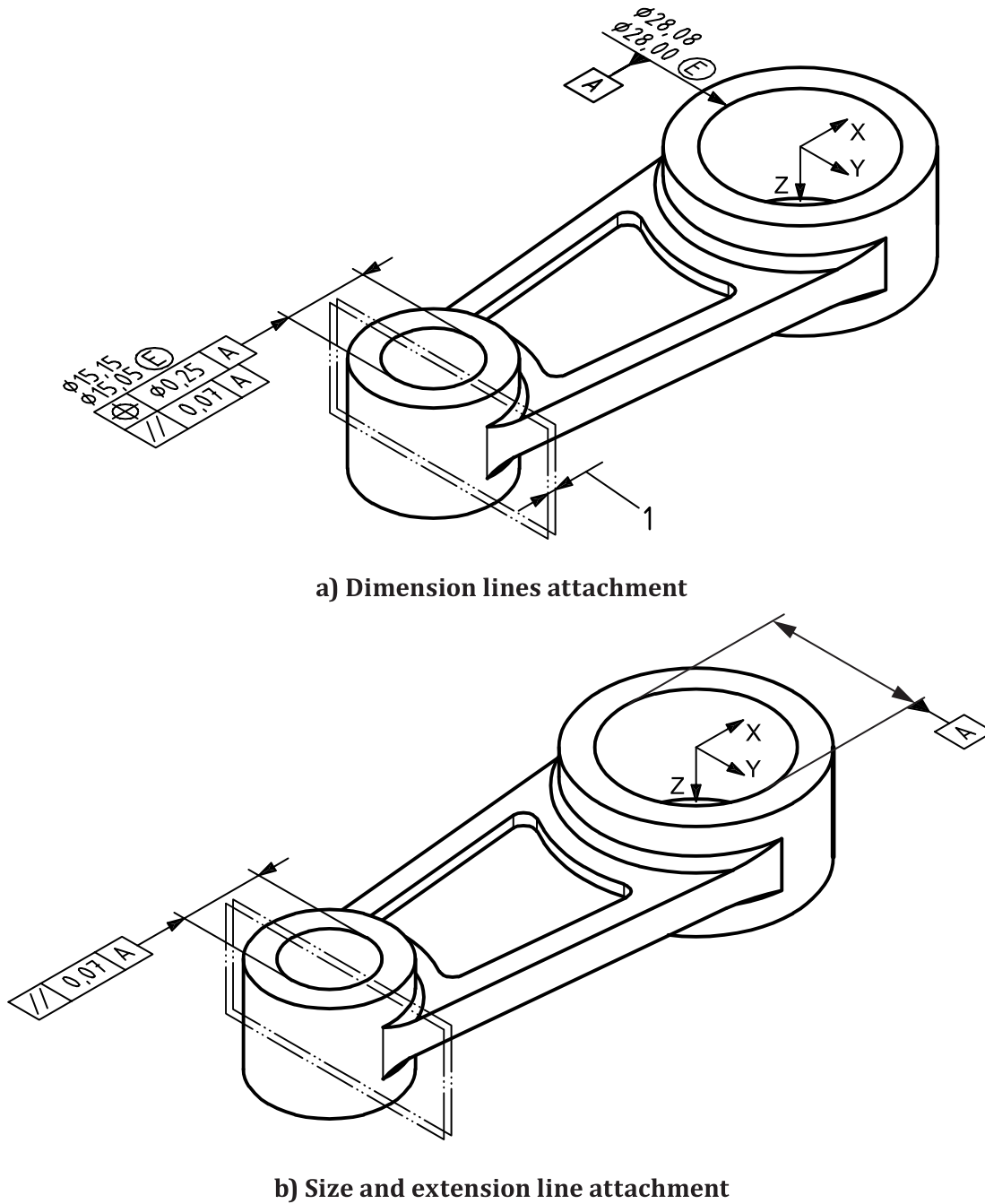

Key

1 parallel plane's tolerance zone (the orientation of direction lines defines the direction of application)

NOTE The tolerance zones shown here are for clarification only and are not part of an actual presentation.

Figure 51 — Orientation of axis with parallel plane's tolerance zone







11.3.4 Profile tolerances

When an individual profile requirement is specified, it shall be attached by a directed leader line using the attachment techniques given in [Table 5](#).

- a) When a tolerance applies to a conical surface or a surface of revolution, the tolerance frame shall be placed on an annotation plane perpendicular to, or containing, the model feature axis [see [Figure 52 b](#)].

- b) When a profile tolerance applies to multiple co-planar surfaces, the model features shall be combined into an associated group. The tolerance frame shall be placed on an annotation plane parallel with, or perpendicular to, the referenced primary datum (see [Figure 53](#)).
- c) When the associated geometry is not sufficient to indicate the application, labelled supplemental geometry may be added to indicate the boundary of application. The between symbol may be used to clarify the requirement (see [Figure 54](#)).
- d) When the *all-around* symbol is used, query shall be used to identify the controlled surfaces (see [Figure 55](#)).
- e) When a profile of a line is directed by a line element, the tolerance frame shall be placed on an annotation plane containing the represented line element parallel with and perpendicular to the absolute coordinate system or an established user-defined coordinate system (see [Figure 56](#)).
- f) When a profile of a line is directed by ordinate axis, the tolerance frame shall be placed on an annotation plane parallel with, and perpendicular to, the absolute coordinate system or an established user-defined coordinate system (see [Figure 57](#)).

Table 5 — Profile tolerances

General application		Attachment technique Directed leader line	Figure
	Planar surfaces	X	52
	Conical surface	X	52
	Revolved surface		
	Multiple or co-planar surfaces	X	53
	Between basis	X	54
	All-around basis	X	55
	Lines in surfaces	X	56
			57

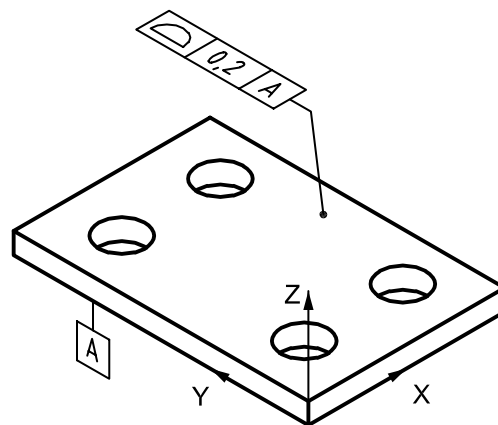

a) Planar surface

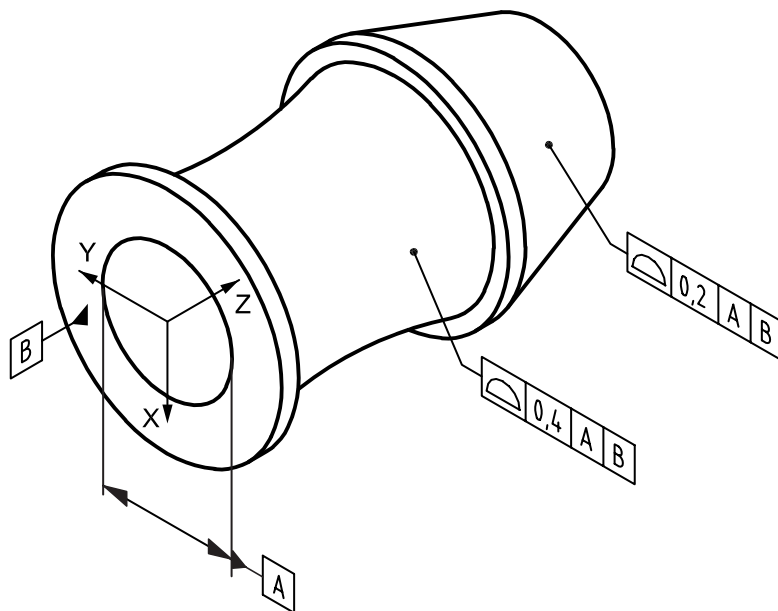

b) Conical or revolved surface

Figure 52 — Profile — Planar, conical, or revolved surface

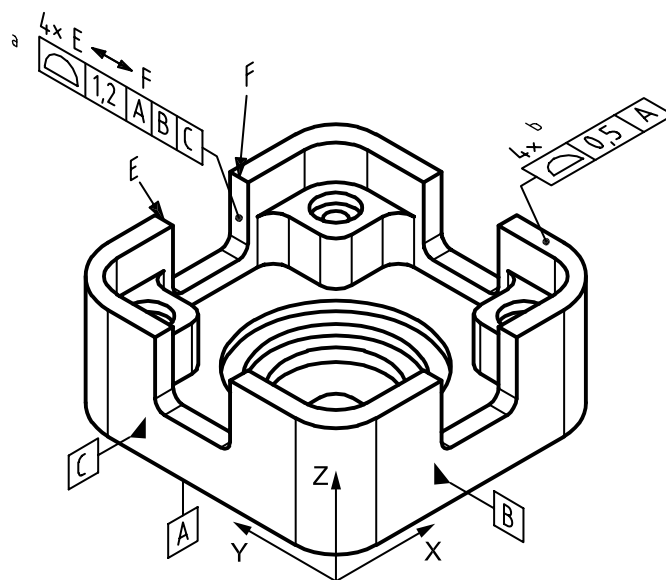

a) Placement and attachment

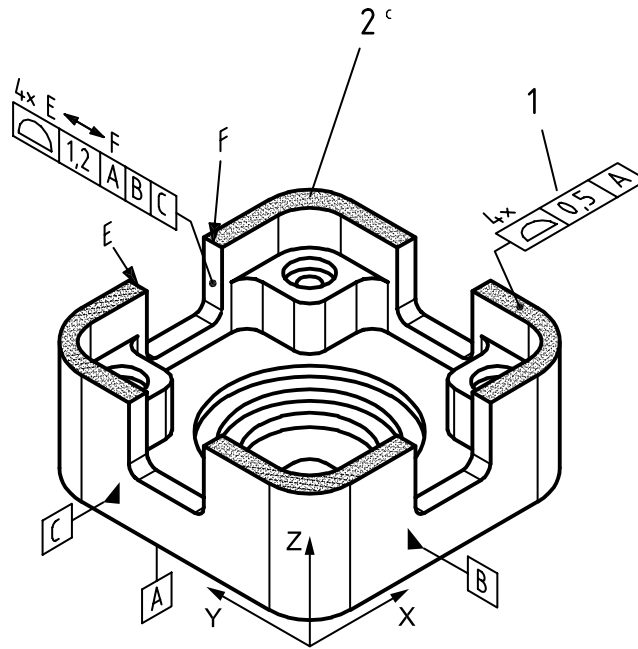

b) Co-planar representation

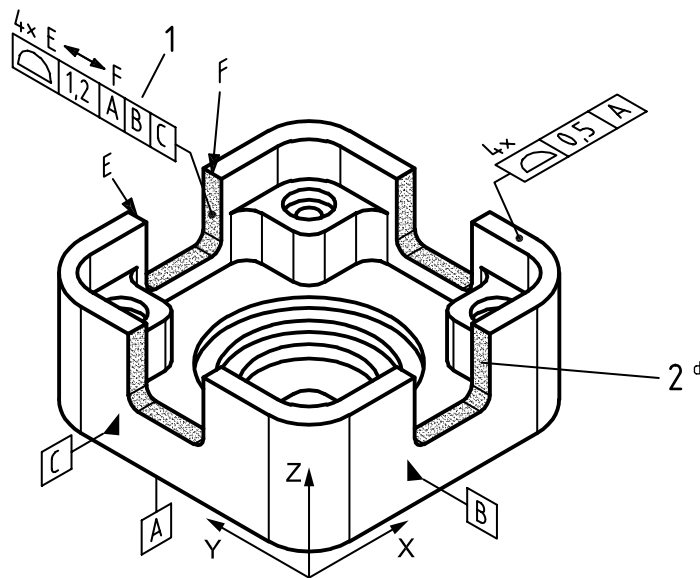

c) Recesses associativity

Key

- 1 Query
- 2 visual response
- a Multiple surfaces.
- b Co-planar surfaces.
- c All four coplanar surfaces.
- d All four recesses.

Figure 53 — Profile — Multiple or co-planar surfaces

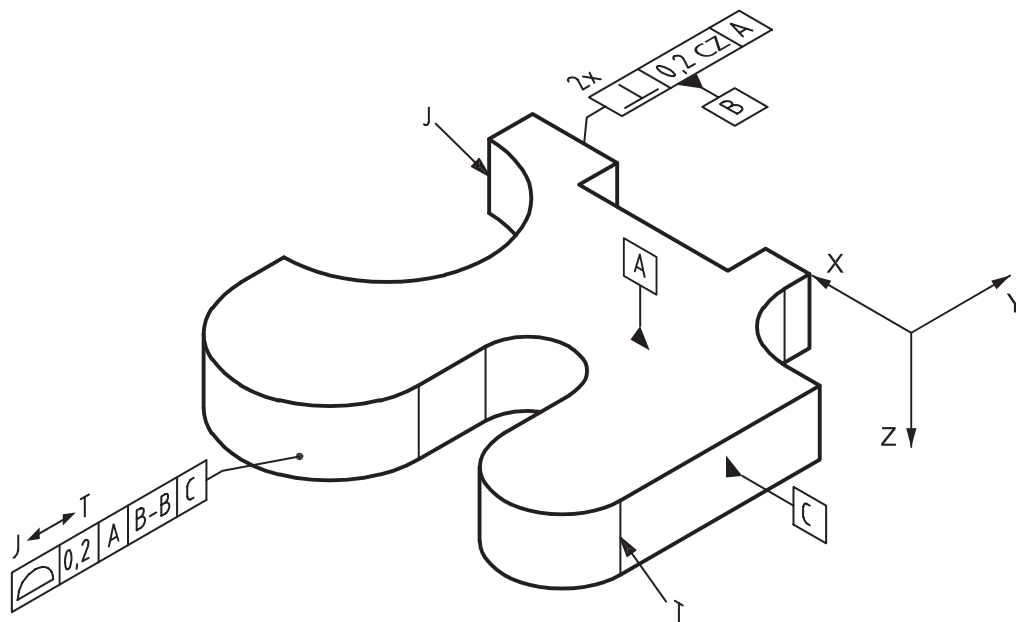

a) Placement and attachment

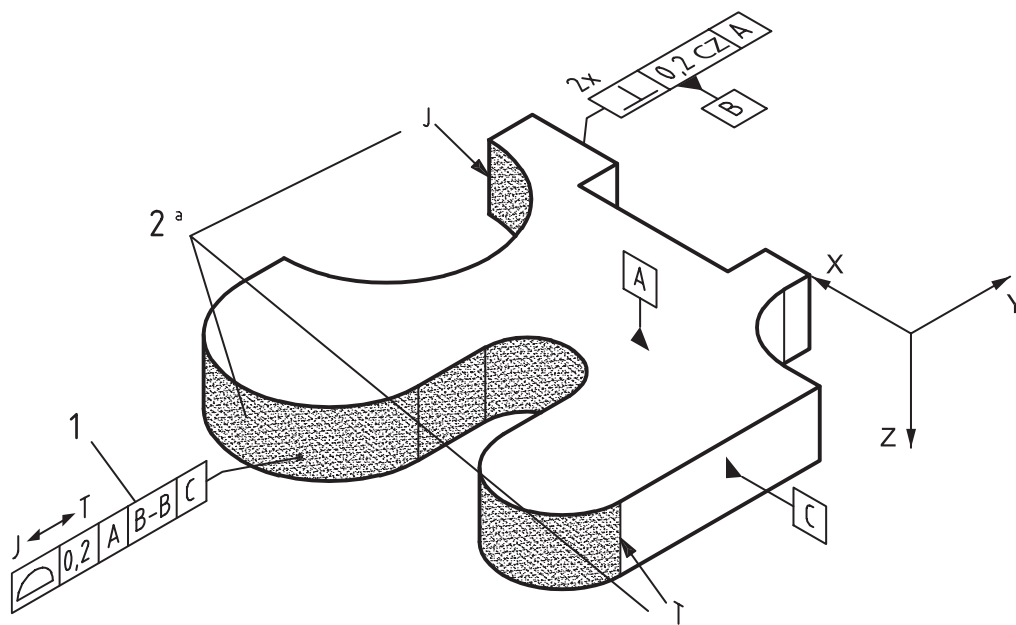

b) Tolerance associativity

Key

- 1 query
- 2 visual response
- a All surfaces residing between lines J and T.

Figure 54 — Profile — Between basis

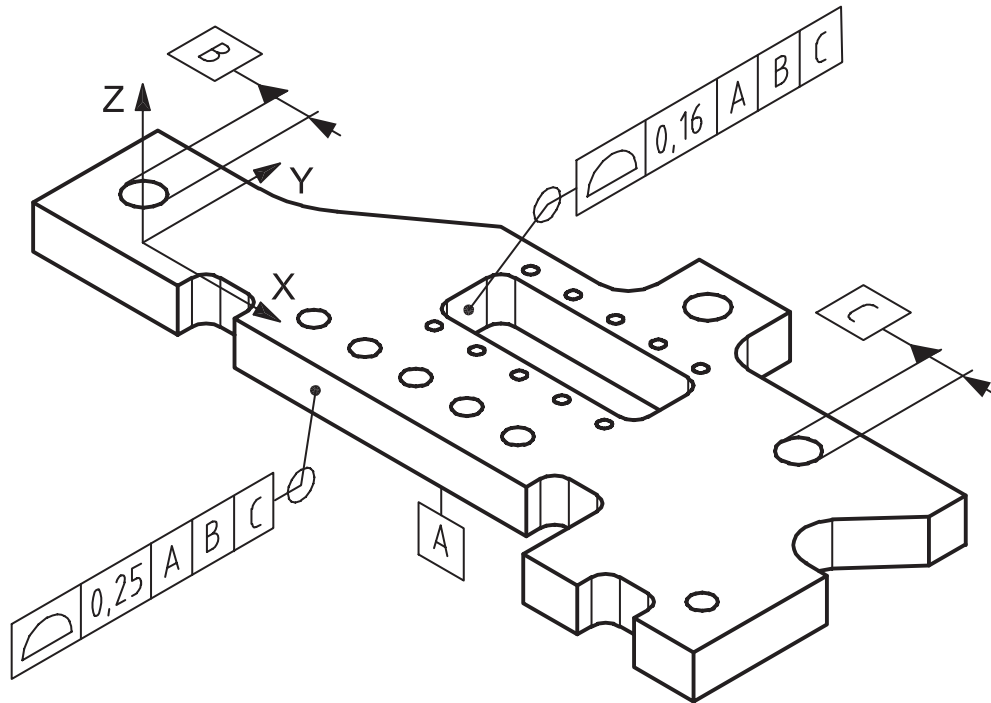

a) Placement and attachment

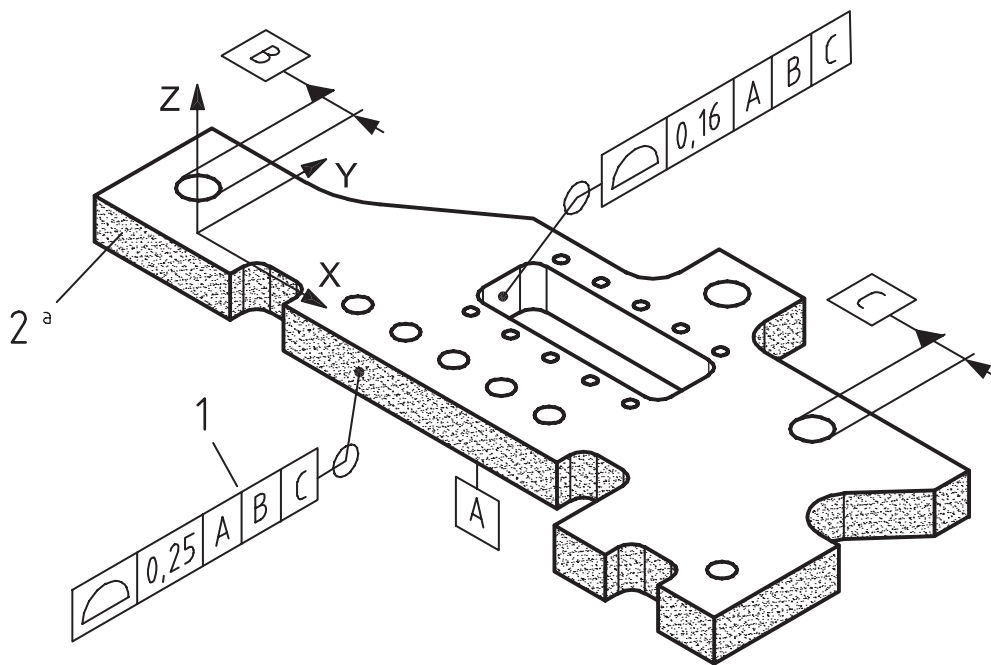

b) Tolerance associativity

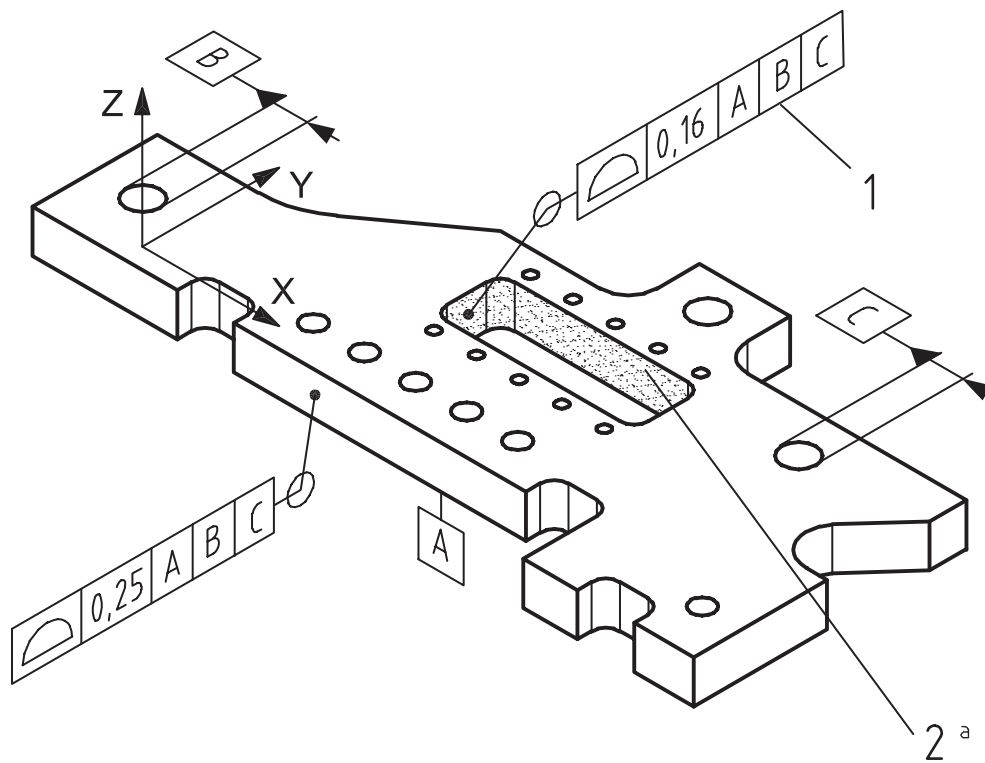

c) Tolerance associativity

Key

- 1 query
- 2 visual response
- a All contiguous surfaces in the closed path.

Figure 55 — Profile — All-around application

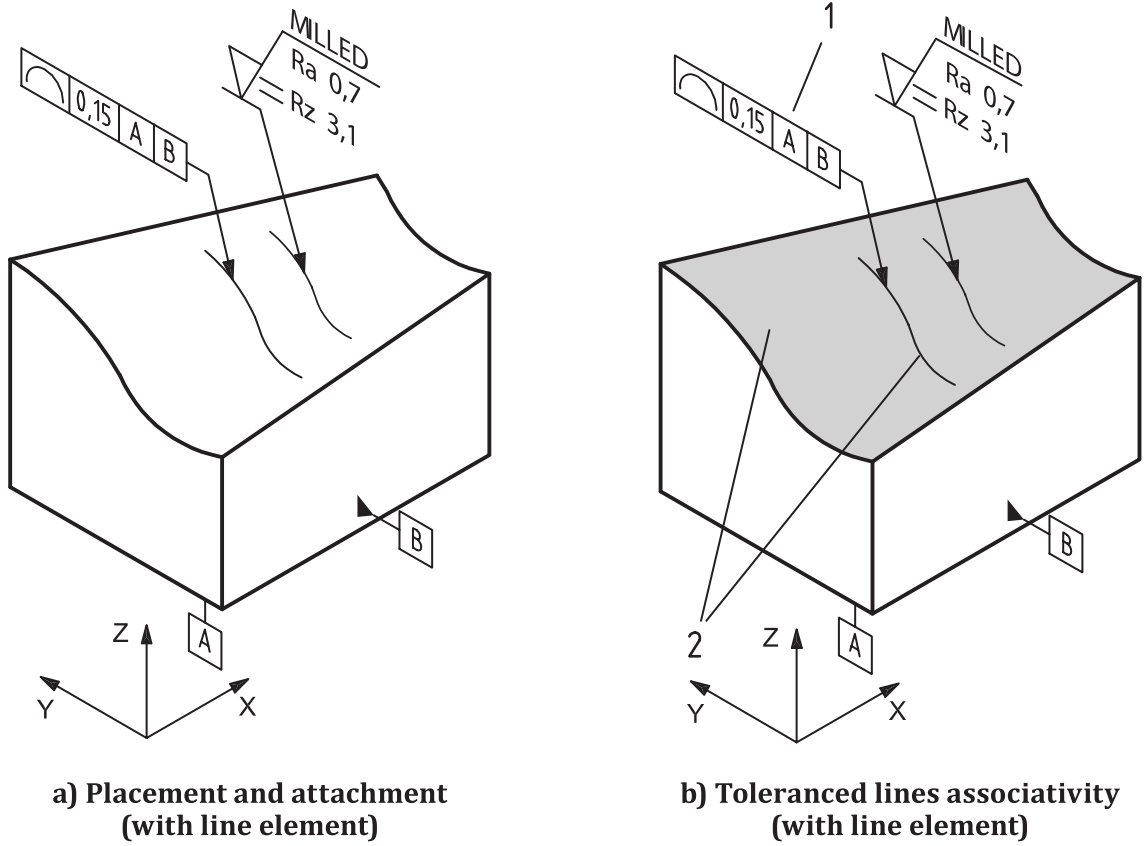

Key

- 1 query
- 2 visual response

Figure 56 — Profile any line — Directed by line element

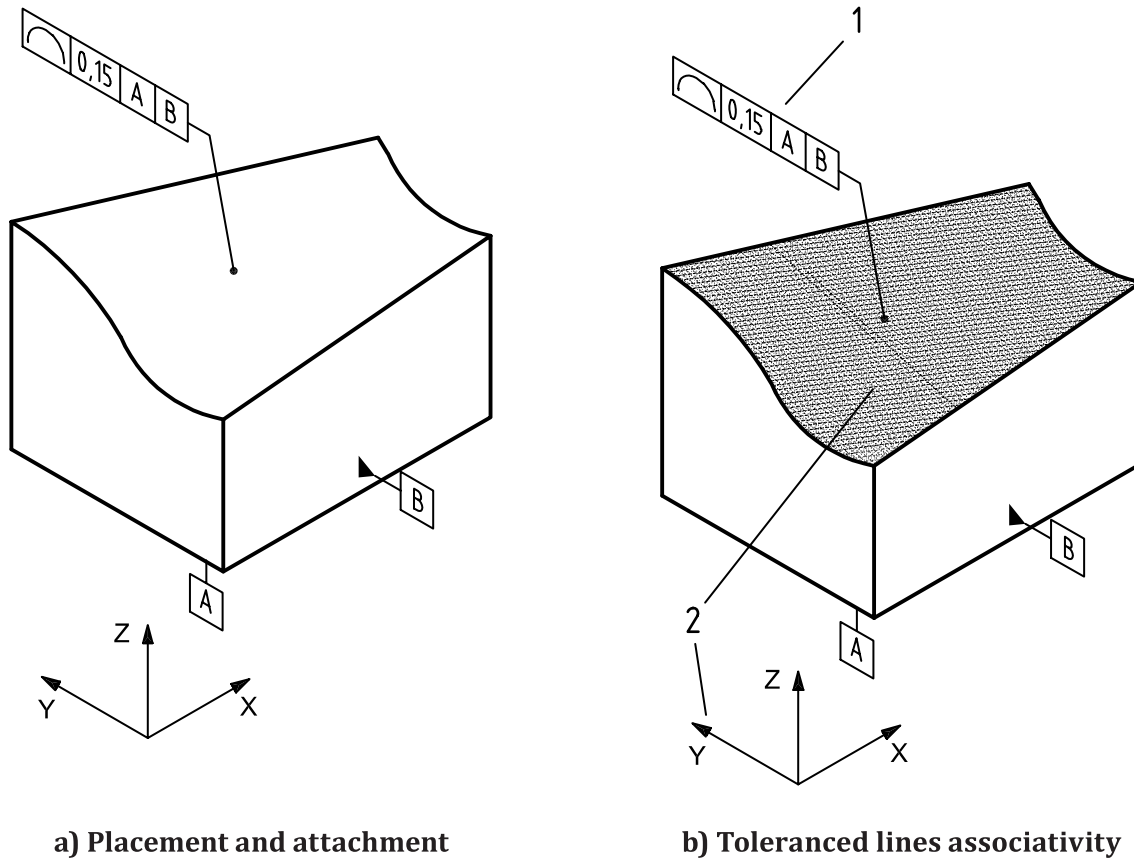

- Key**
- 1 query
 - 2 visual response







Figure 57 — Profile any line — Directed by ordinate axis

11.3.5 Location tolerances

The location tolerance frame shall be placed on an annotation plane parallel with, or perpendicular to, the referenced datum or primary datum, using the location and attachment techniques given in [Table 6](#).

- a) When positioning feature patterns individually to single datums, each individual pattern of model features and the required single datum shall be collected as an associated group. A model coordinate system representing each single datum shall be established (see [Figure 58](#)).
- b) When bi-directional positional tolerancing for polar and rectangular coordinates, the indications specifying the bi-directional requirements shall be placed on the same annotation plane as the size specification for the feature (see [Figure 61](#)).

Table 6 — Location tolerances

General application		Attachment technique			Figure
		Size	Directed leader line	Dimension lines	
	Individually to a single datum	X			58 a)
			X		58 b) , 36
	Projected tolerance zone	X			59 a)
			X		59 b)
	Elongated holes (slots)			X	60
	Bi-directional, polar, or rectangular coordinates			X	61
	Derived median line	X			62 a)
			X		62 b)
	Derived median surface	X			62 c)
				X	62 d)
	Position for a flat integral surface		X		63

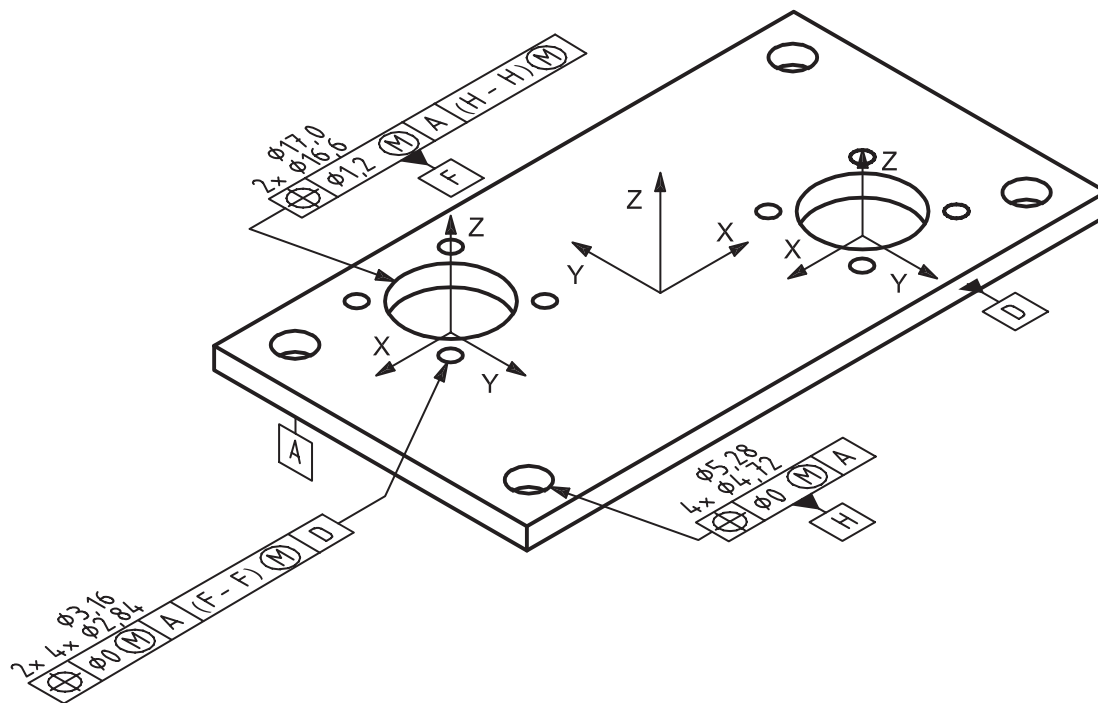

a) Size attachment

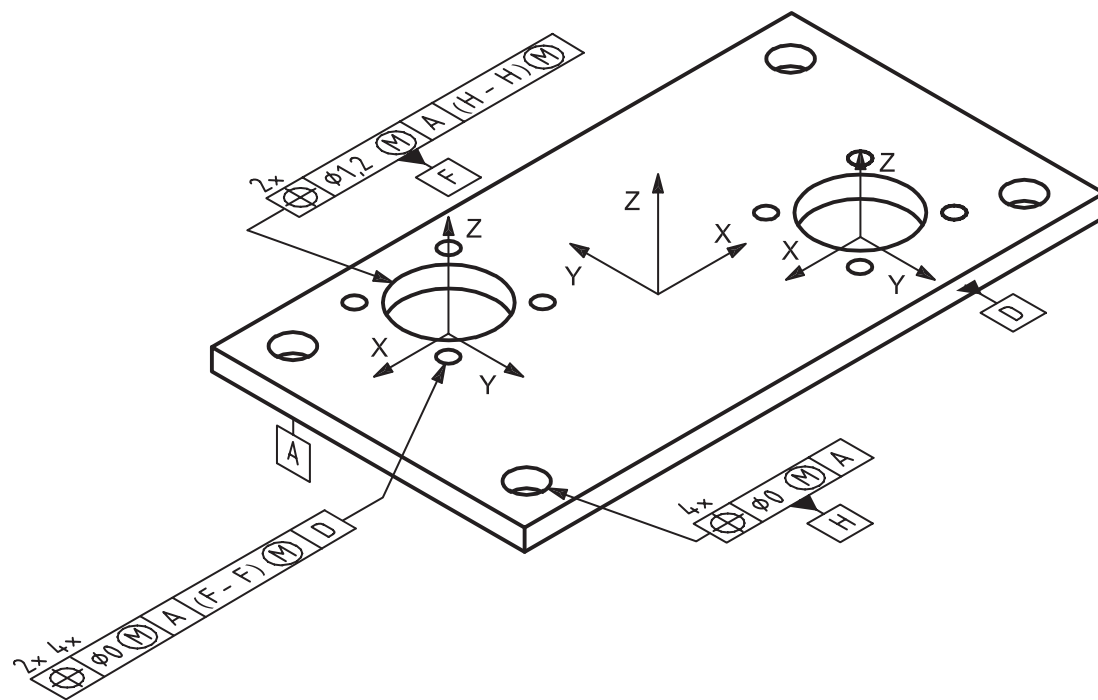

b) Directed leader attachment

Figure 58 — Position — Individual patterns of features

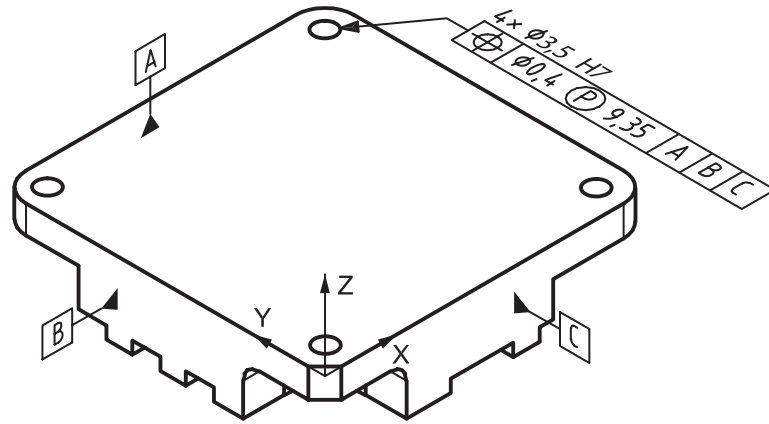

a) Size callout attachment

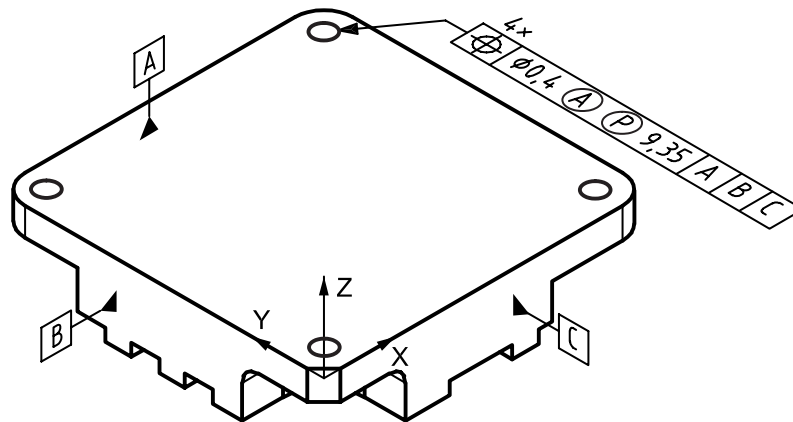

b) Directed leader attachment

Figure 59 — Position — Projected tolerance zones

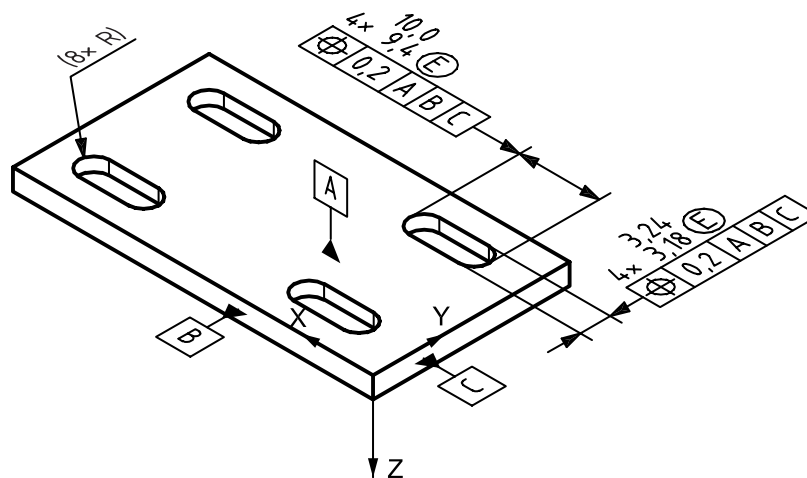
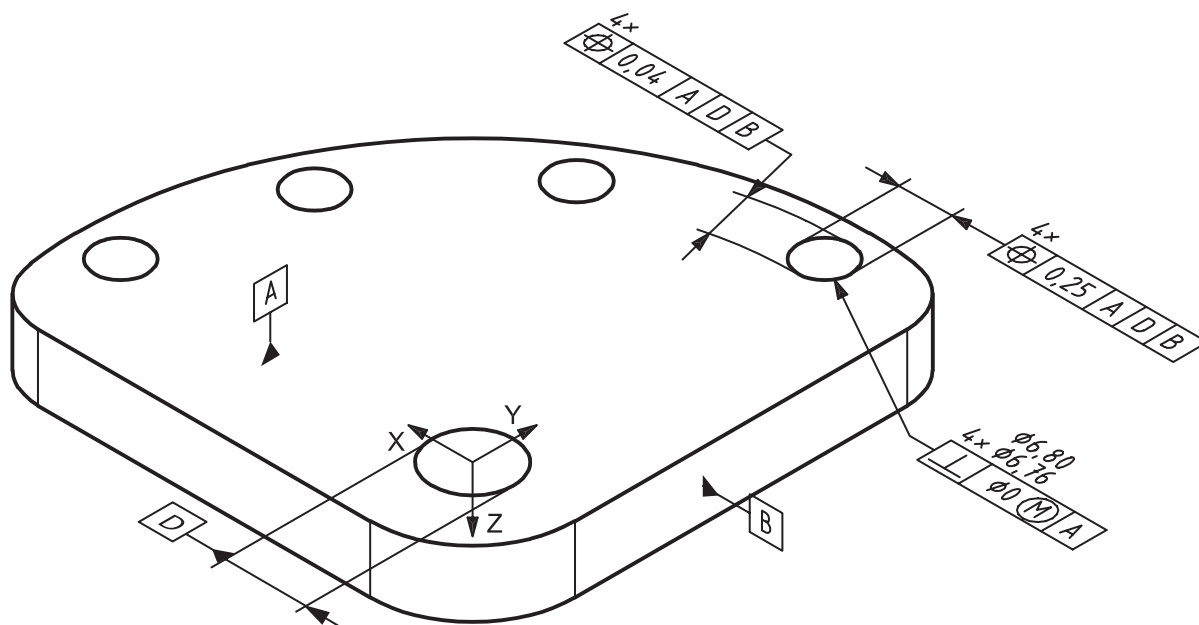
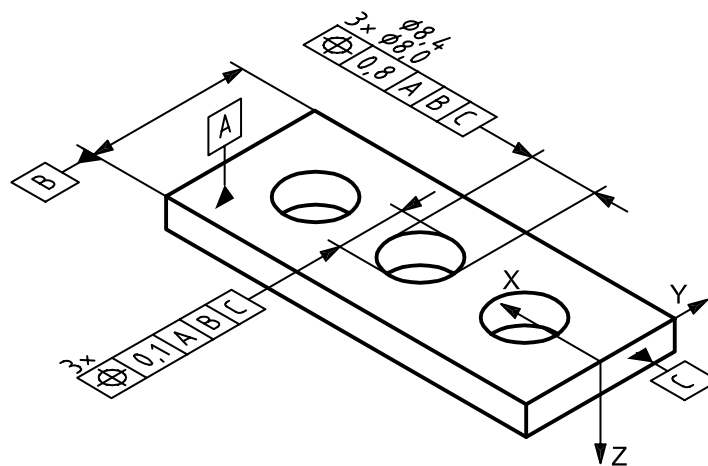

Figure 60 — Position — Elongated holes (slots)



a) Polar coordinate method



b) Rectangular coordinate method

Figure 61 — Bi-directional position — Polar or rectangular

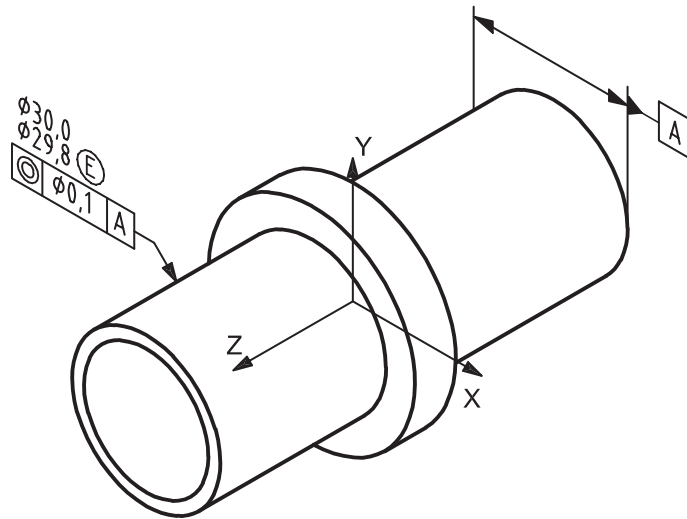

a) Coaxiality — Size attachment

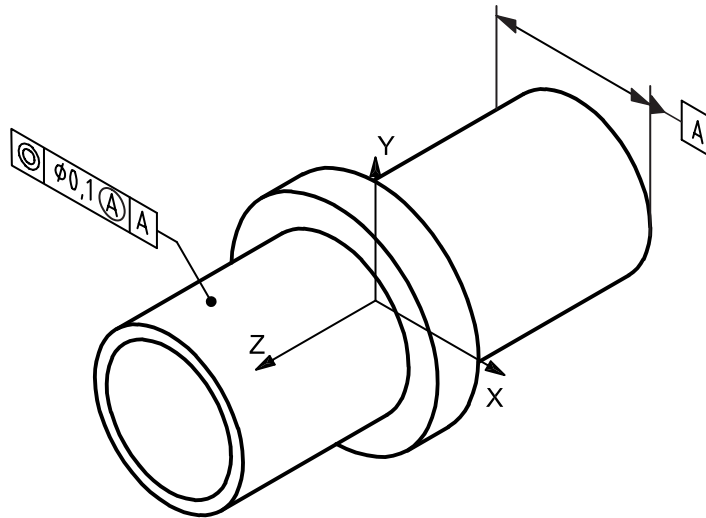

b) Coaxiality — Leader attachment

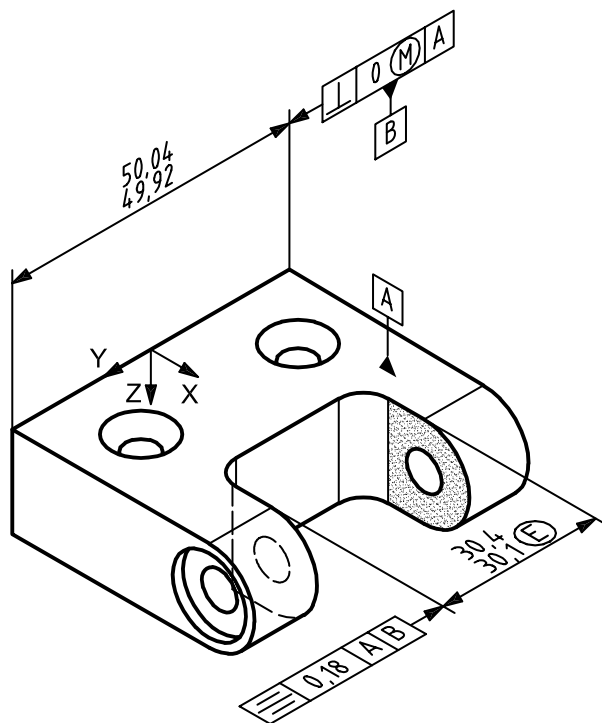

c) Symmetry — Size attachment

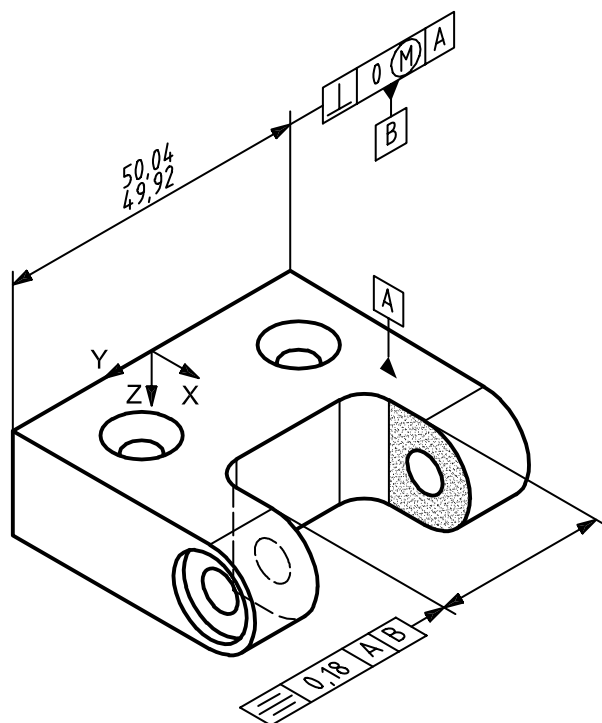

d) Symmetry — Dimension line attachment

Figure 62 — Coaxiality and symmetry

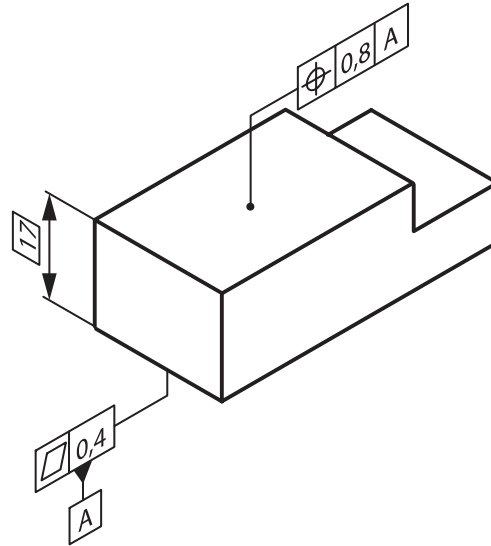

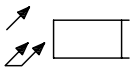
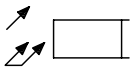
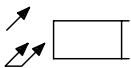

Figure 63 — Position — Flat surface

11.3.6 Runout tolerances

[Table 7](#) specifies runout applications and the attachment method generally used. Applications of circular runout to a spherical, conical, or revolved surface are also given.

- a) The use of multiple leader lines should be avoided when assigning runout tolerances. When the same runout requirement with the same tolerance value and datum reference(s) is applied to multiple features, one of the following methods can be used:
 - 1) Create a single runout tolerance frame for all identically controlled surfaces, and associate it to all applicable model surfaces. A note indicating the number of surfaces to which the tolerance applies may be included for additional associativity emphasis [see [Figures 64 a\)](#) and [b\)](#)];
 - 2) Define the geometric tolerance in a general note;
 - 3) Create and attach a separate runout tolerance frame to each of the toleranced surfaces [see [Figure 64 c\)](#)].
- b) When applying a circular runout to a spherical or conical surface or to a surface of a revolution, the circular runout tolerance frame shall be placed on an annotation plane perpendicular to the conical or revolved surface axis or to one containing the centre point of a sphere (see [Figure 66](#)).
- c) The application of a direction feature indicator is illustrated in [Figure 66 c\)](#).

Table 7 — Runout tolerances

General application		Attachment technique		Figure
		Size	Directed leader line	
	Associatively		X	64
	Surface, perpendicular to a datum axis		X	65 a)
	Cylindrical surface		X	65 b)
			X	65 c)
	Spherical surface	X		66 a)
			X	66 b)
	Conical or revolved surface		X	66 c)

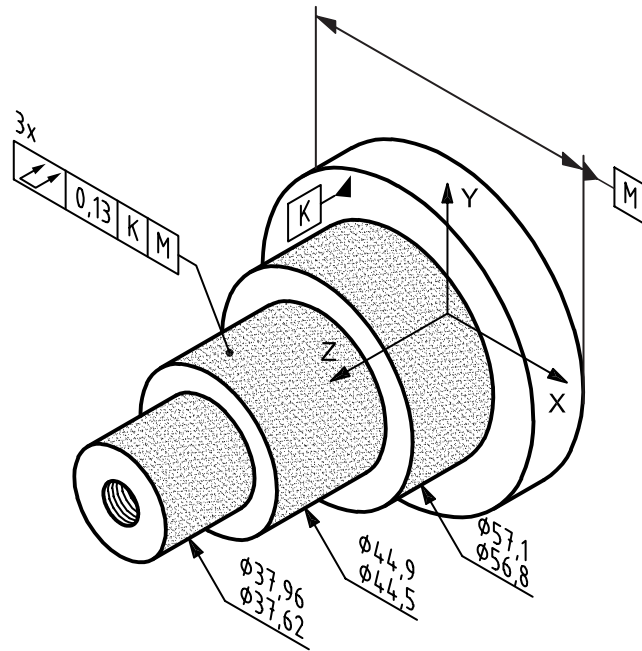

a) Associated features of size

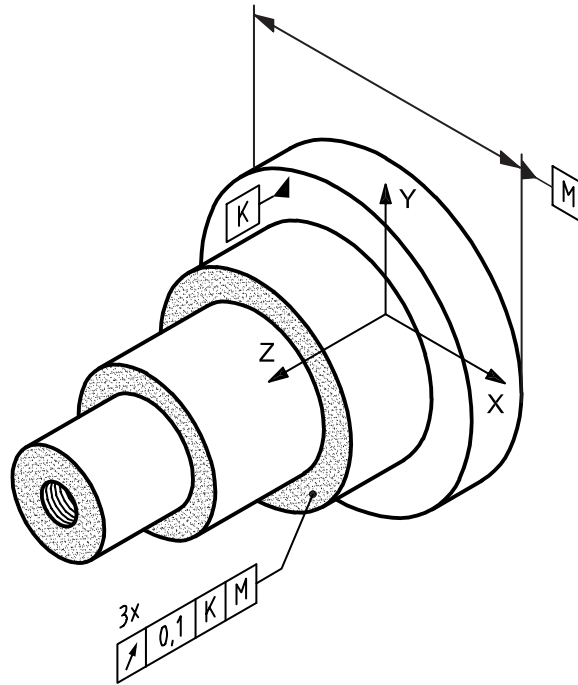

b) Associated surfaces

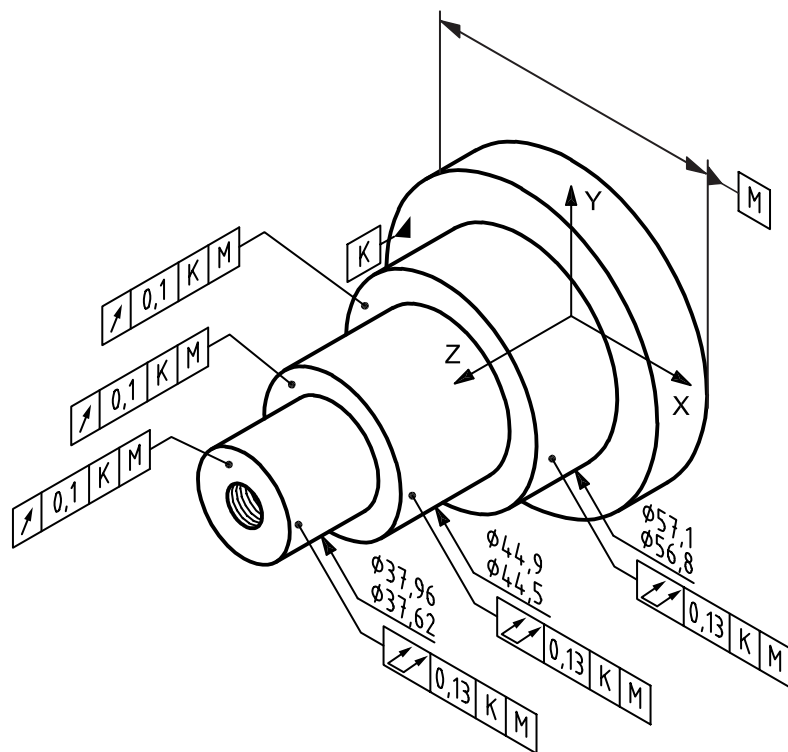

c) Separate runout attachments

Figure 64 — Runout — Attachments and associativity

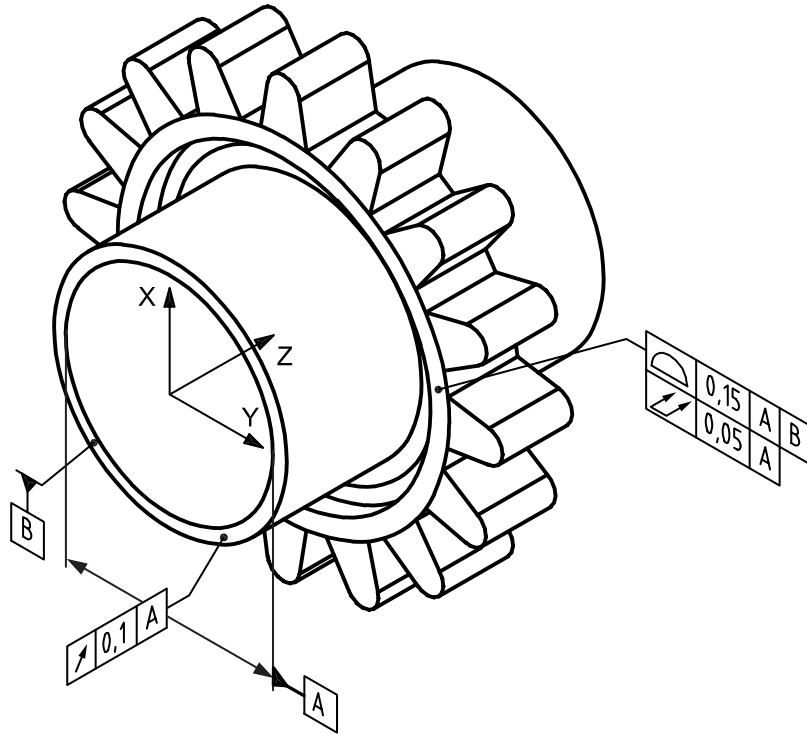

a) Perpendicular surfaces

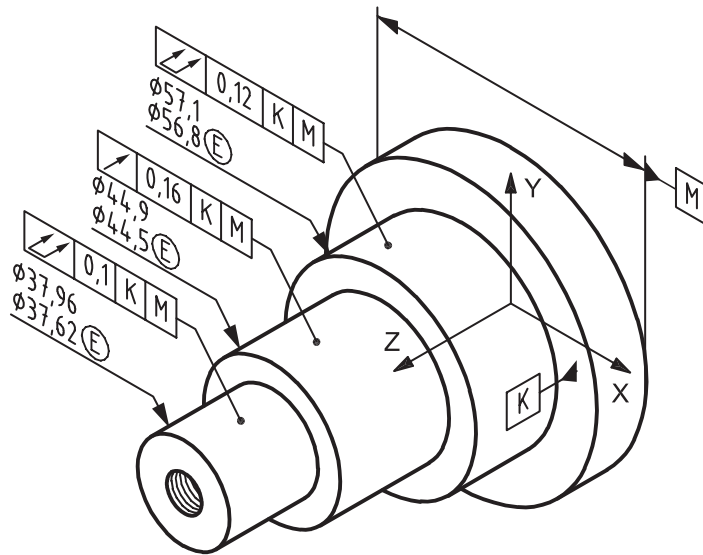

b) Directed leader attachment with size displayed

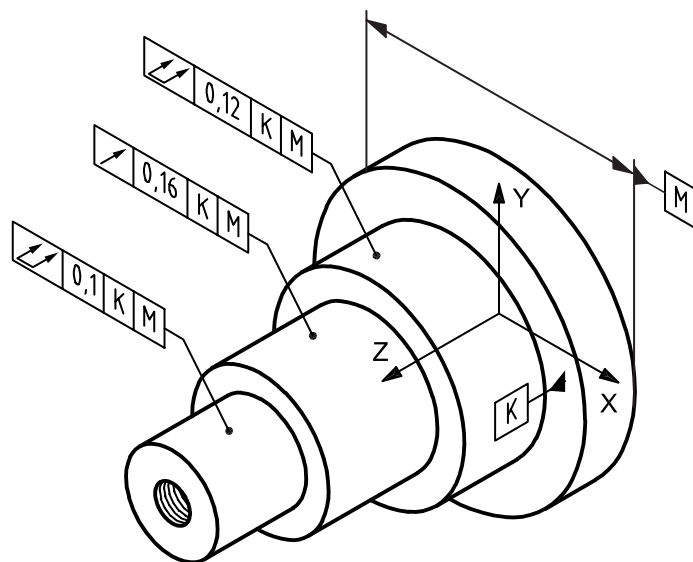

c) Directed leader attachment

Figure 65 — Runout — Perpendicular and cylindrical surfaces

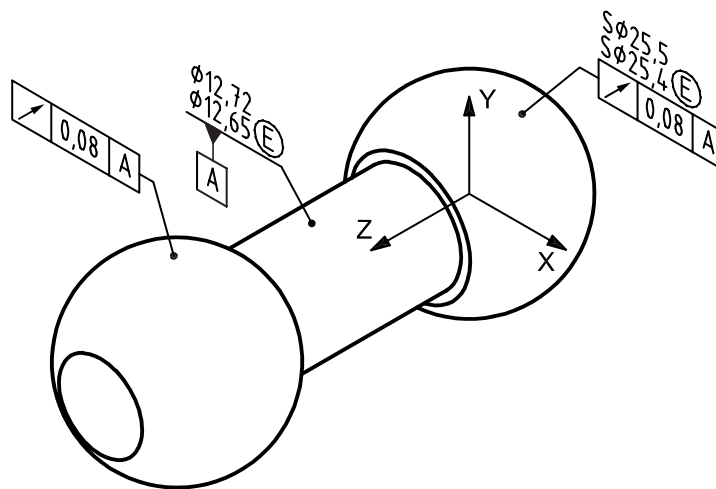

a) Sphere — Size attachment

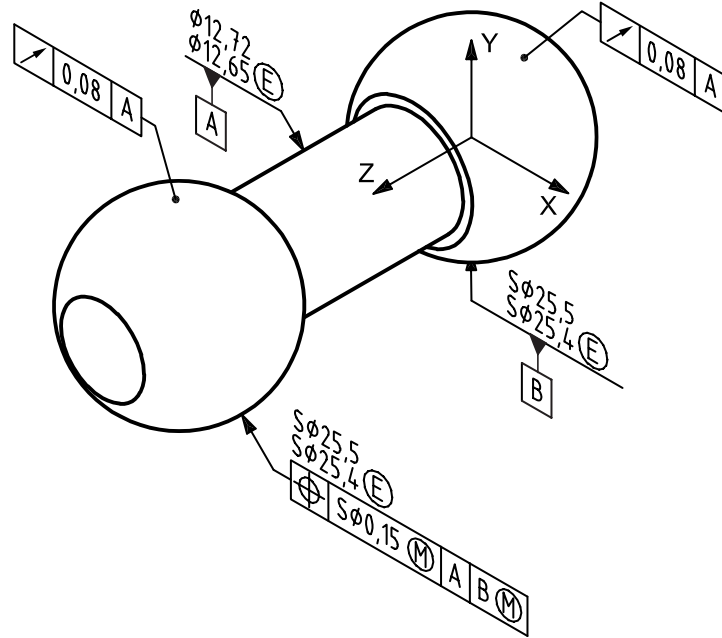

b) Sphere — Leader attachment

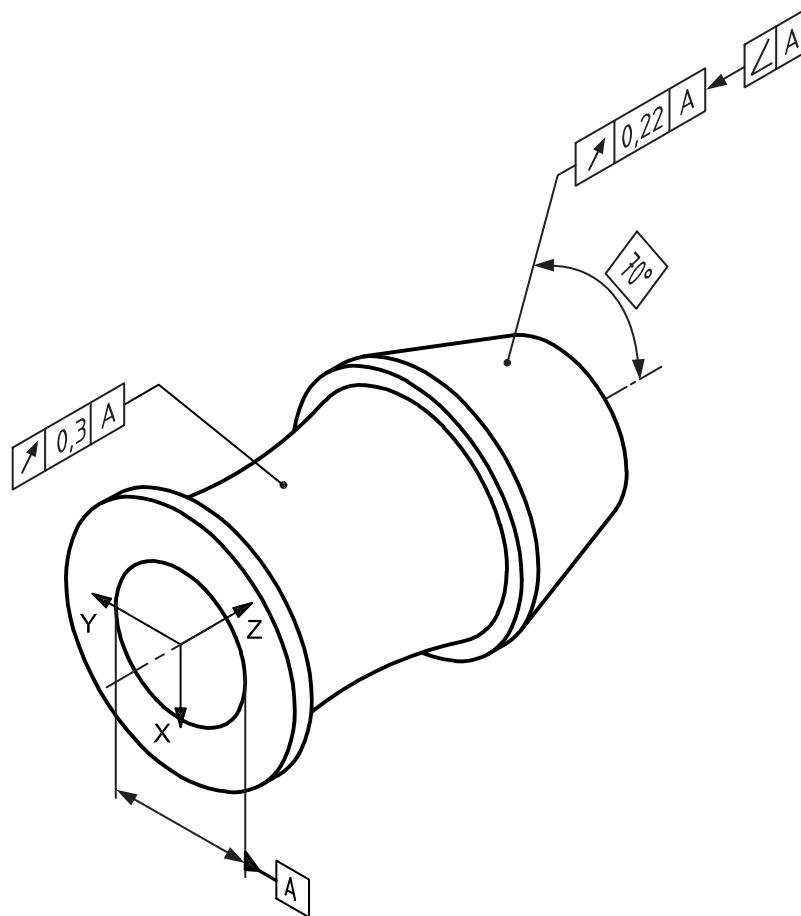

c) Conical surface and surface of revolution — Leader attachment

Figure 66 — Runout — Spherical, conical, or revolved surface

11.4 Drawing requirements

11.4.1 General

11.4.1.1 When using orthographic views, geometric tolerances shall be specified in accordance with ISO 1101, ISO 5459, and other applicable International Standards.

11.4.1.2 When axonometric views are used, the following provides exceptions and additional requirements.

11.4.2 Requirements applicable to all geometric tolerances

11.4.2.1 When tolerancing features on axonometric views, a portion of the tolerated feature shall be visible in the view in which the tolerance is applied.

11.4.2.2 When a geometric tolerance is applied to a feature of size, the tolerance frame shall be placed below the size value [see [Figure 67 a](#)].

11.4.2.3 When a tolerance is applied to a feature surface, the leader line from the tolerance frame shall terminate on the surface with a dot [see [Figure 67 b](#)].

11.4.3 Form tolerances

11.4.3.1 The requirements of [11.4.1](#) apply unless otherwise specified.

11.4.3.2 When a tolerance frame is applied to a restricted area in axonometric views, the restricted area of application shall be represented using supplemental geometry. The leader line directed from the tolerance frame shall be attached within the represented area (see [Figure 68](#)).

11.4.3.3 When a straightness tolerance is applied to the line element of a cylindrical surface using axonometric views, the straightness tolerance frame shall be directed to the cylindrical surface and applies in the direction of the feature axis [see [Figure 69 a](#)].

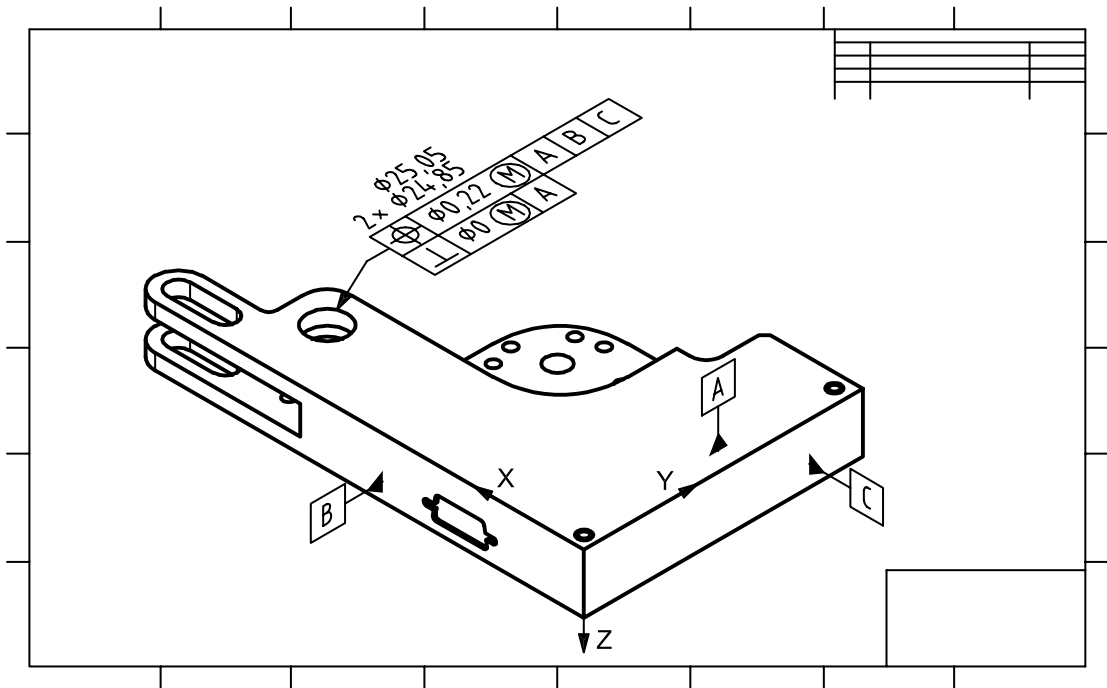

a) Applied to feature of size

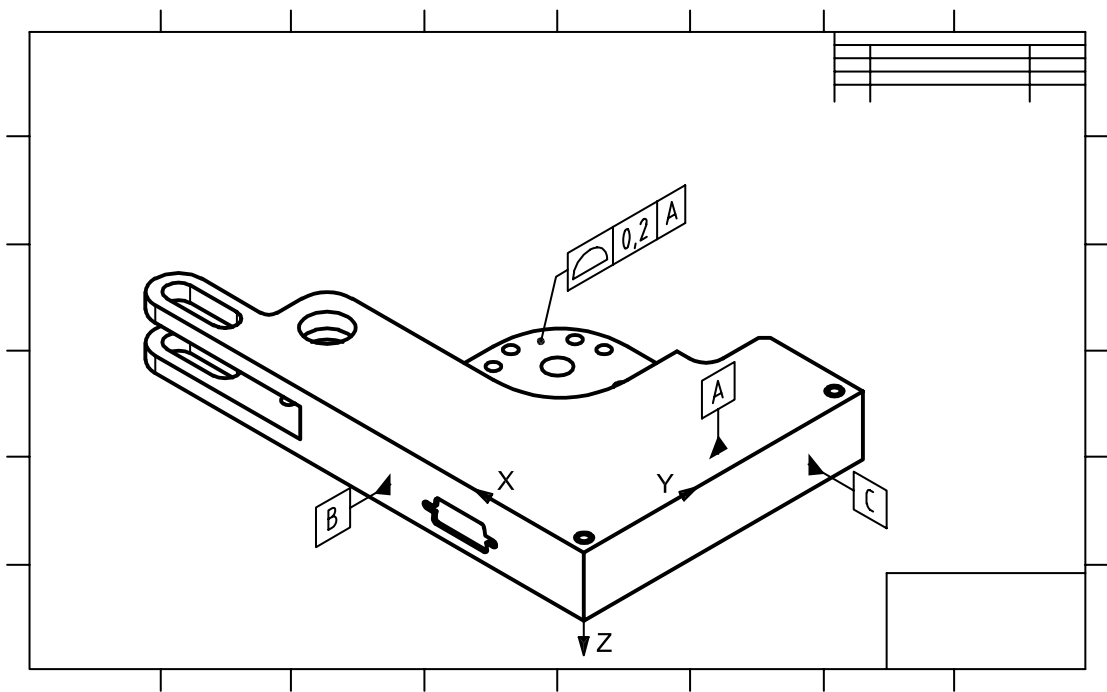

b) Applied to surface

Figure 67 — Axonometric views — Tolerance frames

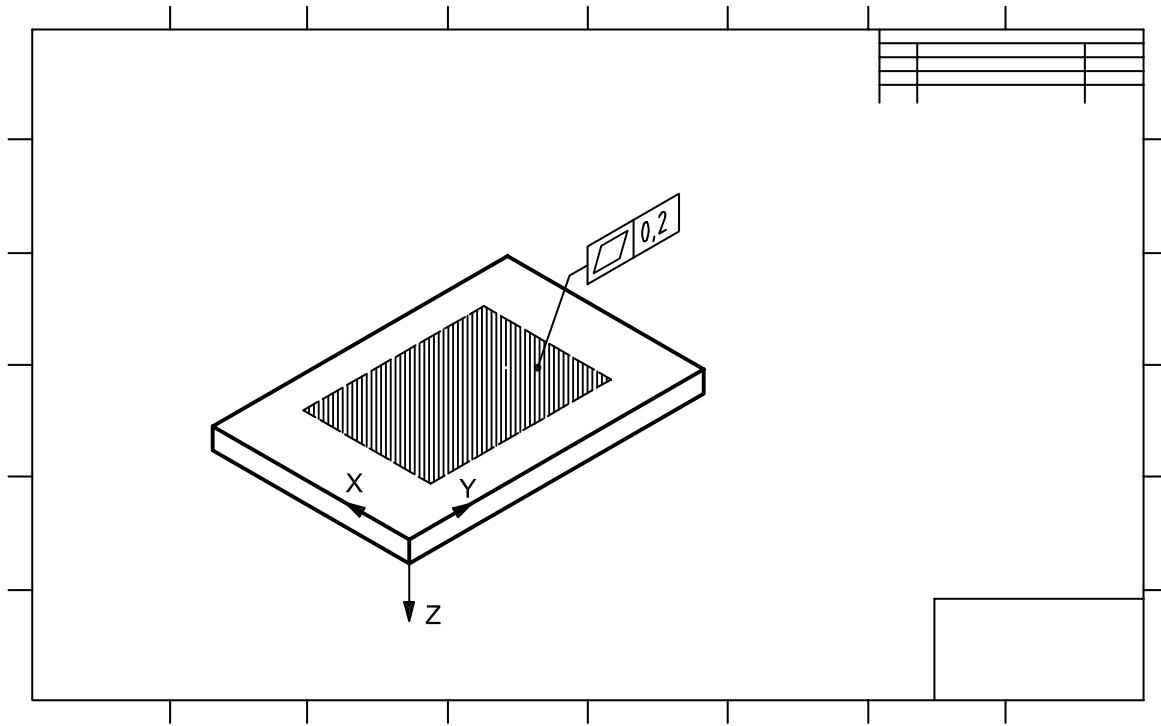
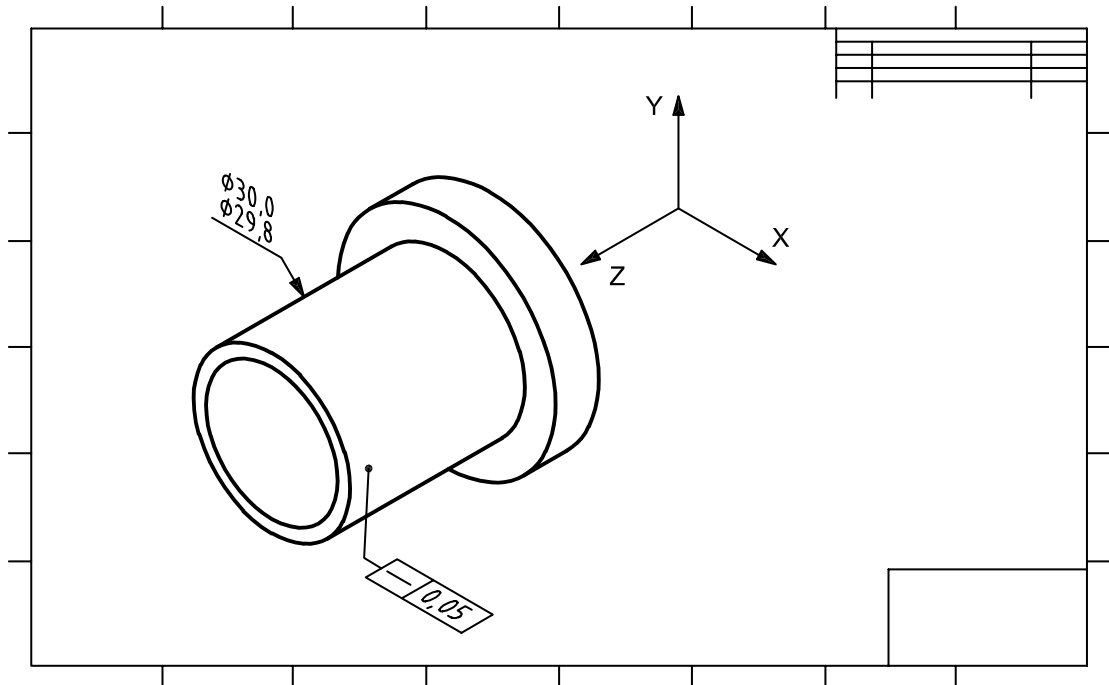
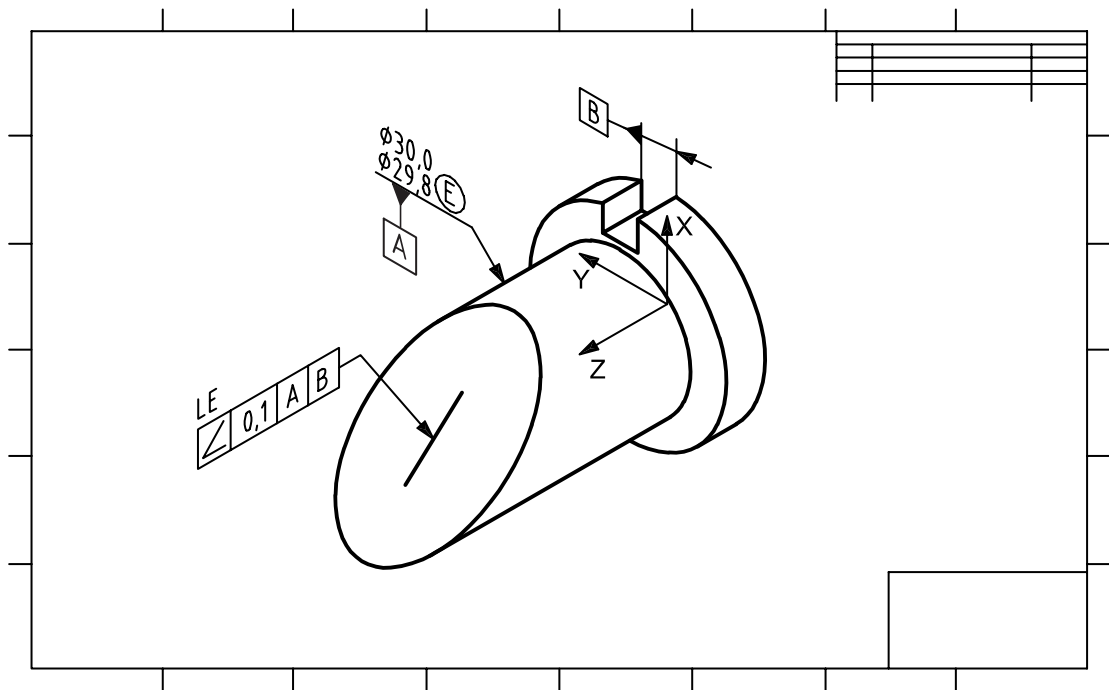

Figure 68 — Axonometric views — Restricted area application



a) Straightness of cylindrical surface



b) Each element orientation

Figure 69 — Axonometric views — Straightness and application of each line element on a surface

11.4.4 Orientation tolerances

11.4.4.1 The requirements of [11.4.1](#) apply unless otherwise specified.

11.4.4.2 When specifying an orientation tolerance for each line element on a surface using axonometric views, the orientation tolerance frame and the notation “LE” shall be directed to the represented line element indicating the direction of application [see [Figure 69 b](#)].

11.4.4.3 When orienting an axis with a parallel planes tolerance zone using axonometric views, the orientation tolerance frame shall be attached to the diametral size and any other geometric tolerance requirement. The orientation of the extension lines defines the orientation of the tolerance zone (see [Figure 70](#)).

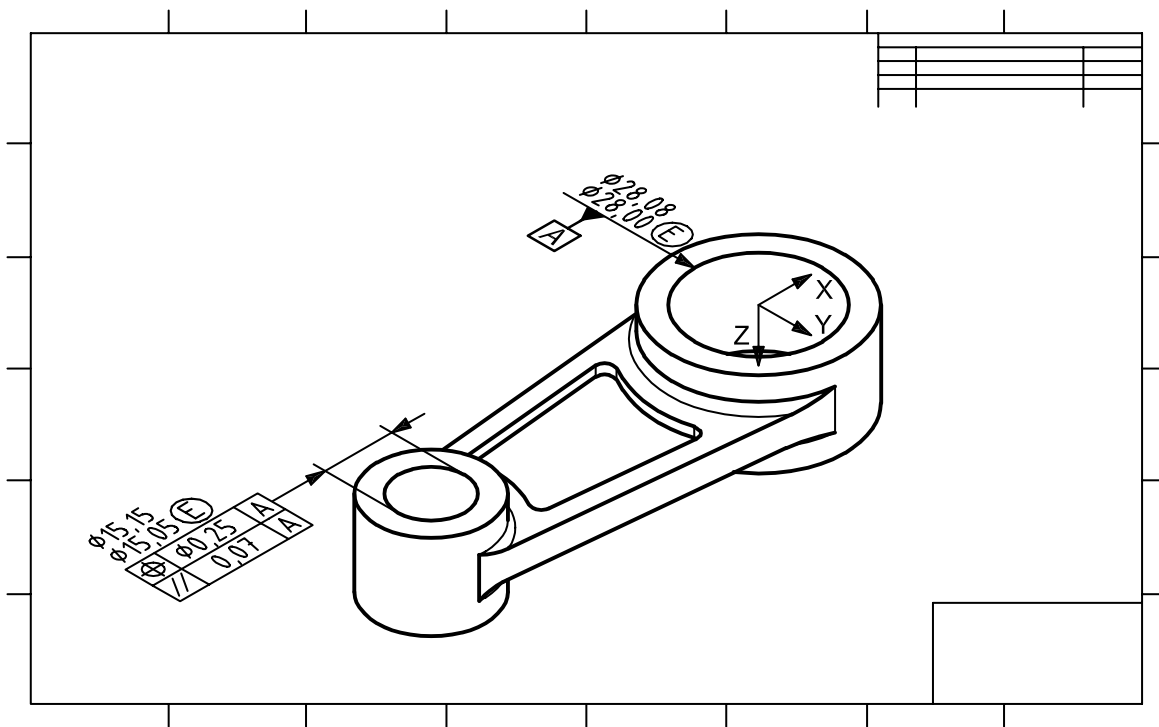

Figure 70 — Axonometric views — Parallel planes tolerance zone

11.4.5 Profile tolerances

11.4.5.1 The requirements described in [11.4.1](#) apply unless otherwise specified.

11.4.5.2 The profile of a surface may be applied to a feature that is not displayed in a profile view.

11.4.5.3 When a profile requirement is specified, it shall be attached using a directed leader line as described in [Table 5](#) for profile applications.

11.4.5.4 When a profile of a surface tolerance is applied to multiple surfaces, it shall be specified using one of the following methods.

- a) The tolerance frame shall be directed to all of the toleranced model features using one or more leader lines.

- b) Using the CZ modifier in the tolerance frame (see ISO 1101), the appropriate model features shall be identified (see [Figure 71](#)).
- c) Using the between symbol (see ISO 1101) and identifying the model features with two lines to indicate the limits of the area of application (see [Figure 72](#)).

11.4.5.5 When the *all around* symbol is used with a profile of a surface, it shall be shown in an orthographic view that contains the nominal or theoretically exact profile of the tolerated features.

11.4.5.6 When a *profile any line* indication is required, it shall be applied to a represented line element showing the direction of application.

11.4.5.7 When a *surface profile* indication is required, it shall be applied using a directed leader line.

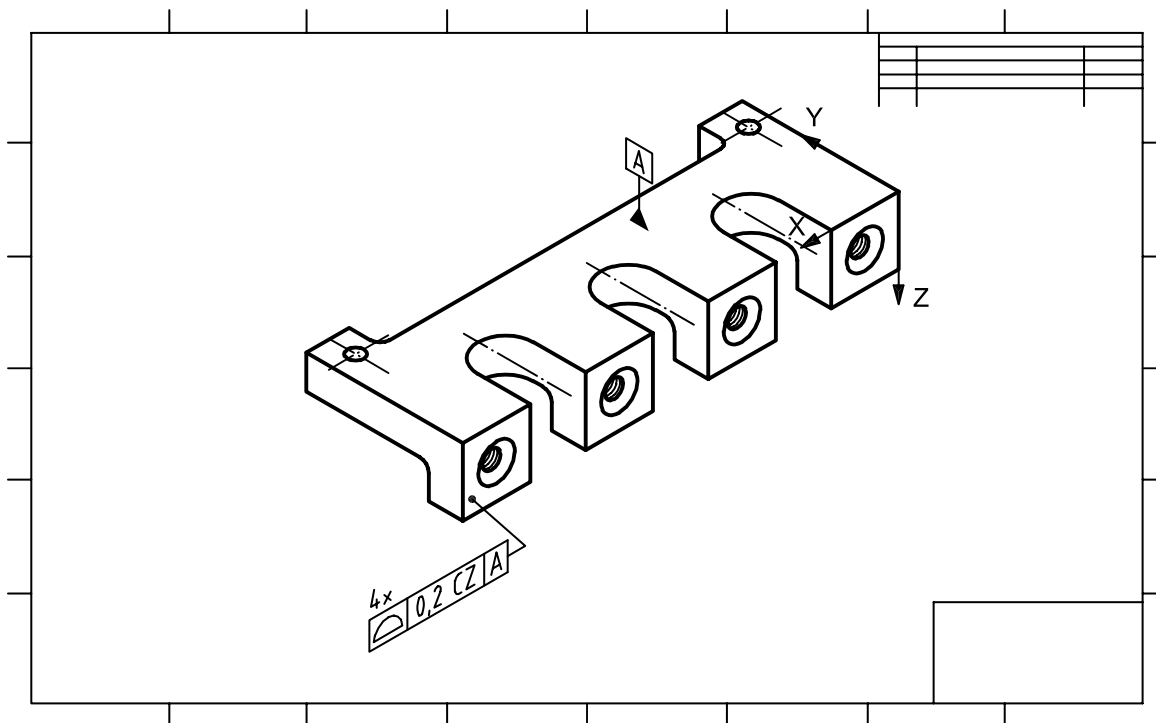

Figure 71 — Axonometric views — Multiple surfaces

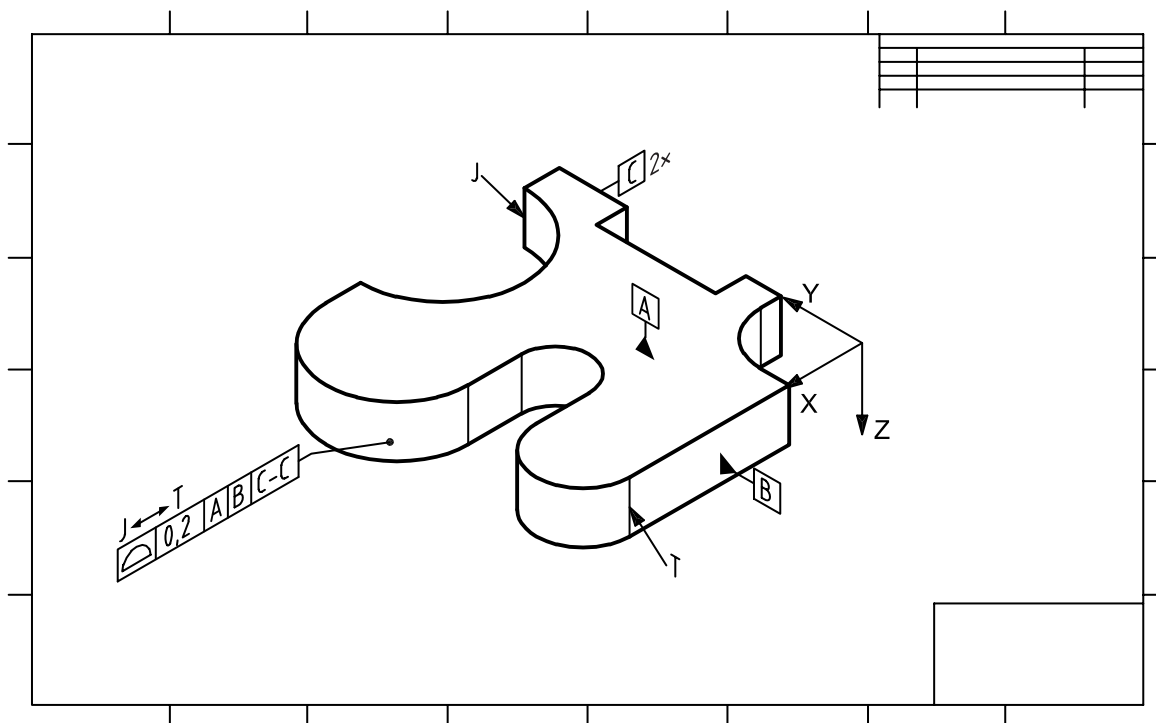

Figure 72 — Axonometric views — Between basis

11.4.6 Position tolerances

The requirements given in [11.4.1](#) apply unless otherwise specified.

11.4.7 Runout tolerances on a drawing

Runout tolerances shall be applied according to [11.4.1](#).

12 Welds

12.1 General

Welding symbols shall be in accordance with ISO 2553. This clause establishes the placement, attachment, and display requirements and other provisions for welds.

12.2 Common requirements

12.2.1 Application of supplemental geometry

Supplemental geometry can be used to indicate the path of the weld.

12.2.2 Arrow lines

Welding symbols are drawn using an arrow line:

- the arrow line shall terminate with an arrowhead;
- the arrow line shall terminate on the joint or on supplemental geometry when a supplemental geometry is used to indicate the path of the weld (see [Figure 73](#)).

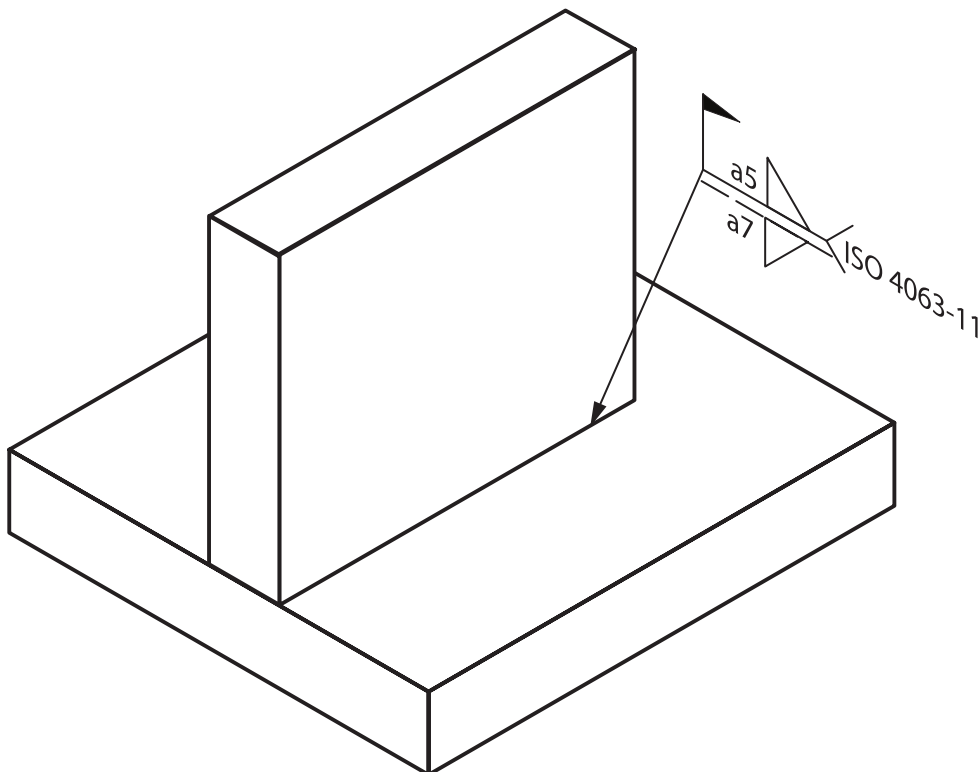

Figure 73 — Placement of a weld

12.3 Model requirements

12.3.1 Annotation plane

The welding symbol shall be placed in an annotation plane that is perpendicular to or is coplanar with the joint or the supplemental geometry indicating the path of the weld [see [Figures 73](#) and [75 b](#)].

12.3.2 Associativity

The portions of the model which are being welded together shall be the associated geometry for the weld.

12.3.3 Indicating extents of the weld

When the associated geometry and the indicated weld path are not sufficient to indicate the area of application, the following techniques may be used as appropriate.

The extent of the weld may be further clarified by defining the extent of the weld or its placement.

When the weld applies to a limited length of the indicated weld path, the extents of the weld may be indicated using the between symbol and the limits of the application labelled as shown in [Figure 74](#).

When the exact location of the weld is to be defined, a dimension may be applied to indicate the start of the weld (see [Figure 75](#)).

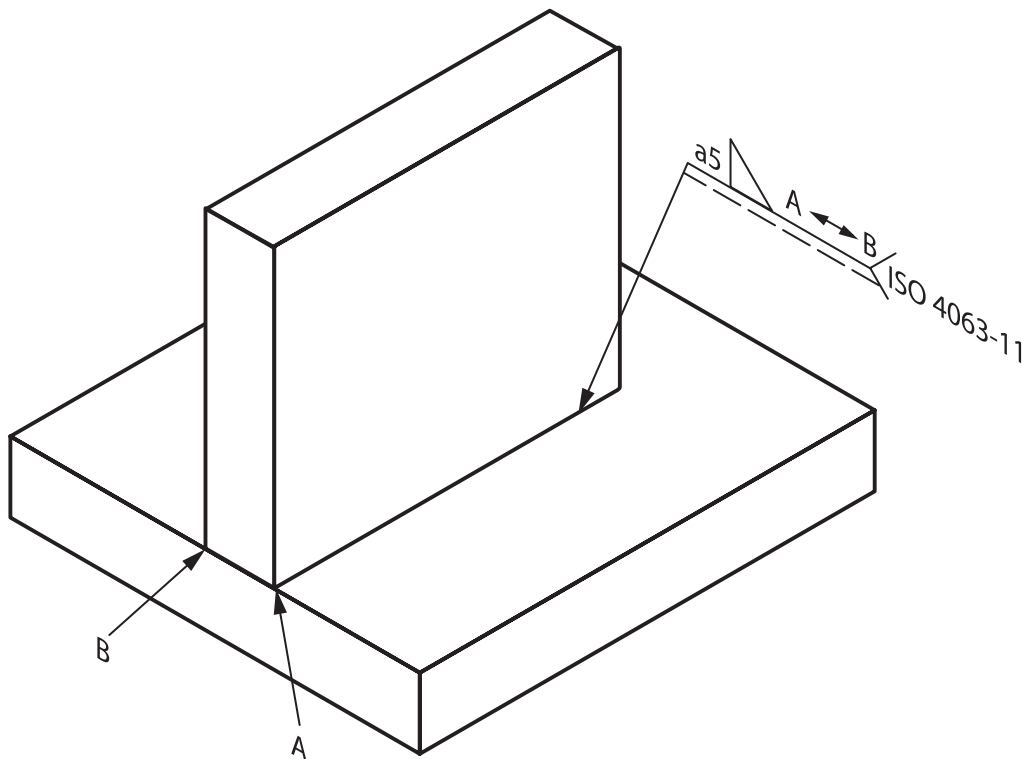
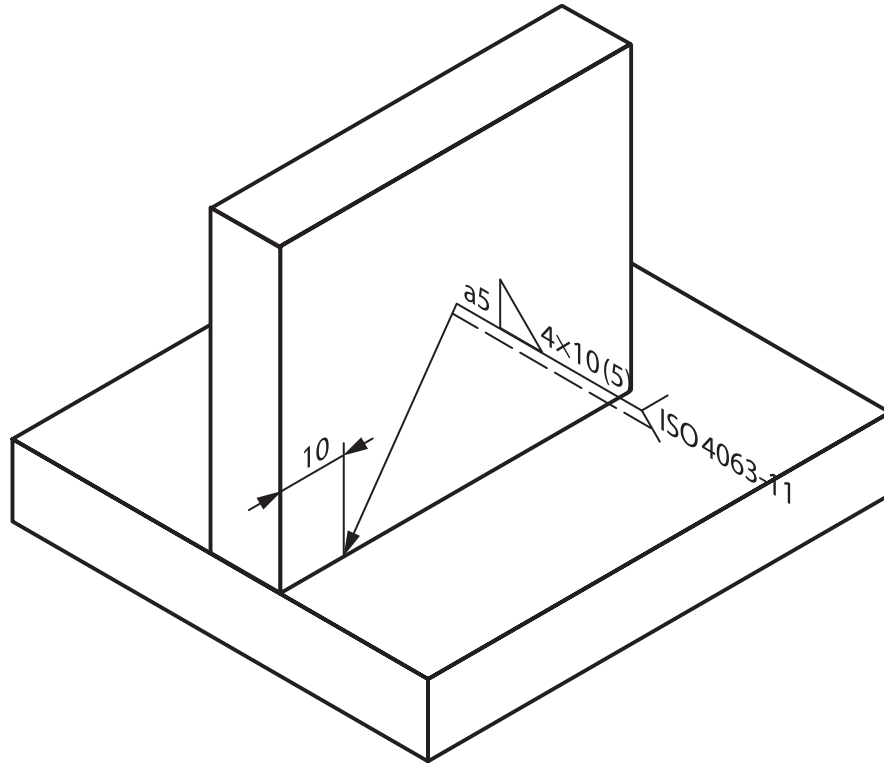
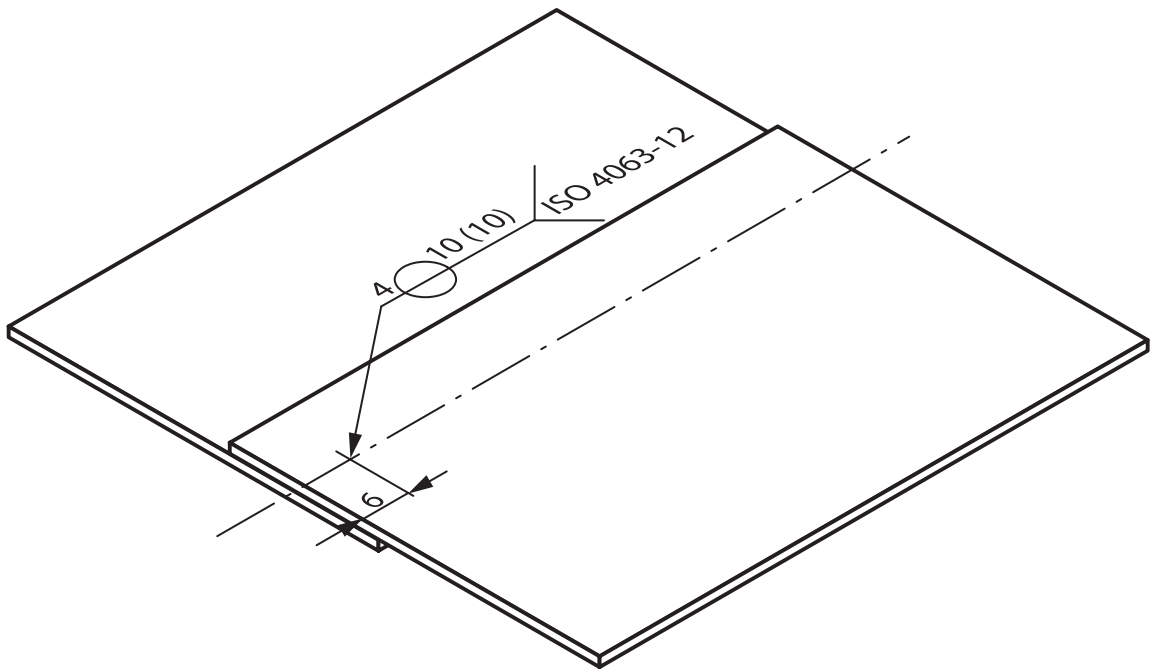

Figure 74 — Extent of a weld using the between symbol



a) Fillet weld



b) Spot welds

Figure 75 — Indication of location of welds

12.3.4 Query of weld path

Upon selection of a weld, the geometry representing the weld path shall be highlighted or otherwise distinguished from other entities on the display (see [Figure 76](#)).

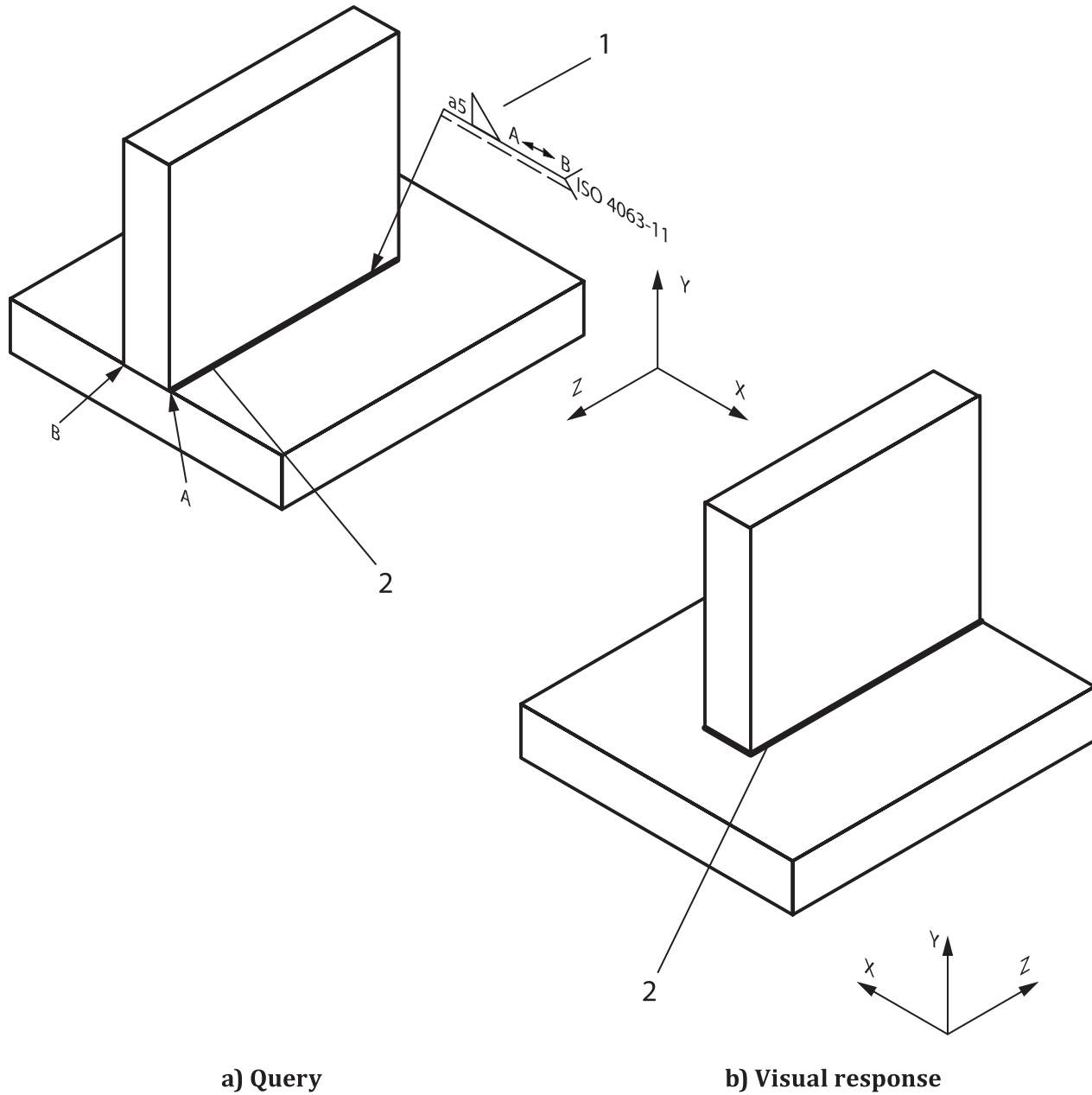

Key

- 1 query
- 2 visual response

Figure 76 — Indication of weld paths

12.4 Drawing requirements

In axonometric views, the extents of the weld can be indicated as they are on models (see [12.3.3](#)).

13 Surface texture

13.1 General

Surface texture symbols shall be in accordance with ISO 1302. This clause establishes the placement, attachment, and display requirements and other provisions for surface texture symbols.

13.2 Common requirements

There are no common exceptions or additions between models and drawings.

13.3 Model requirements

13.3.1 Display techniques

The preferred method for the display of surface texture symbols in 3D models is by an attachment to a reference line with a leader (see [Figure 77](#)) or attachment to other dimension or tolerance indications (see [Figure 78](#)). When a leader is used, it should terminate with a dot on the surface.

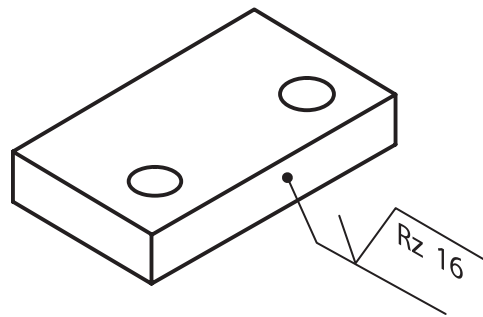

Figure 77 — Surface texture attached with a leader to a surface

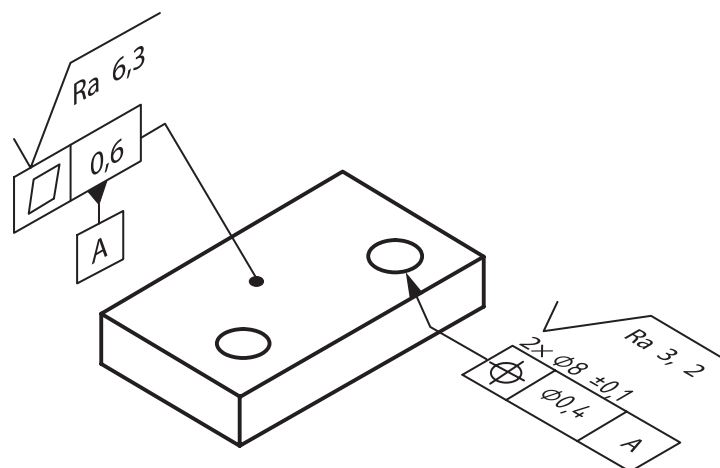

Figure 78 — Surface texture attached to tolerance indications

The surface texture symbol can also be placed before or after the dimension for a feature of size (see [Figure 79](#)) or to the extension line of a dimension (see [Figure 80](#)).

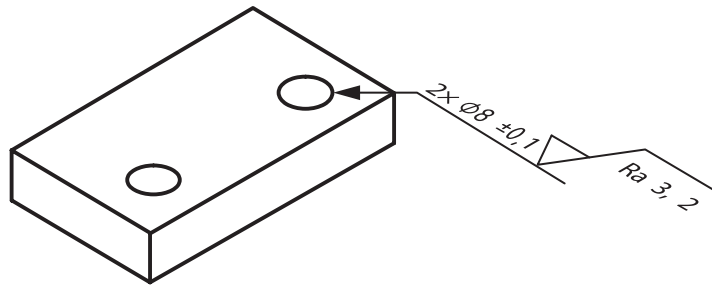

Figure 79 — Surface texture attached to a dimension

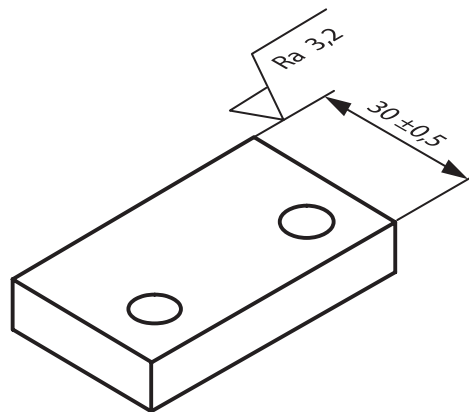

Figure 80 — Surface texture attached to a dimension extension line

The following techniques defined in ISO 1302 are not recommended for the display of surface texture symbols on models:

- single extension lines of model feature outlines;
- direct placement of the surface texture symbol to the geometry.

13.3.2 Annotation plane

The surface texture symbol shall be placed in an annotation plane that is parallel to, perpendicular to, or coincident with one of the surfaces to which it applies.

13.3.3 Associativity

The portions of the model to which the surface texture applies shall be the associated geometry for the surface texture symbol.

13.3.4 Indication of direction of lay

When the lay is direction-dependent, such as parallel or perpendicular, the direction shall be explicitly indicated. This may be accomplished using supplemental geometry or association to an axis of a model coordinate system. The direction of the supplemental geometry should be appropriate for the direction-dependent lay symbol. The perpendicular or parallel lay is relative to the direction of the supplemental geometry.

When supplemental geometry is used to indicate the direction of the lay, the surface texture symbol shall be indicated with a reference line and a leader and the leader shall terminate on the supplemental geometry with an arrowhead (see [Figure 81](#)).

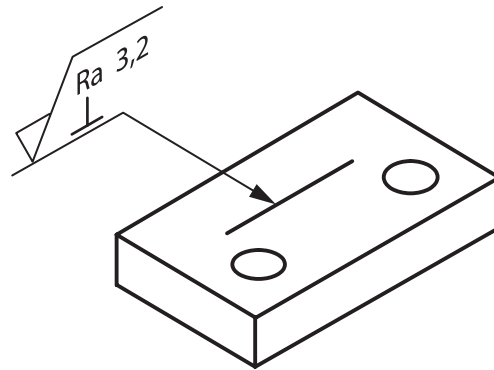
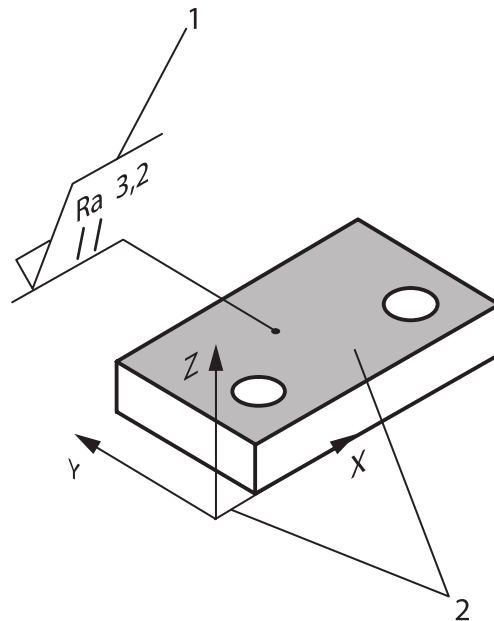

Figure 81 — Direction of lay with supplemental geometry



Key

- 1 query
- 2 visual response

Figure 82 — Direction of lay by ordinate axes

13.3.5 Use of all around indication

The appropriate surfaces shall be designated as the associated geometry, making the use of the all around indication optional. However, the all around indication can be used with surface texture symbols on models if needed to provide additional clarity (see [Figure 83](#)).

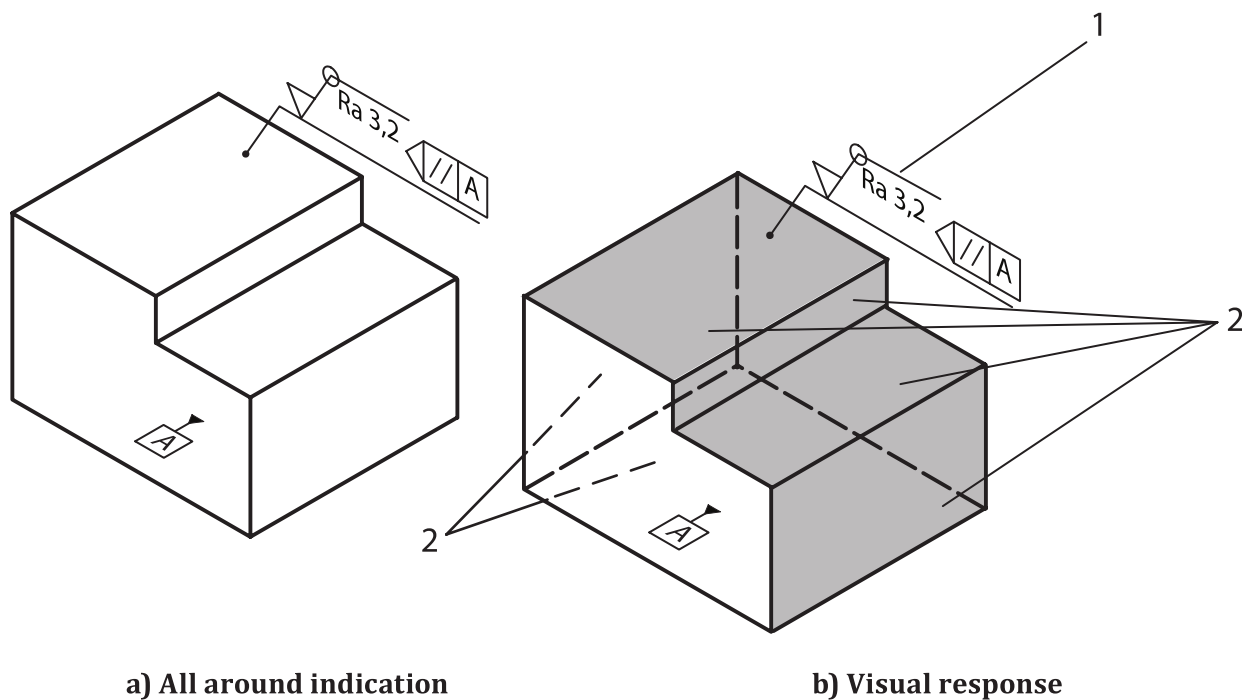

Key

- 1 query
- 2 visual response

Figure 83 — Surface texture requirement for all six surfaces represented by outline on workpiece

13.4 Drawing requirements

In axonometric views, the direction of lay can be indicated using supplemental geometry as it is on models (see [13.3.3](#)).

Annex A (informative)

Classification codes for drawings and data sets

A.1 General

This Annex establishes the requirements for classification codes for defining what data are included within the drawing, data set, or both.

A.2 Application

The classification code can be used to indicate how the product definition data are organized within the data set. When both a model and a drawing are provided, the classification code defines whether the model, the drawing, or both provide the complete definition of the product. The indication of the classification code should appear on the model if one is included, on the drawing if used, and in the associated list(s) if used. See [A.4.2](#) for the location of the classification code.

A.3 Definitions

See [3.2](#) for the terms and definitions related to classification codes for drawings and data sets.

A.4 Classification code requirements

A.4.1 General

Identify classification codes as specified herein.

A.4.2 Classification code location

On a model, the classification code shall be placed on an annotation plane or by a similar method.

On a drawing, the classification code shall be displayed on a drawing.

The classification code shall be placed on the associated list(s).

A.4.3 Classification code 1

The following applies to classification code 1, drawing with optional data set:

- a) the data set, when used, shall be stored in a repository;
- b) when a data set is used, the drawing shall be included in the data set;
- c) the drawing shall be released and is the original;
- d) the drawing and related data shall provide complete product definition.

A.4.4 Classification code 2

The following applies to classification code 2, data set with model and drawing:

- a) the data set shall be stored in a repository;

- b) a drawing shall be included in the data set;
- c) the drawing and related data shall provide complete product definition;
- d) the drawing is released and is the original.

A.4.5 Classification code 3

The following applies to classification code 3, data set with model and simplified drawing:

- a) the data set is the original and shall be stored in a repository;
- b) the data set with model and the drawing shall be used as a set with the related data and shall provide complete product definition.

A.4.6 Classification code 4

The following applies to classification code 4, data set with model and drawing:

- a) the data set is the original and shall be stored in a repository;
- b) a drawing shall be included in the data set;
- c) the data set with model and related data shall provide complete product definition;
- d) the drawing and related data shall provide complete product definition.

A.4.7 Classification code 5

The following applies to classification code 5, data set with model:

- a) the data set is the original and shall be stored in a repository;
- b) the data set with model and related data shall provide complete product definition;
- c) there shall not be a drawing.

Bibliography

- [1] ISO 2768-1:1989, *General tolerances — Part 1: Tolerances for linear and angular dimensions without individual tolerance indications*
- [2] ISO 8015, *Geometrical product specifications (GPS) — Fundamentals — Concepts, principles and rules*
- [3] ISO 12944 (all parts), *Paints and varnishes — Corrosion protection of steel structures by protective paint systems*
- [4] ISO 14638:2015, *Geometrical product specifications (GPS) — Matrix model*
- [5] ASME Y14.41:2012, *Digital Product Definition Data Practices*
- [6] ASME Y14.100, *Engineering Drawing Practices*

ISO 16792:2015(E)

ICS 35.240.10; 01.110

Price based on 111 pages