

---

---

**Sensory analysis — Apparatus — Olive  
oil tasting glass**

*Analyse sensorielle — Appareillage — Verre pour la dégustation de  
l'huile d'olive*



**PDF disclaimer**

This PDF file may contain embedded typefaces. In accordance with Adobe's licensing policy, this file may be printed or viewed but shall not be edited unless the typefaces which are embedded are licensed to and installed on the computer performing the editing. In downloading this file, parties accept therein the responsibility of not infringing Adobe's licensing policy. The ISO Central Secretariat accepts no liability in this area.

Adobe is a trademark of Adobe Systems Incorporated.

Details of the software products used to create this PDF file can be found in the General Info relative to the file; the PDF-creation parameters were optimized for printing. Every care has been taken to ensure that the file is suitable for use by ISO member bodies. In the unlikely event that a problem relating to it is found, please inform the Central Secretariat at the address given below.

© ISO 2006

All rights reserved. Unless otherwise specified, no part of this publication may be reproduced or utilized in any form or by any means, electronic or mechanical, including photocopying and microfilm, without permission in writing from either ISO at the address below or ISO's member body in the country of the requester.

ISO copyright office  
Case postale 56 • CH-1211 Geneva 20  
Tel. + 41 22 749 01 11  
Fax + 41 22 749 09 47  
E-mail [copyright@iso.org](mailto:copyright@iso.org)  
Web [www.iso.org](http://www.iso.org)

Published in Switzerland

## Foreword

ISO (the International Organization for Standardization) is a worldwide federation of national standards bodies (ISO member bodies). The work of preparing International Standards is normally carried out through ISO technical committees. Each member body interested in a subject for which a technical committee has been established has the right to be represented on that committee. International organizations, governmental and non-governmental, in liaison with ISO, also take part in the work. ISO collaborates closely with the International Electrotechnical Commission (IEC) on all matters of electrotechnical standardization.

International Standards are drafted in accordance with the rules given in the ISO/IEC Directives, Part 2.

The main task of technical committees is to prepare International Standards. Draft International Standards adopted by the technical committees are circulated to the member bodies for voting. Publication as an International Standard requires approval by at least 75 % of the member bodies casting a vote.

Attention is drawn to the possibility that some of the elements of this document may be the subject of patent rights. ISO shall not be held responsible for identifying any or all such patent rights.

ISO 16657 was prepared by Technical Committee ISO/TC 34, *Food products*, Subcommittee SC 12, *Sensory analysis*.



# Sensory analysis — Apparatus — Olive oil tasting glass

## 1 Scope

This International Standard specifies the characteristics of a glass intended for use in the sensory analysis of the organoleptic attributes of odour, taste and flavour of virgin olive oils, for the classification of such oils. The glass is not intended for the analysis of the colour or texture of olive oils.

In addition, it describes an adapted heating unit used to reach and maintain the right temperature for this analysis.

## 2 Description of the glass

### 2.1 General

The optimum characteristics desirable in a piece of apparatus of this kind can be specified as follows:

- a) maximum steadiness, to prevent the glass from tilting and the oil from being spilled;
- b) a base that easily fits the indentations of the heating unit so that the bottom of the glass is evenly heated;
- c) a narrow mouth, which helps to concentrate the odours and facilitates their identification;
- d) made of dark-coloured glass to prevent the taster from perceiving the colour of the oil, thus eliminating any prejudices and impeding the possible formation of biases or tendencies that might affect the objectivity of the determination.

### 2.2 Dimensions

The glass, shown in Annex A, shall have the following dimensions:

Total capacity	130 ml $\pm$ 10 ml
Total height	60 mm $\pm$ 1 mm
Diameter of mouth	50 mm $\pm$ 1 mm
Diameter of glass at its widest	70 mm $\pm$ 1 mm
Base diameter	35 mm $\pm$ 1 mm
Thickness of glass on sides	1,5 mm $\pm$ 0,2 mm
Thickness of glass base	5 mm $\pm$ 1 mm

Each glass shall be equipped with a watch-glass, the diameter of which shall be 10 mm larger than the mouth of the glass. This watch-glass shall be used as a cover to prevent the loss of aroma and the entry of dust.

### 2.3 Manufacturing characteristics

The glass shall be made of resistant glass. It shall be dark coloured so that the colour of its contents cannot be discerned, and shall be free from scratches or bubbles.

The rim shall be even, smooth and flanged.

The glass shall be annealed so that it withstands the temperature changes it has to undergo in the tests.

### 2.4 Instructions for use

The glasses shall be cleaned using unperfumed soap or detergent and shall then be rinsed repeatedly until the cleaning agent has been totally eliminated. The final rinse shall be with distilled water, after which the glasses shall be left to drain and then dried in a desiccation stove.

Neither concentrated acids nor chromic acid mixtures shall be used.

The glasses shall be kept in the stove until required for use, or shall be kept in a cupboard in which they shall be protected from contamination by any extraneous odours.

## 3 Device for heating samples

The samples shall be sensorially examined at a set temperature which, in the case of virgin olive oils, shall be between 28 °C and 30 °C. For this purpose, a heating device (see Annex B for an example) shall be installed in each booth within the taster's reach.

**Annex A**  
(normative)

**Dimensions of tasting glass for olive oil**

Dimensions in millimetres

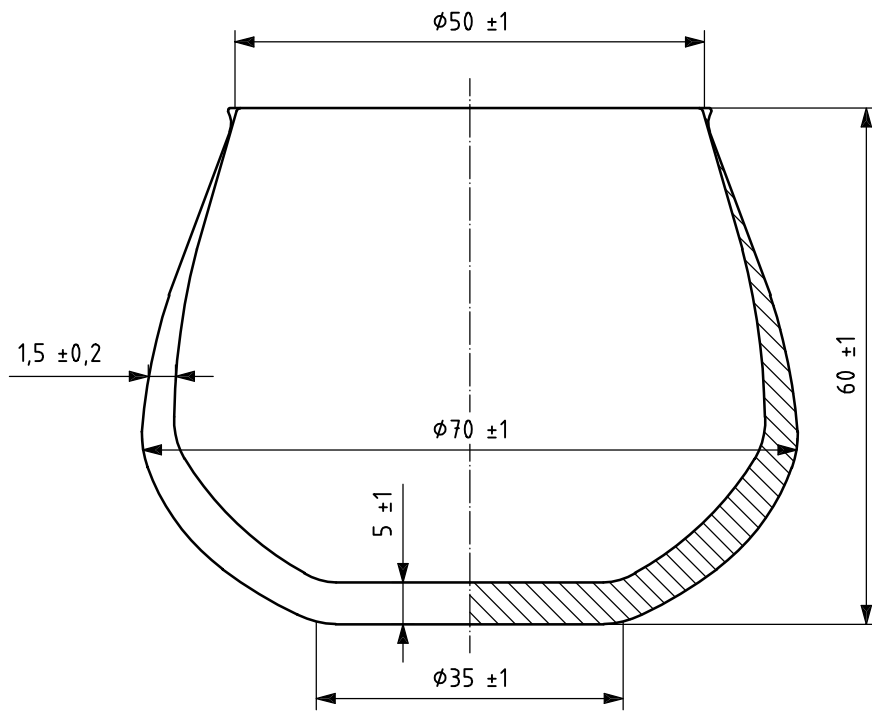

## Annex B (informative)

### Example of device for heating samples

Dimensions in millimetres

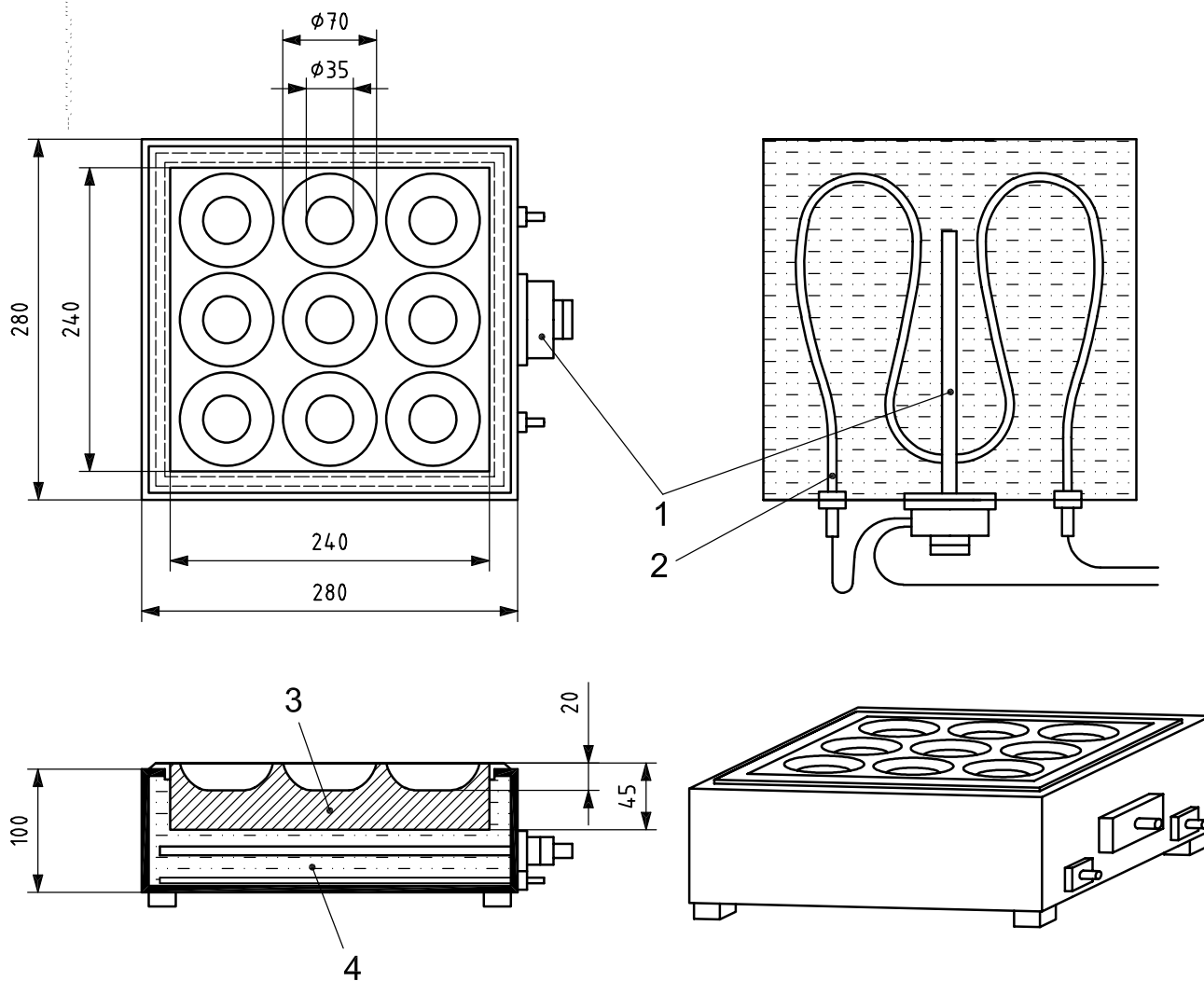

#### Key

- 1 thermostat
- 2 heating coil
- 3 aluminium block
- 4 water bath



## Bibliography

- [1] Conseil Oléicole International/T.20/Doc. No. 15/Rev. 1, *Organoleptic assessment of virgin olive oil*, 20 November 1996
- [2] Conseil Oléicole International/T.20/Doc. No. 5, *Sensory analysis of olive oil — Standard — Glass for oil tasting*, 18 June 1987

