**Mobile elevating work platforms —
Design, calculations, safety requirements
and test methods relative to special
features —**

Part 2:
**MEWPs with non-conductive (insulating)
components**

*Plates-formes élévatrices mobiles de personnel — Conception, calculs,
exigences de sécurité et méthodes d'essai concernant les
caractéristiques spéciales —*

Partie 2: PEMP avec composants non conducteurs (isolants)



PDF disclaimer

This PDF file may contain embedded typefaces. In accordance with Adobe's licensing policy, this file may be printed or viewed but shall not be edited unless the typefaces which are embedded are licensed to and installed on the computer performing the editing. In downloading this file, parties accept therein the responsibility of not infringing Adobe's licensing policy. The ISO Central Secretariat accepts no liability in this area.

Adobe is a trademark of Adobe Systems Incorporated.

Details of the software products used to create this PDF file can be found in the General Info relative to the file; the PDF-creation parameters were optimized for printing. Every care has been taken to ensure that the file is suitable for use by ISO member bodies. In the unlikely event that a problem relating to it is found, please inform the Central Secretariat at the address given below.



COPYRIGHT PROTECTED DOCUMENT

© ISO 2009

All rights reserved. Unless otherwise specified, no part of this publication may be reproduced or utilized in any form or by any means, electronic or mechanical, including photocopying and microfilm, without permission in writing from either ISO at the address below or ISO's member body in the country of the requester.

ISO copyright office
Case postale 56 • CH-1211 Geneva 20
Tel. + 41 22 749 01 11
Fax + 41 22 749 09 47
E-mail copyright@iso.org
Web www.iso.org

Published in Switzerland

Contents

Page

Foreword.....	iv
Introduction	v
1 Scope	1
2 Normative references	1
3 Terms and definitions.....	2
4 List of hazards.....	2
5 Safety requirements and/or protective measures	3
5.1 Structural calculations	3
5.2 Hydraulic liquid	3
5.3 Non-conductive hydraulic and pneumatic hoses.....	3
5.4 Work platforms.....	3
5.5 Electrical requirements	3
6 Verification of the safety requirements and/or protective measures	5
6.1 Type tests	5
6.2 Dielectric tests	5
6.3 Electrical tests.....	6
6.4 Initial inspection and test.....	12
7 Information for use	12
7.1 General.....	12
7.2 Instruction handbook	12
7.3 Markings	12
8 Safety principles, inspection, maintenance and operation	13
8.1 General.....	13
8.2 Maintenance	13
8.3 Modifications or alterations.....	18
Annex A (informative) Sample of manufacturer's plate information.....	19

Foreword

ISO (the International Organization for Standardization) is a worldwide federation of national standards bodies (ISO member bodies). The work of preparing International Standards is normally carried out through ISO technical committees. Each member body interested in a subject for which a technical committee has been established has the right to be represented on that committee. International organizations, governmental and non-governmental, in liaison with ISO, also take part in the work. ISO collaborates closely with the International Electrotechnical Commission (IEC) on all matters of electrotechnical standardization.

International Standards are drafted in accordance with the rules given in the ISO/IEC Directives, Part 2.

The main task of technical committees is to prepare International Standards. Draft International Standards adopted by the technical committees are circulated to the member bodies for voting. Publication as an International Standard requires approval by at least 75 % of the member bodies casting a vote.

Attention is drawn to the possibility that some of the elements of this document may be the subject of patent rights. ISO shall not be held responsible for identifying any or all such patent rights.

ISO 16653-2 was prepared by Technical Committee ISO/TC 214, *Elevating work platforms*.

ISO 16653 consists of the following parts, under the general title *Mobile elevating work platforms — Design, calculations, safety requirements and test methods relative to special features*:

- *Part 1: MEWPs with retractable guardrail systems*
- *Part 2: MEWPs with non-conductive (insulating) components*

MEWPs for orchard operations are to form the subject of a future part 3.

Introduction

The object of ISO 16653 is to define rules for safeguarding persons and objects against the risk of accident associated with the operation of special-application mobile elevating work platforms (MEWPs).

The requirements of ISO 16653 are intended to supplement or modify those of ISO 16368. Unless specified otherwise within this part of ISO 16653, all the relevant provisions of ISO 16368 are applicable in addition to the provisions of this part of ISO 16653.

ISO 16653 does not repeat all the general technical rules applicable to every electrical, mechanical or structural component.

The safety requirements of this part of ISO 16653 have been drawn up on the basis that MEWPs are periodically maintained according to the manufacturer's instructions, working conditions, frequency of use and applicable regulations.

It is assumed that MEWPs will be checked for function daily before start of work and that they will not be put into operation unless all required control and safety devices are available and in working order.

If a MEWP is seldom used, the checks may be made before start of work.

Where, for clarity, an example of a safety measure is given in the text, this is not intended as the only possible solution. Any other solution leading to an equivalent level of safety is permissible.

Mobile elevating work platforms — Design, calculations, safety requirements and test methods relative to special features —

Part 2: MEWPs with non-conductive (insulating) components

1 Scope

This part of ISO 16653 specifies the design, calculations, safety requirements and test methods for mobile elevating work platforms (MEWPs) with non-conductive (insulating) components. It is intended to be used in conjunction with ISO 16368.

It is applicable to all types and sizes of MEWPs with non-conductive (insulating) components, including dielectric components designed and tested to meet the specific electrical properties consistent with the manufacturer's identification plate. This equipment is intended to move persons, tools and equipment to working positions where they can carry out work from a work platform located above a non-conductive boom section.

This part of ISO 16653 covers structural design calculations and the application of stability criteria, construction, safety examinations and tests done before MEWPs with non-conductive (insulating) components are first put into service. It identifies the hazards arising from the use of MEWPs with non-conductive (insulating) components and describes methods for the elimination or reduction of these hazards.

The MEWPs covered are not intended to have any of their components make contact with live parts of electrical installations. The electrical properties of a MEWP's non-conducting (insulating) components can provide electrical protection in case of inadvertent contact above the non-conductive boom component at the platform end. If a MEWP is equipped with a chassis insulating system, it can provide electrical protection for ground personnel in case of inadvertent contact above that system.

This part of ISO 16653 is not applicable to MEWPs designed for live working (see IEC 61057).

2 Normative references

The following referenced documents are indispensable for the application of this document. For dated references, only the edition cited applies. For undated references, the latest edition of the referenced document (including any amendments) applies.

ISO 16368:—¹⁾, *Mobile elevating work platforms — Design, calculations, safety requirements and test methods*

ISO 18893:2004, *Mobile elevating work platforms — Safety principles, inspection, maintenance and operation*

IEC 61057, *Live working — Insulating aerial devices for mounting on a chassis*²⁾

1) To be published. (Revision of ISO 16368:2003)

2) To be published. (Revision of IEC 61057:1991)

3 Terms and definitions

For the purposes of this document, the following terms and definitions apply.

3.1 chassis insulating system
 system of non-conductive (insulating) components installed between the chassis and the structure supporting the upper non-conductive (insulating) boom

NOTE Such a system, when properly maintained, can provide insulation of the chassis should the portion of the MEWP between the upper non-conductive (insulating) boom and this system inadvertently contact an energized conductor or other apparatus.

3.2 electrical insulation level
 level of phase-to-earth (ground) electrical insulation offered by the non-conductive (insulating) components of the upper boom and expressed by the maximum nominal voltage of an electrical installation (line or equipment) in case of inadvertent contact with this installation above the non-conductive (insulating) components at the platform end of the MEWP

NOTE 1 The electrical insulation level is established by the MEWP-responsible entity.

NOTE 2 The electrical insulation level is limited to voltages experienced in electrical distribution systems (46 kV and below).

3.3 insulating liner
 insert made of non-conductive (insulating) material and designed to fit inside the platform

3.4 non-destructive testing
 examination by various means of devices or their components without alteration of the original components, so that they may function as before

NOTE These include acoustic emissions (AE), magnetic particle (MT), liquid penetrant (PT), ultrasonic (UT), radiography (RT), dielectric (DT), and visual (VT).

4 List of hazards

The hazards identified by the risk assessment procedure are presented in Table 1.

Table 1 — List of hazards

Hazards		Relevant subclauses of this part of ISO 16653
1	Electrical hazards , caused for example by:	—
1.1	Electrical contact (direct or indirect)	5.4.2, 5.4.3, 5.5
2	Hazards caused by (temporary) missing and/or incorrectly positioned safety-related measures/means , for example:	—
2.1	Safety signs and signals	7.3.2
2.2	Essential equipment and accessories for safe adjusting and/or maintaining	8.1
3	Markings	7.3

5 Safety requirements and/or protective measures

5.1 Structural calculations

The following sections are to be used for the structural calculations according to ISO 16368:—, 5.2.5.

5.1.1 Bursting safety factors

In addition to the requirements of ISO 16368, all components of the hydraulic system other than pipes connections, hoses and fittings, and hydraulic cylinders, as specified in ISO 16368:—, 5.9.2, 5.9.3 and 5.10, shall be rated according to performance criteria, such as rated flow and pressure, life cycles, pressure drop, revolutions per minute, torque and speed. They shall have a minimum bursting strength of at least two times the operating pressure for which the system is designed. Such components generally include pumps, motors, directional controls and similar functional components.

5.2 Hydraulic liquid

Hydraulic liquid (usually oil or similar fluid) shall meet the requirements of the responsible entity and the insulating requirements of the MEWP.

5.3 Non-conductive hydraulic and pneumatic hoses

Non-conductive hydraulic hoses shall meet the requirements of IEC 61057. Non-conductive pneumatic hoses shall have electrical characteristics similar to non-conductive hydraulic hoses.

5.4 Work platforms

5.4.1 Work platforms constructed from non-conductive materials designed for use without liners

See ISO 16368:—, 5.6.15.

5.4.2 Work platforms designed for use with non-conductive (insulating) liners

Work platforms shall be constructed from non-conductive materials. The work platform shall be identified as non-insulating. Non-conductive (insulating) liners for these work platforms shall be constructed from non-conductive materials and tested in accordance with IEC 61057. The liner shall be supported by the inside bottom surface of the work platform. These non-insulating work platforms shall not have drain holes or access openings. The work platform shall be constructed of materials that will not sustain a flame after an ignition source has been removed.

5.4.3 Non-conductive (insulating) work platforms

Non-conductive (insulating) platforms shall be constructed from non-conductive materials and shall have no drain holes or access openings. Non-conductive (insulating) work platforms shall be tested in accordance with the dielectric tests for insulating liners as defined in IEC 61057. The work platform shall be constructed of materials that will not sustain a flame after an ignition source has been removed.

5.5 Electrical requirements

5.5.1 Non-conductive (insulating) components

All components crossing non-conductive (insulating) portions of the applicable MEWP shall have appropriate electrical insulating properties in order that it complies with the test requirements of this part of ISO 16653. All non-conductive (insulating) systems shall maintain the electrical insulating values in all working boom positions, as defined by the responsible entity.

5.5.2 Vacuum prevention systems

All MEWPs with non-conductive (insulating) components having a nominal platform height greater than 15 m shall have a method for preventing vacuum formation and the resulting reduction in dielectric strength in all hydraulic or pneumatic hoses that cross non-conductive (insulating) sections.

5.5.3 Hydraulic and pneumatic hose

All hydraulic and pneumatic hoses crossing the non-conductive (insulating) portion of the upper boom shall be tested in accordance with IEC 61057.

5.5.4 Lower test electrode system for MEWPs with non-conductive (insulating) components

Some MEWPs with non-conductive (insulating) components may be equipped with a lower test electrode system. If so equipped, this system shall meet the lower test electrode system requirements of IEC 61057.

5.5.5 Chassis insulating system

MEWPs with a chassis insulating system shall have a means provided to bypass the chassis insulating system during dielectric tests. See Figure 1.

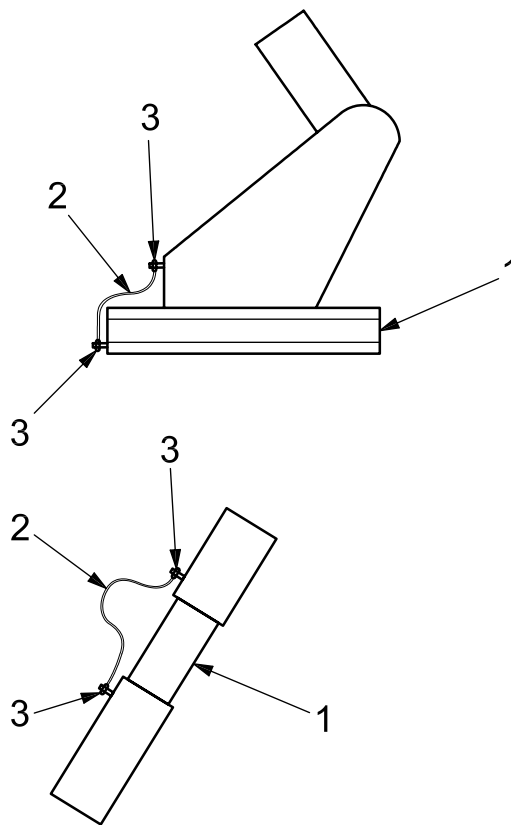

Key

- 1 insulating system
- 2 temporary shunt (remove after test)
- 3 stainless steel stud with 25 mm thread exposed

Figure 1 — Suggested shunting arrangement for chassis insulating systems

6 Verification of the safety requirements and/or protective measures

6.1 Type tests

Each MEWP with non-conductive (insulating) components shall be type-tested in accordance with ISO 16368:—, 6.2. This identifies the test to be performed in lieu of ISO 16368:—, 6.1.3 a) and b).

6.2 Dielectric tests³⁾

6.2.1 Test criteria for MEWPs with a non-conductive (insulating) boom

Each MEWP with non-conductive (insulating) upper boom shall undergo one of the tests described in Table 2 to verify the insulating performance of the components of the non-conductive (insulating) boom assembly. This test may be conducted before or after installation on a chassis.

When a MEWP is modified or altered after the dielectric test prior to mounting, the test shall be performed again following the modification or alteration.

NOTE Alteration or modification includes such things as the addition of another platform, a jib, a winch, or other auxiliary devices, and other alterations. The installer is also cautioned that the addition of devices is carried out with the written approval of the responsible entity in order that the requirement for design testing is met.

Table 2 — Dielectric test values for MEWPs with non-conductive (insulating) boom

Test for MEWPs with lower test electrode system	
Required 50 Hz to 60 Hz test voltage (rms kV) for 1 min	Maximum allowable current
Line-to-earth (ground) voltage of nominal line voltage ^a X 2	1 µA per kilovolt of test voltage
Test for MEWPs without lower test electrode system	
Required 50 Hz to 60 Hz test voltage (rms kV) for 3 min	Maximum allowable current
Line-to-earth (ground) voltage of nominal line voltage ^a X 2	10 µA per kilovolt of test voltage
^a Nominal line voltage (rms kV) reflects the responsible entity's rated electrical insulation level and shall be not more than 46 kV.	

6.2.2 Test criteria for MEWPs with a chassis insulating system

Each MEWP equipped with a chassis insulating system shall undergo a dielectric test to verify the non-conductivity or insulating quality of the non-conductive (insulating) components of the chassis insulating system. The test shall be carried out in accordance with 6.3.4. The test voltage shall be applied to the metal above the chassis insulating system. The test voltage shall be 50 kV (rms) at a frequency of 50 Hz to 60 Hz and shall be applied for 3 min. The current shall not exceed 3 mA.

3) MEWPs rated or valued by a responsible entity as being capable of live working are not covered by this part of ISO 16653 (see IEC 61057).

6.3 Electrical tests⁴⁾

6.3.1 Test criteria for MEWPs with non-conductive (insulating) boom including lower test electrode system

These are as follows.

- a) All metal at the platform end of the non-conductive (insulating) boom shall be electrically bonded during the test.
- b) The lower test electrode system shall be inspected for completeness and tested for continuity to confirm that it is intact. Any problem found shall be corrected before testing continues.
- c) All hoses crossing the non-conductive (insulating) boom section shall be completely filled with hydraulic liquid during the test.
- d) Elbows shall be shunted as shown in Figure 2.
- e) Chassis insulating systems, if provided, shall be shunted as shown in Figure 1.
- f) The vehicle chassis or test stand shall be earthed.
- g) The current meter receptacle shall be connected through a shielded cable to a current meter and then to earth.
- h) Booms shall be positioned in accordance with Figure 2 or Figure 3.
- i) The test criteria of Table 2 shall apply.
- j) The current value and voltage shall be documented.

6.3.2 Test criteria for MEWPs having non-conductive (insulating) components without lower test electrode system

These are as follows.

- a) All metal at the platform end of the non-conductive (insulating) boom shall be electrically bonded during the test.
- b) All hoses crossing the non-conductive (insulating) boom section shall be completely filled with hydraulic liquid during the test.
- c) All elbows should be shunted to ensure good continuity. If good continuity across the elbow cannot be ensured, shunting shall be required (see Figure 4).
- d) Chassis insulating systems, if provided, shall be shunted as shown in Figure 1.
- e) The MEWP shall be tested as shown in Figure 4.
- f) The MEWP or test stand shall be connected through a shielded cable to a current meter and then connected to earth.
- g) Booms shall be positioned as shown in Figure 2 or Figure 3.
- h) The test criteria of Table 2 shall apply.

4) These specific electrical tests are designed to ensure consistency in testing practices.

- i) The current value and voltage shall be documented.
- j) Insulating pads shall be installed under the wheels.

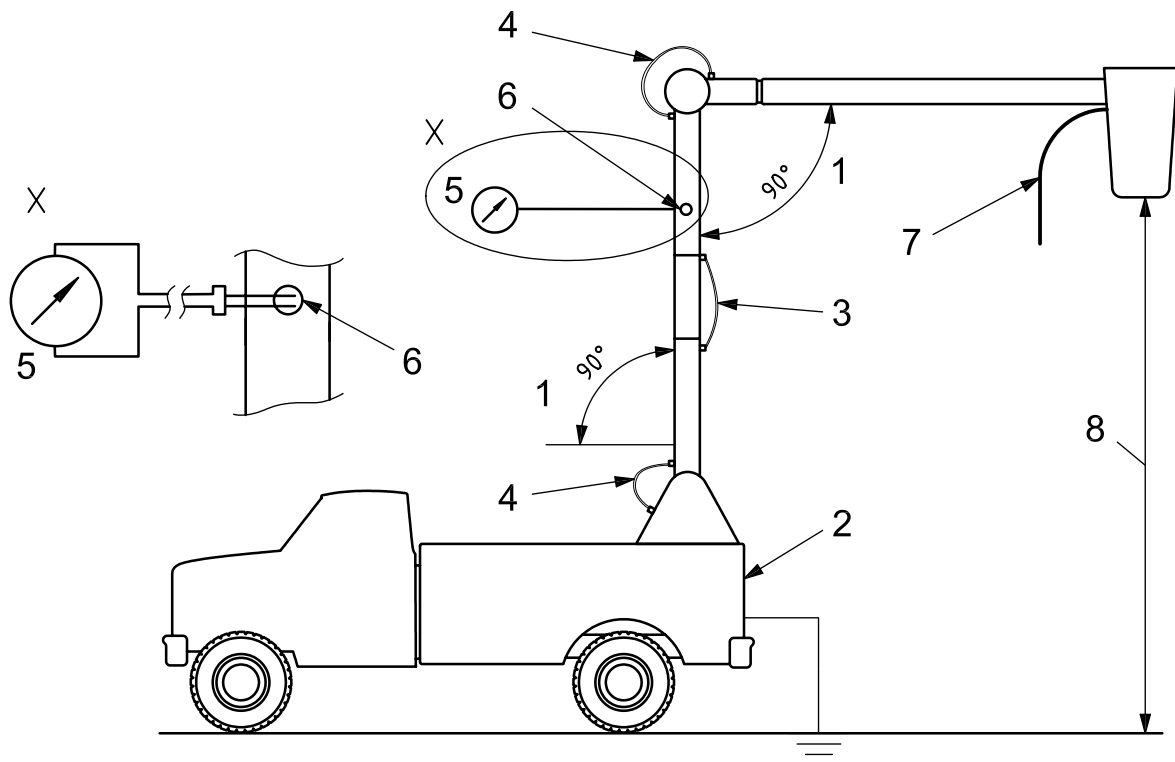

Key

- 1 reference boom positions for outdoor testing ^a
- 2 test stand or vehicle is earthed
- 3 chassis insulating system shunt
- 4 shunting jumper
- 5 current meter
- 6 meter receptacle
- 7 voltage source (a.c. or d.c.)
- 8 platform height recorded for consistency or duplication of test results

^a Other positions are acceptable — when indoor testing, for example. The positions used for a.c. tests should be documented and accompany test documents for test reliability.

Figure 2 — Test configuration for MEWPs with non-conductive (insulating) boom including lower test electrode system

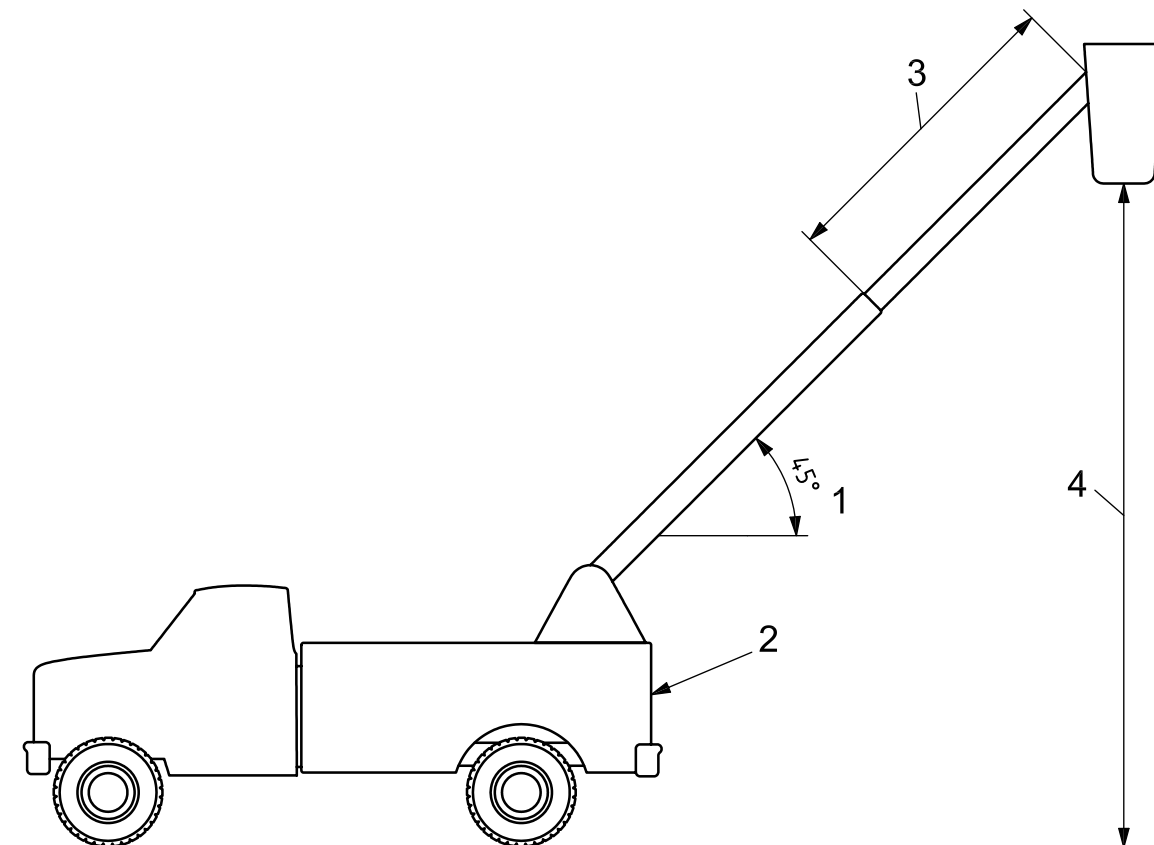

Key

- 1 reference boom position ^a
- 2 test stand or vehicle
- 3 insulating section extended to minimum extension required by the manufacturer
- 4 platform height recorded for consistency or duplication of test results

^a This boom angle may be altered. However, in the case of 50 Hz to 60 Hz (rms) tests conducted on MEWPs without lower test electrode systems, capacitance considerations are more critical than on MEWPs having lower test electrode systems. Therefore, for purposes of repeatability, care should be taken to document the boom position used.

Figure 3 — Boom configuration for dielectric test of extensible MEWPs with non-conductive (insulating) boom

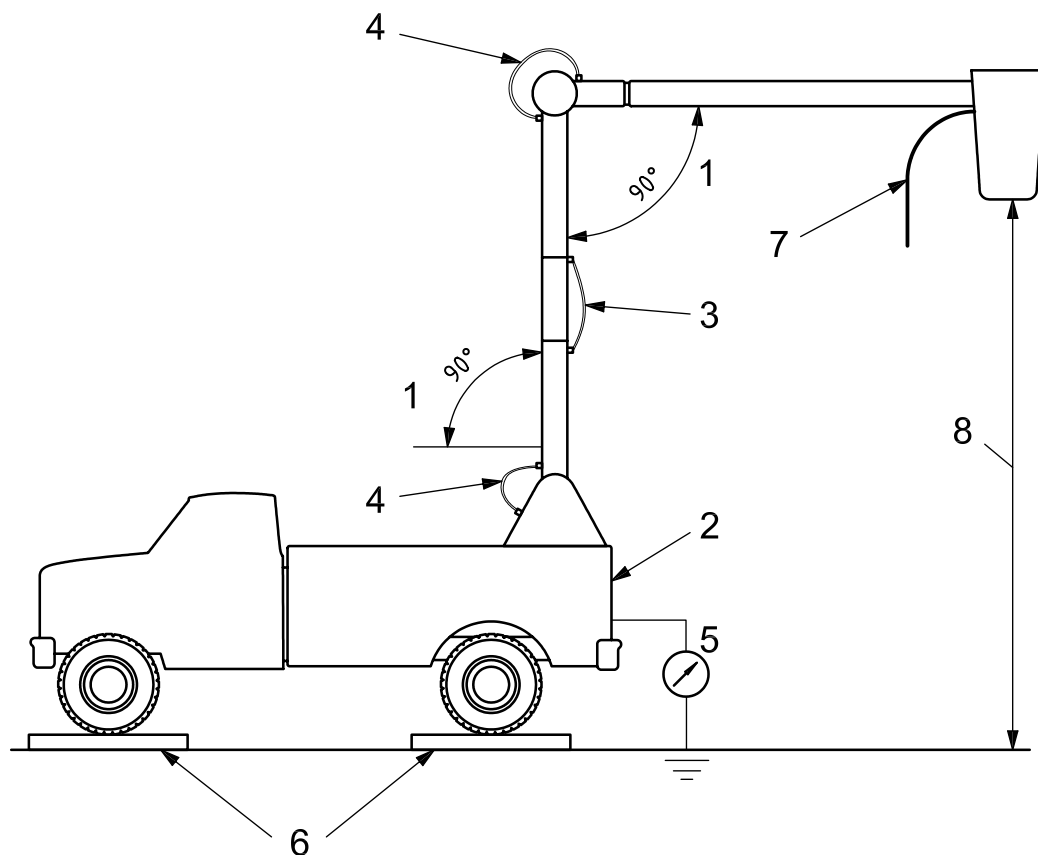

Key

- 1 reference boom positions for outdoor testing ^a
- 2 test stand or vehicle
- 3 chassis insulating system shunt
- 4 shunting jumper
- 5 current meter
- 6 insulating platform under wheels and outriggers
- 7 voltage source (a.c. or d.c.)
- 8 platform height recorded for consistency or duplication of test results

^a Other positions are acceptable — when indoor testing, for example. The positions used for a.c. (rms) tests should be documented and accompany test documents for test reliability. Owing to capacitive currents, these boom angles are more critical than those for MEWPs equipped with lower test electrode systems. If boom positions are altered, for purposes of repeatability, care should be taken to document the positions used.

Figure 4 — Test configuration for MEWPs with non-conductive (insulating) boom without lower test electrode system

6.3.3 Test criteria for aerial ladder and vertical tower MEWPs with non-conductive (insulating) components (sections)

These are as follows.

- a) The test for aerial-ladder-type MEWPs with non-conductive (insulating) components (sections) shall be conducted with the upper section extended only so far as to permit the ladder platform to drop into its operating position or for a predetermined extended length, as indicated on the ladder section.

- b) Aerial-ladder or vertical-tower-type MEWPs with non-conductive (insulating) components (sections) that are stated by the responsible entity as having insulating value shall be tested in accordance with Table 2 and 6.3.1.
- c) The test for vertical-tower-type MEWPs with non-conductive (insulating) components (sections) shall be conducted with the tower platform rails in a raised position within the confines of the platform, and with the unit in a normally stored position or as recommended by the responsible entity.

6.3.4 Test criteria for chassis insulating systems

These are as follows.

- a) All hoses crossing the insulating system shall be filled with hydraulic liquid during the test.
- b) The MEWP shall be connected to a current meter and then connected to earth through a shielded cable.
- c) Booms shall be positioned and testing carried out as shown in Figure 5.
- d) Voltage shall be applied to the metal above the insulating system.
- e) A test voltage of 50 kV (rms) at a frequency of 50 Hz to 60 Hz shall be applied for 3 min. The current shall not exceed 3 mA.

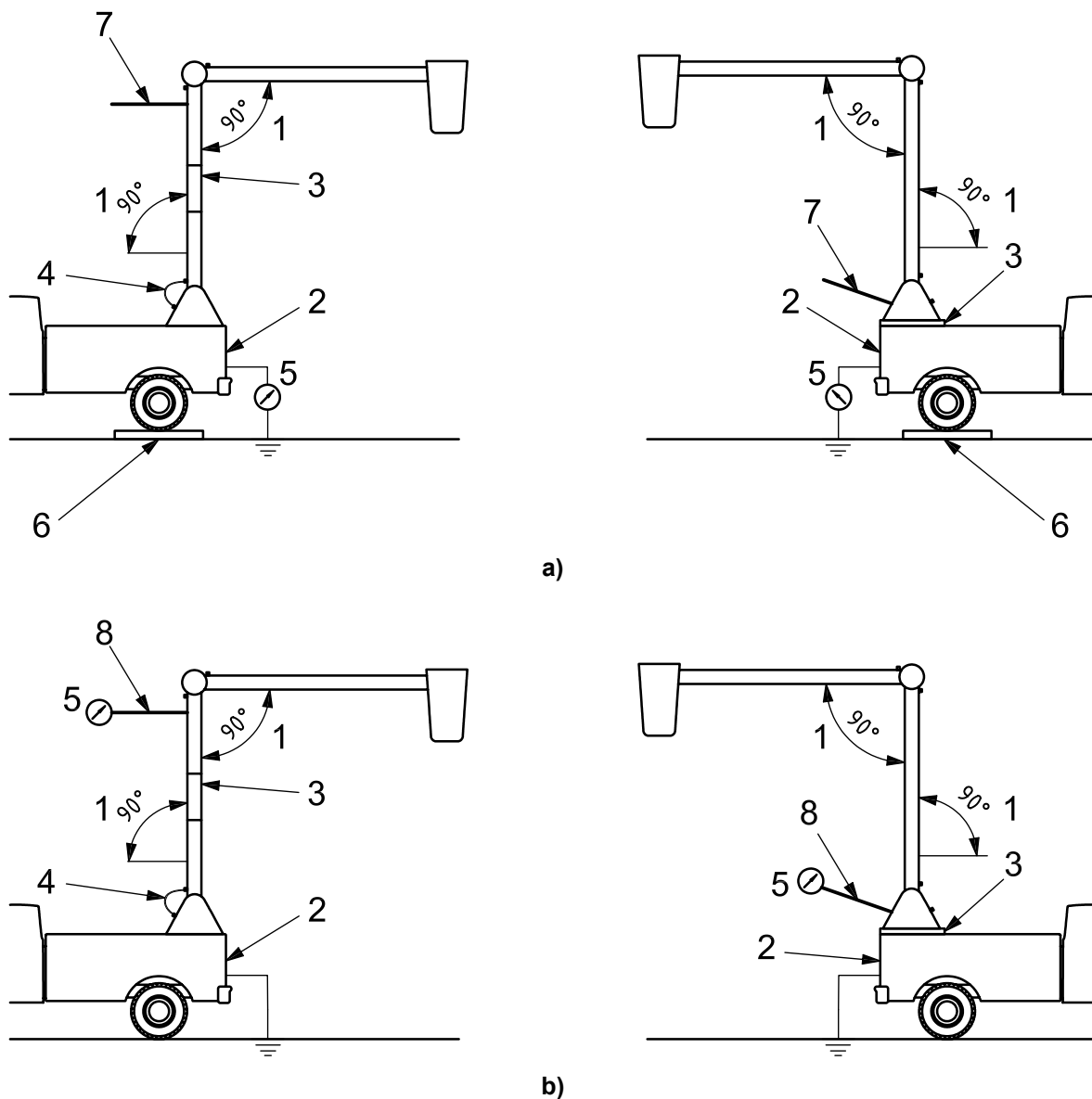

Key

- 1 reference boom positions for outdoor testing ^a
- 2 vehicle or test stand
- 3 chassis insulating system
- 4 optional bonding jumper
- 5 current meter
- 6 insulating platform under wheels and outriggers
- 7 voltage source (a.c. or d.c.)
- 8 voltage source (d.c. only)

^a Either configuration a) or b) is acceptable. Other positions are acceptable — when indoor testing, for example. For purposes of test repeatability, the positions used for a.c. tests should be documented and accompany the test documents.

Figure 5 — Dielectric test configuration for chassis insulating systems

6.3.5 Test criteria for insulating liners

Platform liners shall be tested in accordance with IEC 61057.

6.4 Initial inspection and test

Prior to initial use, all new or modified MEWPs shall be inspected and tested to ensure compliance with the provisions of this part of ISO 16653.

NOTE Verification by the responsible entity or one or more qualified persons meets this requirement.

7 Information for use

7.1 General

In addition to the requirements of ISO 16368 and ISO 18893, the following apply to MEWPs with non-conductive (insulating) components.

7.2 Instruction handbook

The instruction handbook/operator's manual shall contain

- a) descriptions, specifications and dielectric properties of non-conductive components of the MEWP,
- b) replacement part information,
- c) instructional markings according to 7.3, and
- d) inspection and maintenance instructions.

7.3 Markings

7.3.1 General

In no event shall markings be applied which reduce the non-conductive (insulating) properties of the MEWP.

7.3.2 Manufacturer's plate

The MEWP manufacturer shall clearly state in the instruction handbook/operator's manual and on the MEWP the following information:

- a) mention that this equipment is NOT for use on energized electrical lines or apparatus;
- b) cautions and restrictions of operation, including the applicable ambient temperature range in which the MEWP may be used;
- c) designation of the work platform as being designed for use with or without insulating liner;
- d) information on dielectric properties of the non-conductive (insulating) components.

NOTE See Annex A for a sample of information recommended to be included on the manufacturer's plate.

7.3.3 Work platform

The following information shall be permanently and clearly marked at each work platform in an easily visible place. Markings shall be determined by the responsible entity or jointly by the responsible entity and the

custodian to indicate hazards inherent in the operation of a MEWP. Instructional or informational markings shall be provided for the following:

- a) electrical hazards involved in the operation of the machine, warning that a MEWP does not provide protection to the operator when he/she is in contact with, or in close proximity to, electrically charged equipment, conductors or other components when the operator is in contact with, or in close proximity to, another electrical component;
- b) electrical hazards involved in the operation of the machine, warning that a MEWP, when working in proximity to energized conductors, shall be considered energized, and that contact with the MEWP or chassis (including attached trailers) under those conditions may cause serious injuries;
- c) minimum approach distance requirements for energized electrical lines or apparatus, as defined in ISO 18893 or by a governing authority if more stringent.

NOTE Work platforms having non-conductive components are not necessarily insulating.

8 Safety principles, inspection, maintenance and operation

8.1 General

In addition to the requirements of ISO 18893, the following tests shall be performed on MEWPs with non-conductive (insulating) components.

8.2 Maintenance

8.2.1 Pre-start inspection

Items determined by the custodian in accordance with the responsible entity's recommendations for each specific MEWP shall be inspected. The following tests and inspections shall be performed once daily by the operator of a MEWP with non-conductive (insulating) components prior to first use:

- hydraulic or pneumatic systems for observable deterioration or leakage, which may affect insulating properties;
- insulating components and other components made of non-conductive materials for visible damage or contamination;
- electrical systems of, or related to, the MEWP for malfunction, signs of excessive deterioration, dirt and moisture accumulation.

Any suspected items shall be carefully examined or tested and a determination made by a qualified person as to whether they constitute a safety hazard. All unsafe items shall be replaced or repaired before use.

8.2.2 Annual mechanical inspection/testing

In addition to the requirements specified of ISO 18893:2004, 5.3, the following shall be inspected in accordance with the responsible entity's instructions and depending upon its activity, severity of service and environment:

- a) parts, such as pins, bearings, shafts, gears, rollers, locking devices, chains, chain sprockets, wire and synthetic ropes, and sheaves for wear, cracks or distortion;
- b) hydraulic and pneumatic relief valve settings;
- c) hydraulic system for proper liquid level;

- d) hydraulic and pneumatic fittings, hoses and tubing for evidence of leakage, abnormal deformation or excessive abrasion;
- e) compressors, pumps, motors and generators for loose fasteners, leaks, unusual noises or vibrations, loss of operating speed and excessive heating;
- f) hydraulic and pneumatic valves for malfunction and visible cracks in the external valve housing, leaks and sticking spools;
- g) any vacuum prevention systems and the function of such systems;
- h) hydraulic and pneumatic cylinders and holding valves for malfunction and visible damage;
- i) hydraulic and pneumatic filters for cleanliness and the presence of foreign material in the system indicating other component deterioration;
- j) electrical systems and components for deterioration or wear, including those not readily visible on a frequent inspection;
- k) condition and tightness of bolts and other fasteners;
- l) welds, as specified by the responsible entity;
- m) legible and proper identification, operational and instructional markings.

Annual inspection/testing shall also include the following.

- Non-conductive (insulating) components of MEWPs shall be thoroughly inspected for lack of cleanliness and other conditions that compromise insulation and, after cleaning and correction of any of the compromising conditions, shall be tested in accordance with 8.2.3.
- Any non-conductive (insulating) replacement boom shall be tested to ensure conformance with 8.2.3 by the supplier.
- After any event during which structural members of a MEWP are suspected of being subjected to loading or stresses in excess of design stress, for example after an accident involving overturning of the MEWP or application of unintended external mechanical or electrical forces to the MEWP, the MEWP shall be removed from service and subjected to the applicable annual inspection requirements.

In such cases, in addition to annual inspection, supplemental non-destructive examination procedures or other tests to assist in detecting possible structural damage to the MEWP may be required.

All damaged items shall be replaced or repaired before the unit is returned to service.

- A dielectric test shall be made in accordance with 6.2.1 when repairing or replacing insulating components such as booms, hoses or insulating levelling rods.
- Any suspected items shall be carefully examined or tested and a determination made by a qualified person as to whether they constitute a safety hazard. All unsafe items shall be replaced or repaired before use.

8.2.3 Annual confirmation electrical test

Each MEWP with non-conductive (insulating) boom shall be electrically tested once a year (at one- to twelve-month intervals) in accordance with Table 3 to detect changes in dielectric resistance and detect conductivity changes in its non-conductive (insulating) sections.

The chassis insulating system, where present, shall be tested annually in accordance with 8.2.4.4.

The insulating liner, where present, shall be tested annually in accordance to 8.2.4.5.

Table 3 — Annual dielectric test values for MEWPs equipped with non-conductive (insulating) boom

Test for MEWPs when tested using a supplied lower test electrode system (either of the two tests and values below may be used)	
Required 50 HZ to 60 Hz voltage test (rms kV) for 1 min	Maximum allowable current
Line-to-ground voltage of nominal line voltage ^a X 1,5	1 µA per kilovolt of test voltage
or	
Direct current voltage test for 3 min	Maximum allowable current
Line-to-ground voltage of nominal line voltage ^a X $\sqrt{2}$ ^b X 1,5	0,5 µA per kilovolt of test voltage
Test for MEWPs when tested without a lower test electrode system (either of the two tests and values below may be used)	
Required 50 HZ to 60 Hz voltage test (rms kV) for 3 min	Maximum allowable current
Line-to-ground voltage of nominal line voltage ^a X 1,5	10 µA per kilovolt of test voltage
or	
Direct current voltage test for 3 min	Maximum allowable current
Line-to-ground voltage of nominal line voltage ^a X $\sqrt{2}$ ^b X 1,5	1 µA per kilovolt of test voltage
^a Nominal line voltage (rms kV) reflects the responsible entity's rated electrical insulation level and shall be not more than 46 kV.	
^b a.c. to d.c. conversion.	

8.2.4 Electrical tests⁵⁾

8.2.4.1 Test criteria for MEWPs having non-conductive (insulating) components including lower test electrode system

These are as follows.

- a) All conductive material at the upper end of the non-conductive (insulating) boom shall be electrically bonded during the test.
- b) The lower test electrode system shall be inspected for completeness and tested for continuity to confirm that it is intact. Any problems found shall be corrected before testing continues.
- c) All hoses crossing the non-conductive (insulating) boom section shall be completely filled with hydraulic liquid during the test.
- d) Elbows shall be shunted as shown in Figure 2.
- e) Chassis insulating systems, if provided, shall be shunted as shown in Figure 1.
- f) The vehicle chassis shall be earthed.
- g) The current meter receptacle shall be connected through a shielded cable to a current meter (when used) and then to earth.

5) MEWPs rated or valued by a responsible entity as being capable of live working are not covered by this part of ISO 16653 (see IEC 61057).

- h) Booms shall be positioned in accordance with Figure 2.
- i) One or the other of the following tests shall be performed:
 - 1) an rms test voltage in accordance with Table 3;
 - 2) a direct current test voltage in accordance with Table 3.

NOTE Other in-field tests covered in IEC 61057 can serve as a substitute for these annual tests where appropriate arrangements with electricity suppliers can be made.

8.2.4.2 Test criteria for MEWPs having non-conductive (insulating) components without lower test electrode system

These are as follows.

- a) All metal at the platform end of the non-conductive (insulating) boom shall be electrically bonded during the test.
- b) All hoses crossing the non-conductive (insulating) boom section shall be completely filled with hydraulic liquid during the test.
- c) All elbows should be shunted to ensure good continuity. If good continuity across the elbow is in doubt, shunting is required (see Figure 2).
- d) Chassis insulating systems, if provided, shall be shunted as shown in Figure 1.
- e) One or the other of the following tests shall be performed.
 - 1) The MEWP shall be insulated from all paths to earth as shown in Figure 4 and shall be connected through a coaxial cable to a current meter and then to earth. Booms are to be positioned as shown in Figure 4. The current shall not exceed the values given in Table 3.
 - 2) The MEWP shall be earthed, and direct current tests conducted by the alternate method shown in Figure 6 with a current meter connected between the voltage source and the unit. The current shall not exceed the values given in Table 3.

NOTE Other in-field tests covered in IEC 61057 can serve as a substitute for these annual tests where appropriate arrangements with electricity suppliers can be made.

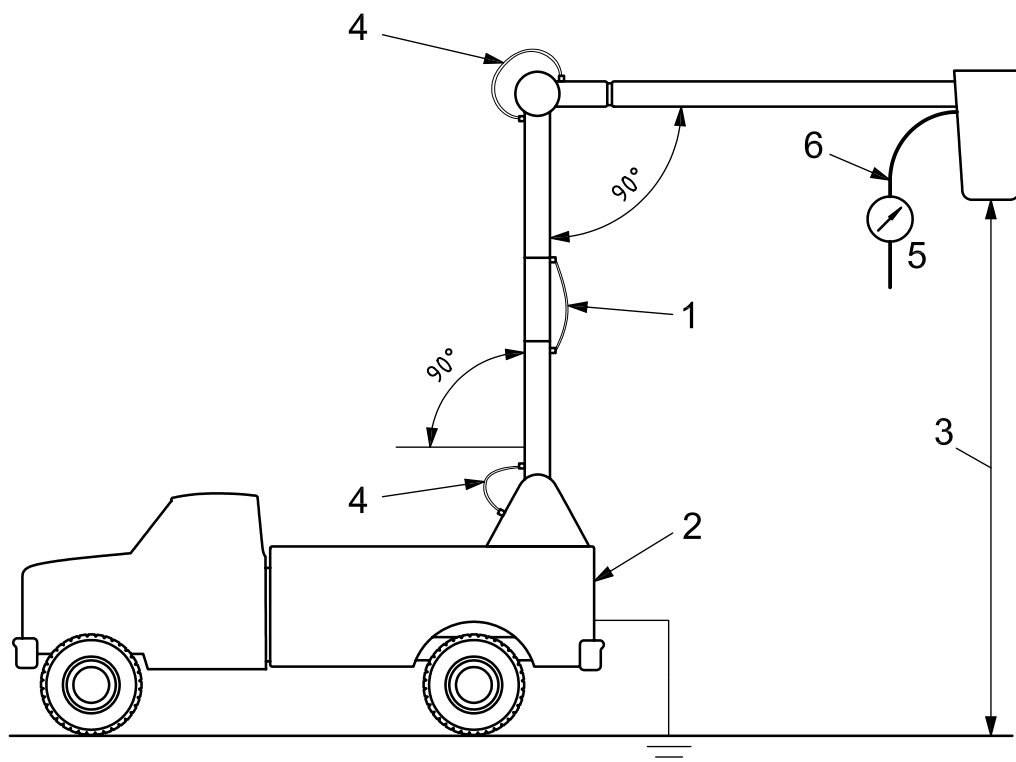
**Key**

- 1 chassis insulating system shunt
- 2 vehicle in test is earthed
- 3 platform height recorded for consistency or duplication of test results
- 4 shunting jumper
- 5 current meter
- 6 voltage source (d.c. only)

Figure 6 — Optional dielectric test configuration for MEWPs without lower test electrode system when conducting direct current test

8.2.4.3 Test criteria for aerial ladder and vertical tower MEWPs with non-conductive (insulating) components (sections)

These are as follows.

- a) The test for aerial-ladder-type MEWPs with non-conductive (insulating) components shall be conducted with the upper section extended only so far as to permit the ladder platform to drop into its operating position or for a predetermined extended length, as indicated on the ladder section.
- b) Aerial-ladder or vertical-tower-type MEWPs with non-conductive (insulating) components (sections) that are stated by the responsible entity as having insulating value shall be tested in accordance with 8.2.3.
- c) The test for vertical tower type MEWPs with non-conductive (insulating) components (sections) shall be conducted with the tower platform rails in a raised position within the confines of the platform, and with the unit in a normally stored position or as recommended by the responsible entity.

8.2.4.4 Test criteria for chassis insulating systems

These are as follows.

- a) All hoses crossing the insulating system shall be filled with hydraulic liquid during the test.

- b) The MEWP shall be connected to a current meter and then connected to earth through a shielded cable.
- c) Booms shall be positioned and testing carried out as shown in Figure 5.
- d) Voltage shall be applied to the metal above the insulating system.
- e) The insulating system shall be tested to 15 kV (rms) at a frequency of 50 Hz to 60 Hz for 3 min: the current shall not exceed 1 mA. Alternatively, the insulating system shall be tested to 25 kV d.c. for 3 min: the current shall not exceed 50 μ A.

8.2.4.5 Test criteria for insulating liners

Platform liners shall be tested in accordance with IEC 61057.

8.2.5 Electrical test equipment

The metering systems, including measurement cable used to measure d.c. current, shall have a system error of 5 % or less.

8.2.6 Electrical certification

The dielectric tests required according to 8.2.1 shall be documented by the entity conducting the tests.

8.3 Modifications or alterations

Modifications or alterations to a MEWP shall be made only with the prior written permission of the responsible entity. In cases where the responsible entity no longer exists, MEWPs may be modified according to the instructions of a qualified person.

NOTE Alterations can include such things as the addition of another platform, a jib, a winch or other auxiliary devices.

A MEWP that has been modified or altered shall be subjected to the electrical tests for verification of non-conductivity according to 6.2.1.

Annex A (informative)

Sample of manufacturer's plate information

Make of mobile elevating work platform (MEWP)

Model: _____

Year of manufacture: _____

Serial No.: _____

This equipment is NOT for use on energized electrical lines or apparatus. It should be considered non-insulating for setting work practices. The non-conductive component systems were dielectrically tested to ensure their integrity on _____ [date of test] to confirm an electrical insulation level for inadvertent contact with the nominal line voltage of _____ kV.

Rated platform height: _____

This mobile elevating work platform complies with the requirements of ISO 16653-2 for MEWPs with non-conductive (insulating) components.

Unit is equipped with _____ platforms.

On a firm and level surface, its capacity is _____ kg or _____ lbs per platform or _____ kg or _____ lbs total.

Date of test: _____

The capacity with outriggers extended to a solid footing is _____ kg or _____ lbs per platform or _____ kg or _____ lbs total.

Date of test: _____

Unit equipped with a material handling attachment: _____ Yes _____ No

MEWP system pressure: _____

MEWP control system voltage: _____

Minimum ambient temperature for operation of the MEWP to maintain structural integrity: _____ °C or _____ °F

MEWP manufacturer: _____

City: _____ State or province: _____ Country: _____

Installed by: _____ City: _____

State or province: _____ Country: _____

