**Geometrical product specifications
(GPS) — Filtration —**

**Part 85:
Morphological areal filters:
Segmentation**

*Spécification géométrique des produits (GPS) — Filtrage —
Partie 85: Filtres surfaciques morphologiques: Segmentation*





COPYRIGHT PROTECTED DOCUMENT

© ISO 2013

All rights reserved. Unless otherwise specified, no part of this publication may be reproduced or utilized otherwise in any form or by any means, electronic or mechanical, including photocopying, or posting on the internet or an intranet, without prior written permission. Permission can be requested from either ISO at the address below or ISO's member body in the country of the requester.

ISO copyright office
Case postale 56 • CH-1211 Geneva 20
Tel. + 41 22 749 01 11
Fax + 41 22 749 09 47
E-mail copyright@iso.org
Web www.iso.org

Published in Switzerland

Contents

	Page
Foreword	iv
Introduction	vi
1 Scope	1
2 Normative references	1
3 Terms and definitions	1
3.1 Geometrical feature terms	1
3.2 Segmentation	3
3.3 Pruning	5
4 Segmentation details	7
4.1 General	7
4.2 Basic segmentation	7
4.3 Watershed segmentation	10
4.4 Watershed segmentation using Wolf pruning	12
5 General information	14
Annex A (informative) Additional information about segmentation	15
Annex B (informative) Wolf pruning examples	16
Annex C (informative) Relationship to the filtration matrix model	21
Annex D (informative) Concept diagrams	22
Annex E (informative) Relation to the GPS matrix model	24
Bibliography	26

Foreword

ISO (the International Organization for Standardization) is a worldwide federation of national standards bodies (ISO member bodies). The work of preparing International Standards is normally carried out through ISO technical committees. Each member body interested in a subject for which a technical committee has been established has the right to be represented on that committee. International organizations, governmental and non-governmental, in liaison with ISO, also take part in the work. ISO collaborates closely with the International Electrotechnical Commission (IEC) on all matters of electrotechnical standardization.

International Standards are drafted in accordance with the rules given in the ISO/IEC Directives, Part 2.

The main task of technical committees is to prepare International Standards. Draft International Standards adopted by the technical committees are circulated to the member bodies for voting. Publication as an International Standard requires approval by at least 75 % of the member bodies casting a vote.

Attention is drawn to the possibility that some of the elements of this document may be the subject of patent rights. ISO shall not be held responsible for identifying any or all such patent rights.

ISO 16610-85 was prepared by Technical Committee ISO/TC 213, *Dimensional and geometrical product specifications and verification*.

This first edition of ISO 16610-85 replaces Annex A (Segmentation) in ISO 25178-2:2012.

ISO 16610 consists of the following parts, under the general title *Geometrical product specifications (GPS) — Filtration*:

- *Part 1: Overview and basic concepts* [Technical Specification]
- *Part 20: Linear profile filters: Basic concepts*
- *Part 21: Linear profile filters: Gaussian filters*
- *Part 22: Linear profile filters: Spline filters*
- *Part 28: Profile filters: End effects* [Technical Specification]
- *Part 29: Linear profile filters: Spline wavelets*
- *Part 30: Robust profile filters: Basic concepts* [Technical Specification]
- *Part 31: Robust profile filters: Gaussian regression filters* [Technical Specification]
- *Part 32: Robust profile filters: Spline filters* [Technical Specification]
- *Part 40: Morphological profile filters: Basic concepts*
- *Part 41: Morphological profile filters: Disk and horizontal line-segment filters*
- *Part 49: Morphological profile filters: Scale space techniques*
- *Part 60: Linear areal filters: Basic concepts*
- *Part 61: Linear areal filters: Gaussian filters*
- *Part 71: Robust areal filters: Gaussian regression filters*
- *Part 85: Morphological areal filters: Segmentation*

The following parts are planned:

- *Part 62: Linear areal filters: Spline filters*

- *Part 69: Linear areal filters: Spline wavelets*
- *Part 70: Robust areal filters: Basic concepts*
- *Part 72: Robust areal filters: Spline filters*
- *Part 80: Morphological areal filters: Basic concepts*
- *Part 81: Morphological areal filters: Sphere and horizontal planar segment filters*
- *Part 82: Morphological areal filters: Motif filters*
- *Part 89: Morphological areal filters: Scale space techniques*

See [Annex C](#) for relationships to other filtration documents.

Introduction

This part of ISO 16610 is a geometrical product specification (GPS) standard and is to be regarded as a general GPS standard (see ISO 14638). It influences the feature characteristics chain link in the GPS matrix structure.

The ISO/GPS Masterplan given in ISO 14638 gives an overview of the ISO/GPS system of which this document is a part. The fundamental rules of ISO/GPS given in ISO 8015 apply to this document and the default decision rules given in ISO 14253-1 apply to specifications made in accordance with this document, unless otherwise indicated.

For more detailed information on the relation of this part of ISO 16610 to other standards and to the GPS matrix model, see [Annex E](#).

This part of ISO 16610 develops the terminology and concepts for areal segmentation.

Geometrical product specifications (GPS) — Filtration —

Part 85:

Morphological areal filters: Segmentation

1 Scope

This part of ISO 16610 develops the terminology and concepts for areal morphological segmentation. In particular, it describes the watershed segmentation method and the Wolf pruning method. This document assumes a continuous surface.

2 Normative references

The following documents, in whole or in part, are normatively referenced in this document and are indispensable for its application. For dated references, only the edition cited applies. For undated references, the latest edition of the referenced document (including any amendments) applies.

ISO 16610-1¹⁾, *Geometrical Product Specifications (GPS) — Data extraction techniques by sampling and filtration — Part 1: Basic terminology*

ISO 25178-2:2012, *Geometrical product specifications (GPS) — Surface texture: Areal — Part 2: Terms, definitions and surface texture parameters*

3 Terms and definitions

For the purposes of this document, the terms and definitions given in ISO 16610-1, ISO 25178-2:2012 and the following apply.

3.1 Geometrical feature terms

3.1.1

peak

point on the surface which is higher than all other points within a neighbourhood of that point

Note 1 to entry: For discrete data, a triangulization of the surface is necessary.

Note 2 to entry: There is a theoretical possibility of a plateau. In practice, this can be avoided by the use of an infinitesimal tilt.

Note 3 to entry: For specific implementation, see ISO 25178-3.

[SOURCE: ISO 25178-2:2012, 3.3.1]

3.1.1.1

Maxwellian hill

region around a peak such that all maximum upward paths end at the peak

Note 1 to entry: In ISO 25178-2:2012, 3.3.1.1, the term corresponding to this definition was “hill”.

1) To be published (Revision of ISO/TS 16610-1:2006).

ISO 16610-85:2013(E)

3.1.1.2

course line

curve separating adjacent hills

[SOURCE: ISO 25178-2:2012, 3.3.1.2]

3.1.1.3

hill

region around a single dominant peak whose boundary consists of a ring of course lines

Note 1 to entry: There may be other peaks in the hill but they will all be insignificant compared to the dominant peak.

3.1.2

pit

point on the surface which is lower than all other points within a neighbourhood of that point

Note 1 to entry: For discrete data, a triangulization of the surface is necessary.

Note 2 to entry: There is a theoretical possibility of a plateau. In practice, this can be avoided by the use of an infinitesimal tilt.

Note 3 to entry: For specific implementation, see ISO 25178-3.

[SOURCE: ISO 25178-2:2012, 3.3.2]

3.1.2.1

Maxwellian dale

region around a pit such that all maximum downward paths end at the pit

Note 1 to entry: In ISO 25178-2:2012, 3.3.1.1, the term corresponding to this definition was “dale”.

3.1.2.2

ridge line

curve separating adjacent dales

[SOURCE: ISO 25178-2:2012, 3.3.2.2]

3.1.2.3

dale

region around a single dominant pit whose boundary consists of a ring of ridge lines

Note 1 to entry: There may be other pits in the dale but they will all be insignificant compared to the dominant pit.

Note 2 to entry: Motifs are dales, see ISO 12085:1996.

3.1.3

saddle

set of points on the surface where ridge lines and course lines cross

[SOURCE: ISO 25178-2:2012, 3.3.3, modified — ISO 25178-2:2012 had “scale-limited ridge lines” in the definition.]

3.1.3.1

saddle point

saddle consisting of one point

[SOURCE: ISO 25178-2:2012, 3.3.3.1]

3.1.4

topographic feature

areal, line or point feature on a surface

[SOURCE: ISO 25178-2:2012, 3.3.4, modified — ISO 25178-2:2012 had “scale-limited surface” in the definition.]

3.1.4.1
areal feature
 hill or dale

[SOURCE: ISO 25178-2:2012, 3.3.4.1]

3.1.4.2
line feature
 course line or ridge line

[SOURCE: ISO 25178-2:2012, 3.3.4.2]

3.1.4.3
point feature
 peak, pit or saddle point

[SOURCE: ISO 25178-2:2012, 3.3.4.3]

3.1.5
contour line
 line on the surface consisting of points of equal height

[SOURCE: ISO 25178-2:2012, 3.3.5]

3.2 Segmentation

3.2.1
segmentation
 method which partitions a surface into distinct regions

[SOURCE: ISO 25178-2:2012, 3.3.6, modified — ISO 25178-2:2012 had “scale-limited surface” in the definition.]

3.2.1.1
event
 mutually exclusive surface portions whose union covers the whole surface

EXAMPLE Ordinate values, Maxwellian hills, Maxwellian dales, etc.

3.2.1.2
watershed segmentation
 segmentation which uses the concept of filling dales (hills) with water to determine the saddle at which the water first overflows and the adjacent dale (hill) into which it overflows

3.2.2
segmentation function
 function which splits a set of events into two distinct sets called the significant events and the insignificant events and which satisfies the three segmentation properties

Note 1 to entry: A full mathematical description of the segmentation function and the three segmentation properties can be found in Scott (2004).^[8]

[SOURCE: ISO 25178-2:2012, 3.3.6.1, modified — Notes 1 and 3 have not been included here.]

3.2.3
first segmentation property

P1
 property where each event is allocated to the set of significant events or the set of insignificant events but not both

$$P1: \quad \forall A \subseteq E, \quad \Psi(A) \cup \Phi(A) = A \text{ and } \Psi(A) \cap \Phi(A) = \emptyset$$

where

- E is the set of all events;
- $\Psi(\cdot)$ maps events onto the set of significant events;
- $\Phi(\cdot)$ maps events onto the set of insignificant events.

SEE: [Figure 1](#).

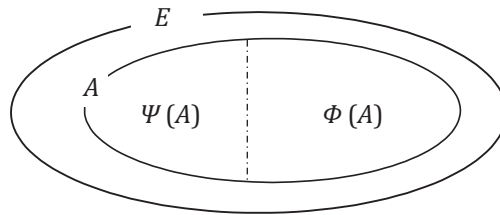

Figure 1 — Venn diagram of first segmentation property

[SOURCE: ISO 25178-2:2012, 3.3.6.2]

3.2.4

second segmentation property

P2
property where a significant event is removed from the set of events then the remaining significant events are contained in the new set of significant events

$$P2: \forall A \subseteq B \subseteq E, \Phi(A) \subseteq \Phi(B)$$

where

- E is the set of all events;
- $\Psi(\cdot)$ maps events onto the set of significant events;
- $\Phi(\cdot)$ maps events onto the set of insignificant events.

SEE: [Figure 2](#).

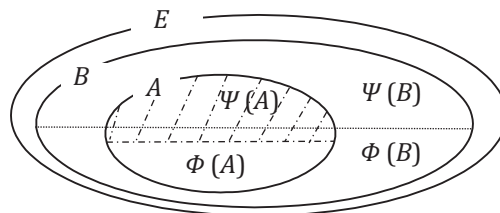

Figure 2 — Venn diagram of second segmentation property

[SOURCE: ISO 25178-2:2012, 3.3.6.3]

3.2.5

third segmentation property

P3

property where an insignificant event is removed from the set of events then the same set of significant events is obtained

$$P3: \forall A \subseteq B \subseteq E, \Psi(B) \subseteq A \Rightarrow \Psi(A) = \Psi(B)$$

where

E is the set of all events;

$\Psi(\cdot)$ maps events onto the set of significant events;

$\Phi(\cdot)$ maps events onto the set of insignificant events.

SEE: [Figure 3](#).

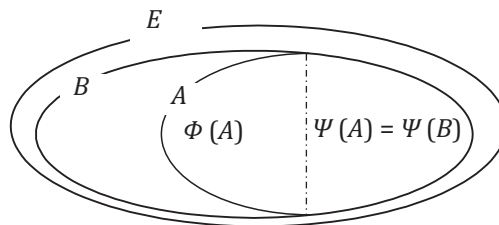

Figure 3 — Venn diagram of third segmentation property

[SOURCE: ISO 25178-2:2012, 3.3.6.4]

3.3 Pruning

3.3.1

change tree

graph where each contour line is plotted as a point against height in such a way that adjacent contour lines are adjacent points on the graph

Note 1 to entry: Peaks and pits are represented on a change tree by the end of lines. Saddle points are represented on a change tree by lines joining. See [Clause 4](#) for more details concerning change trees.

[SOURCE: ISO 25178-2:2012, 3.3.7, modified — The reference in the note has been changed to [Clause 4](#).]

3.3.2

pruning

method to simplify a change tree in which lines from peaks (or pits) to their nearest connected saddle points are removed

[SOURCE: ISO 25178-2:2012, 3.3.7.1]

3.3.3

height

signed normal distance from the reference surface to the surface

Note 1 to entry: The distance is defined normal to the reference surface.

Note 2 to entry: The height is negative, if from the reference surface, the point lies in the direction of the material.

ISO 16610-85:2013(E)

3.3.4

saddle height

height of the saddle

3.3.5

peak height

height of the peak

[SOURCE: ISO 25178-2:2012, 3.3.10]

3.3.5.1

local peak height

difference between the height of a peak and the height of the nearest connected saddle on the change tree

[SOURCE: ISO 25178-2:2012, 3.3.7.2]

3.3.6

pit height

height of the pit

[SOURCE: ISO 25178-2:2012, 3.3.11]

3.3.6.1

local pit height

difference between the height of a pit and the height of the nearest connected saddle on the change tree

[SOURCE: ISO 25178-2:2012, 3.3.7.3]

3.3.7

Wolf pruning

pruning where lines are removed in order from the peak/pit with the smallest local peak/pit height up to the peak /pit with a specified local peak/pit height

Note 1 to entry: The local peak/pit heights will change during Wolf pruning as removing lines from a change tree will also remove the associated saddle point.

Note 2 to entry: Other criteria for pruning are not covered in this part of ISO 16610. See References [9] and [10] for examples.

[SOURCE: ISO 25178-2:2012, 3.3.7.4, modified — Note 2 to entry has been added.]

3.3.7.1

Wolf peak height

minimum height threshold at which a peak is pruned using Wolf pruning

[SOURCE: ISO 25178-2:2012, 3.3.8, modified — The word “height” has been added in the definition.]

3.3.7.2

Wolf pit height

minimum height threshold at which a pit is pruned using Wolf pruning

[SOURCE: ISO 25178-2:2012, 3.3.9, modified — The word “height” has been added in the definition.]

3.3.8

height discrimination

minimum Wolf peak height or Wolf pit height of the surface which should be taken into account

Note 1 to entry: Height discrimination is a nesting index for Wolf pruning segmentation.

[SOURCE: ISO 25178-2:2012, 3.3.12, modified — ISO 25178-2:2012 had “scale-limited surface” in the definition. Note 1 to entry is different.]

3.3.9**virtual pit**

imaginary pit, that has a minus infinity pit height, to which all edge points are connected

3.3.10**virtual pit condition**

condition where a virtual pit is assumed

4 Segmentation details**4.1 General**

A watershed segmentation method claiming to comply with this document shall conform to [4.2](#) to [4.3](#) and a Wolf pruning method claiming to comply with this document shall conform to [4.2](#) to [4.4](#).

4.2 Basic segmentation**4.2.1 General**

Segmentation is a filtration operation (as defined in ISO 16610-1) that spatially decomposes a surface into mutually exclusive portions of that surface (see [Figure 1](#)). Segmentation filtration requires: the objects being filtered i.e. the segments; the rule for segment combination e.g. the watershed rule; and the rule which states which segments are significant e.g. Wolf pruning. Associated with each segmentation method is a nesting index such that large values of the nesting index correspond to large surface portions and smaller values of the nesting index correspond to smaller surface portions (compare [Figures 4](#) and [5](#)).

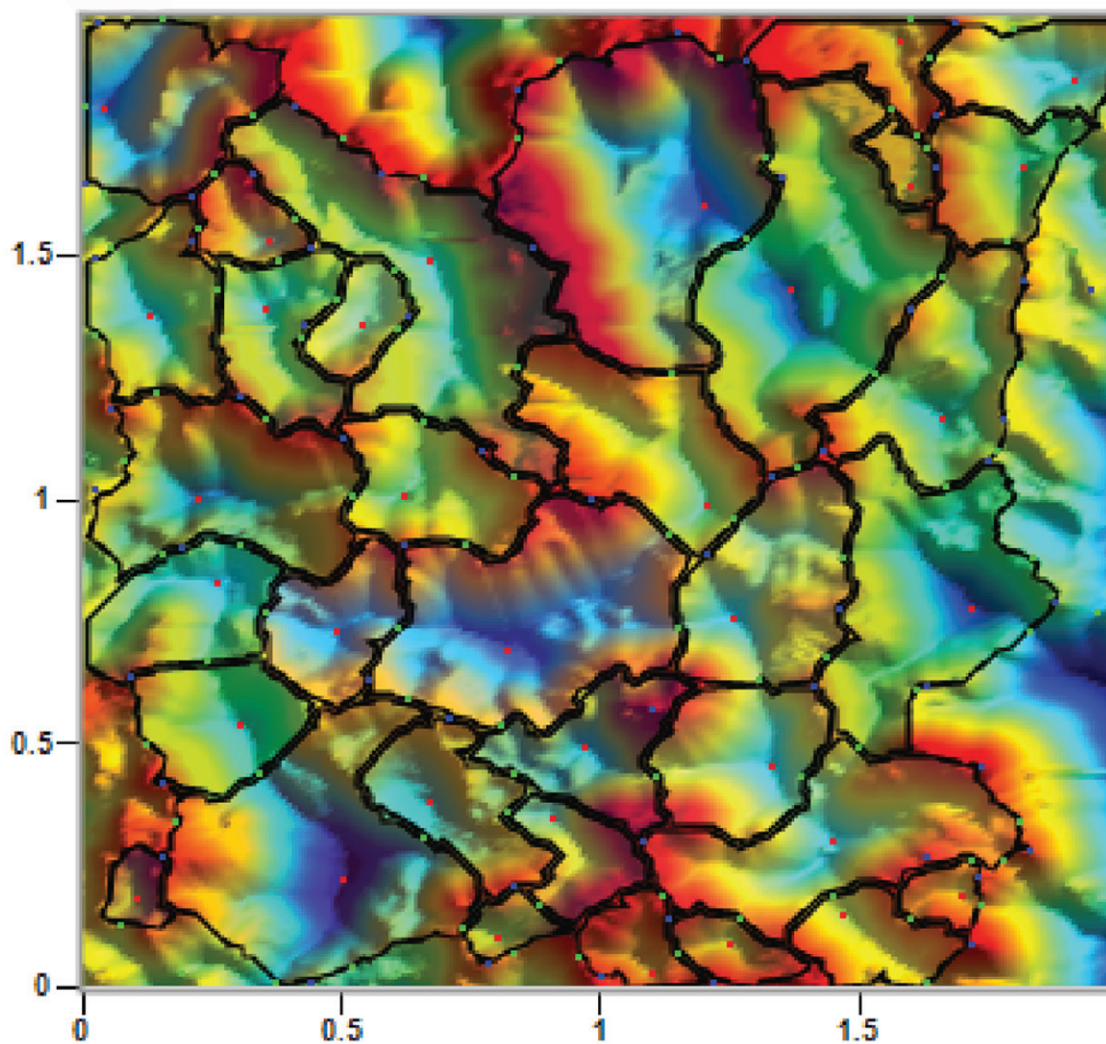

Figure 4 — Example of segmentation of a surface from a grinding wheel with Wolf pruning 5 % total height

.....

Dimensions in millimetres

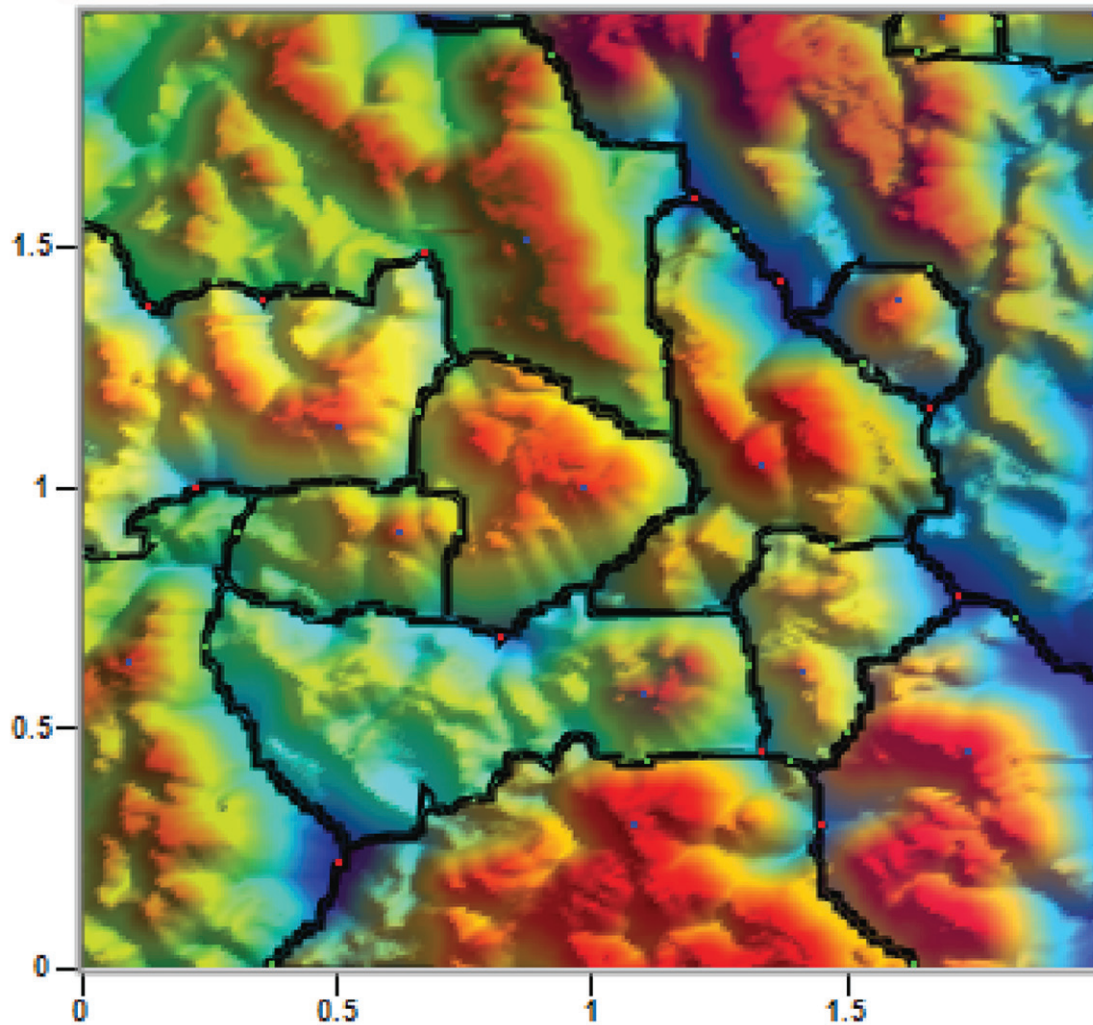

Figure 5 — Example of segmentation of a surface from a grinding wheel with Wolf pruning 15 % total height

In more detail, a surface consists of a set of “events” (3.2.1.1) for example:

- a set of all the extracted points from the surface;
- a set of all the Maxwellian hills;
- a set of all the Maxwellian dales, etc.

Segmentation then consists of:

- a) determining which events are significant, at a particular nesting index, through the use of a segmentation function; and
- b) determining to which significant event each insignificant event should be combined.

Each surface portion, of the segmentation, then consists of a significant event together with all the insignificant events that have been combined with it.

4.2.2 Rules for stable segmentation

A segmentation function consists of splitting the set of “events” into two distinct sets called the significant events and the insignificant events. For the segmentation function to give unique and stable results the segmentation function shall satisfy the following three segmentation properties:

- P1: Each event is allocated to one and only one of these two sets (i.e. the set of significant events and the set of insignificant events).
- P2: If a significant event is removed from the set of events, then the remaining significant events are contained in the new set of significant events.
- P3: If an insignificant event is removed from the set of events, then the same set of significant events is obtained.

It can be shown that all segmentation functions that satisfy these three properties can be mapped one-to-one onto a certain subset of algebraic morphological closing filters.^[13] Algebraic morphological closing filters are widely used in image analysis. They are set functions with the following three defining properties:^[14]

- a) all sets are subsets of their own closings;
- b) a closing of a closing of a set is the closing of the original set;
- c) a closing of a subset is a subset of the closing of the original set.

The particular subsets of the closing filters that the segmentation functions map onto are the closings with the following properties:

If two sets of events give the same closing, then their intersection also gives the same closing

For any closing that satisfies this property, we can map it one-to-one onto a particular segmentation function as follows:

For any set of events, consider the smallest subset of this set that gives the same closing as the original set of events. It can be shown that this particular subset is unique and well defined and corresponds to the set of significant events and its complement, with respect to the set of events, corresponds to the set of insignificant events. The inverse mapping is also well defined.

4.3 Watershed segmentation

4.3.1 General

The watershed method consists of gradually filling insignificant dales with water. The water will eventually flow out of each dale, at a saddle point, into an adjacent dale. If that dale is significant combine the two dales. Otherwise continue to fill the new lake until the water flows into a significant dale; All the filled insignificant dales are then combined with the significant dale. By inverting the landscape so hills become dales, etc., a similar process will establish the combination of insignificant hills to significant hills.

For this part of ISO 16610, the set of events shall consist of areal features and the combination rule shall consist of the watershed method. Segmentation that uses the watershed method as the combination rule is called watershed segmentation.

4.3.2 Change trees

The change tree represents the relationships between contour lines from a surface and its topological features (see [Figure 6](#)). The vertical direction on the change tree represents height. At a given height, all individual contour lines are represented by a point which is part of a line representing that contour line

continuously varying with height. Saddle points are represented by the merging of two or more of these lines into one, peaks and pits are represented by the termination of a line.

NOTE 1 Change trees are a useful way to organize the relationships between topological features in hills and dales and still retain relevant information.

NOTE 2 Kweon and Kanade^[11] introduced the concept of a change tree to describe the connectability of a surface.

NOTE 3 Change trees are one example of a more general topological object called a Reeb Graph.^[15]

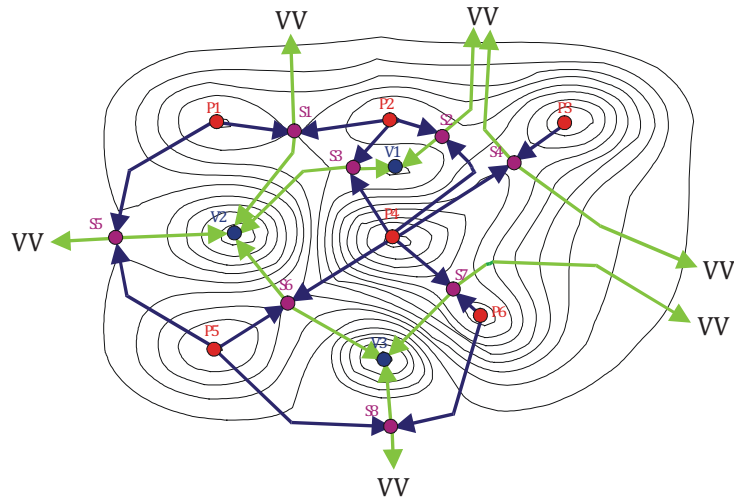

Key

- P peak
- V pit
- S saddle point
- VV virtual valley

Figure 6 — Example of a contour map showing topological features

NOTE 4 There is a close connection between the watershed method and the change tree in that the watershed method can be used to calculate the change tree. Again consider filling a dale gradually with water. The point where the water first flows out of the dale is a saddle point. The pit in the dale is connected to this saddle point in the change tree. Continuing to fill the new lake, the next point where the water flows out of the lake is also a saddle point. Again the line on the change tree, representing the contour of the lake shoreline, will be connected to this saddle point in the change tree. This process can be continued and establishes the connection between the pits, saddle points and the change tree. By inverting the landscape so hills become dales, etc., a similar process will establish the connection between peaks, saddle points and the change tree.

There are at least three change tree types:

- the *Full Change Tree* which represents the relationships between critical points in hills and dales [[Figure 7 a](#)];
- the *Hill Change Tree* which represents the relationships between peaks and saddle points [[Figure 7 b](#)];
- the *Dale Change Tree* which represents the relationships between pits and saddle points [[Figure 7 c](#)].

It should be noted that the dale and hill change trees can be calculated from the full change tree. For the rest of this part of ISO 16610, “change tree” will imply the full change tree.

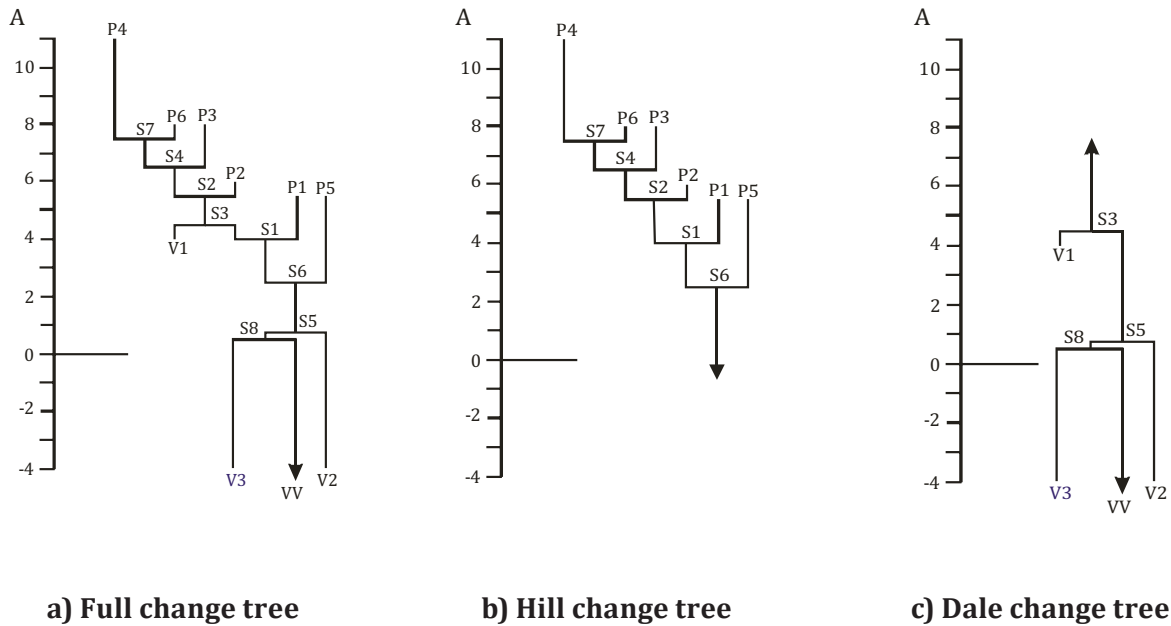

Key

- A height, μm
- P peak
- V pit
- S saddle point
- VV virtual valley

Figure 7 — Change tree types of Figure 6

NOTE 5 The change tree is a convenient representation of the watershed method of combination. It contains all the relevant information to perform the watershed method of combination: for each hill (peak)/dale (pit) the change tree indicates that saddle point where the water would flow over to the adjacent hill/dale. Hence, the watershed method of combination is equivalent to pruning the change tree; for each insignificant hill (peak)/dale(pit) the change tree is pruned at the associated saddle point to which it is connected.

NOTE 6 For extracted data points, watershed merging is equivalent to change tree pruning only if the triangulization of the lattice is assumed to be a continuous surface (i.e. triangular facets).

NOTE 7 In the literature, there are now several publicized references to methods that are analogous to pruning a change tree. [8][9][16] Wolf[13] presented a method which is equivalent to pruning a change tree. This is discussed in 4.4. All of these published pruning methods can be shown to satisfy the three segmentation properties given in 4.2.1.

4.4 Watershed segmentation using Wolf pruning

One first calculates for each peak and pit the height difference between the peak or pit and the adjacent saddle point that they are connected to on the change tree. Wolf’s pruning method consists of finding the peak or pit with smallest height difference and combining with the adjacent saddle point on the change tree. The other peak or pit also connected to this saddle point is now connected to another saddle and so its height difference is adjusted to reflect this.

The process is then repeated with that peak or pit with the smallest height difference to its adjacent saddle point on the change tree being eliminated until, some threshold is reached. This threshold could be when all remaining height differences are above a fixed value (usually a given percentage of S_z) or

alternative when a fixed number of peaks or pits are left. It is easily proved that both criteria lead to a segmentation function that satisfies the three required properties given in 4.2.1.

Using the change tree given in Figure 4, P6 to S7, P2 to S2 and V1 to S3 all have a local peak/pit height less than 0,5 μm . Pruning these leads to the change tree given in Figure 8.

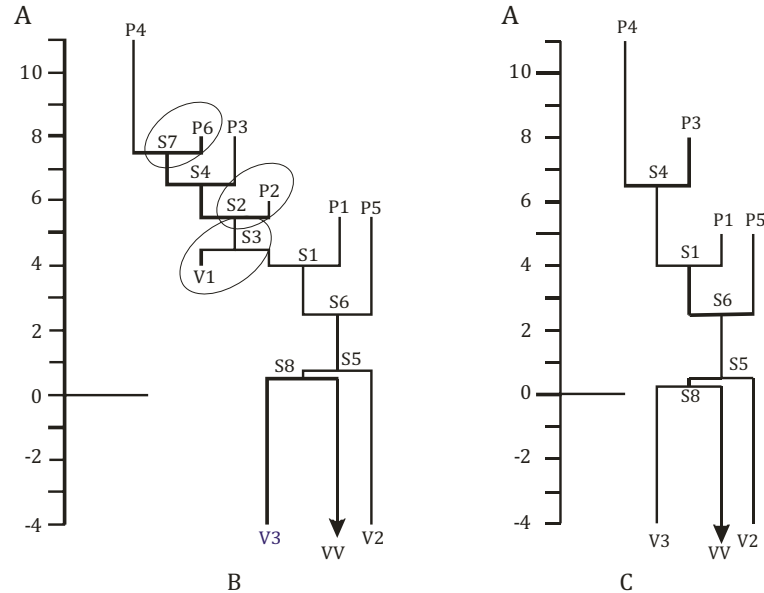

Key

- A height, μm
- P peak
- V pit
- S saddle point
- VV virtual valley

Figure 8 — Wolf pruning of Figure 4

The following is an outline algorithm for Wolf pruning from a full change tree. This algorithm can easily be modified for dale or hill combination and so these cases will not be discussed here. The simplified algorithm presented here assumes that the virtual pit condition has been applied.

- Step 1** Assuming the virtual pit condition find all the Maxwellian hills and dales and generate the full change tree.
- Step 2** From the remaining hills and dales find the peak/pit (called the candidate peak/pit) associated with each hill/dale with the smallest local peak/pit height.
- Step 3** If this local peak/pit height is larger than the given threshold, stop. Otherwise, go to step 4.
- Step 4** Prune the candidate peak/pit from the change tree at its associated saddle point to which it is connected to in the change tree (i.e. combine the insignificant hill/dale with the associated significant hill/dale).
- Step 5** Go to step 2.

Other useful information concerning segmentation can be found in Annex A. Examples of Wolf pruning can be found in Annex B.

5 General information

The filtration master plan is given in [Annex C](#). The concept diagrams for this document are given in [Annex D](#) and the relationship between this document and the GPS master plan is given in [Annex E](#).

Segmentation filters conforming to this part of ISO 16610 are designated **FAMSW**.

Annex A (informative)

Additional information about segmentation

A.1 Maxwellian hills and dales

More than a hundred years ago, Maxwell^[14] proposed dividing a landscape into regions consisting of hills and regions consisting of dales. A Maxwellian hill is an area from which maximum upward paths lead to one particular peak, and a Maxwellian dale is an area from which maximum downward paths lead to one particular pit. By definition, the boundaries between hills are course lines (watercourses), and the boundaries between dales are ridge lines (watershed lines). Maxwell was able to demonstrate that ridge and course lines are maximum upward and downward paths emanating from saddle points and terminating at peaks and pits. Recently, the Maxwellian dale (watershed lines) has emerged as the primary tool of mathematical morphology of image segmentation as preparation for pattern recognition.

A.2 Hills and dales

Unfortunately, segmenting a surface or image into Maxwellian dales is often disappointing as the surface/image is over-segmented into a large number of insignificant tiny, shallow dales rather than a few significant large deep dales. What is required is to merge the insignificant dales into larger significant dales.

It is proposed to extend Maxwell's definitions and to define a dale as consisting of a single dominant pit surrounded by a ring of ridge lines connecting peaks and saddle points and to define a hill as consisting of a single dominant peak surrounded by a ring of course lines connecting pits and saddle points. Within a dale or hill there may be other pits/peaks but they will all be insignificant compared to the dominant pit/peak.

The dale is the areal equivalent of the profile motif (see ISO 12085). The hill is also a useful complementary concept. Like the profile motif, several types of surface specific points and lines characterize hills and dales. These include the critical points:

- peaks, pits and saddles points

and critical lines:

- ridge lines, course lines.

A.3 Edge effects

It is also important to consider edge effects. Ockham's Razor (*non sunt multiplicanda entia praeter necessitatem* – entities are not to be multiplied beyond necessity) is used to extend contour lines outside the area of interest in such a way that a minimum number of new critical points are created. Ockham's Razor leads to two possible solutions called "the virtual pit" and "the virtual peak", each being the dual of each other. The concept of the virtual pit is adopted.^[16] A virtual pit is assumed to be a point of height minus infinity to which all the boundary points are connected. (A virtual peak is assumed to be a point of infinite height to which all the boundary points are connected.)

Annex B (informative)

Wolf pruning examples

B.1 Example 1 — Grinding wheel (identifying active grains)

The cutting edges on a grinding wheel are geometrically undefined in location and shape. In order to ascertain the qualitative measurement of cutting edges it is necessary to develop techniques to identify the individual cutting edges from topographic data ([Figure B.1](#)).

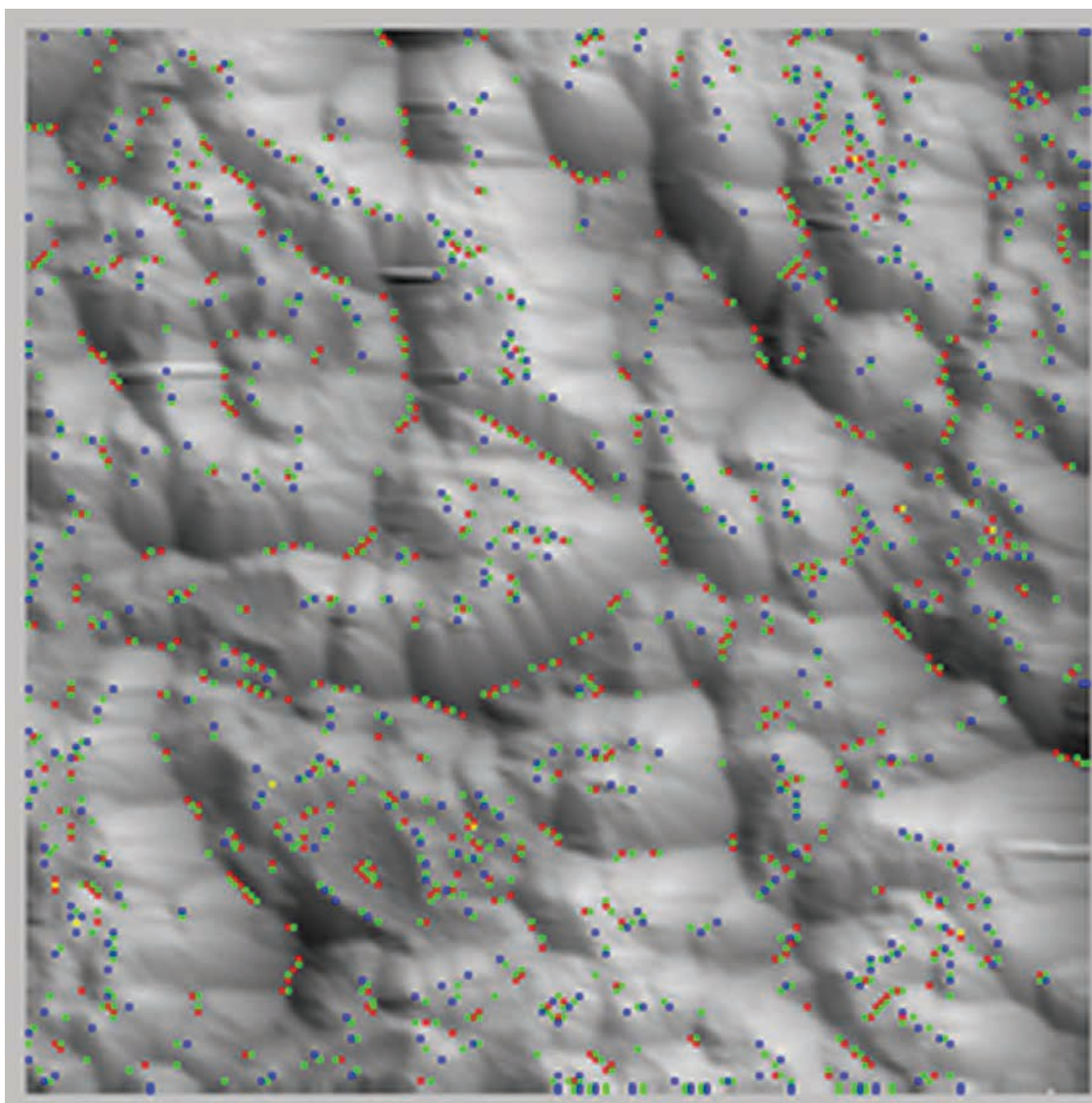

a) Initial critical points

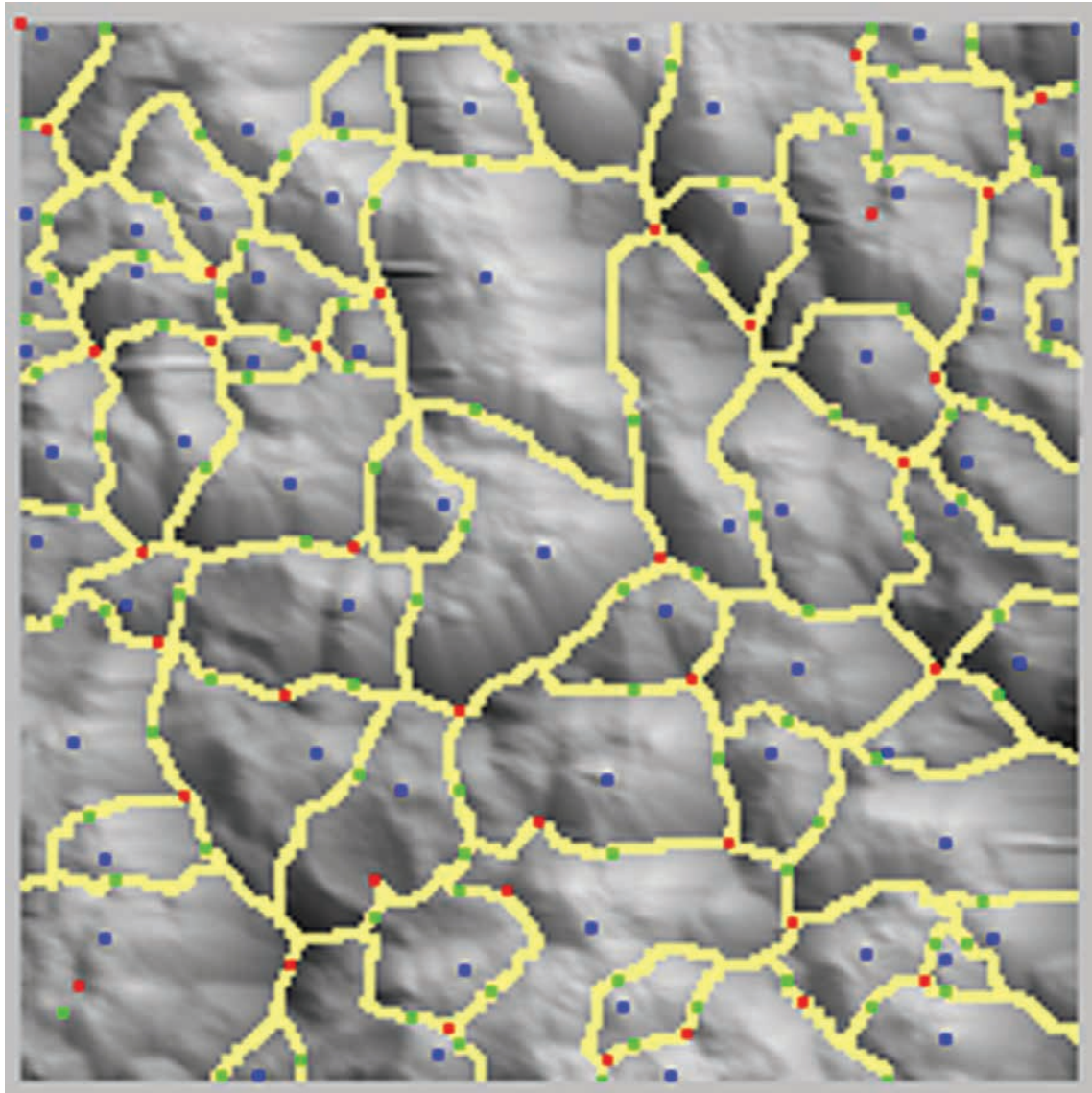

b) Hill segmentation after Wolf pruning

Figure B.1 — Grit from a grinding wheel 0,5 mm × 0,5mm (a) (b)

Blunt and Ebdon^[18] describe an approach based on using local peaks to count the number of cutting edges. Unfortunately, using the number of local peaks produces an overestimate [409 peaks in [Figure B.1 a\)](#)]. Blunt and Ebdon recognized this counting problem and suggested sub-sampling the measured data to achieve the “correct count”. The optimal sub-sampling corresponds to approximately one peak on each grinding wheel grain. Hence changing the grain size changes the distance of the optimal sub-sampling. Owing to the non-uniform packing and grain shapes this may vary considerably within a given grinding wheel.

Wolf pruning at 5 % (i.e. Five % of the peak-to-valley of the data) produces the correct count for all grain sizes in these examples. For [Figure B.1 b\)](#), this produces 60 peaks. Wolf pruning has the added advantage that the significant peak in each segment is given allowing further analysis. For example, a height analysis can distinguish which of these peak could be active i.e. come into contact with the workpiece. Thus, Wolf pruning segmentation can help in the characterization of grinding wheels.

B.2 Example 2 — Car body panel

The sheet steel used in car body panels is deliberately textured to allow paint to adhere to the metal and allow for lubrication in metal forming. This texturing is added to the final rollers, in the rolling mill, to impart the texture onto the sheet steel. In the example given in [Figure B.2](#), this texturing consists of a pattern of circular moats in a hexagonal pattern. In order to control the production process a sample of the sheet steel is measured and inspected [[Figure B.2 a](#)]. Currently, this inspection is carried out by eye. Wolf pruning at 12 % [[Figure B.2 b](#)] allows identification of the individual moats for further characterization in these examples. Thus, Wolf pruning segmentation allows the inspection process to be automated.

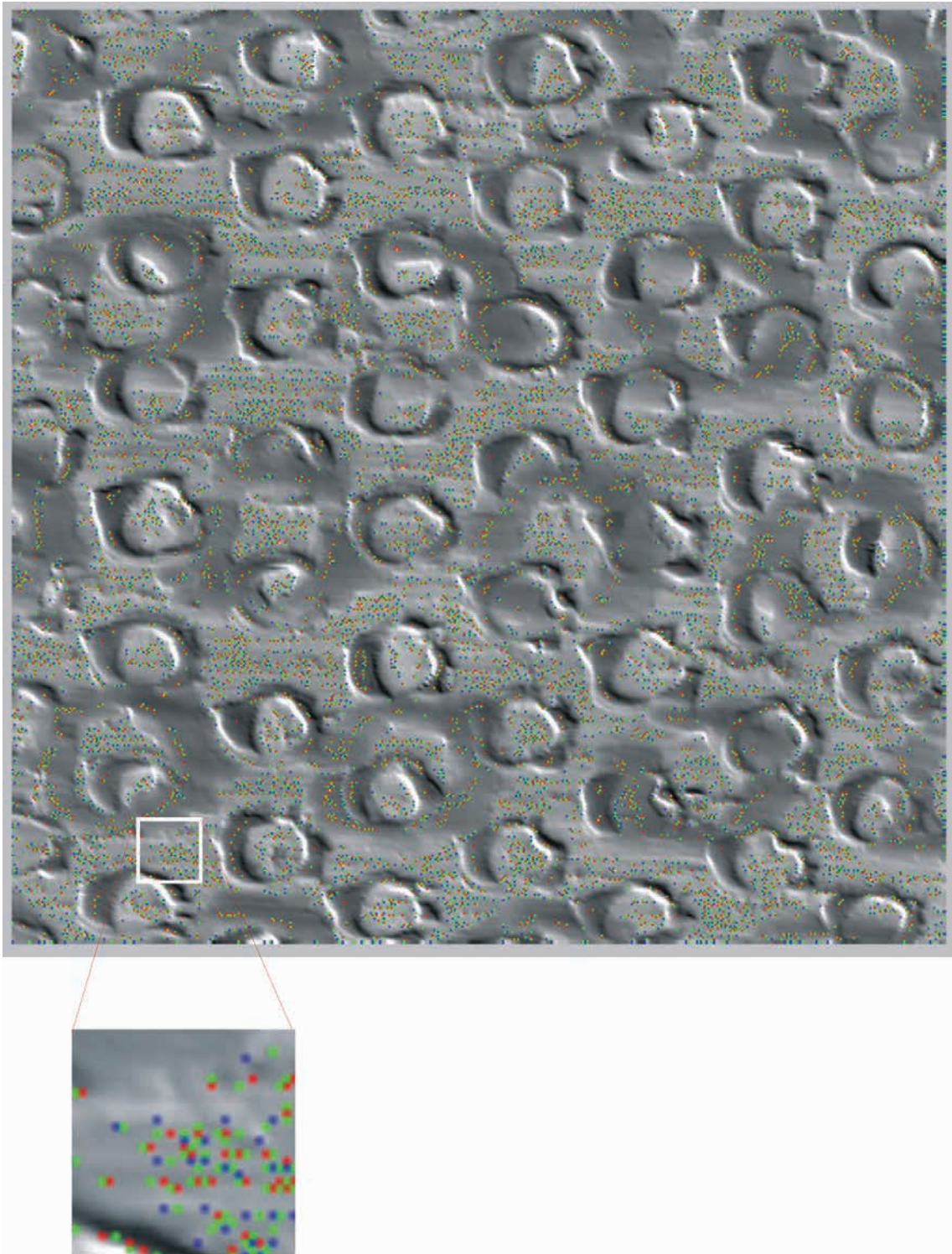

a) Initial critical points

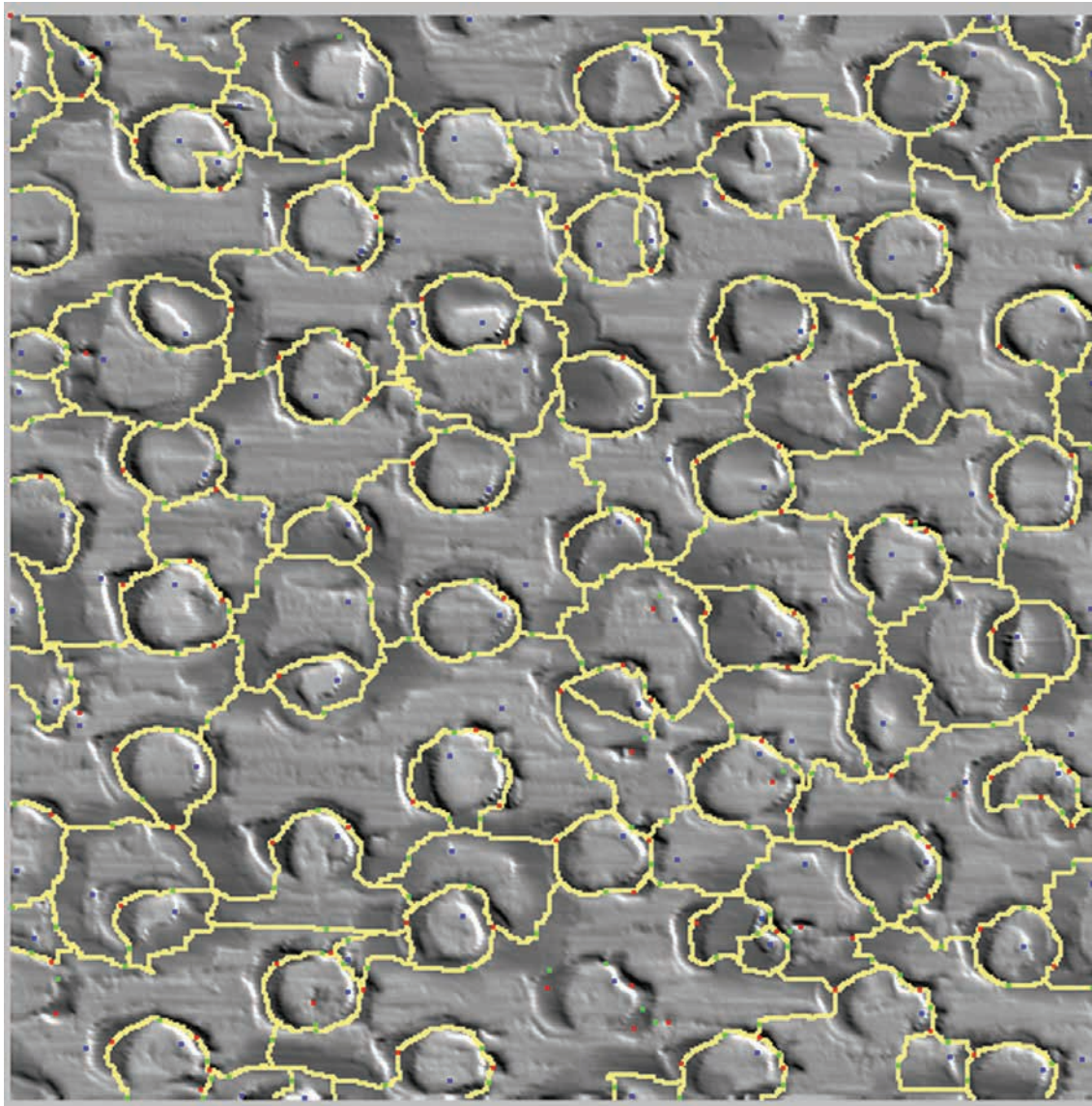

b) Hill segmentation after Wolf pruning

Figure B.2 — Car body panel before paint 1 mm × 1mm

Annex C (informative)

Relationship to the filtration matrix model

C.1 General

For full details about the filtration matrix model, see ISO 16610-1.

C.2 Position in the filtration matrix model

This document is a particular filter document in the column “Areal Filters Morphological” (see [Figure C.1](#)).

X	FILTERS : ISO 16610 series					
General	Part 1					
X	Profile Filters			Areal Filters		
Fundamental	Part 11			Part 12		
X	Linear	Robust	Morphological	Linear	Robust	Morphological
Basic Concepts	Part 20	Part 30	Part 40	Part 60	Part 70	Part 80
Particular Filters	Parts 21-25	Parts 31-35	Parts 41-45	Parts 61-65	Parts 71-75	Parts 81-85
How to Filter	Parts 26-28	Parts 36-38	Parts 46-48	Parts 66-68	Parts 76-78	Parts 86-88
Multiresolution	Part 29	Part 39	Part 49	Part 69	Part 79	Part 89

Figure C.1 — Relationship to the filtration matrix model

Annex D (informative)

Concept diagrams

D.1 Geometrical features

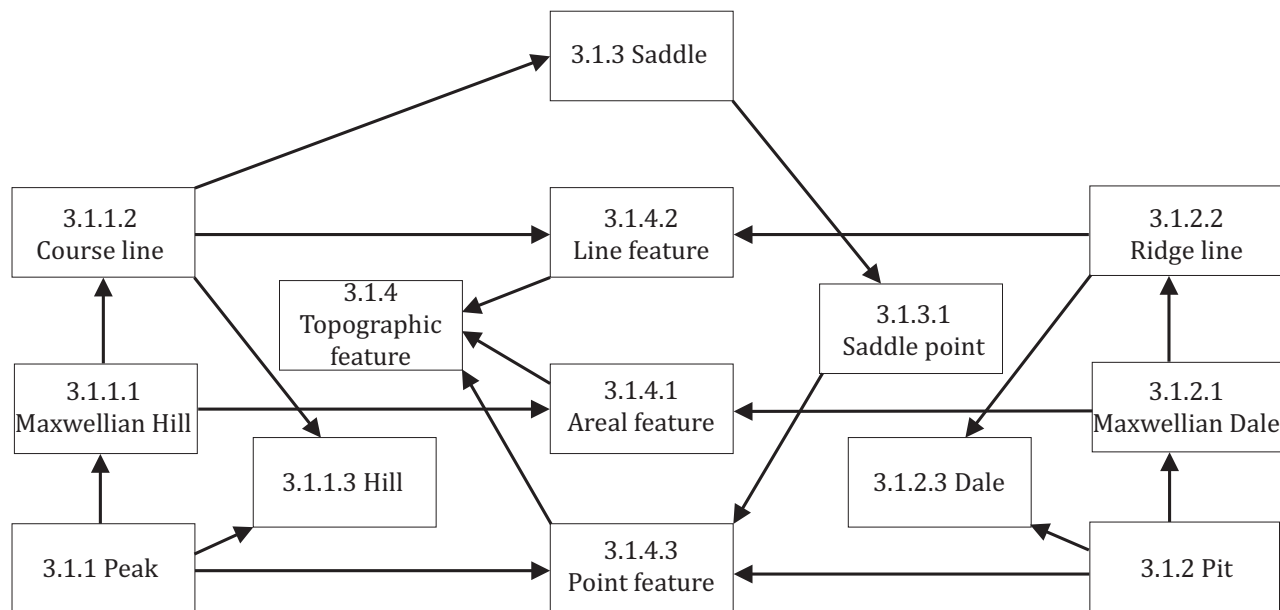

Figure D.1 — Concept diagram for geometrical features

D.2 Segmentation

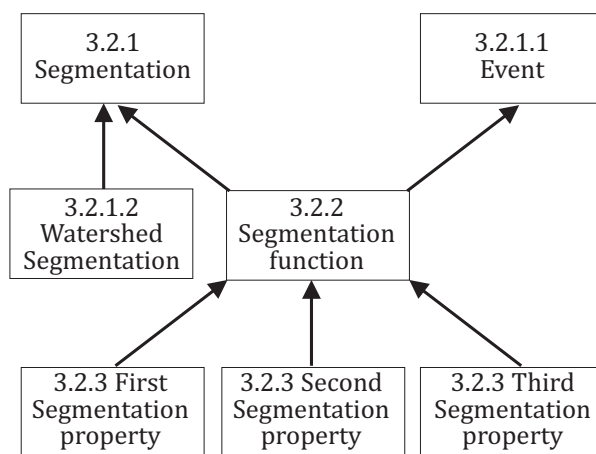

Figure D.2 — Concept diagram for segmentation

D.3 Pruning

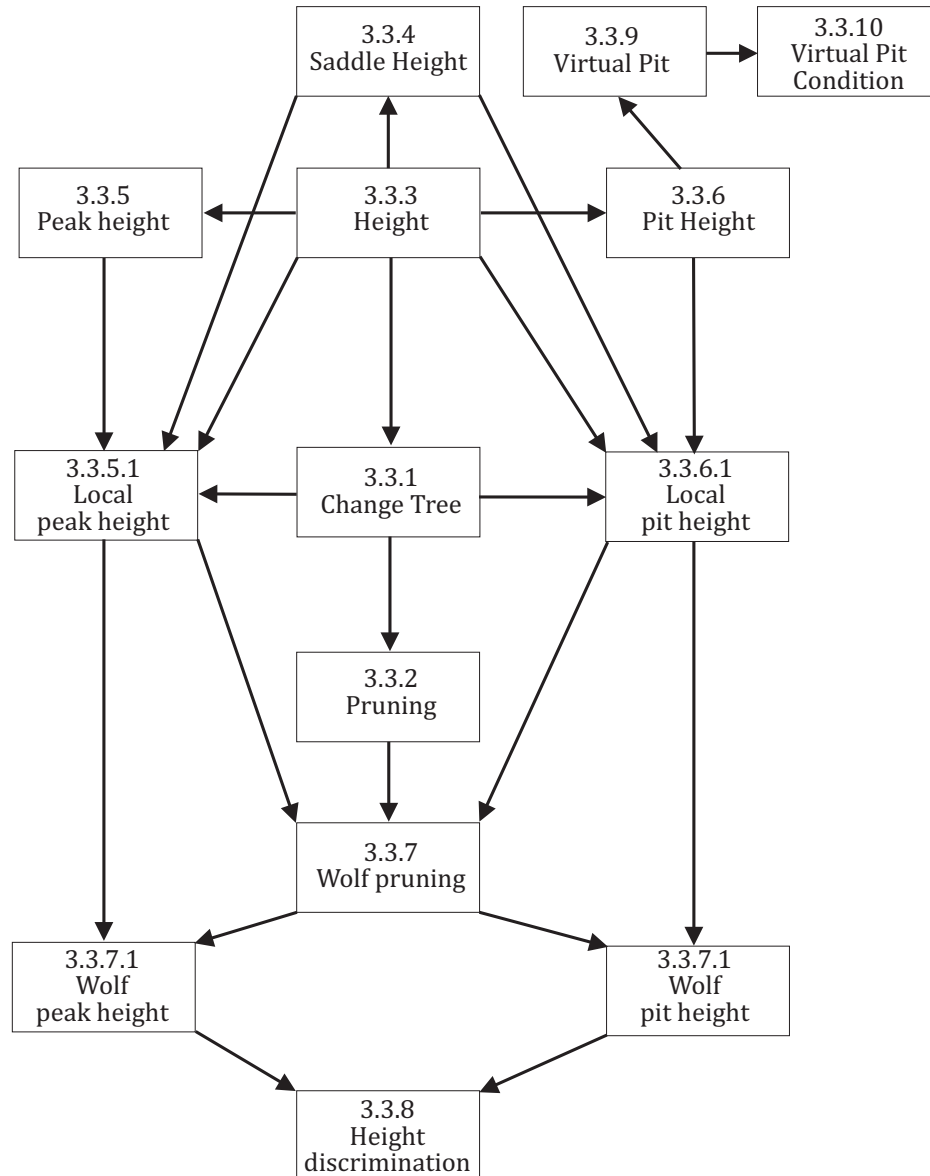

Figure D.3 — Concept diagram for pruning

Annex E (informative)

Relation to the GPS matrix model

E.1 General

For full details about the GPS matrix model, see ISO 14638.

The ISO/GPS Masterplan given in ISO 14638 gives an overview of the ISO/GPS system of which this document is a part. The fundamental rules of ISO/GPS given in ISO 8015 apply to this document and the default decision rules given in ISO 14253-1 apply to specifications made in accordance with this document unless otherwise indicated.

E.2 Information about the document and its use

This part of ISO 16610 develops the terminology and concepts for areal segmentation.

E.3 Position in the GPS matrix model

This part of ISO 16610 is a general GPS standard, which influences the feature characteristics chain link in the general GPS matrix structure, as graphically illustrated in [Table E.1](#).

Table E.1 — Fundamental and general ISO GPS standards matrix

	Chain links						
	Symbols and indications	Tolerance zones and parameters	Feature characteristics	Comparison and compliance	Measurement	Measurement equipment	Calibration
	(Former chain link 1)	(Former chain link 2)	(Former chain link 3)		(Former chain link 4)	(Former chain link 5)	(Former chain link 6)
Size			•				
Distance			•				
Radius			•				
Angle			•				
Form			•				
Orientation			•				
Location			•				
Run-out			•				
Profile surface texture			•				
Areal surface texture			•				
Surface imperfections			•				
Edges			•				

E.4 Related standards

The related standards are those of the chains of standards indicated in [Table E.1](#).

Bibliography

- [1] ISO 8015, *Geometrical product specifications (GPS) — Fundamentals — Concepts, principles and rules*.
- [2] ISO 12085:1996, *Geometrical Product Specifications (GPS) — Surface texture: Profile method — Motif parameters*
- [3] ISO 14253-1, *Geometrical Product Specifications (GPS) — Inspection by measurement of workpieces and measuring equipment — Part 1: Decision rules for proving conformance or non-conformance with specifications*
- [4] ISO 14638, *Geometrical product specifications (GPS) — Masterplan*
- [5] ISO 25178-2:2012, *Geometrical product specifications (GPS) — Surface texture: Areal — Part 2: Terms, definitions and surface texture parameters*.
- [6] ISO 25178-3, *Geometrical product specifications (GPS) — Surface texture: Areal — Part 3: Specification operators*
- [7] ISO/IEC Guide 98-3:2008, *Uncertainty of measurement — Part 3: Guide to the expression of uncertainty in measurement (GUM:1995)*
- [8] ISO/IEC Guide 99:2007, *International vocabulary of metrology — Basic and general concepts and associated terms (VIM)*

References — Fundaments

- [9] SCOTT P.J. Pattern Analysis and Metrology: The extraction of stable features from observable measurements. *Proc. R. Soc. Lond. A.* 2004, **460** pp. 2845–2864
- [10] SERRA J., & VINCENT L. An Overview of Morphological Filtering, Circuits Systems. *Signal Process.* 1992, **11** (1) pp. 47–108
- [11] KWEON I.S., & KANADE T. Extracting topographic terrain features from elevation maps. *CVGIP: image understanding*, 1994, **59**(2), pp. 171-182
- [12] TAKAHASHI S. et al. Algorithms for extracting correct critical points and constructing topological graphs from discrete geographical elevation data. *Comput. Graph. Forum.* 1995, **14** (3) pp. C181–C192
- [13] WOLF G.W. A Fortran subroutine for cartographic generalization. *Comput. Geosci.* 1991, **17** (10) pp. 1359–1381
- [14] MAXWELL J.C. On hills and dales. *The London, Edinburgh, and Dublin Phil. Mag. and J. Sci., Series 4.* 1870, **40** pp. 421–425

References — GPS Origins

- [15] BLEAU A., & LEON L.J. Watershed-based segmentation and region merging. *Comput. Vis. Image Underst.* 2000, **77** pp. 317–370
- [16] BARRÉ F., & LOPEZ J. Watershed lines and catchment basins: a new 3D-motif method. *Int. J. Mach. Tools Manuf.* 2000, **40** pp. 1171–1184
- [17] SCOTT P.J. Foundations of topological characterization of surface texture. *Int. J. Mach. Tools Manuf.* 1998, **38** (5-6) pp. 559–566

References — GPS Applications

- [18] BLUNT L., & EBDON S. The application of three-dimensional surface measurement techniques to characterizing grinding wheel topography. *Int. J. Mach. Tools Manuf.* 1996, **36** pp. 1207–1226

