**Rotary shaft lip-type seals incorporating
thermoplastic sealing elements —**

**Part 5:
Identification of visual imperfections**

*Bagues d'étanchéité à lèvres pour arbres tournants incorporant des
éléments d'étanchéité thermoplastiques —*

Partie 5: Identification des imperfections visuelles





COPYRIGHT PROTECTED DOCUMENT

© ISO 2011

All rights reserved. Unless otherwise specified, no part of this publication may be reproduced or utilized in any form or by any means, electronic or mechanical, including photocopying and microfilm, without permission in writing from either ISO at the address below or ISO's member body in the country of the requester.

ISO copyright office
Case postale 56 • CH-1211 Geneva 20
Tel. + 41 22 749 01 11
Fax + 41 22 749 09 47
E-mail copyright@iso.org
Web www.iso.org

Published in Switzerland

Contents

Page

Foreword	iv
Introduction.....	v
1 Scope	1
2 Normative references	1
3 Terms and definitions	1
4 Characteristic imperfections	1
4.1 Definition of sealing lip critical area	1
4.2 Type and name of imperfections	1
4.3 Visual imperfections on seals with additional components	2
4.3.1 Outer circumference portion	2
4.3.2 Protection lip.....	2
5 Identification statement (Reference to this part of ISO 16589).....	2
Bibliography.....	14

Foreword

ISO (the International Organization for Standardization) is a worldwide federation of national standards bodies (ISO member bodies). The work of preparing International Standards is normally carried out through ISO technical committees. Each member body interested in a subject for which a technical committee has been established has the right to be represented on that committee. International organizations, governmental and non-governmental, in liaison with ISO, also take part in the work. ISO collaborates closely with the International Electrotechnical Commission (IEC) on all matters of electrotechnical standardization.

International Standards are drafted in accordance with the rules given in the ISO/IEC Directives, Part 2.

The main task of technical committees is to prepare International Standards. Draft International Standards adopted by the technical committees are circulated to the member bodies for voting. Publication as an International Standard requires approval by at least 75 % of the member bodies casting a vote.

Attention is drawn to the possibility that some of the elements of this document may be the subject of patent rights. ISO shall not be held responsible for identifying any or all such patent rights.

ISO 16589-5 was prepared by Technical Committee ISO/TC 131, *Fluid power systems*, Subcommittee SC 7, *Sealing devices*.

This second edition cancels and replaces the first edition (ISO 16589-5:2001), which has been technically revised.

ISO 16589 consists of the following parts, under the general title *Rotary shaft lip-type seals incorporating thermoplastic sealing elements*:

- *Part 1: Nominal dimensions and tolerances*
- *Part 2: Vocabulary*
- *Part 3: Storage, handling and installation*
- *Part 4: Performance test procedures*
- *Part 5: Identification of visual imperfections*

Introduction

Rotary shaft lip-type seals are used to retain fluid in equipment where the differential pressure is relatively low. Typically, the shaft rotates and the housing is stationary, although in some applications the shaft is stationary and the housing rotates.

Dynamic sealing is normally the result of a designed interference fit between the shaft and a flexible element incorporated in the seal.

Similarly, a designed interference fit between the outside diameter of the seal and the diameter of the housing bore retains the seal and prevents static leakage.

Careful storage and handling and proper installation of all seals are necessary to avoid hazards, both prior to and during installation, which would adversely affect service life.

Rotary shaft lip-type seals incorporating thermoplastic sealing elements —

Part 5: Identification of visual imperfections

1 Scope

ISO 16589 specifies seals utilizing sealing elements manufactured from suitably formulated compounds based on thermoplastic materials, such as polytetrafluoroethylene (PTFE). They are considered suitable for use under low pressure conditions.

This part of ISO 16589 defines and classifies typical surface imperfections that could impair the function of the seals, and is intended as a convenience for purchasers and manufacturers in their discussions concerning the importance of these imperfections in different applications.

NOTE ISO 16589 is complementary to ISO 6194, which covers seals incorporating elastomeric sealing elements.

2 Normative references

The following referenced documents are indispensable for the application of this document. For dated references, only the edition cited applies. For undated references, the latest edition of the referenced document (including any amendments) applies.

ISO 5598, *Fluid power systems and components — Vocabulary*

ISO 16589-2, *Rotary shaft lip-type seals incorporating thermoplastic sealing elements — Part 2: Vocabulary*

3 Terms and definitions

For the purposes of this document, the terms and definitions given in ISO 5598 and ISO 16589-2 apply.

4 Characteristic imperfections

4.1 Definition of sealing lip critical area

The sealing lip critical area is defined in Figure 1.

4.2 Type and name of imperfections

Some typical imperfections are shown in Figures 2 to 20, and listed in Tables 1 and 2.

4.3 Visual imperfections on seals with additional components

4.3.1 Outer circumference portion

The imperfections on the outer circumference portion are the following:

- a) scratch;
- b) incorrect chamfer;
- c) incomplete bond.

4.3.2 Protection lip

The imperfections on the protection lip are the following:

- a) tear;
- b) cut or nick;
- c) non-fill;
- d) flash.

5 Identification statement (Reference to this part of ISO 16589)

Manufacturers are strongly recommended to use the following statement in test reports, catalogues and sales literature when electing to comply with this part of ISO 16589:

“Visual imperfection identification is in accordance with ISO 16589-5, Rotary shaft lip-type seals incorporating thermoplastic sealing elements — Part 5: Identification of visual imperfections.”

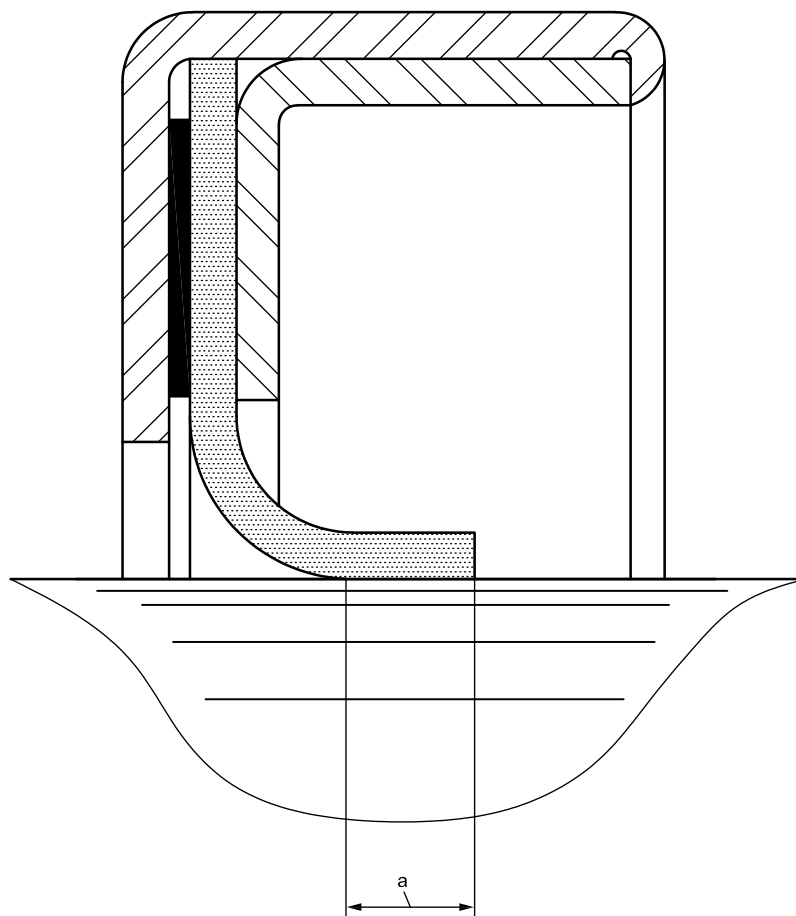

a Sealing lip critical area.

NOTE In cases of wear, imperfections in the sealing lip critical area can impair the function of the rotary shaft lip-type seal during its lifetime. This dimension can vary according to the design standards of individual manufacturers.

Figure 1 — Sealing lip critical area

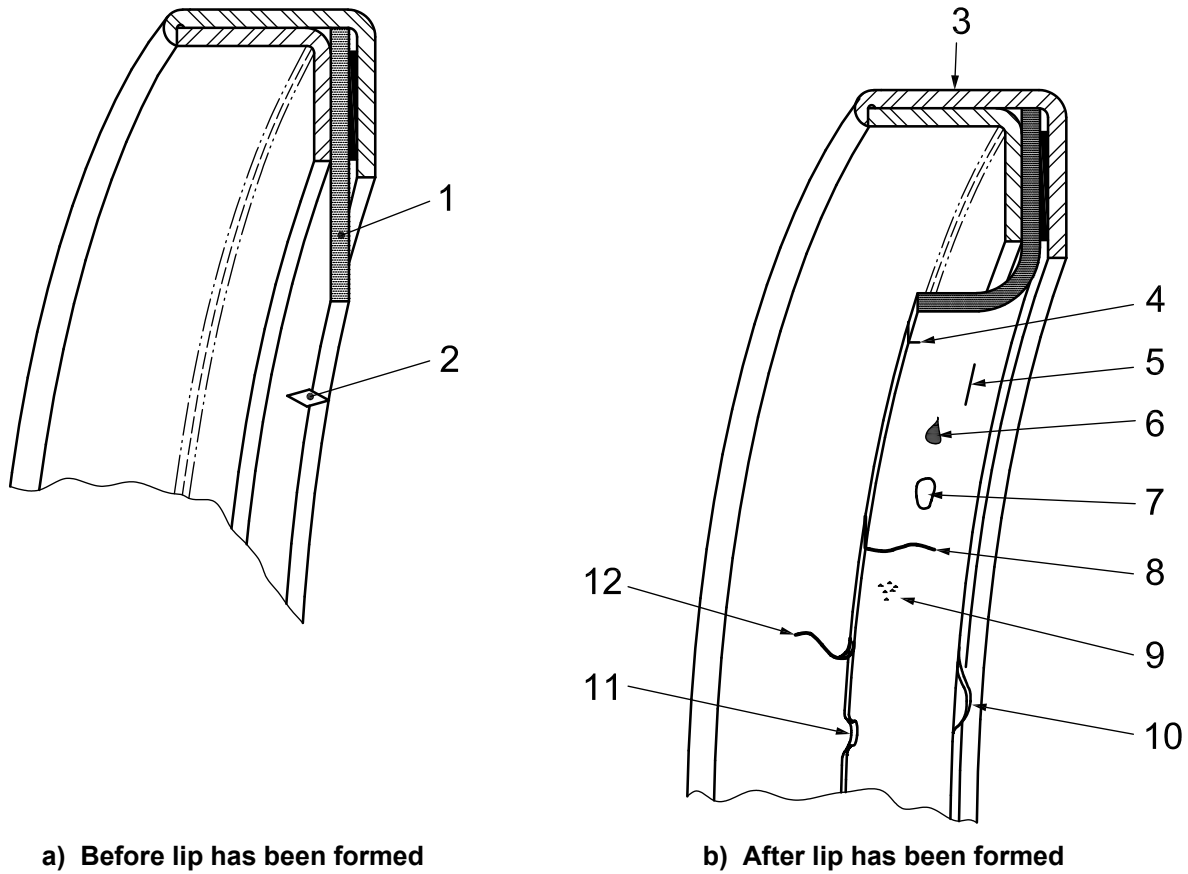

Figure 2 — Typical imperfections

Table 1 — Typical visual imperfections

Figure 2 item number	Description	Detail illustration
1	Sealing element reversal (hydrodynamic aid on the inside)	Figure 4
2	Nicks	Figure 5
3	Uneven outer diameter sealant	—
4	Cut	Figure 6
5	Crack	Figure 7
6	Inclusion	Figure 8
7	Polymer window	Figure 9
8	Tear	Figure 10
9	Filler projections	Figure 11
10	Gasket extrusion	Figure 12
11	Sealing lip inversion	Figure 13
12	Incomplete trim or folded flash	Figure 14

Table 2 — Typical miscellaneous imperfections

Description	Detail illustration
Incorrect hydrodynamic aid feature	Figure 15
Rough surface finish, sealing element	Figure 16
Incorrect roll-over of retaining flange	Figure 17
Missing gasket	Figure 18
Lip eccentric to outer case diameter (incorrectly formed on mandrel)	Figure 19
Lip eccentric to outer case diameter (outer diameter of sealing element undersized)	Figure 20

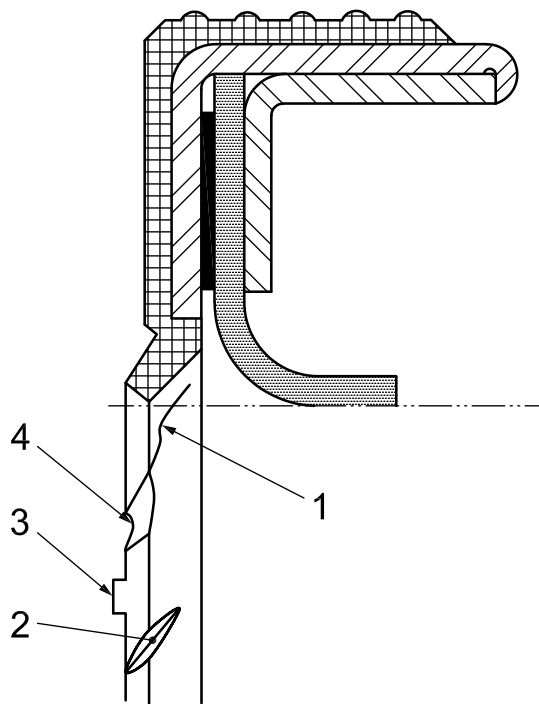
**Key**

- 1 tear
- 2 cut or nick
- 3 flash
- 4 non-fill

Figure 3 — Protection lip imperfections (rubber-covered and elastomeric protection lip)

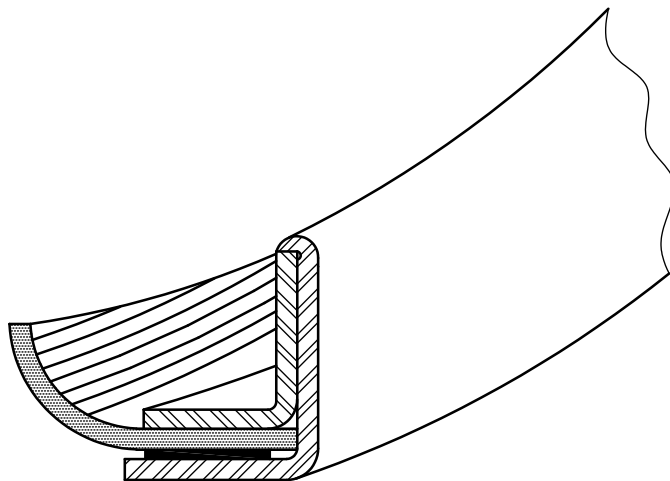

Figure 4 — Sealing element reversal (hydrodynamic aid on the inside)

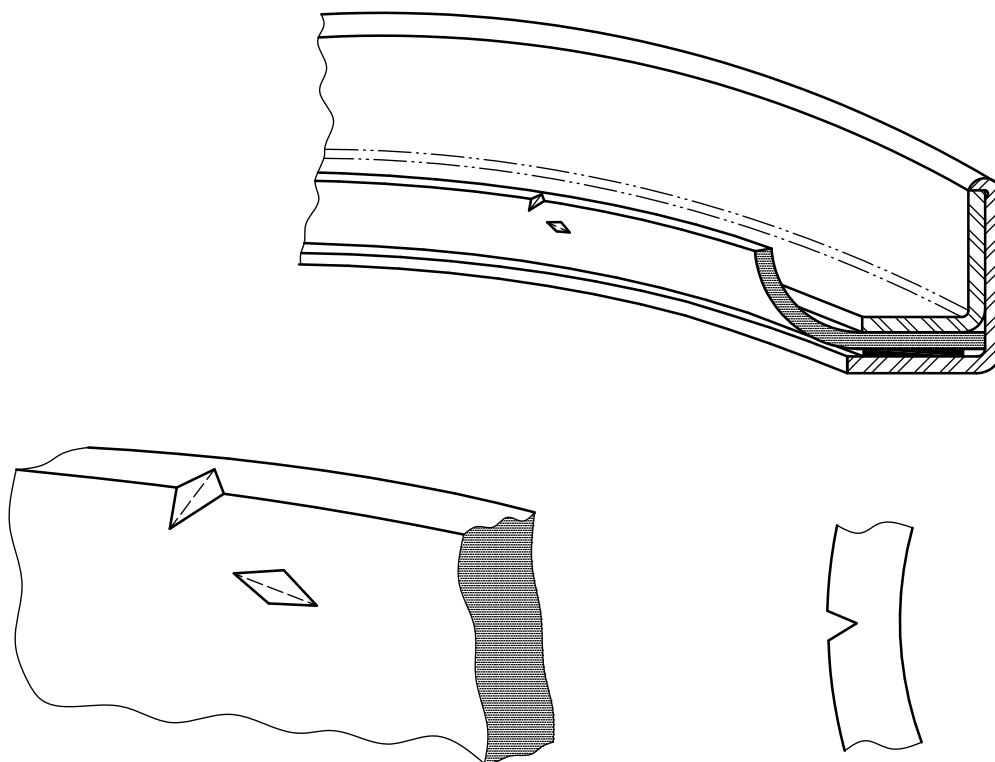

Figure 5 — Nicks

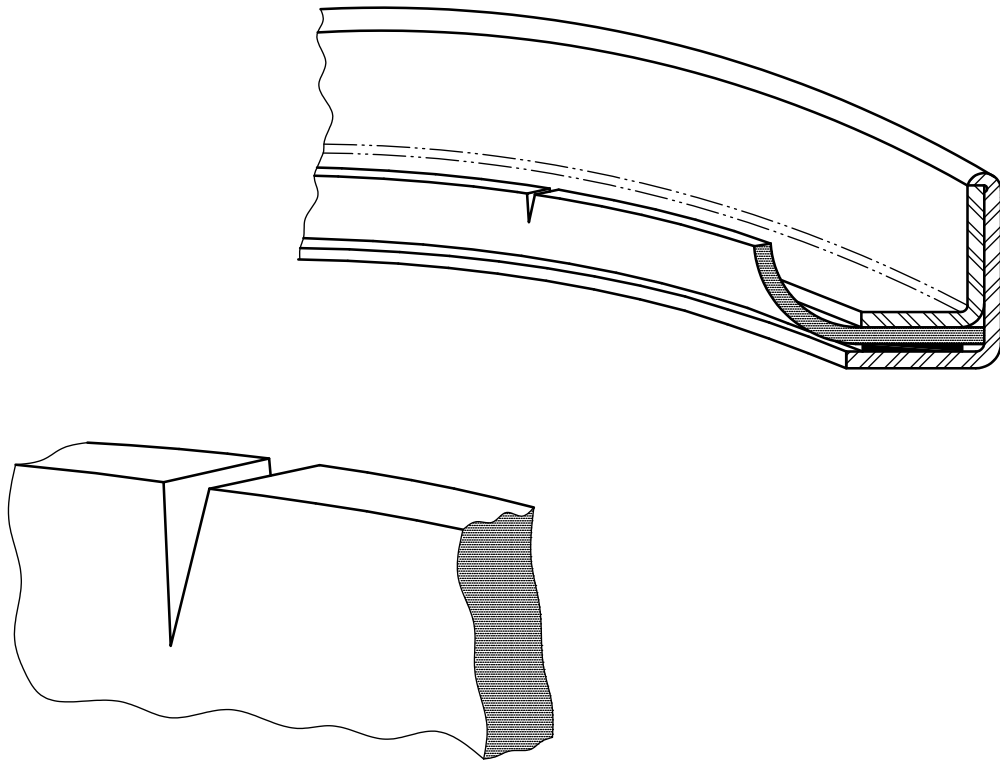

Figure 6 — Cut

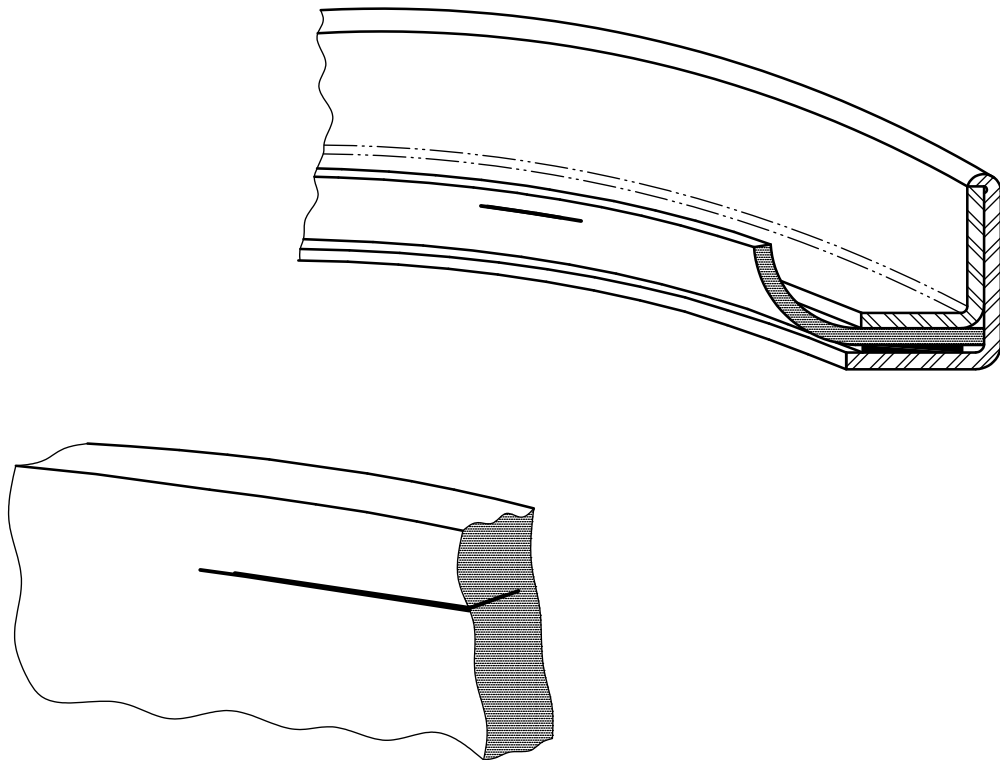

Figure 7 — Crack

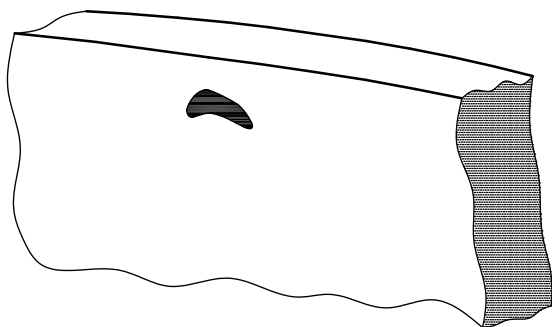
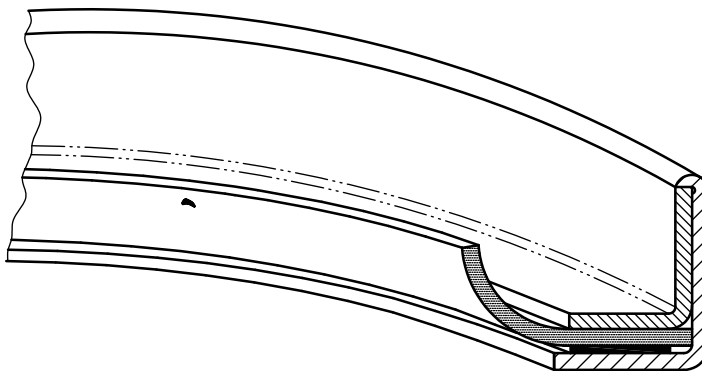

Figure 8 — Inclusion

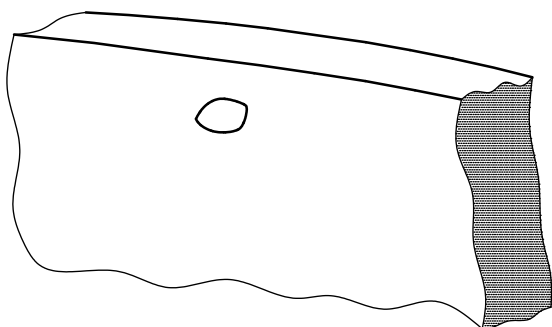
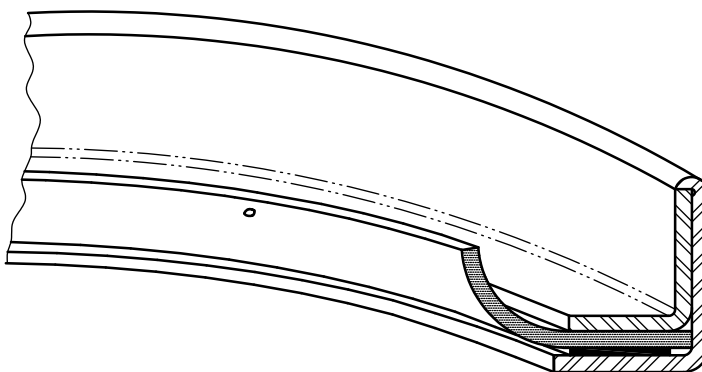

Figure 9 — Polymer window

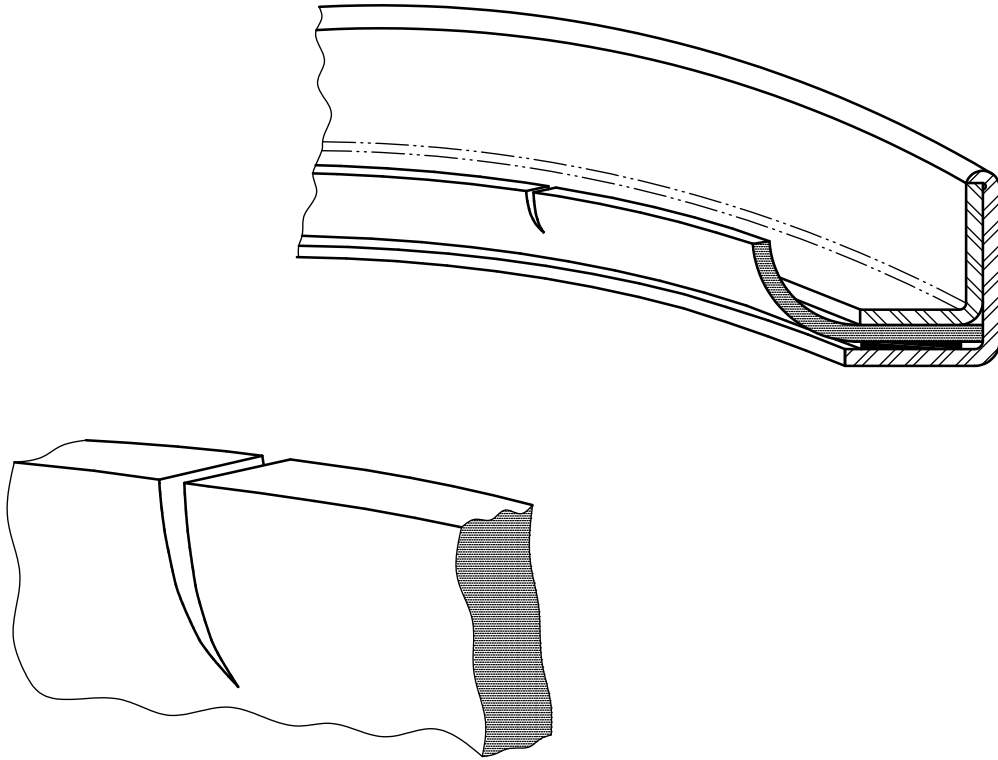

Figure 10 — Tear

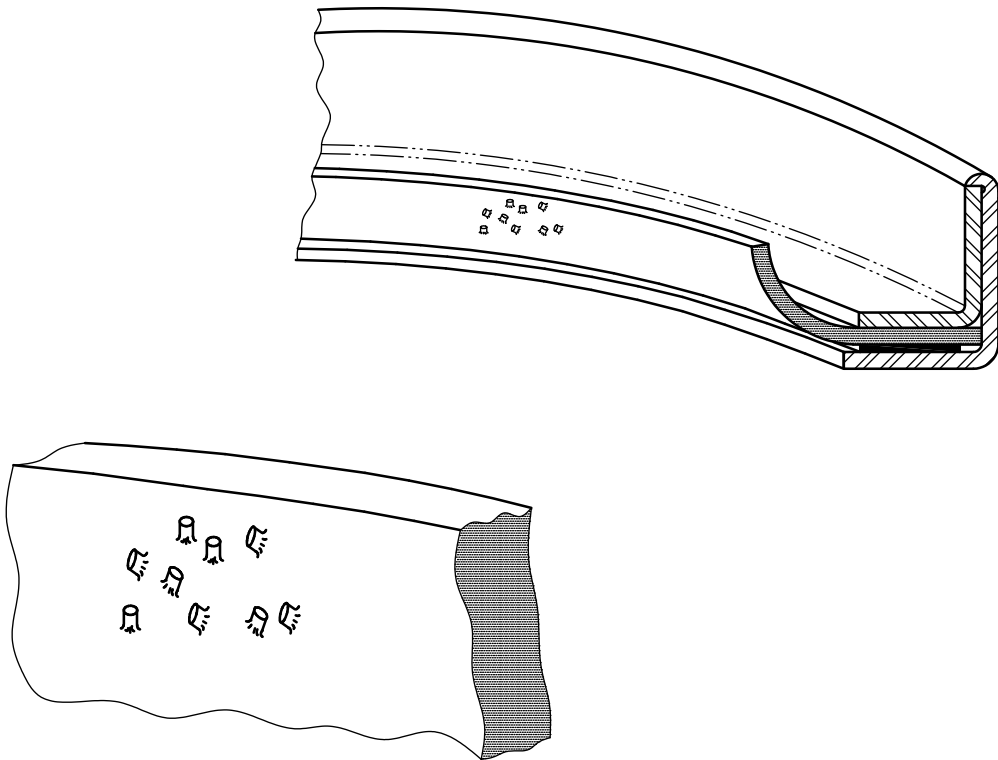

Figure 11 — Filler projections

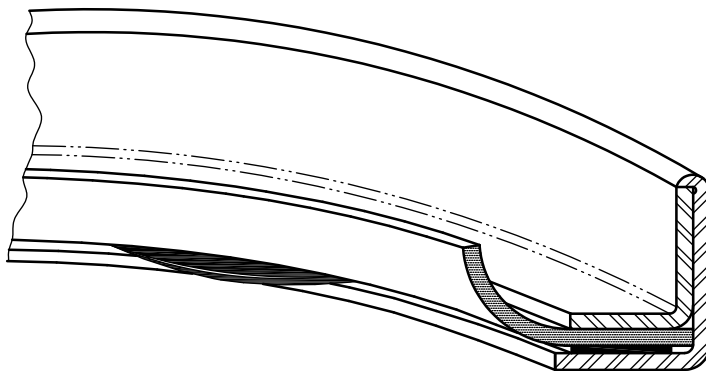

Figure 12 — Gasket extrusion

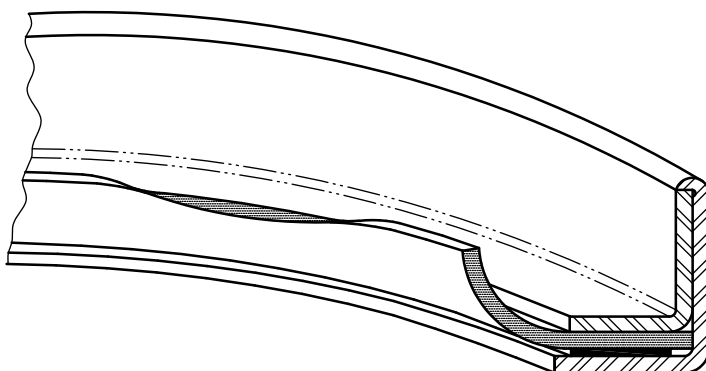

Figure 13 — Sealing lip inversion

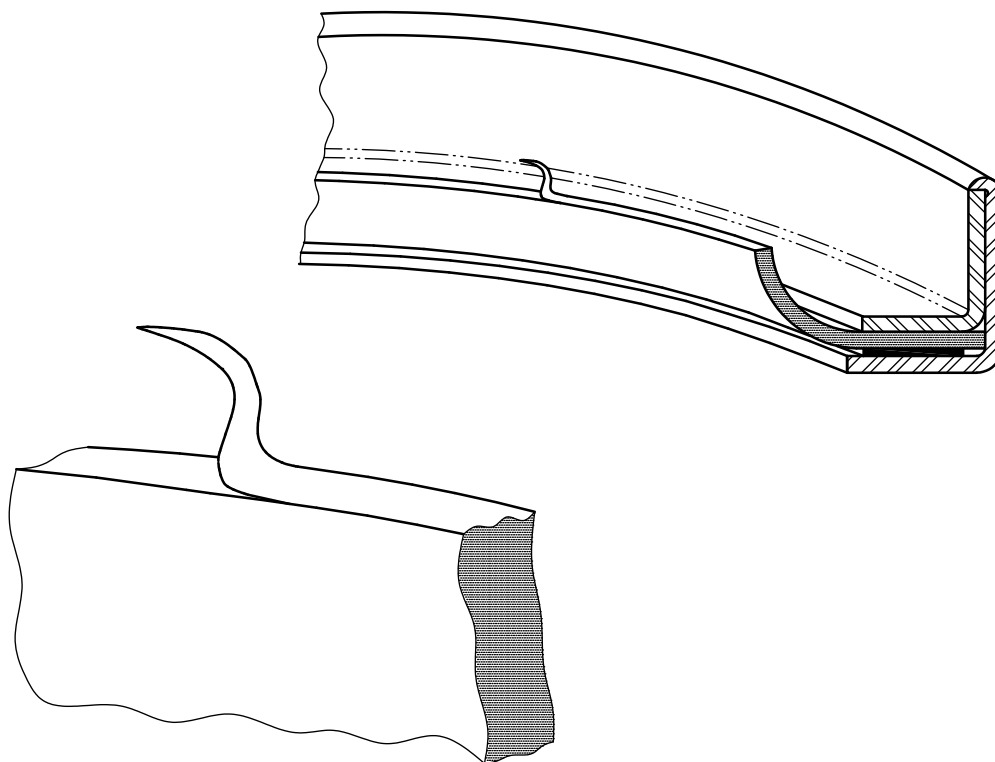
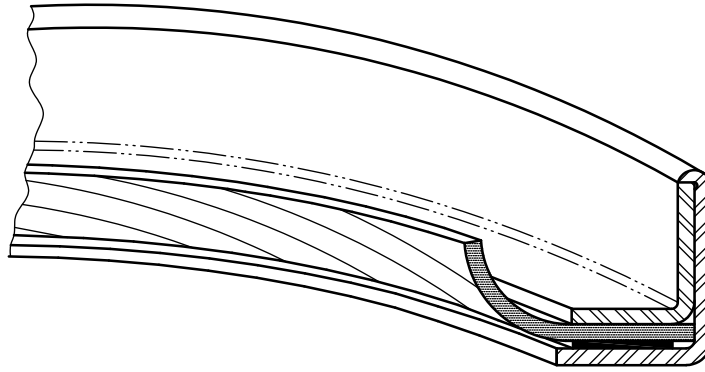
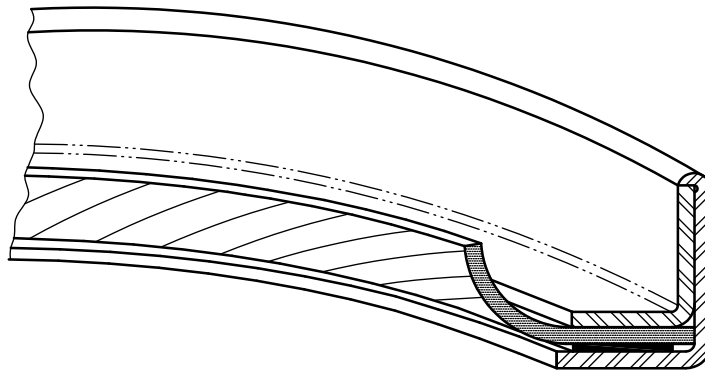

Figure 14 — Incomplete trim or folded flash



a) Correct: Hydrodynamic aid feature to suit clockwise rotating shaft when viewed from the air side



b) Incorrect

Figure 15 — Example of correct and incorrect spiral directions of the hydrodynamic aid

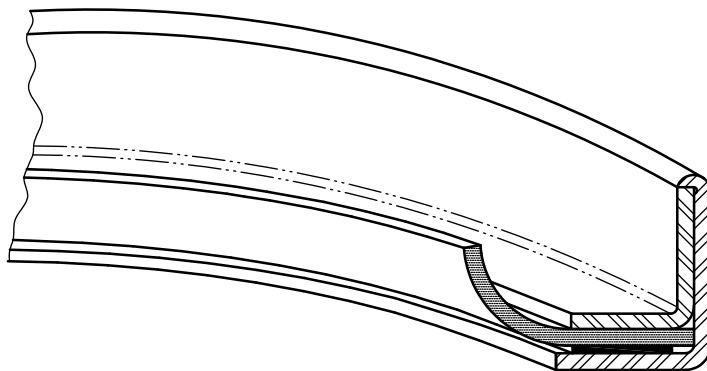

a) Acceptable

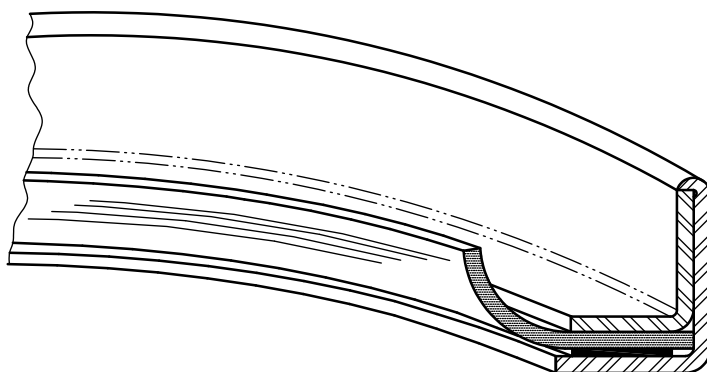

b) Unacceptable

The figure illustrates a rough surface finish of a plain lip element, e.g. machining grooves.

Figure 16 — Rough surface finish, sealing element

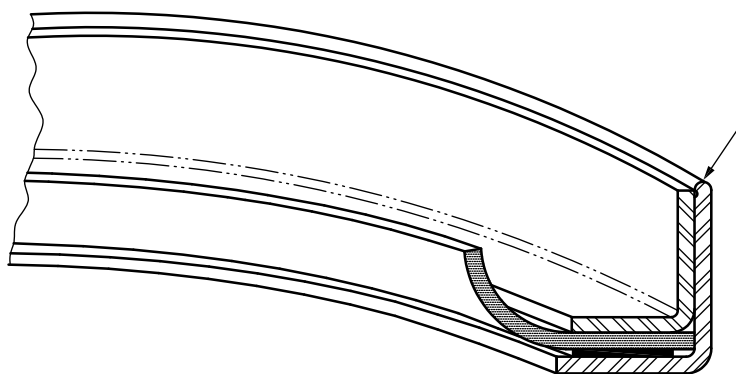

Figure 17 — Incorrect roll-over of retaining flange

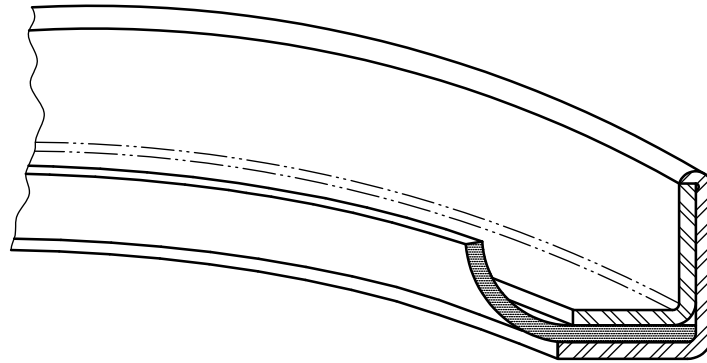
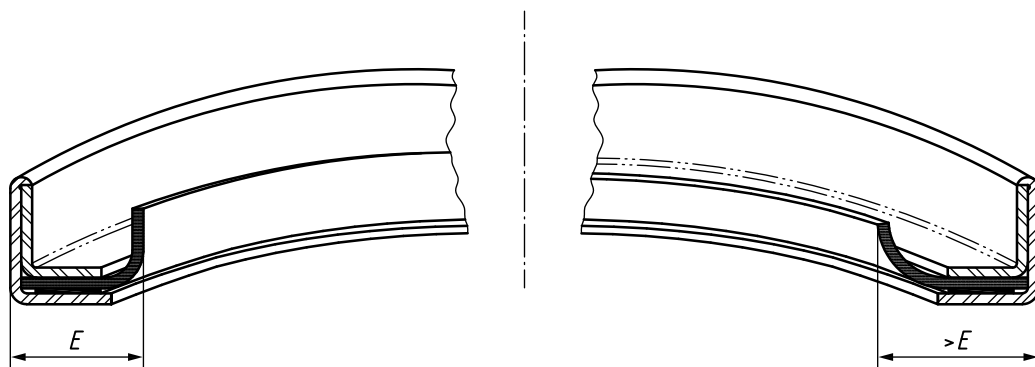
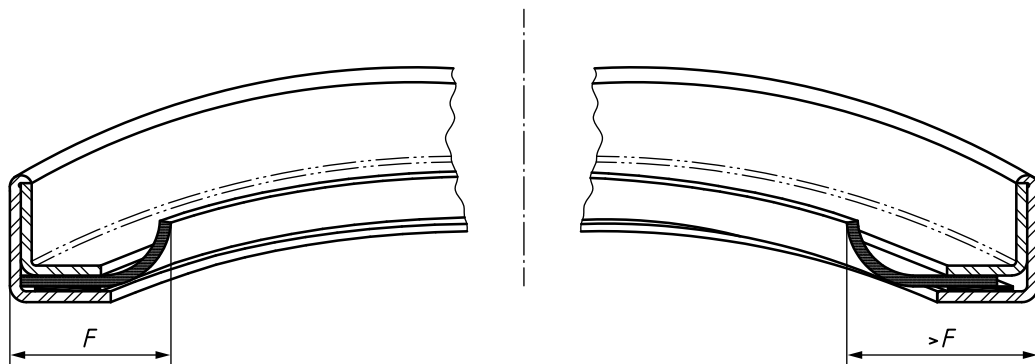

Figure 18 — Missing gasket



Sections are shown at 180° through a seal.

Figure 19 — Lip eccentric to outer case diameter (incorrectly formed on mandrel)



Sections are shown at 180° through a seal.

Figure 20 — Lip eccentric to outer case diameter (outer diameter of sealing element undersized)

Bibliography

- [1] ISO 6194-1, *Rotary shaft lip-type seals incorporating elastomeric sealing elements — Part 1: Nominal dimensions and tolerances*
- [2] ISO 6194-2, *Rotary shaft lip-type seals incorporating elastomeric sealing elements — Part 2: Vocabulary*
- [3] ISO 6194-3, *Rotary shaft lip-type seals incorporating elastomeric sealing elements — Part 3: Storage, handling and installation*
- [4] ISO 6194-4, *Rotary shaft lip-type seals incorporating elastomeric sealing elements — Part 4: Performance test procedures*
- [5] ISO 6194-5, *Rotary shaft lip-type seals incorporating elastomeric sealing elements — Part 5: Identification of visual imperfections*
- [6] ISO 16589-1, *Rotary shaft lip-type seals incorporating thermoplastic sealing elements — Part 1: Nominal dimensions and tolerances*

ICS 23.100.60; 83.140.50

Price based on 14 pages