

INTERNATIONAL STANDARD

ISO
16536

First edition
2012-05-15

Thermal insulating products for building applications — Determination of long- term water absorption by diffusion

*Produits isolants thermiques destinés aux applications du bâtiment —
Détermination de l'absorption d'eau à long terme par diffusion*



Reference number
ISO 16536:2012(E)

© ISO 2012

ISO 16536:2012(E)



COPYRIGHT PROTECTED DOCUMENT

© ISO 2012

All rights reserved. Unless otherwise specified, no part of this publication may be reproduced or utilized in any form or by any means, electronic or mechanical, including photocopying and microfilm, without permission in writing from either ISO at the address below or ISO's member body in the country of the requester.

ISO copyright office
Case postale 56 • CH-1211 Geneva 20
Tel. + 41 22 749 01 11
Fax + 41 22 749 09 47
E-mail copyright@iso.org
Web www.iso.org

Published in Switzerland

Contents		Page
Foreword		iv
Introduction		v
1 Scope		1
2 Normative references		1
3 Principle		1
4 Apparatus		1
5 Test specimens		2
5.1 Dimensions of test specimens		2
5.2 Number of test specimens		2
5.3 Preparation of test specimens		3
5.4 Conditioning of test specimens		3
6 Procedure		3
6.1 Test procedure		3
6.2 Test conditions		3
7 Calculation and expression of results		3
8 Accuracy of measurement		4
9 Test report		4

ISO 16536:2012(E)

Foreword

ISO (the International Organization for Standardization) is a worldwide federation of national standards bodies (ISO member bodies). The work of preparing International Standards is normally carried out through ISO technical committees. Each member body interested in a subject for which a technical committee has been established has the right to be represented on that committee. International organizations, governmental and non-governmental, in liaison with ISO, also take part in the work. ISO collaborates closely with the International Electrotechnical Commission (IEC) on all matters of electrotechnical standardization.

International Standards are drafted in accordance with the rules given in the ISO/IEC Directives, Part 2.

The main task of technical committees is to prepare International Standards. Draft International Standards adopted by the technical committees are circulated to the member bodies for voting. Publication as an International Standard requires approval by at least 75 % of the member bodies casting a vote.

Attention is drawn to the possibility that some of the elements of this document may be the subject of patent rights. ISO shall not be held responsible for identifying any or all such patent rights.

ISO 16536 was prepared by Technical Committee ISO/TC 163, *Thermal performance and energy use in the built environment*, Subcommittee SC 1, *Test and measurement methods*.

ISO 16536 includes the original EN 12088 prepared by Technical Committee CEN/TC 88 "Thermal insulating materials and products", with the following clauses modified to reflect the conditions for tropical countries:

Clause 5.4: Conditioning of test specimens;

Clause 6.2: Test conditions;

Clause 9: Test report.

Introduction

ISO 16536 is one of a series of existing European Standards on test methods which were adopted by ISO. This group of International Standards comprises the following group of interrelated standards:

ISO	Title	Respective EN standard
12344	Thermal insulating products for building applications — Determination of bending behaviour	EN 12089
12968	Thermal insulation products for building applications — Determination of the pull-off resistance of external thermal insulation composite systems (ETICS) (foam block test)	EN 13495
29465	Thermal insulating products for building applications — Determination of length and width	EN 822
29466	Thermal insulating products for building applications — Determination of thickness	EN 823
29467	Thermal insulating products for building applications — Determination of squareness	EN 824
29468	Thermal insulating products for building applications — Determination of flatness	EN 825
29469	Thermal insulating products for building applications — Determination of compression behaviour	EN 826
29470	Thermal insulating products for building applications — Determination of the apparent density	EN 1602
29471	Thermal insulating products for building applications — Determination of dimensional stability under constant normal laboratory conditions (23 degrees C/50 % relative humidity)	EN 1603
29472	Thermal insulating products for building applications — Determination of dimensional stability under specified temperature and humidity conditions	EN 1604
29764	Thermal insulating products for building applications — Determination of deformation under specified compressive load and temperature conditions	EN 1605
29765	Thermal insulating products for building applications — Determination of tensile strength perpendicular to faces	EN 1607
29766	Thermal insulating products for building applications — Determination of tensile strength parallel to faces	EN 1608
29767	Thermal insulating products for building applications — Determination of short-term water absorption by partial immersion	EN 1609
29768	Thermal insulating products for building applications — Determination of linear dimensions of test specimens	EN 12085
29769	Thermal insulating products for building applications — Determination of behaviour under point load	EN 12430
29770	Thermal insulating products for building applications — Determination of thickness for floating-floor insulating products	EN 12431

ISO 16536:2012(E)

29771	Thermal insulating materials for building applications — Determination of organic content	EN 13820
29803	Thermal insulation products for building applications — Determination of the resistance to impact of external thermal insulation composite systems (ETICS)	EN 13497
29804	Thermal insulation products for building applications — Determination of the tensile bond strength of the adhesive and of the base coat to the thermal insulation material	EN 13494
29805	Thermal insulation products for building applications — Determination of the mechanical properties of glass fibre meshes	EN 13496
16534	Thermal insulating products for building applications — Determination of compressive creep	EN 1606
16535	Thermal insulating products for building applications — Determination of long-term water absorption by immersion	EN 12087
16536	Thermal insulating products for building applications — Determination of long-term water absorption by diffusion	EN 12088
16537	Thermal insulating products for building applications — Determination of shear behaviour	EN 12090
16546	Thermal insulating products for building applications — Determination of freeze-thaw resistance	EN 12091
16544	Thermal insulating products for building applications — Conditioning to moisture equilibrium under specified temperature and humidity conditions	EN 12429
16545	Thermal insulating products for building applications — Determination of behaviour under cyclic loading	EN 13793

A further group of existing European Standards on test methods for products used to insulate building equipment and industrial installations comprises the following group of interrelated International Standards:

ISO 12623	Thermal insulating products for building equipment and industrial installations — Determination of short-term water absorption by partial immersion of preformed pipe insulation	EN 13472
ISO 12624	Thermal insulating products for building equipment and industrial installations — Determination of trace quantities of water soluble chloride, fluoride, silicate, sodium ions and pH	EN 13468
ISO 12628	Thermal insulating products for building equipment and industrial installations — Determination of dimensions, squareness and linearity of preformed pipe insulation	EN 13467
ISO 12629	Thermal insulating products for building equipment and industrial installations — Determination of water vapour transmission properties of preformed pipe insulation	EN 13469

Thermal insulating products for building applications — Determination of long-term water absorption by diffusion

1 Scope

This International Standard specifies the equipment and procedures for determining the long-term water absorption of test specimens by diffusion. It is applicable to thermal insulating products.

The test is intended to simulate the water absorption of products subjected to high relative humidities, approximating to 100 %, on both sides and subjected to a water vapour pressure gradient for a long period of time, e.g. inverted roof or unprotected ground insulation.

The test is not applicable for all types of thermal insulating products. The product standard should state for which of its products, if any, this test is applicable.

NOTE For unprotected ground insulation, the temperature of 50 °C may be replaced by a lower temperature, when more data are available.

2 Normative references

The following referenced documents are indispensable for the application of this document. For dated references, only the edition cited applies. For undated references, the latest edition of the referenced document (including any amendments) applies.

ISO 29768, *Thermal insulating products for building applications — Determination of linear dimensions of test specimens*

3 Principle

The long-term water absorption by diffusion is determined by measuring the increase in the mass of a test specimen subjected to a water vapour pressure difference and temperature gradient for a period of 28 days.

4 Apparatus

- 4.1 **Balance**, allows the determination of the mass of a test specimen to 0,1 g.
- 4.2 **Corrosion-resistant container**, a frame supporting the test specimens.
- 4.3 **Heating device**, a thermostat which provides water temperature control to (50 ± 1) °C.
- 4.4 **Cooling plate**, thermally insulated on the outside, operating at a temperature of $(1 \pm 0,5)$ °C.
- 4.5 **Tap water**, adjusted to a temperature of (50 ± 1) °C.

The principle of the apparatus assembly is illustrated in Figure 1.

ISO 16536:2012(E)

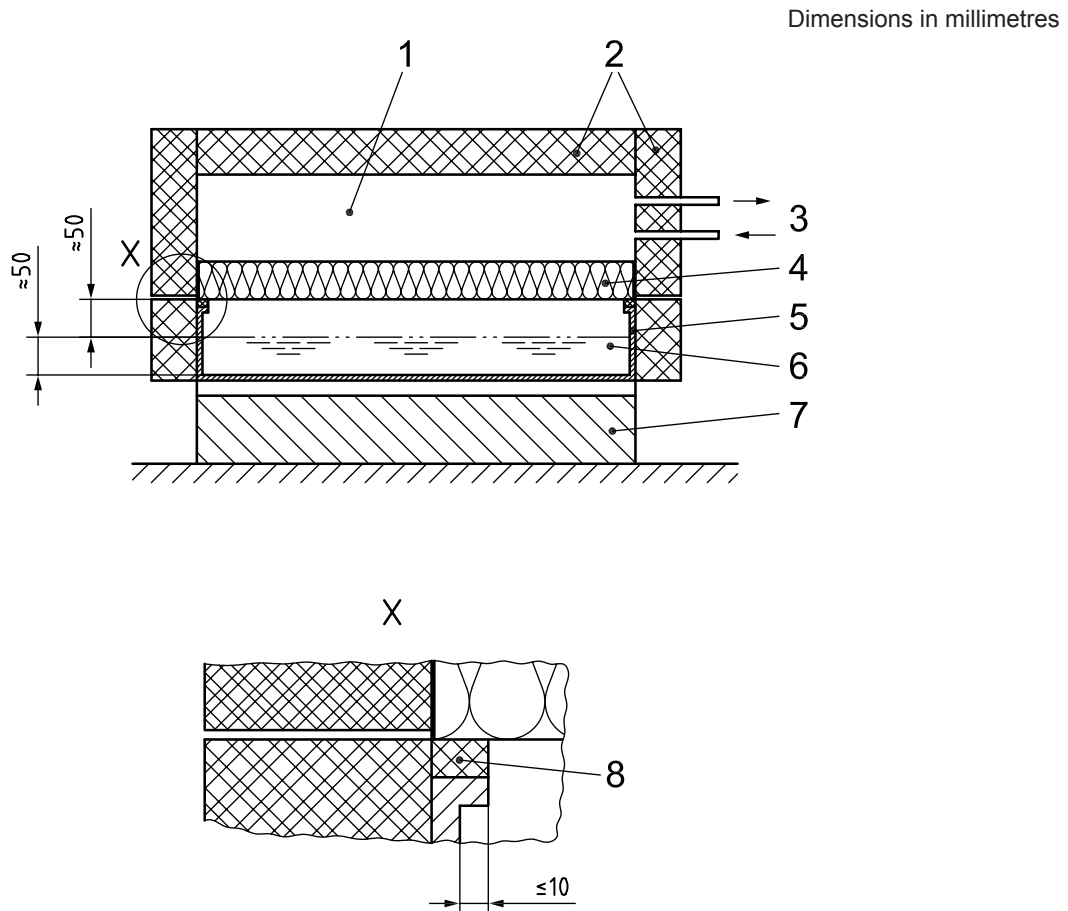

Key

- 1 cooling plate
- 2 thermal insulation of the cooling plate and the container
- 3 cooling medium inlet and outlet
- 4 test specimen
- 5 corrosion-resistant container with a frame supporting the test specimen
- 6 tap water
- 7 heating device with a thermostat
- 8 sealing

Figure 1 — Example of test device for water absorption by diffusion

5 Test specimens

5.1 Dimensions of test specimens

The thickness of the test specimens shall be the original product thickness.

The test specimens shall be squares with squarely cut edges having sides of (500 ± 1) mm. If the product is not large enough to permit this size of test specimen, the test specimen size shall be reduced accordingly. Test specimens shall contain no joints.

5.2 Number of test specimens

The number of test specimens shall be at least two.

5.3 Preparation of test specimens

The test specimens shall be cut so that they do not include original product edges.

Test specimens shall be prepared by methods that do not substantially change the original structure of the product. Any facings, skins and/or coatings shall be retained.

NOTE Special methods of preparation, when needed, are given in the relevant product standard or any other technical specification.

5.4 Conditioning of test specimens

The test specimens shall be stored for at least 6 h at (23 ± 5) °C. In case of dispute they shall be stored at (23 ± 2) °C and (50 ± 5) % relative humidity (RH) for the time stated in the relevant product standard with a minimum of 6 h.

In tropical countries, different conditioning and testing conditions can be relevant. In this case, the conditions shall be (27 ± 5) °C and (65 ± 5) % RH, and be stated clearly in the test report.

6 Procedure

6.1 Test procedure

The dimensions of the test specimens shall be measured in accordance with ISO 29768.

Weigh the test specimen to the nearest 0,1 g to determine its initial mass, m_0 .

Place the test specimen on the frame of the container. If the product is faced on one side, begin the test with it facing upwards. Seal the bottom edge of the test specimen to the container. The width of the sealing shall be ≤ 10 mm (see Figure 1). Place the insulated cooling plate on top of the test specimen.

Subject the test specimen to a temperature and a water vapour pressure difference for 28 days by maintaining the water at a temperature of (50 ± 1) °C and the cooling on the other side at a temperature of $(1 \pm 0,5)$ °C.

Turn the test specimen over every 7 days.

After 28 days, remove the test specimen and wipe off any surface water. Weigh the test specimen again to determine its mass, m_D .

6.2 Test conditions

The test shall be carried out at (23 ± 2) °C and (50 ± 5) % RH.

NOTE Other conditions may be given in the relevant product standard or can be agreed between parties.

In tropical countries, different conditioning and testing conditions can be relevant. In this case, the conditions shall be (27 ± 2) °C and (65 ± 5) % RH.

7 Calculation and expression of results

The test result, W_{dp} or W_{dv} , shall be the mean value of the individual values.

Results shall not be extrapolated to other thicknesses.

Calculate the long-term water absorption by diffusion for each test specimen, W_{dp} or W_{dv} , in kilogrammes per square metre or volume percent using Equation (1) or (2):

$$W_{dp} = \frac{m_D - m_0}{A_p} \quad (1)$$

ISO 16536:2012(E)

$$W_{dV} = \frac{m_D - m_0}{A_p \times d} \times \frac{100}{\rho_W} \quad (2)$$

where

m_0 is the initial mass of the test specimen, in kg;

m_D is the mass of the test specimen after submission to water absorption by diffusion for 28 days, in kg;

A_p is the bottom surface area of the test specimen, in m²;

d is the thickness of the test specimen, in m;

ρ_W is the density of water, assumed to be 1000 kg/m³.

W_{dp} shall be rounded to the nearest 0,01 kg/m².

W_{dV} shall be rounded to the nearest 0,1 volume percent.

8 Accuracy of measurement

NOTE It has not been possible to include a statement on the accuracy of measurement in this edition of this International Standard, but it is intended to include such a statement when this International Standard is next revised.

9 Test report

The test report shall include the following information:

- a) reference to this International Standard, i.e. ISO 16536:2012;
- b) product identification
 - 1) product name, factory, manufacturer or supplier;
 - 2) production code number;
 - 3) type of product;
 - 4) packaging;
 - 5) the form in which the product arrived at the laboratory;
 - 6) other information as appropriate, e.g. nominal thickness, nominal density;
- c) test procedure
 - 1) pre-test history and sampling, e.g. who sampled and where;
 - 2) conditioning;
 - 3) if any deviation from Clauses 6 and 7;
 - 4) date of testing;
 - 5) conditioning in tropical countries, if applicable;
 - 6) general information relating to the test;
 - 7) events which may have affected the results;
- d) results (all individual values and the mean value).

Information about the apparatus and identity of the technician should be available in the laboratory but it need not be recorded in the report.

ISO 16536:2012(E)

ICS 91.100.60

Price based on 5 pages