

INTERNATIONAL
STANDARD

ISO
16508
CIE S 006.1/E

First edition
1999-12-15

Corrected and reprinted
2000-11-15

**Road traffic lights — Photometric
properties of 200 mm roundel signals**

*Feux de circulation — Caractéristiques photométriques des feux de
signalisation avec un diamètre de 200 mm*



Reference number
ISO 16508:1999(E)
CIE S 006.1/E-1998

© ISO 1999

PDF disclaimer

This PDF file may contain embedded typefaces. In accordance with Adobe's licensing policy, this file may be printed or viewed but shall not be edited unless the typefaces which are embedded are licensed to and installed on the computer performing the editing. In downloading this file, parties accept therein the responsibility of not infringing Adobe's licensing policy. The ISO Central Secretariat accepts no liability in this area.

Adobe is a trademark of Adobe Systems Incorporated.

Details of the software products used to create this PDF file can be found in the General Info relative to the file; the PDF-creation parameters were optimized for printing. Every care has been taken to ensure that the file is suitable for use by ISO member bodies. In the unlikely event that a problem relating to it is found, please inform the Central Secretariat at the address given below.

© ISO 1999

All rights reserved. Unless otherwise specified, no part of this publication may be reproduced or utilized in any form or by any means, electronic or mechanical, including photocopying and microfilm, without permission in writing from either ISO at the address below or ISO's member body in the country of the requester.

ISO copyright office
Case postale 56 • CH-1211 Geneva 20
Tel. + 41 22 749 01 11
Fax + 41 22 749 09 47
E-mail copyright@iso.ch
Web www.iso.ch

Printed in Switzerland

Foreword

ISO (the International Organization for Standardization) is a worldwide federation of national standards bodies (ISO member bodies). The work of preparing International Standards is normally carried out through ISO technical committees. Each member body interested in a subject for which a technical committee has been established has the right to be represented on that committee. International organizations, governmental and non-governmental, in liaison with ISO, also take part in the work. ISO collaborates closely with the International Electrotechnical Commission (IEC) on all matters of electrotechnical standardization.

International Standard ISO 16508 was prepared as Standard CIE S 006.1/E by the International Commission on Illumination, which has been recognized by the ISO Council as an international standardizing body. It was adopted by ISO under a special procedure which requires approval by at least 75 % of the member bodies casting a vote, and is published as a joint ISO/CIE edition.

The International Commission on Illumination (abbreviated as CIE from its French title) is an organization devoted to international cooperation and exchange of information among its member countries on all matters relating to the science and art of lighting.

International Standard ISO 16508 was prepared by Technical Committee 4-29 (Standard on Road Traffic Lights) of the CIE.

This first edition replaces the recommendations made on 200 mm roundel signals in CIE 79-1988.

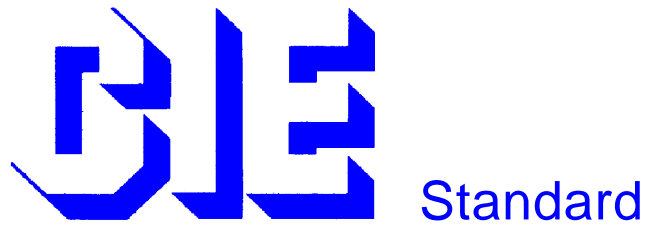

ISO 16508:1999(E)
CIE S 006.1/E-1998

Road Traffic Lights — Photometric Properties of 200 mm Roundel Signals

Feux de circulation — Caractéristiques photométriques des feux de signalisation avec un diamètre de 200 mm

Straßenverkehrslichtzeichen — Photometrische Eigenschaften von runden Signalleuchten mit 200 mm Durchmesser

CIE Standards are copyrighted and shall not be reproduced in any form, entirely or partly, without the explicit agreement of the CIE.

CIE Central Bureau, Vienna
Kegelgasse 27, A-1030 Vienna, Austria

S 006.1/E-1998

UDC: 628.975
656.054

Descriptor: Signal lighting
Traffic signals

Road Traffic Lights – Photometric Properties of 200 mm Roundel Signals

CONTENTS

	page
Foreword	1
1. Scope	1
2. Normative References	1
3. Definitions	2
4. Requirements	2
4.1 Luminous Intensity - Minimum Operating Values for 200 mm Roundel Traffic Lights	2
4.1.1 Luminous Intensity Distribution of Lights	2
4.1.2 Uniformity of Luminance	3
4.2 Sun Phantom	3
4.3 Background Screen	4
4.4 Colour of Light Signals	4
5. Test Methods	4
6. Appendix A: Test Method for Determining Phantom Light Luminance Ratio (non-normative)	4

Foreword

National and international standards for road traffic signal lights usually specify requirements for the luminous intensity of the lights to ensure that the signals will be visible in adequate time for an approaching driver to safely and efficiently respond to the signal on roads where speeds are low.

The official guidance of the Commission Internationale de l'Eclairage (CIE) for traffic signal luminous intensity (CIE 79-1988: *A Guide for the Design of Road Traffic Lights*) has been widely followed as providing sound direction for standard development. This guidance was based on a comprehensive review of the subject published as a CIE Technical Report (CIE 48-1980: *Light Signals for Road Traffic Control*).

The CIE undertook a major review of its recommendations in the period 1989 to 1994 (see CIE 107-1994: *Review of the official recommendations of the CIE for the colours of signal lights* and CIE DS004.2-1996: *Colours of light signals*) and this Standard is based on that review. Technical Committee 4-29 (*Standard on Road Traffic Lights*) of Division 4 of the CIE (*Lighting and Signalling for Transport*) was responsible for the review and the drafting of this Standard. It should be noted that this Standard considers only a few of the topics covered in CIE 79-1988. These are the topics for which supporting research and practical experience were strong enough to support standardisation. For topics not covered in this Standard, such as guidance concerning higher speed roadways and traffic lights using symbols, the user is advised to follow the guidance provided in CIE 79-1988.

This Standard has been approved by the CIE and replaces the recommendations made on 200 mm roundel signals in CIE Publication 79-1988.

1. Scope

The visibility of a road traffic signal depends on many factors, the most important of which are the colour, luminous intensity and luminous intensity distribution of the light.

This Standard deals with the colour, luminous intensity and luminous intensity distribution for 200 mm road traffic signals. The serious problem of sun phantom, which can affect the correct recognition of the light, is included in the Standard.

Reference documents relating to the colour of road traffic signals are detailed.

2. Normative References

The following standards contain provisions which, through reference in this text, constitute provisions of this International Standard. At the time of publication, the editions indicated were valid. All standards are subject to revision, and parties to agreements based on this International Standard are encouraged to investigate the possibility of applying the most recent edition of the standards indicated below. Members of IEC and ISO maintain registers of currently valid International Standards.

- CIE 17.4-1987: *International Lighting Vocabulary*
CIE 18.2-1983: *The basis of physical photometry*
CIE 38-1977: *Radiometric and photometric characteristics of materials and their measurement*
CIE 48-1980: *Light signals for road traffic control*
CIE 79-1988: *A guide for the design of road traffic lights*
CIE 107-1994: *Review of the official recommendations of the CIE for the colours of signal lights*
CIE DS004.4-1998: *Colours of light signals*

3. Definitions

Definitions of all photometric terms used in this Standard are described in the CIE International Lighting Vocabulary, Publication CIE 17.4. For the purposes of this International Standard, the following definitions apply.

- Geometric axis: The perpendicular passing through the geometric centre of the front surface of the signal lens and perpendicular to the tangent to this point.
- Optical axis: The axis of maximum measured intensity.
- Reference axis: Either the geometric or the optical axis, as defined by the manufacturer or supplier of an optical system, to be used by the testing authority to assess the optical performance of an optical assembly for compliance with this Standard.

4. Requirements

4.1 Luminous Intensity - Minimum Operating Values for 200 mm Roundel Traffic Lights

By day, all roundel lights shall have a minimum operational luminous intensity of 200 cd along the reference axis for the light. Increased values for specific colours may be required by individual countries to meet traffic situations. Examples of situations which might require higher luminous intensities for some or all of the roundels of a traffic signal are as follows. For high speed roads, and at locations where greater conspicuity is needed, larger diameter signal faces with higher luminous intensity should be provided for in National Codes. A situation which may require use of different luminous intensities between colours occurs during hours of darkness when drivers with poor colour vision can not easily determine from the safe stopping sight distance which signal roundel is illuminated. Typically, this occurs on unlighted, high speed roadways where the signal is seen against a dark surround.

Normally, traffic signals should have the same luminous intensity during both day and night conditions. However, in some situations, the luminous intensity used during the day will produce a glaring situation at night, especially in dark surroundings. The luminous intensity may be reduced in these situations at night by dimming. If dimming is employed, the RED roundel shall have a luminous intensity along the reference axis of not less than 50 cd and not more than 200 cd, but a more restrictive upper limit of 100 cd is advised. The same luminous intensity ratio as used in daytime between the RED signal and other colour signals shall be maintained. On high speed roads, in urban areas with bright surroundings, and in other places where the reduced nighttime intensities are not considered desirable, the normal daytime intensity shall be used.

4.1.1 Luminous Intensity Distribution of Lights

The required distribution of luminous intensity for a traffic light shall be as follows:

- a) the intensity within 10° to the right and left of the reference axis and within 5° below the reference axis shall be at least 50% of the measured intensity on the reference axis.
- b) The intensity in any direction within 20° to the right and left of the reference axis and within 10° below the reference axis shall be at least 12,5% of the measured intensity on the reference axis.
- c) Additional distribution requirements may be provided for in National Codes to accommodate the prevailing road geometry.

4.1.2 Uniformity of Luminance

The roundel of a traffic light shall appear reasonably uniformly bright over its entire surface, and shall have no abrupt changes of luminance. The ratio of the greatest and least luminance on a roundel shall not exceed 10 to 1 but it is recommended that this ratio should not exceed 5 to 1. If a traffic light is constructed using discrete luminous areas, for example by means of luminous optical fibres or LED assemblies, then the luminance ratios of adjacent luminous areas shall not exceed 5 to 1.

The luminance shall be measured with a luminance meter, set axially to the roundel of the traffic signal light. The distance between the luminance meter and the traffic signal light shall be set so that with the selected acceptance angle of the luminance meter a 25 mm round area of the signal light surface should be averaged. At least 13 measurements shall be made: in the middle of the signal light, in four perpendicular directions at 40 mm and 80 mm from the middle point, and at 56,6 mm from the middle point at four locations that are at 45° to the previous directions (see Figure 1 for details). In case the roundel contains a symbol, the measurement shall be performed at five different, nonoverlapping regions of the symbol with an acceptance angle of the luminance meter that permits measurement within 80 per cent of the symbol width or the 25 mm area, whichever is smaller.

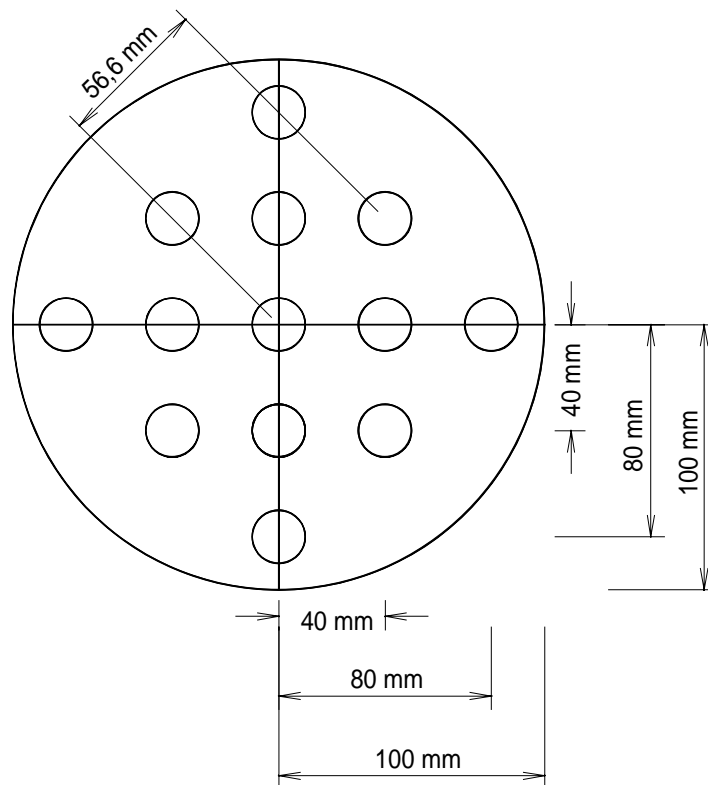

Figure 1 - Location of luminance measurement on roundel signal lights to determine uniformity of luminance.

All the values are applicable to the three recommended colours for road signals: red, yellow, and green.

4.2 Sun Phantom

Sun phantom is a false light signal caused by reflection of radiation from the sun by the optical surfaces of the signal assembly. It makes a light appear to be switched on when in fact it is off, and it may produce confusion for the road user unless the luminous intensity of the real light signal is considerably greater than that of any false signal. The minimum ratio of the intensity of the real to false signals shall be at least 15 to 1 for roundel lights when direct sunlight of

ISO 16508:1999(E)

CIE S 006.1/E-1998

10 000 lux is incident on the surface of the roundel from an angle of 10° vertically above the reference axis and when tested without a visor.

Each individual traffic light should be fitted with a visor in order to reduce the influence of the direct sunlight and ambient light (including public lighting) on the traffic signals.

For avoiding sun-phantom effects and determining their magnitude see Appendix A and CIE 48-1980.

4.3 Background Screen

Background screens should be used as a standard fitting on all vehicular traffic lights, and particularly on lights supported over the road, except when local conditions may make their use impractical or unnecessary.

A screen should have an overall width of about three times the diameter of the roundel associated with it. It is further recommended that the front of the screen be matt black, or matt dark grey, with a light-coloured, preferably white, rim. The luminance factor of the dark grey should be less than 0,16.

4.4 Colour of Light Signals

The specification of the colours of road traffic lights shall be in accordance with publication CIE DS 004.4-1998: *Colours of Light Signals* for Class A1 Red, Yellow and Class A Green. More detailed information concerning the equations and boundaries of the recommended chromaticity regions can be obtained from this CIE publication.

5. Test Methods

CIE Publications 18.2 and 38 detail the several methods of measurement that have been approved by the CIE.

6. Appendix A: Test Method for Determining Phantom Light Luminance Ratio

(Non-normative)

For testing the phantom light luminance ratio, the roundel light shall be fitted with its signal light source that will be used also in practice, and powered by the nominal voltage (and frequency) for which the system was built and will be used. The roundel shall be mounted in its normal working position with the reference axis set horizontally, see Figure A.1, items (1) and (2): (1) is the roundel signal, (2) is the front surface (window or lens) of the signal light. The test shall be performed in a dark room or at night. Care should be taken to avoid stray light.

The front surface of the roundel shall be illuminated by a projector simulating direct sunlight. The distance between the projector (3) and the front surface of the roundel (2) shall be more than 10 m. The projector shall produce an illumination on the front surface of the roundel of 10 000 lux at the colour temperature of CIE standard illuminant A (2856 K).

The reference axis of the roundel (lying in the horizontal plane) and the optical axis of the projector shall form an angle of $\gamma = 10^\circ$; the plane produced by the reference axis of the roundel and the optical axis of the projector shall be vertical, the projector being above the horizontal plane in which the reference axis of the roundel is located. The opening angle of the projector emitting surface seen from the front surface of the roundel (angle α) shall be smaller than 1°, similarly the opening angle of the photometer seen from the front surface of the roundel (angle β) shall be smaller than 1°. The distance between the front surface and the photometer (4) lying on the reference axis of the roundel shall be 10 m.

The photometer shall be a luminance meter with a $V(\lambda)$ corrected photodetector, the spectral mismatch error (f_1') of which shall be < 3 %. The aperture angle of the luminance meter shall be between 0,1° and 0,5°.

Figure A.1 shows the schematic arrangement of the test set-up.

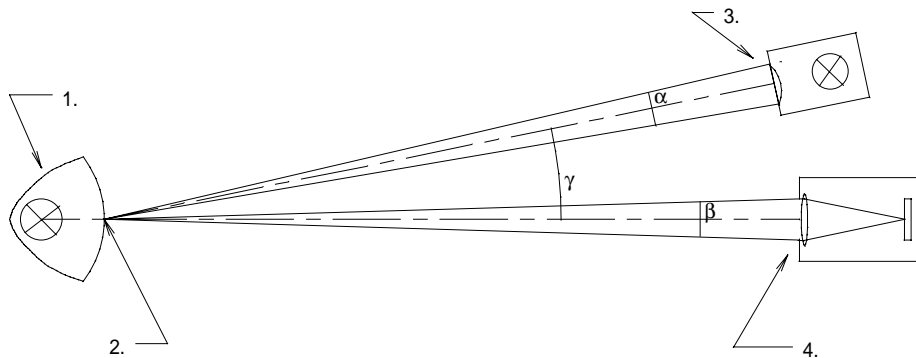

Figure A.1 - Schematic test set-up for determining phantom signal ratio.

The phantom light luminance ratio is measured by

- Measuring the luminance of the roundel when the roundel light source is switched on, and the projector is switched off: L_{signal} .
- Measuring the luminance of the front surface of the roundel when the roundel light source is switched off and the projector is switched on: $L_{\text{phant},10\text{klx}}$. The projector should produce an illumination (E_t) in the plane of the roundel front surface of 10 000 lux.
- If the effective illuminance ($E_{t,\text{eff}}$) in the plane of the front surface of the roundel is not 10 000 lx, then $L_{\text{phant},10\text{klx}}$ can be calculated from the measured $L_{\text{phant},\text{eff}}$ as:

$$L_{\text{phant},10\text{klx}} = L_{\text{phant},\text{eff}} \frac{10\,000}{E_{t,\text{eff}}}$$

- The phantom light luminance ratio: $L_{\text{signal}} / L_{\text{phant},10\text{klx}} > 15$ is required.

CIE Central Bureau
Kegelgasse 27
A-1030 Vienna
Austria
Tel.: +43 1 714 3187 0
Fax: +43 1 713 0838 18
e-mail: ciecb@ping.at
WWW: <http://www.cie.co.at/cie/home.html>

