

INTERNATIONAL STANDARD

ISO 16486-5

First edition
2012-06-01

Plastics piping systems for the supply of gaseous fuels — Unplasticized polyamide (PA-U) piping systems with fusion jointing and mechanical jointing —

Part 5: Fitness for purpose of the system

*Systèmes de canalisations en matières plastiques pour la
distribution de combustibles gazeux — Systèmes de canalisations
en polyamide non plastifié (PA-U) avec assemblages par soudage et
assemblages mécaniques —*

Partie 5: Aptitude à l'emploi du système



Reference number
ISO 16486-5:2012(E)

© ISO 2012

ISO 16486-5:2012(E)



COPYRIGHT PROTECTED DOCUMENT

© ISO 2012

All rights reserved. Unless otherwise specified, no part of this publication may be reproduced or utilized in any form or by any means, electronic or mechanical, including photocopying and microfilm, without permission in writing from either ISO at the address below or ISO's member body in the country of the requester.

ISO copyright office
Case postale 56 • CH-1211 Geneva 20
Tel. + 41 22 749 01 11
Fax + 41 22 749 09 47
E-mail copyright@iso.org
Web www.iso.org

Published in Switzerland

Contents	Page
Foreword	iv
Introduction	v
1 Scope	1
2 Normative references	1
3 Terms, definitions, symbols and abbreviated terms	2
3.1 Terms and definitions — General	2
3.2 Terms and definitions for preparation of test assemblies by electrofusion	2
4 Fitness for purpose	5
4.1 Method of preparation of assemblies for testing	5
4.2 Requirements for fitness for purpose	5
Annex A (normative) Preparation of test assemblies by butt fusion	10
Annex B (normative) Preparation of test assemblies by electrofusion	13
Annex C (normative) Test methods for the assessment of fitness for purpose of transition fittings	18
Bibliography	20

ISO 16486-5:2012(E)

Foreword

ISO (the International Organization for Standardization) is a worldwide federation of national standards bodies (ISO member bodies). The work of preparing International Standards is normally carried out through ISO technical committees. Each member body interested in a subject for which a technical committee has been established has the right to be represented on that committee. International organizations, governmental and non-governmental, in liaison with ISO, also take part in the work. ISO collaborates closely with the International Electrotechnical Commission (IEC) on all matters of electrotechnical standardization.

International Standards are drafted in accordance with the rules given in the ISO/IEC Directives, Part 2.

The main task of technical committees is to prepare International Standards. Draft International Standards adopted by the technical committees are circulated to the member bodies for voting. Publication as an International Standard requires approval by at least 75 % of the member bodies casting a vote.

Attention is drawn to the possibility that some of the elements of this document may be the subject of patent rights. ISO shall not be held responsible for identifying any or all such patent rights.

ISO 16486-5 was prepared by Technical Committee ISO/TC 138, *Plastics pipes, fittings and valves for the transport of fluids*, Subcommittee SC 4, *Plastics pipes and fittings for the supply of gaseous fuels*.

This first edition of ISO 16486-5 cancels and replaces the first edition of ISO 22621-5:2010 which has been technically revised.

ISO 16486 consists of the following parts, under the general title *Plastics piping systems for the supply of gaseous fuels — Unplasticized polyamide (PA-U) piping systems with fusion jointing and mechanical jointing*:

ISO 16486 consists of the following parts, under the general title *Plastics piping systems for the supply of gaseous fuels — Unplasticized polyamide (PA-U) piping systems with fusion jointing and mechanical jointing*:

- *Part 1: General*
- *Part 2: Pipes*
- *Part 3: Fittings*
- *Part 5: Fitness for purpose of the system*
- *Part 6: Code of practice for design, handling and installation*

Introduction

Thin wall thickness unplasticized polyamide (PA-U) pipes and solvent cement joints are used typically for low pressures, while thicker wall thickness pipes and butt fusion, electrofusion or mechanical joints are typically used for high pressures.

For technical and safety reasons, it is not possible to mix the components of the two types of piping system (thin wall thickness pipes cannot be jointed by butt fusion or mechanical joints and vice versa). In particular, solvent cement joints must not be used for jointing for high pressure piping systems.

So for the time being, the standardization programme dealing with unplasticized polyamide (PA-U) piping systems for the supply of gaseous fuels is split into two series of International Standards, with one series (ISO 17467) covering piping systems the components of which are connected by solvent cement jointing and the other (ISO 16486) the components of which are connected by fusion jointing and/or mechanical jointing. When more experience will be gained from the field, it might be reasonable to merge the ISO 17467 series and the ISO 16486 series in one single series applicable to PA-U piping systems.

A similar series (ISO 17135) for fusion and mechanically jointed plasticized polyamide (PA-P) piping systems is in preparation.

Plastics piping systems for the supply of gaseous fuels — Unplasticized polyamide (PA-U) piping systems with fusion jointing and mechanical jointing —

Part 5: Fitness for purpose of the system

1 Scope

This part of ISO 16486 specifies the requirements of fitness for purpose of the unplasticized polyamide (PA-U) piping system, intended to be buried and used for the supply of gaseous fuels. It also specifies the definitions of electrofusion and butt fusion joints.

This part of ISO 16486 specifies the method of preparation of test piece joints and the tests to be carried out on these joints for assessing the fitness for purpose of the system under normal and extreme conditions. It also specifies the test parameters for the test methods to which it refers.

ISO 16486 is applicable to PA-U piping systems the components of which are connected by fusion jointing and/or mechanical jointing.

In conjunction with the other parts of ISO 16486, it is applicable to PA-U fittings, their joints and to joints with components of PA-U.

2 Normative references

The following documents, in whole or in part, are normatively referenced in this document and are indispensable for its application. For dated references, only the edition cited applies. For undated references, the latest edition of the referenced document (including any amendments) applies.

ISO 291, *Plastics — Standard atmospheres for conditioning and testing*

ISO 1167-1, *Thermoplastics pipes, fittings and assemblies for the conveyance of fluids — Determination of the resistance to internal pressure — Part 1: General method*

ISO 1167-4, *Thermoplastics pipes, fittings and assemblies for the conveyance of fluids — Determination of the resistance to internal pressure — Part 4: Preparation of assemblies*

ISO 6259-1, *Thermoplastics pipes — Determination of tensile properties — Part 1: General test method*

ISO 13953, *Polyethylene (PE) pipes and fittings — Determination of the tensile strength and failure mode of test pieces from a butt-fused joint*

ISO 13954, *Plastics pipes and fittings — Peel decohesion test for polyethylene (PE) electrofusion assemblies of nominal outside diameter greater than or equal to 90 mm*

ISO 13955, *Plastics pipes and fittings — Crushing decohesion test for polyethylene (PE) electrofusion assemblies*

ISO 13956:2010, *Plastics pipes and fittings — Decohesion test of polyethylene (PE) saddle fusion joints — Evaluation of ductility of fusion joint interface by tear test*

ISO 16486-1, *Plastics piping systems for the supply of gaseous fuels — Unplasticized polyamide (PA-U) piping systems with fusion jointing and mechanical jointing — Part 1: General*

ISO 16486-2, *Plastics piping systems for the supply of gaseous fuels — Unplasticized polyamide (PA-U) piping systems with fusion jointing and mechanical jointing — Part 2: Pipes*

ISO 16486-5:2012(E)

ISO 16486-3, *Plastics piping systems for the supply of gaseous fuels — Unplasticized polyamide (PA-U) piping systems with fusion jointing and mechanical jointing — Part 3: Fittings*

3 Terms, definitions, symbols and abbreviated terms

For the purposes of this document, the terms, definitions, symbols and abbreviated terms given in ISO 16486-1 and the following apply.

3.1 Terms and definitions — General

3.1.1

electrofusion joint

joint between a PA-U electrofusion socket or saddle fitting and a pipe or a spigot end fitting

NOTE The electrofusion fittings are heated by the Joule effect of the heating element incorporated at their jointing surfaces, causing the material adjacent to them to melt and the pipe and fitting surfaces to fuse.

3.1.2

butt fusion joint (using heated tool)

joint made by heating the planed ends the surfaces of which match by holding them against a flat heating plate until the PA-U material reaches fusion temperature, removing the heating plate quickly and pushing the two softened ends against one another

3.1.3

fusion compatibility

ability of two unplasticized polyamide materials of the same type to be fused together to form a joint which conforms to the performance requirements of this part of ISO 16486

3.1.4

transition fitting

fitting that makes a transition joint between a unplasticized polyamide (PA-U) piping and a metallic pipe

3.1.5

transition joint

joint at which two different piping materials (the PA-U and metal piping) are connected

3.1.6

anodeless riser

type of transition fitting which is designed to transport gas from an underground unplasticized polyamide (PA-U) service line to above-ground steel piping

NOTE In an anodeless riser, the PA-U pipe is always the gas carrier, at least, in the below ground section.

3.2 Terms and definitions for preparation of test assemblies by electrofusion

3.2.1

reference time

t_R
theoretical fusion time indicated by the fitting manufacturer for the reference ambient temperature

NOTE See Annex B.

3.2.2

fusion energy

electrical energy supplied during the fusion-jointing cycle as measured at the terminals of the fitting at a given ambient temperature, T_a , and for electrical parameters whose values lie within the tolerance ranges declared by the manufacturer

NOTE 1 The fitting manufacturer is generally required to state in the technical file any variations in fusion energy input required as a function of the ambient temperature in the range T_{min} to T_{max} .

NOTE 2 Where applicable, energy measurement should exclude the effect of terminal contact resistance.

NOTE 3 See Annex B.

3.2.3

reference energy

energy supplied to a fitting having a nominal electrical resistance and using the nominal fusion parameters defined by the manufacturer at the reference ambient temperature, T_R

NOTE See Annex B.

3.2.4

maximum energy

maximum value of the fusion energy supplied for jointing at a given ambient temperature, T_a

NOTE See Annex B.

3.2.5

minimum energy

minimum value of the fusion energy supplied for jointing at a given ambient temperature, T_a

NOTE See Annex B.

3.2.6

nominal energy

nominal energy supplied for jointing at given ambient temperature, T_a

NOTE See Annex B.

3.2.1 Symbols

Application	Symbol	Description	Unit
Symbols used in more than one phase of the fusion-jointing cycle^a	e_n	nominal pipe wall thickness	mm
	d_n	nominal external diameter of the pipe	
	p	pressure applied to the butt fusion joint interface	
	t	duration of each phase in the fusion cycle	
	T_{nor}	normal temperature (23 ± 2) °C	°C
	T_{max}	maximum permissible ambient temperature	°C
	T_{min}	minimum permissible ambient temperature	°C
Symbols for joint geometry^a	Δ_a	misalignment between the pipes or fittings to be butt fused, expressed in terms of the difference, in millimetres, between, the external diameters	mm
	Δ_w	clearance between the fusion faces, expressed in terms of the gap, in millimetres, between the prepared faces	mm
Symbols for ambient temperature^{ab}	T_a	ambient temperature at which the joint is made	°C
Symbols butt fusion cycle parameters^a	T	heater-plate temperature, measured in the zone of the heater-plate surface in contact with the pipe or spigot ends to be butt fused	°C
— General			
	— Phase 1: heating		
	p_1	interface pressure during the heating phase, i.e. the pressure applied in the contact zone	MPa
	B_1	initial bead width taken as the bead width at the end of the heating phase	mm
	t_1	heating time, taken as the time necessary to obtain a bead of width B_1 in the joint region during the heating phase	s

ISO 16486-5:2012(E)

Application	Symbol	Description	Unit
— Phase 2: heat soak	p_2	pressure between the heater plate and the pipe or spigot ends during the heat soak phase	MPa
	t_2	duration of internal heating during the heat soak phase	s
— Phase 3: withdrawal of heater plate	t_3	time between the moment when the heater plate is removed from the pipe and/or spigot ends and the moment when the pipe and/or spigot ends are placed in contact with each other	s
— Phase 4: pressure increase	t_4	time required to establish the butt fusion pressure	s
— Phase 5: butt fusion	p_5	pressure applied to the contact zone during the butt fusion phase	MPa
	t_5	time during which the assembly remains under the butt fusion pressure in the machine	s
— Phase 6: cooling	t_6	cooling time during which the butt fused assembly is not subjected to any rough handling; this cooling can take place outside the machine	min
	B_2	bead width obtained at the end of the cooling phase	mm
Symbols for the preparation of test assemblies by electrofusion ^c	D_{im}	mean inside diameter of the fusion zone of a fitting in the radial plane located a distance $L_3 + 0,5L_2$ from the face of the fitting socket	mm
	$D_{i,max}$	maximum theoretical value of D_{im} as declared by the fitting manufacturer	mm
	$D_{i,max}$	maximum inside diameter of the fusion zone of the fitting	mm
	$D_{i,min}$	minimum inside diameter of the fusion zone of the fitting	mm
	d_e	outside diameter of a pipe or fitting spigot	mm
	d_{em}	mean outside diameter of a pipe or fitting spigot in conformance with ISO 16486-2 and ISO 16486-3, as applicable, and calculated from the measured circumference	mm
	d_{emp}	mean outside diameter of a pipe or fitting spigot after preparation for assembly with the outer layer removed by scraping or peeling and calculated from the circumference measured in a radial plane coincident with the centre of the fusion zone at a distance $L_3 + 0,5L_2$ from the face of the fitting socket after assembly	mm
	e_n	nominal wall thickness of the pipe	mm
	e_s	depth of scraping or the thickness of material removed from the pipe surface by peeling	mm
	L_2	nominal length of the fusion zone as indicated by the fitting manufacturer	mm
L_3	nominal distance from the face of the fitting socket to the leading edge of the fusion zone	mm	
<p>^a See Annex A.</p> <p>^b The ambient temperature may vary from the minimum temperature, T_{min}, to the maximum temperature, T_{max}, as defined by agreement between the manufacturer and the purchaser.</p> <p>^c See Figure B.1; see Annex B.</p>			

4 Fitness for purpose

4.1 Method of preparation of assemblies for testing

4.1.1 General

The joints shall be made by using pipes conforming to ISO 16486-2 or fittings conforming to ISO 16486-3.

Test pieces for pressure test shall be closed with pressure-tight, end-load-bearing end caps, plugs or flanges, which shall be provided with connections for the entry of water and release of air.

4.1.2 Butt fusion joints

PA-U pipes and spigot end fittings intended to be used for jointing by butt fusion shall be prepared and assembled in accordance with Annex A.

4.1.3 Electrofusion jointing

PA-U pipes and fittings intended to be used for jointing by electrofusion shall be prepared and assembled in accordance with Annex B.

For joints with electrofusion socket fittings and joints with electrofusion saddle fittings, test joints shall be prepared to check the fitness for purpose of the fittings under extreme jointing conditions.

For joints with electrofusion saddle fittings, the electrofusion saddle fitting shall be fused to the pipe, while it is pneumatically pressurized to the allowable maximum operating pressure. The pipe shall be cut immediately after the manufacturer-prescribed cooling time has elapsed.

These joints with electrofusion saddle fitting should be prepared taking national safety regulations into consideration.

For straight equal electrofusion socket fittings (couplers), test joints on selected diameters out of the product range shall be prepared with a gap of $0,05d_n$ between the pipe end and the maximum theoretical depth of penetration of the fitting, where for diameters greater than 225 mm, the adjoining pipes shall be arranged to provide the maximum angular deflection possible for the fitting, limited to $1,5^\circ$.

4.2 Requirements for fitness for purpose

4.2.1 Fitness for purpose for butt fusion joints

4.2.1.1 Under normal conditions — Ambient temperature 23°C

For the assessment of fitness for purpose under normal conditions, butt fusion joints shall have the characteristic of tensile strength conforming to the requirement given in Table 5, using the parameters as specified in Annex A, Table A.2 and Table A.3, at an ambient temperature of $(23 \pm 2)^\circ\text{C}$ and the scheme listed in Table 1.

ISO 16486-5:2012(E)

Table 1 — Scheme for butt fusion joints

Pipe/spigot end fitting	Pipe			
	PA-U 11 160	PA-U 11 180	PA-U 12 160	PA-U 12 180
PA-U 11 160	X	X ^a	Jointing not allowed	Jointing not allowed
PA-U 11 180	X ^a	X	Jointing not allowed	Jointing not allowed
PA-U 12 160	Jointing not allowed	Jointing not allowed	X	X ^a
PA-U 12 180	Jointing not allowed	Jointing not allowed	X ^a	X

The table should be interpreted as follows: as an example, for a pipe or a spigot end fitting made from a PA-U 11 160 compound, a joint should be tested with a pipe made from PA-U 11 160 compound. When requested by the purchaser or end user, for mixed compound joints, test pieces should be used incorporating PA-U 11 160 and PA-U 11 180 compounds.

^a Only when requested by the purchaser or end user.

The pipe manufacturer shall declare, according to 4.2.1.1, which pipes from his own product range conforming to ISO 16486-2 are compatible to each other for butt fusion.

The fitting manufacturer shall declare, according to 4.2.1.1 the SDR range and MRS values of pipes conforming to ISO 16486-2 to which his fittings conforming to ISO 16486-3 can be fused by using the same procedures (e.g. times, temperatures, fusion pressures) to conform to this part of ISO 16486. If there is a need for deviation in fusion procedures the fitting manufacturer shall state this clearly.

4.2.1.2 Under extreme conditions

For butt fusion joints, the characteristics to be examined for fitness for purpose under extreme conditions shall conform to Table 2.

Table 2 — Relation between the joints and fitness for purpose characteristics

Butt fusion joint	Associated characteristics
Both components of the joint: same MRS and same SDR Joint: minimum and maximum condition ^a	Hydrostatic strength (80 °C, 165 h)
Both components of the joint: same MRS and same SDR Joint: minimum and maximum condition	Tensile strength for butt fusion joint

^a As specified in Annex A concerning misalignment [A.5 a)] and the limit values of fusion parameters (Table A.4).

When tested in accordance with the test methods as specified in Table 5 using the indicated parameters, the joints shall have characteristics conforming to the requirements given in Table 5.

The fitting manufacturer shall declare according to Table 2, as applicable, the fitness for purpose under extreme conditions of his fittings.

The pipe manufacturer shall declare according to Table 2 the fitness for purpose under extreme conditions of his pipes.

4.2.2 Fitness for purpose for electrofusion joints

4.2.2.1 Under normal conditions — Ambient temperature 23 °C

For the assessment of fitness for purpose under normal conditions, electrofusion joints shall have the characteristic of decohesive resistance or cohesive strength, as applicable, conforming to the requirement given in Table 5, using the assembly condition 1 as specified in Annex B, Table B.3, at an ambient temperature of (23 ± 2) °C and the scheme listed in Table 3.

Table 3 — Scheme for electrofusion joints

Electrofusion fitting with electrofusion socket	Pipe			
	PA-U 11 160 SDR maximum	PA-U 11 180 SDR minimum	PA-U 12 160 SDR maximum	PA-U 12 180 SDR minimum
PA-U 11 160	X	X ^a	Jointing not allowed	Jointing not allowed
PA-U 11 180	X ^a	X	Jointing not allowed	Jointing not allowed
PA-U 12 160	Jointing not allowed	Jointing not allowed	X	X ^a
PA-U 12 180	Jointing not allowed	Jointing not allowed	X ^a	X

The table should be interpreted as follows: as an example, for an electrofusion fitting made from a PA-U 11 160 compound, a joint should be tested with a pipe made from PA-U 11 160 compound and a SDR maximum and an other joint should be tested with a pipe made from PA-U 11 160 compound and a SDR minimum.

^a Only when requested by the purchaser or end user.

The fitting manufacturer shall declare, according to 4.2.2.1 the SDR range and MRS values of pipes conforming to ISO 16486-2 to which his fittings conforming to ISO 16486-3 can be fused by using the same procedures (e.g. times, temperatures, fusion pressures) to conform to this part of ISO 16486. If there is a need for deviation in fusion procedures the fitting or valve manufacturer shall state this clearly.

4.2.2.2 Under extreme conditions

For electrofusion joints the characteristics to be examined for fitness for purpose under extreme conditions shall conform to Table 4.

When tested in accordance with the test methods as specified in Table 5 using the indicated parameters, the joints shall have characteristics conforming to the requirements given in Table 5.

Table 4 — Relation between the joints and fitness for purpose characteristics

Electrofusion joint, including socket fitting ^a	Electrofusion joint, including saddle fitting ^a	Associated characteristic
Pipe: MRS maximum ^b SDR minimum ^b Joint: conditions 2.2 and 3.2 of Table B.3 ^c		Decohesive resistance
	Pipe: MRS maximum ^b SDR minimum ^b Joint: conditions 2.2 and 3.2, of Table B.3 ^c	Cohesive strength

^a If accepted by the purchaser, the minimum and maximum energy conditions 2.2 and 3.2 may be replaced by a nominal energy at a given ambient temperature, T_a , defined by the fitting manufacturer (see 3.2.6).
^b As declared by the fitting manufacturer according to 4.2.2.1.
^c As specified in Table B.3 of Annex B with T_{min} and T_{max} as stated in the fitting manufacturer's technical specification.

The fitting manufacturer shall declare according to Table 4, as applicable, the fitness for purpose under extreme conditions of his fittings.

ISO 16486-5:2012(E)

Table 5 — Characteristics for fitness for purpose of the system

Characteristic	Requirements	Test parameters Parameter	Value	Test method
Hydrostatic strength (80 °C, 165 h)	No failure during the test period of any test piece	End caps Orientation Conditioning time Type of test Circumferential (hoop) stress PA-U 11 160 and PA-U 12 160 PA-U 11 180 and PA-U 12 180 Test period Test temperature	Type A Free 6 h Water-in-water 10,0 MPa 11,5 MPa 165 h 80 °C	ISO 1167-1 ISO 1167-4
Cohesive resistance for electrofusion socket fittings	Length of initiation rupture $\leq L_2/3$ in brittle failure	Test temperature	23 °C	ISO 13954 or ISO 13955
Evaluation of ductility of fusion joint interface for electrofusion saddle fittings	Surface of rupture $L_d \leq 50\%$ $\leq 25\%$, brittle failure	Test temperature	23 °C	ISO 13956
Tensile strength for — butt fusion fittings — spigot end fittings	Test to failure: — ductile: pass — brittle: fail	Test temperature	23 °C	ISO 13953

4.2.3 Fitness for purpose for transition fittings

4.2.3.1 Leaktightness test

The transition joint shall be leak free when leak tested at 0,5 bar and at a minimum of 1,5 MOP at both (23 ± 2) °C and (-29 ± 2) °C in accordance with C.3.

4.2.3.2 Leaktightness with temperature cycling

The transition joint shall be leak free after 10 temperature cycles as tested at 0,5 bar and a minimum of 1,5 MOP in accordance with C.5.

4.2.3.3 Leaktightness after tensile pull test

4.2.3.3.1 Transition joints in transition fittings and anodeless risers in PA-U sizes less than 110 mm shall be qualified under this requirement if the pipe is pulled to a minimum of 25 % elongation, as indicated by when the length of the unrestrained PA-U piping has been elongated to 125 % of its original length, when tested in accordance with C.4, and is bubble tight in accordance with 4.2.3.3.3. No leakage or pullout is permitted.

4.2.3.3.2 For PA-U sizes 110 mm and greater the joint shall be qualified by pull testing to tensile stress equal to or greater than the maximum tensile stress that would be produced by a temperature change of 38 °C when tested in accordance with C.4. No leakage or pullout is permitted in accordance with 4.2.3.3.3. Failure of one sample constitutes failure of this test.

4.2.3.3.3 The transition joint shall be leak tested at 0,5 bar and a minimum of 1.5 MOP, prior to and at the end of the test, while still under tensile load and immediately following the tensile test. No leakage shall be permitted when tested in accordance with C.4.

4.2.3.3.4 Each nominal size transition design, in PA-U shall be tested, except testing of the heaviest wall PA-U piping shall qualify all thinner wall PA-U pipe joints of the same outside diameter.

4.2.3.4 Leaktightness after constant tensile load (CTL) joint test

The transition joint shall be leak tested at 0,5 bar and a minimum of 1,5 MOP, prior to, at the end of the test while still under tensile load and immediately following the constant tensile load (CTL) joint test according to C.6. No leakage shall be permitted when tested in accordance with C.3.

Annex A (normative)

Preparation of test assemblies by butt fusion

A.1 General

This annex specifies a method for preparing butt fusion jointed test piece assemblies between PA-U pipes and spigot-ended fittings.

A.2 Pipes used for test assemblies

The pipes used for test assemblies shall be taken from straight lengths.

A.3 Conditioning

Condition the pipes used for test assemblies at temperature T_a (see Table A.3) for a period of time according to Table A.1.

Table A.1 — Conditioning periods

Thickness e_n mm	Minimum conditioning period h
$e_n < 3$	1
$3 \leq e_n < 8$	3
$8 \leq e_n < 16$	6
$16 \leq e_n < 32$	10
$32 \leq e_n$	16

A.4 Apparatus

The butt fusion machine used shall be fitted with an automatic fusion-pressure controller enabling the pressure to be kept constant during the whole of Phases 1, 2 and 5 of the fusion cycle.

A.5 Jointing procedure

Using straight pipes and fittings conforming to ISO 16486-2 and ISO 16486-3, as applicable, join the components as follows, deviations from the procedure being permitted to demonstrate improvements in joint performance (appearance or mechanical properties):

- Fix the pipes or fittings in the butt fusion machine in such a manner as to obtain a misalignment Δ_a of, at the most, 0,5 mm when $d_n < 200$ mm or at the most 0,1 e_n or 1 mm, whichever is the greater, when $d_n \geq 200$ mm.
- Prepare and plane the butt fusion faces by means of a planing machine to obtain a maximum clearance Δ_w of 0,3 mm when $d_n < 200$ mm or 0,5 mm when $d_n \geq 200$ mm.
- Perform the butt fusion using the parameters specified in Table A.2, repeating the procedure on fresh test assemblies while varying the parameters within the limits given in Table A.4.
- Proceed to the tests as given in this part of ISO 16486.

A.6 Butt fusion cycle and parameters

Figure A.1 illustrates the butt fusion cycle and Tables A.2 and A.3 gives reference values for the parameters in each phase.

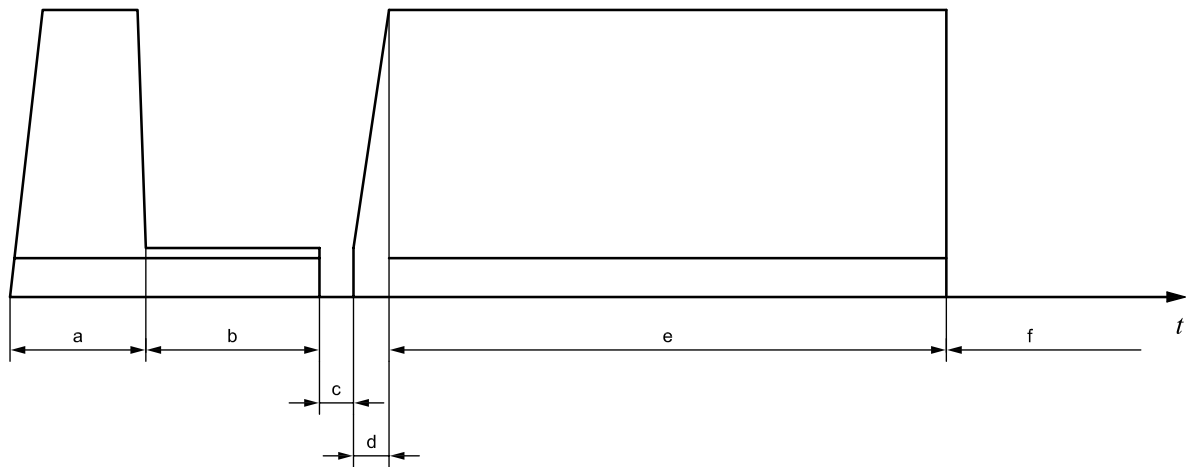

Key

- t time
- a Phase 1.
- b Phase 2.
- c Phase 3.
- d Phase 4.
- e Phase 5.
- f Phase 6.

Figure A.1 — Butt fusion cycle

Table A.2 — Butt fusion cycle and parameters

Parameters		Values	Units
Heater-plate temperature, T		240 ± 20	$^{\circ}\text{C}$
Phase 1	Pressure, p_1^a	$0,3 \pm 0,1$	MPa
	Time, t_1	Measured as the time until B_1 is reached	s
	Bead width, B_1	See Table A.3	mm
Phase 2	Pressure, p_2^a	$0,03 \pm 0,02$	MPa
	Time, t_2	See Table A.3	s
Phase 3	Time, t_3	See Table A.3	s
Phase 4	Time, t_4	See Table A.3	s
Phase 5	Pressure, p_5^a	$0,3 \pm 0,1$	MPa
	Time, t_5	See Table A.3	min
Phase 6	Time, t_6	Minimum value: $1,5e_n$	min
		Maximum value: 20	min

^a This pressure is the interface pressure and is related to d_n , e_n and the butt fusion equipment used.

ISO 16486-5:2012(E)

Table A.3 — Wall thickness dependant butt fusion parameters^a

Wall thickness e_n mm	B_1 mm	t_2 s	t_3 s	t_4 s	t_5 min
$\leq 4,5$	0,5	45	5	5	6
$4,5 < e_n \leq 7$	1,0	45 to 70	5 to 6	5 to 6	6 to 10
$7 < e_n \leq 12$	1,5	70 to 120	6 to 8	6 to 8	10 to 16
$12 < e_n \leq 19$	2,0	120 to 190	8 to 10	8 to 11	16 to 24
$19 < e_n \leq 26$	2,5	190 to 260	10 to 12	11 to 14	24 to 32
$26 < e_n \leq 37$	3,0	260 to 370	12 to 16	14 to 19	32 to 45

^a If other parameters are considered, they have to be agreed between the pipe/fitting manufacturer and the end-user.

Table A.4 gives the limits placed on the values of the parameters used in evaluating the jointing procedure.

Table A.4 — Limits on values of butt fusion parameters

Set of conditions	Conditions	Ambient temperature		Heater plate temperature, T °C	Butt fusion pressure, p N/mm ²
		Symbol	Value, °C		
1	Normal	T_{nor}	23 ± 2	240 ± 5	$0,3 \pm 0,02$
2	Minimum	T_{min}	0 ± 2	225 ± 5	$0,4 \pm 0,02$
3	Maximum	T_{max}	40 ± 2	255 ± 5	$0,3 \pm 0,02$

Annex B (normative)

Preparation of test assemblies by electrofusion

B.1 General

This annex specifies a method for the preparation of test pieces assembled from PA-U pipes or spigot-ended fittings and electrofusion fittings.

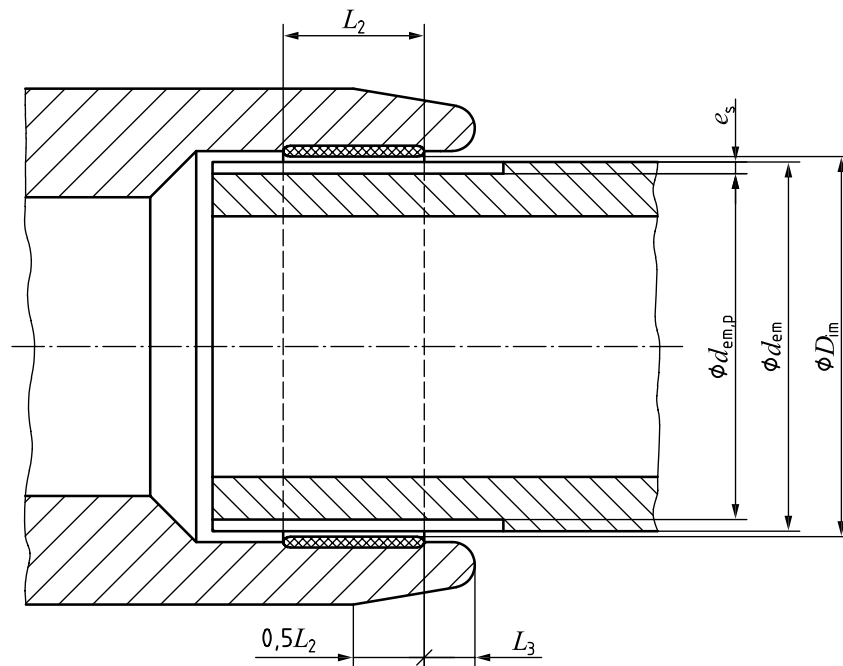

Key

D_{im}	$= (D_{i,max} + D_{i,min})/2$
d_{em}	$= C/\pi$ where C is the circumference of the unscraped pipe
d_{emp} (by analogy)	$= C_p/\pi$ where C_p is the circumference of the pipe to be assembled with the fitting
e_s	$= (d_{em} - d_{emp})/2$
L_2	nominal length of the fusion zone
L_3	length of the unheated section of the socket

Figure B.1 — Dimensions of an electrofusion socket

ISO 16486-5:2012(E)

B.2 Clearances

B.2.1 Socket fittings

C_1 , the clearance between fitting bore and outside diameter of unscraped pipe, is given by Formula (B.1):

$$C_1 = D_{im} - d_{em} \quad (\text{B.1})$$

C_2 , the clearance between fitting bore and outside diameter of scraped pipe, is given by Formula (B.2):

$$C_2 = C_1 + 2 e_s \quad (\text{B.2})$$

NOTE 1 C_2 can be obtained by machining the unscraped pipe to bring its mean outside diameter d_{em} to the value d_{emp} calculated from the Formula (B.3), see B.3.1, third paragraph.

$$d_{emp} = D_{im} - C_2 \quad (\text{B.3})$$

C_3 , the maximum theoretical clearance between fitting bore and outside diameter of unscraped pipe, is given by Formula (B.4):

$$C_3 = D_{im,max} - d_e \quad (\text{B.4})$$

C_4 , the maximum theoretical clearance between fitting bore and outside diameter of scraped pipe, is given by Formula (B.5):

$$C_4 = C_3 + 2 e_s \quad (\text{B.5})$$

NOTE 2 C_4 may be obtained by machining the unscraped pipe to bring its mean outside diameter d_{em} to the value d_{emp} calculated from Formula (B.6):

$$d_{emp} = D_{im} - C_4 \quad (\text{B.6})$$

B.2.2 Saddles

The clearance between saddle fittings and pipes is assumed to be zero.

B.2.3 Ambient temperature

T_a ambient temperature at which a joint is made

The ambient temperature may vary from the minimum temperature, T_{min} , to the maximum temperature T_{max} , as specified by agreement between the manufacturer and the purchaser.

T_R reference ambient temperature of (23 ± 2) °C;

T_{max} maximum permitted ambient temperature for joint assembly;

T_{min} minimum permitted ambient temperature for joint assembly.

B.2.4 Determination of fusion-jointing electrical parameters

NOTE Using the voltage tolerances specified in ISO 12176-2 [1].

B.2.4.1 Maximum energy input at ambient temperature, T_a

For control boxes using voltage control, the applied voltage is given by Formula (B.7):

$$V_{\max} \sqrt{\frac{R}{R_{\min}}} \quad (\text{B.7})$$

where

V_{\max} is the maximum control-box output voltage, in volts (nominal + tolerance);

R_{\min} is the manufacturer's stated minimum fitting resistance, in ohms, at T_R ;

R is the resistance, measured using a four-arm resistance bridge with the performance characteristics specified in Table B.1, of the fitting conditioned at the ambient temperature, T_a , specified for jointing.

B.2.4.2 Minimum energy input at ambient temperature, T_a

For control boxes using voltage control, the applied voltage is given by Formula (B.8):

$$V_{\min} \sqrt{\frac{R}{R_{\max}}} \quad (\text{B.8})$$

where

V_{\min} is the minimum control-box output voltage, in volts (nominal - tolerance);

R_{\max} is the manufacturer's stated maximum fitting resistance, in ohms, at T_R ;

R is the resistance, measured using a four-arm resistance bridge with the performance characteristics specified in Table B.1, of the fitting conditioned at the ambient temperature, T_a , specified for jointing.

The procedure for measuring the coil resistance implies the use of measuring equipment at the reference ambient temperature of $(23 \pm 2)^\circ\text{C}$, conditioning of the fitting at T_{\max} or T_{\min} and measurement of the resistance of the coil of the fitting within 30 s of removal from the conditioning enclosure.

Table B.1 — Resistance-bridge performance characteristics

Range	Resolution	Accuracy
Ω	$\text{m}\Omega$	
0 to 1	0,1	0,25 % of reading
0 to 10	1	0,25 % of reading
0 to 100	10	0,25 % of reading

B.3 Joint assembly

B.3.1 General

The joints shall be made using pipes and/or spigot-ended fittings conforming to ISO 16486-2 and ISO 16486-3, as applicable, and electrofusion fittings for which the dimensions conform to ISO 16486-3. The preparation of the assembly for testing shall be carried out in accordance with the electrofusion fitting manufacturer's written procedures.

Unless a greater scraping depth is recommended by the manufacturer, the minimum scraping depth e_s shall be 0,2 mm.

NOTE In cases where the pipes do not need to be scraped, the minimum scraping depth e_s may be zero.

ISO 16486-5:2012(E)

B.3.2 Procedure

Carry out the following procedure, where steps d) and f) shall be carried out in a temperature-controlled environment maintaining the temperature to within ± 2 °C and large enough to contain the fitting, the pipes and the holding apparatus. Fittings shall not be used within 170 h of manufacture.

- a) Measure, at the reference temperature T_R , the parts to be joined to determine the dimensional characteristics defined in 3.3 (symbols for the preparation of test assemblies by electrofusion) and illustrated in Figure B.1.
- b) Prepare the pipes to achieve the necessary clearance conditions, at the reference temperature T_R , as given in B.2.
- c) Mount the fitting on the pipes in accordance with the manufacturer's instructions.
- d) Condition the assembly and the associated apparatus for a period conforming to Table B.2 at the applicable ambient temperature, T_a , specified in Table B.3.

Table B.2 — Conditioning periods

Nominal wall thickness e_n mm	Minimum conditioning period h
$e_n < 3$	1
$3 \leq e_n < 8$	3
$8 \leq e_n < 16$	6
$16 \leq e_n < 32$	10
$32 \leq e_n$	16

- e) After conditioning, measure the resistance of the heating coil and determine the values of the electrical parameters in accordance with Table B.3 and B.2.4. The procedure for measuring the coil resistance implies the use of measuring equipment at the reference ambient temperature, T_R , with the fitting at the conditioning temperature.
- f) With the assembly conditioned at ambient temperature, T_a , carry out the fusion jointing in accordance with the fitting manufacturer's instructions at the energy levels indicated in Table B.3.
- g) Leave the joint to cool until it reaches ambient temperature.
- h) Proceed to the tests as given in this part of ISO 16486.

Table B.3 — Conditions for pipe and fitting preparation

Set of conditions	Ambient temperature, T_a	Pipe configuration	Clearance ^a	Energy	Assembly load ^b
1	T_R	Coiled or straight pipe as supplied	C_2	reference	usual
2.1	T_{min}	Straight pipe	C_4	nominal	usual
2.2	T_{min}	Straight pipe	C_4	minimum	minimum
3.1	T_{max}	Straight pipe	C_2	nominal	usual
3.2	T_{max}	Straight pipe	C_2	maximum	maximum
4	T_{max}	Straight pipe	C_4	minimum	minimum
5	T_{min}	Coiled or straight pipe as supplied	C_2	maximum	maximum

NOTE Sets of conditions 1 to 5 are applicable to the energy profiles illustrated in Figures B.2 and B.3.

^a In the case of saddles, the clearance shall be considered to be zero.

^b Applicable to joints with saddles, where the load can be controlled.

B.4 Diagrammatic representation of variation in fusion energy with ambient temperature

Figures B.2 and B.3 illustrate different forms of energy profile (see also Table B.3).

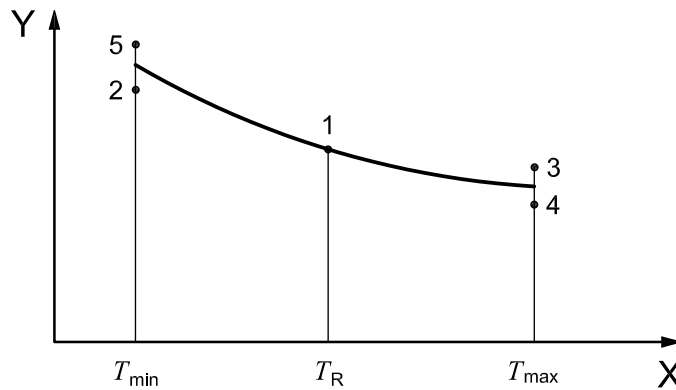

Key

- X temperature
- Y fusion energy

Figure B.2 — Profile with continuous adjustment of energy

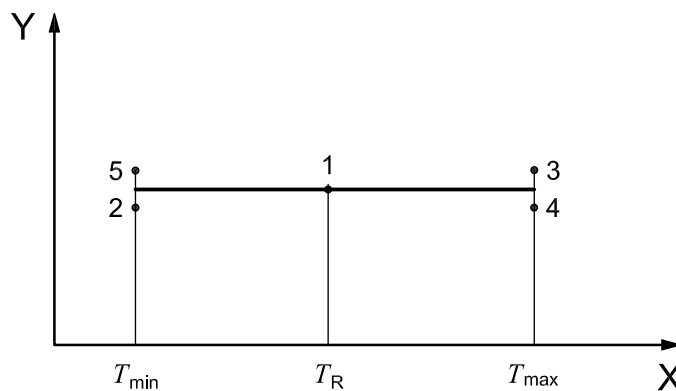

Key

- X temperature
- Y fusion energy

Figure B.3 — Constant-energy profile

Annex C (normative)

Test methods for the assessment of fitness for purpose of transition fittings

C.1 Test pieces

Unless otherwise specified by the applicable test method, six test specimens shall be tested.

C.2 Conditioning and test conditions

Unless otherwise specified by the applicable test method, the test pieces shall be conditioned for at least 16 h at 23 °C and 50 % relative humidity in accordance with ISO 291 before testing.

Unless otherwise specified by the applicable test method, the test procedure shall be carried out at (23 ± 2) °C.

C.3 Leaktightness testing

Pressurize the test specimen using air or other inert gas.

WARNING — For large diameter test specimens it is prudent to first fill the specimen with a coarse granular solid to reduce the pressurized volume of the sample. Plastic granules are frequently used for this purpose.

Ensure that all end caps and test fittings are bubble tight.

Detect leakage of the transition joint in accordance with the applicable test method. Conduct leak testing for 2 min.

C.4 Tensile pull testing

Affix the transition joint area of the transition fitting or anodeless riser in a tensile apparatus in accordance with ISO 6259-1 capable of subjecting the joint to a constant pull rate of (5 ± 25) % mm/min.

Tensile pull test the transition joint at a constant pull rate of (5 ± 25) % mm/min.

Return the tensile machine crosshead to the original position, remove the transition.

C.5 Temperature cycling testing

C.5.1 Conduct tests on six of the smallest and six of the largest nominal outlet pipe size of each transition design used in transition fittings or anodeless risers.

C.5.2 Leak test specimens at ambient temperature at 0,5 bar and a minimum of 1,5 MOP in accordance with C.3.

C.5.3 Condition test specimens to a temperature of (-29 ± 2) °C and maintain for a minimum of 2,5 h.

C.5.4 Condition specimens to a temperature of (60 ± 2) °C and maintain for a minimum of 2,5 h.

C.5.5 Repeat C.5.3 and C.5.4 for a total of 10 cycles.

C.5.6 After the tenth cycle is completed, pressurize 50 % of the test specimens of each size at 0,5 bar and the remaining 50 % of each size at 1.5 MOP of the piping material and SDR for which the transition fittings are designed to be used. Leak test first at (60 ± 2) °C and then at (-29 ± 2) °C. Condition the test specimen at leak test temperature for at least 4 h prior to testing.

C.6 Tensile testing under constant tensile load at 80 °C

C.6.1 For each transition joint, use PA-U pipe of length (not counting the transition fitting and the clamping jaws) equivalent to at least two times the nominal outside diameter of the pipe, but a maximum of 250 mm.

C.6.2 Mount the transition fitting assembly in a fixture capable of applying a constant longitudinal tensile force to the pipe(s) and fitting. The fitting shall be held in such a way that no distortion or support of any of the fitting components can occur.

C.6.3 Suspend the fitting assembly, subjected to a longitudinal force (end load) corresponding to a stress of 14,2 MPa at (80 ± 5) °C applied gradually within a time period of (5 ± 1) min and then maintained for 1 000 h.

Bibliography

- [1] ISO 12176-2, *Plastics pipes and fittings — Equipment for fusion jointing polyethylene systems — Part 2: Electrofusion*
- [2] ISO 17467 (all parts), *Plastics piping systems for the supply of gaseous fuels — Unplasticized polyamide (PA-U) piping systems jointed by solvent cement*
- [3] ISO 17135 (all parts), *Plastics piping systems for the supply of gaseous fuels — Plasticized polyamide (PA-P) piping systems with fusion jointing and mechanical jointing*

ISO 16486-5:2012(E)

ICS 75.200.00; 83.140.30

Price based on 20 pages

© ISO 2012 – All rights reserved