

# INTERNATIONAL STANDARD

# ISO 16462

First edition  
2004-06-15

---

---

## Cubic boron nitride inserts, tipped or solid — Dimensions, types

*Plaquettes en nitrure de bore cubique, brasées ou monobloc —  
Dimensions, types*



Reference number  
ISO 16462:2004(E)

© ISO 2004

**PDF disclaimer**

This PDF file may contain embedded typefaces. In accordance with Adobe's licensing policy, this file may be printed or viewed but shall not be edited unless the typefaces which are embedded are licensed to and installed on the computer performing the editing. In downloading this file, parties accept therein the responsibility of not infringing Adobe's licensing policy. The ISO Central Secretariat accepts no liability in this area.

Adobe is a trademark of Adobe Systems Incorporated.

Details of the software products used to create this PDF file can be found in the General Info relative to the file; the PDF-creation parameters were optimized for printing. Every care has been taken to ensure that the file is suitable for use by ISO member bodies. In the unlikely event that a problem relating to it is found, please inform the Central Secretariat at the address given below.

© ISO 2004

All rights reserved. Unless otherwise specified, no part of this publication may be reproduced or utilized in any form or by any means, electronic or mechanical, including photocopying and microfilm, without permission in writing from either ISO at the address below or ISO's member body in the country of the requester.

ISO copyright office  
Case postale 56 • CH-1211 Geneva 20  
Tel. + 41 22 749 01 11  
Fax + 41 22 749 09 47  
E-mail [copyright@iso.org](mailto:copyright@iso.org)  
Web [www.iso.org](http://www.iso.org)

Published in Switzerland

# Contents

Page

Foreword.....	iv
<b>1</b> <b>Scope</b> .....	<b>1</b>
<b>2</b> <b>Normative references</b> .....	<b>1</b>
<b>3</b> <b>Insert shapes and design</b> .....	<b>1</b>
<b>3.1</b> <b>Insert shapes</b> .....	<b>1</b>
<b>3.2</b> <b>Normal clearance <math>\alpha_n</math></b> .....	<b>1</b>
<b>3.3</b> <b>Cutting edge corner</b> .....	<b>1</b>
<b>3.4</b> <b>Tolerance class</b> .....	<b>2</b>
<b>3.5</b> <b>Design of cutting edges</b> .....	<b>2</b>
<b>3.6</b> <b>Insert type</b> .....	<b>2</b>
<b>4</b> <b>Designation</b> .....	<b>2</b>
<b>4.1</b> <b>General</b> .....	<b>2</b>
<b>4.2</b> <b>Designation of inserts for turning</b> .....	<b>2</b>
<b>4.3</b> <b>Designation of a tipped insert for milling</b> .....	<b>2</b>
<b>5</b> <b>Dimensions</b> .....	<b>3</b>
<b>5.1</b> <b>Insert shape T with fixing hole (inserts for turning)</b> .....	<b>3</b>
<b>5.2</b> <b>Insert shape S with fixing hole (inserts for turning)</b> .....	<b>5</b>
<b>5.3</b> <b>Insert shape C with fixing hole (inserts for turning)</b> .....	<b>6</b>
<b>5.4</b> <b>Insert shape D with fixing hole (inserts for turning)</b> .....	<b>7</b>
<b>5.5</b> <b>Insert shape V with fixing hole (inserts for turning)</b> .....	<b>8</b>
<b>5.6</b> <b>Insert shape S with fixing hole (inserts for milling)</b> .....	<b>9</b>
<b>5.7</b> <b>Insert shape C with fixing hole (inserts for milling)</b> .....	<b>10</b>
<b>5.8</b> <b>Insert shapes C, R, S and T without fixing hole (inserts for turning)</b> .....	<b>11</b>
<b>5.9</b> <b>Insert shapes S and T without fixing hole (inserts for milling)</b> .....	<b>13</b>
<b>5.10</b> <b>Insert shapes S and T without fixing hole (inserts for milling)</b> .....	<b>14</b>
<b>5.11</b> <b>Insert shape W with fixing hole (inserts for turning)</b> .....	<b>15</b>
<b>5.12</b> <b>Insert shape W without fixing hole (inserts for turning)</b> .....	<b>16</b>
<b>6</b> <b>Cutting edge length, <math>l_1</math>, of tipped inserts</b> .....	<b>17</b>
<b>6.1</b> <b>General</b> .....	<b>17</b>
<b>6.2</b> <b>Inserts with radius</b> .....	<b>17</b>
<b>6.3</b> <b>Inserts with wiper edge</b> .....	<b>17</b>
<b>7</b> <b>Base material, cutting material</b> .....	<b>18</b>
<b>8</b> <b>Measurements</b> .....	<b>18</b>
<b>9</b> <b>Marking</b> .....	<b>18</b>

## Foreword

ISO (the International Organization for Standardization) is a worldwide federation of national standards bodies (ISO member bodies). The work of preparing International Standards is normally carried out through ISO technical committees. Each member body interested in a subject for which a technical committee has been established has the right to be represented on that committee. International organizations, governmental and non-governmental, in liaison with ISO, also take part in the work. ISO collaborates closely with the International Electrotechnical Commission (IEC) on all matters of electrotechnical standardization.

International Standards are drafted in accordance with the rules given in the ISO/IEC Directives, Part 2.

The main task of technical committees is to prepare International Standards. Draft International Standards adopted by the technical committees are circulated to the member bodies for voting. Publication as an International Standard requires approval by at least 75 % of the member bodies casting a vote.

Attention is drawn to the possibility that some of the elements of this document may be the subject of patent rights. ISO shall not be held responsible for identifying any or all such patent rights.

ISO 16462 was prepared by Technical Committee ISO/TC 29, *Small tools*, Subcommittee SC 9, *Tools with cutting edges made of hard cutting materials*.

# Cubic boron nitride inserts, tipped or solid — Dimensions, types

## 1 Scope

This International Standard applies to inserts with insert shapes in accordance with ISO 883, ISO 3364, ISO 3365 and ISO 6987, tipped with cubic boron nitride (BL, BH, BC) or made of solid cubic boron nitride (BL, BH, BC).

## 2 Normative references

The following referenced documents are indispensable for the application of this document. For dated references, only the edition cited applies. For undated references, the latest edition of the referenced document (including any amendments) applies.

ISO 513, *Classification and application of hard cutting materials for metal removal with defined cutting edges — Designation of the main groups and groups of application*

ISO 883, *Indexable hardmetal (carbide) inserts with rounded corners, without fixing hole — Dimensions*

ISO 1832, *Indexable inserts for cutting tools — Designation*

ISO 3364, *Indexable hardmetal (carbide) inserts with rounded corners, with cylindrical fixing hole — Dimensions*

ISO 3365, *Indexable hardmetal (carbide) inserts with wiper edges, without fixing hole — Dimensions*

ISO 6987, *Indexable hard material inserts with rounded corners, with partly cylindrical fixing hole — Dimensions*

## 3 Insert shapes and design

### 3.1 Insert shapes

Triangular (T), square (S), rhombic 80° (C), 55° (D) and 35° (V), round (R), and trigon (W).

### 3.2 Normal clearance $\alpha_n$

Normal clearance 0° (N), 5° (B), 7° (C) and 11° (P).

### 3.3 Cutting edge corner

Inserts for turning with corner radius  $r_\epsilon$  0,2 mm; 0,4 mm; 0,8 mm; 1,2 mm and 1,6 mm.

Inserts for milling with wiper edge.

NOTE The design of non-tipped corners is optional.

### 3.4 Tolerance class

Tolerance class in accordance with ISO 1832 shall be applied. In Tables 1 to 12 this position is shown with a dot (•).

### 3.5 Design of cutting edges

Any design shall be indicated in the designation, see ISO 1832.

### 3.6 Insert type

The styles of tipped or solid cutting edges in accordance with ISO 1832 shall be applied.

## 4 Designation

### 4.1 General

The designation of inserts tipped or solid with cubic boron nitride (BL, BH, BC) is based on ISO 1832. The letter symbol for the cutting edge condition and the letter symbol for the insert type shall be indicated in the designation in each case.

Designations contained in 4.2 and 4.3 are examples of the use of designations in accordance with ISO 1832.

### 4.2 Designation of inserts for turning

#### 4.2.1 Solid insert (S)

Designation of a rhombic insert with included angle  $\varepsilon_r = 80^\circ$  (C), normal clearance  $\alpha_n = 0^\circ$  (N), with tolerance class M, without chip breakers and without fixing hole (N), with side length  $l = 9,67$  mm (09), thickness  $s = 3,18$  mm (03), corner radius  $r_\varepsilon = 0,8$  mm (08), without chamfered and rounded cutting edges (S), insert type solid (S), cutting material in accordance with ISO 513 (e.g. BL05):

**Insert CNMN 090308S — S — BL05 — ....**

NOTE BL05 is optional in accordance with ISO 1832, designation symbol 13.

#### 4.2.2 Insert, tipped — full thickness — one corner (T)

Designation of a rhombic insert with included angle  $\varepsilon_r = 55^\circ$  (D), normal clearance  $\alpha_n = 0^\circ$  (N), with tolerance class M, without chip breakers and with cylindrical fixing hole (A), with side length  $l = 15,5$  mm (15), thickness  $s = 4,76$  mm (04), corner radius  $r_\varepsilon = 0,8$  mm (08), with chamfered and rounded cutting edges (S), tipped — full thickness — one corner (T), long (L), cutting material in accordance with ISO 513 (e.g. BL05):

**Insert DNMA 150408S — TL — BL05 — ....**

NOTE BL05 is optional in accordance with ISO 1832, designation symbol 13.

### 4.3 Designation of a tipped insert for milling

Designation of a square insert (S) with normal clearance  $\alpha_n = 7^\circ$  (C), with tolerance class G, without chip breakers and with fixing hole (W), with side length  $l = 12,7$  mm (12), thickness  $s = 4,76$  mm (04), cutting edge angle  $\kappa_r = 75^\circ$  (E), normal clearance at wiper edge  $\alpha = 15^\circ$  (D), right-hand type (R), tipped — one side — one corner (A), long (L), cutting material in accordance with ISO 513 (e.g. BL05):

**Insert SCGW 1204EDR — AL — BL05 — ....**

NOTE BL05 is optional in accordance with ISO 1832, designation symbol 13.

## 5 Dimensions

### 5.1 Insert shape T with fixing hole (inserts for turning)

See Figure 1 and Table 1.

NOTE For the dimensions of  $l_1$ , see Table 13.

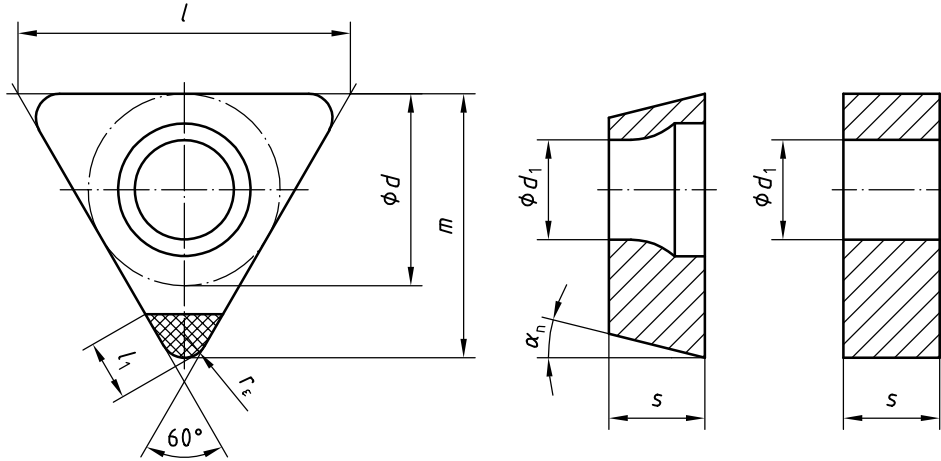

Figure 1

Table 1

Designation	$d$	$d_1$	$l$ $\approx$	$m$	$s$	$\alpha_n$	$r_\varepsilon$
TC•W 09 02 02S	5,56	2,5	9,63	8,137	2,38	7°	0,2
TC•W 09 02 04S	5,56	2,5	9,63	7,943	2,38	7°	0,4
TC•W 09 02 08S	5,56	2,5	9,63	7,541	2,38	7°	0,8
TC•W 11 02 02S	6,35	2,8	11	9,322	2,38	7°	0,2
TC•W 11 02 04S	6,35	2,8	11	9,128	2,38	7°	0,4
TC•W 11 02 08S	6,35	2,8	11	8,731	2,38	7°	0,8
TC•W 16 T3 02S	9,525	4,4	16,5	14,084	3,97	7°	0,2
TC•W 16 T3 04S	9,525	4,4	16,5	13,891	3,97	7°	0,4
TC•W 16 T3 08S	9,525	4,4	16,5	13,494	3,97	7°	0,8
TC•W 16 T3 12S	9,525	4,4	16,5	13,097	3,97	7°	1,2
TC•W 16 T3 16S	9,525	4,4	16,5	12,700	3,97	7°	1,6
TN•A 11 03 02S	6,35	2,26	11	9,322	3,18	0°	0,2
TN•A 11 03 04S	6,35	2,26	11	9,128	3,18	0°	0,4
TN•A 11 03 08S	6,35	2,26	11	8,731	3,18	0°	0,8
TN•A 16 04 04S	9,525	3,81	16,5	13,891	4,76	0°	0,4
TN•A 16 04 08S	9,525	3,81	16,5	13,494	4,76	0°	0,8
TN•A 16 04 12S	9,525	3,81	16,5	13,097	4,76	0°	1,2
TN•A 16 04 16S	9,525	3,81	16,5	12,700	4,76	0°	1,6
TP•W 08 02 02S	4,763	2,3	8,2	6,945	2,38	11°	0,2
TP•W 08 02 04S	4,763	2,3	8,2	6,747	2,38	11°	0,4
TP•W 08 02 08S	4,763	2,3	8,2	6,350	2,38	11°	0,8
TP•W 09 02 02S	5,56	2,5	9,63	8,137	2,38	11°	0,2
TP•W 09 02 04S	5,56	2,5	9,63	7,943	2,38	11°	0,4
TP•W 09 02 08S	5,56	2,5	9,63	7,541	2,38	11°	0,8
TP•W 11 02 02S	6,35	2,8	11	8,731	2,38	11°	0,2
TP•W 11 02 04S	6,35	2,8	11	8,137	2,38	11°	0,4
TP•W 11 02 08S	6,35	2,8	11	7,943	2,38	11°	0,8
TP•W 11 03 02S	6,35	3,3	11,0	9,327	3,18	11°	0,2
TP•W 11 03 04S	6,35	3,3	11,0	9,128	3,18	11°	0,4
TP•W 11 03 08S	6,35	3,3	11,0	8,731	3,18	11°	0,8
TP•W 16 03 04S	9,525	4,4	16,5	13,891	3,18	11°	0,4
TP•W 16 03 08S	9,525	4,4	16,5	13,494	3,18	11°	0,8
TP•W 16 T3 04S	9,525	4,4	16,5	13,891	3,97	11°	0,4
TP•W 16 T3 08S	9,525	4,4	16,5	13,494	3,97	11°	0,8
TP•W 16 T3 12S	9,525	4,4	16,5	13,097	3,97	11°	1,2
TP•W 16 T3 16S	9,525	4,4	16,5	12,700	3,97	11°	1,6
TP•W 16 04 04S	9,525	4,4	16,5	13,891	4,76	11°	0,4
TP•W 16 04 08S	9,525	4,4	16,5	13,494	4,76	11°	0,8



**5.2 Insert shape S with fixing hole (inserts for turning)**

See Figure 2 and Table 2.

NOTE For the dimensions of  $l_1$ , see Table 13.

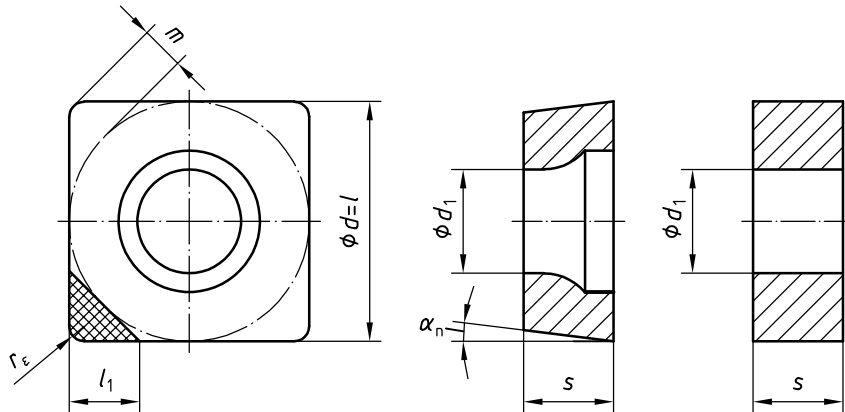

**Figure 2**

**Table 2**

Designation	$d$	$d_1$	$l$ $\approx$	$m$	$s$	$\alpha_n$	$r_\epsilon$
SC•W 09 T3 02S	9,525	4,4	9,525	1,889	3,97	7°	0,2
SC•W 09 T3 04S	9,525	4,4	9,525	1,808	3,97	7°	0,4
SC•W 09 T3 08S	9,525	4,4	9,525	1,644	3,97	7°	0,8
SC•W 09 T3 12S	9,525	4,4	9,525	1,479	3,97	7°	1,2
SC•W 12 04 04S	12,7	5,5	12,7	2,466	4,76	7°	0,4
SC•W 12 04 08S	12,7	5,5	12,7	2,301	4,76	7°	0,8
SC•W 12 04 12S	12,7	5,5	12,7	2,137	4,76	7°	1,2
SN•A 09 03 04S	9,525	3,81	9,525	1,808	3,18	0°	0,4
SN•A 09 03 08S	9,525	3,81	9,525	1,644	3,18	0°	0,8
SN•A 09 03 12S	9,525	3,81	9,525	1,479	3,18	0°	1,2
SN•A 12 04 04S	12,7	5,16	12,7	2,466	4,76	0°	0,4
SN•A 12 04 08S	12,7	5,16	12,7	2,301	4,76	0°	0,8
SN•A 12 04 12S	12,7	5,16	12,7	2,137	4,76	0°	1,2
SN•A 12 04 16S	12,7	5,16	12,7	1,972	4,76	0°	1,6

5.3 Insert shape C with fixing hole (inserts for turning)

See Figure 3 and Table 3.

NOTE For the dimensions of  $l_1$ , see Table 13.

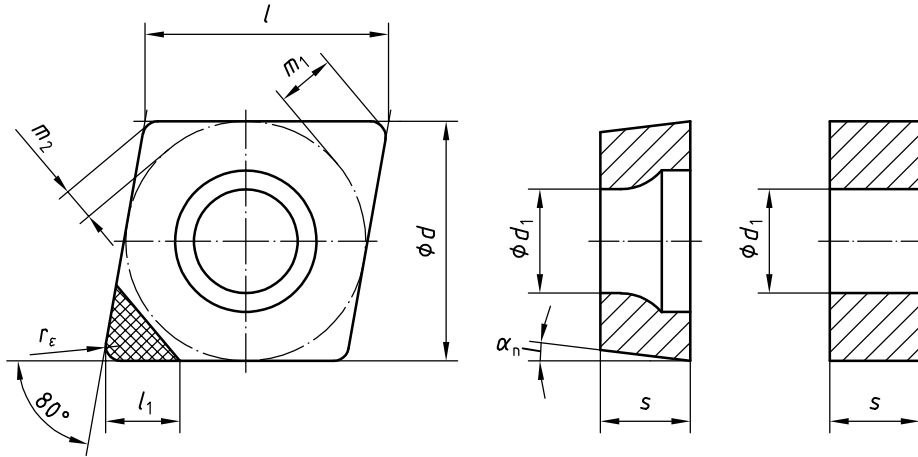

Figure 3

Table 3

Designation	$d$	$d_1$	$l$ $\approx$	$m_1$	$m_2$	$s$	$\alpha_n$	$r_\epsilon$
CC•W 06 02 02S	6,35	2,8	6,45	1,652	0,908	2,38	7°	0,2
CC•W 06 02 04S	6,35	2,8	6,45	1,544	0,848	2,38	7°	0,4
CC•W 06 02 08S	6,35	2,8	6,45	1,323	0,727	2,38	7°	0,8
CC•W 09 T3 02S	9,525	4,4	9,67	2,535	1,392	3,97	7°	0,2
CC•W 09 T3 04S	9,525	4,4	9,67	2,426	1,333	3,97	7°	0,4
CC•W 09 T3 08S	9,525	4,4	9,67	2,206	1,212	3,97	7°	0,8
CC•W 09 T3 12S	9,525	4,4	9,67	1,985	1,091	3,97	7°	1,2
CC•W 12 04 04S	12,7	5,5	12,9	3,308	1,818	4,76	7°	0,4
CC•W 12 04 08S	12,7	5,5	12,9	3,088	1,697	4,76	7°	0,8
CC•W 12 04 12S	12,7	5,5	12,9	2,867	1,576	4,76	7°	1,2
CC•W 12 04 16S	12,7	5,5	12,9	2,646	1,454	4,76	7°	1,6
CN•A 09 03 04S	9,525	3,81	9,67	2,426	1,333	3,18	0°	0,4
CN•A 09 03 08S	9,525	3,81	9,67	2,206	1,212	3,18	0°	0,8
CN•A 12 04 04S	12,7	5,16	12,9	3,308	1,818	4,76	0°	0,4
CN•A 12 04 08S	12,7	5,16	12,9	3,088	1,697	4,76	0°	0,8
CN•A 12 04 12S	12,7	5,16	12,9	2,867	1,576	4,76	0°	1,2
CN•A 12 04 16S	12,7	5,16	12,9	2,646	1,454	4,76	0°	1,6
CP•W 06 02 02S	6,35	2,8	6,45	1,652	0,908	2,38	11°	0,2
CP•W 06 02 04S	6,35	2,8	6,45	1,544	0,848	2,38	11°	0,4
CP•W 06 02 08S	6,35	2,8	6,45	1,323	0,727	2,38	11°	0,8
CP•W 09 03 02S	9,525	4,4	9,67	2,534	1,392	3,18	11°	0,2
CP•W 09 03 04S	9,525	4,4	9,67	2,426	1,333	3,18	11°	0,4
CP•W 09 03 08S	9,525	4,4	9,67	2,206	1,212	3,18	11°	0,8
CP•W 09 T3 02S	9,525	4,4	9,67	2,534	1,392	3,97	11°	0,2
CP•W 09 T3 04S	9,525	4,4	9,67	2,426	1,333	3,97	11°	0,4
CP•W 09 T3 08S	9,525	4,4	9,67	2,206	1,212	3,97	11°	0,8
CP•W 09 T3 12S	9,525	4,4	9,67	1,985	1,091	3,97	11°	1,2

**5.4 Insert shape D with fixing hole (inserts for turning)**

See Figure 4 and Table 4.

NOTE For the dimensions of  $l_1$ , see Table 13.

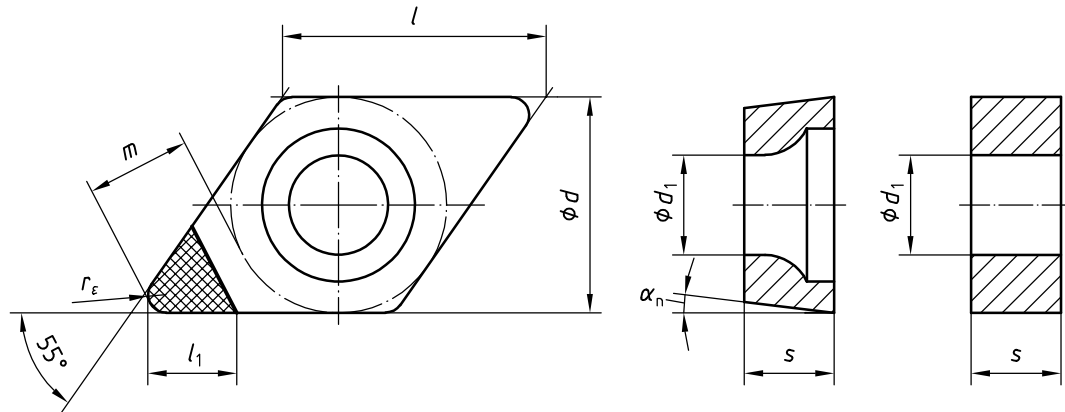

**Figure 4**

**Table 4**

Designation	$d$	$d_1$	$l$ $\approx$	$m$	$s$	$\alpha_n$	$r_\epsilon$
DC•W 07 02 02S	6,35	2,8	7,75	3,464	2,38	7°	0,2
DC•W 07 02 04S	6,35	2,8	7,75	3,238	2,38	7°	0,4
DC•W 07 02 08S	6,35	2,8	7,75	2,776	2,38	7°	0,8
DC•W 11 T3 02S	9,525	4,4	11,6	5,315	3,97	7°	0,2
DC•W 11 T3 04S	9,525	4,4	11,6	5,089	3,97	7°	0,4
DC•W 11 T3 08S	9,525	4,4	11,6	4,626	3,97	7°	0,8
DC•W 11 T3 12S	9,525	4,4	11,6	4,164	3,97	7°	1,2
DN•A 11 04 04S	9,525	3,81	11,6	5,089	4,76	0°	0,4
DN•A 11 04 08S	9,525	3,81	11,6	4,626	4,76	0°	0,8
DN•A 15 04 04S	12,7	5,16	15,5	6,939	4,76	0°	0,4
DN•A 15 04 08S	12,7	5,16	15,5	6,477	4,76	0°	0,8
DN•A 15 04 12S	12,7	5,16	15,5	6,014	4,76	0°	1,2
DN•A 15 06 04S	12,7	5,16	15,5	6,939	6,35	0°	0,4
DN•A 15 06 08S	12,7	5,16	15,5	6,477	6,35	0°	0,8
DN•A 15 06 12S	12,7	5,16	15,5	6,014	6,35	0°	1,2
DN•A 15 06 16S	12,7	5,16	15,5	5,551	6,35	0°	1,6

5.5 Insert shape V with fixing hole (inserts for turning)

See Figure 5 and Table 5.

NOTE For the dimensions of  $l_1$ , see Table 13.

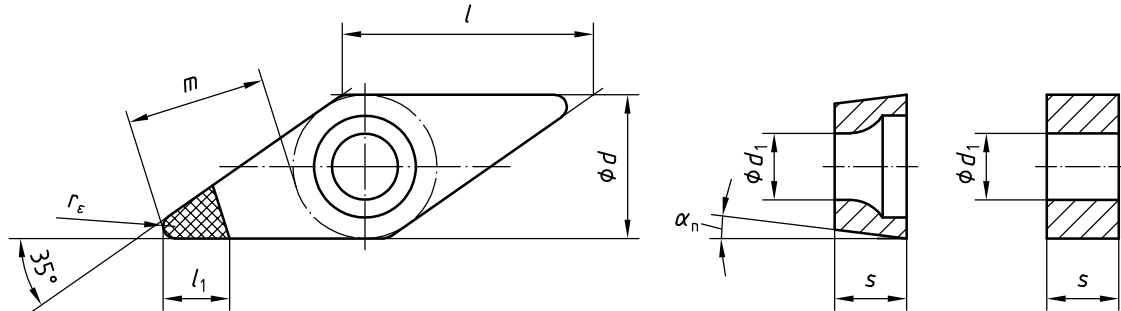

Figure 5

Table 5

Designation	$d$	$d_1$	$l$ $\approx$	$m$	$s$	$\alpha_n$	$r_\epsilon$
VC•W 11 03 02S	6,35	2,8	11,1	6,911	3,18	7°	0,2
VC•W 11 03 04S	6,35	2,8	11,1	6,460	3,18	7°	0,4
VC•W 11 03 08S	6,35	2,8	11,1	5,537	3,18	7°	0,8
VC•W 16 04 02S	9,525	4,4	16,6	10,603	4,76	7°	0,2
VC•W 16 04 04S	9,525	4,4	16,6	10,154	4,76	7°	0,4
VC•W 16 04 08S	9,525	4,4	16,6	9,231	4,76	7°	0,8
VC•W 16 04 12S	9,525	4,4	16,6	8,306	4,76	7°	1,2
VB•W 16 04 02S	9,525	4,4	16,6	10,602	4,76	5°	0,2
VB•W 16 04 04S	9,525	4,4	16,6	10,152	4,76	5°	0,4
VB•W 16 04 08S	9,525	4,4	16,6	9,229	4,76	5°	0,8
VB•W 16 04 12S	9,525	4,4	16,6	8,306	4,76	5°	1,2
VN•A 16 04 04S	9,525	3,81	16,6	10,152	4,76	0°	0,4
VN•A 16 04 08S	9,525	3,81	16,6	9,229	4,76	0°	0,8
VN•A 16 04 12S	9,525	3,81	16,6	8,306	4,76	0°	1,2

**5.6 Insert shape S with fixing hole (inserts for milling)**

See Figure 6 and Table 6.

NOTE For the dimensions of  $l_1$ , see Table 13.

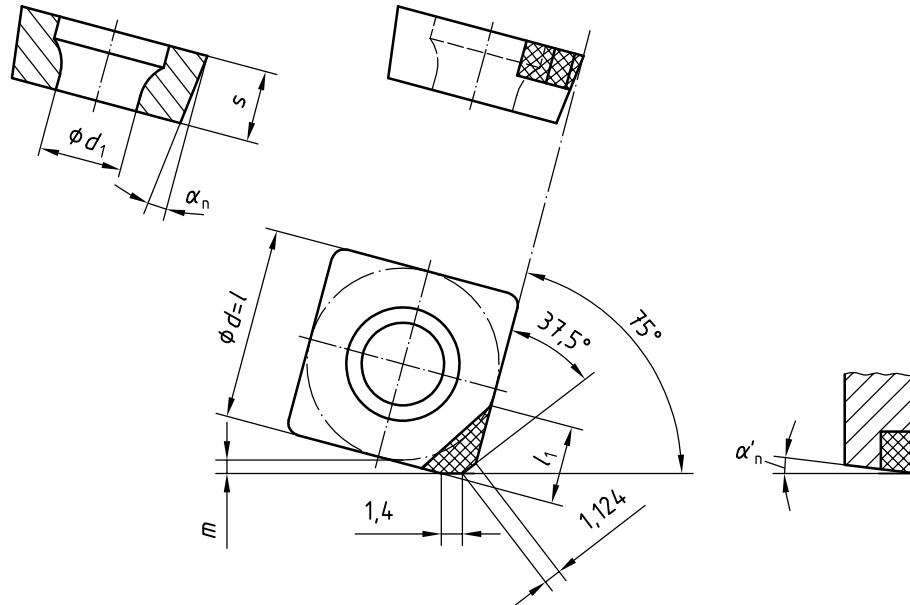

NOTE Right-hand type is shown in the figure (R).

**Figure 6**

**Table 6**

Designation	$d$	$d_1$	$l$ $\approx$	$m$	$s$	$\alpha_n$	$\alpha'_n$
SC•W 09 T3 ECR	9,525	4,4	9,525	0,543	3,97	7°	7°
SC•W 12 04 ECR	12,7	5,5	12,7	0,900	4,76	7°	7°
SP•W 09 T3 EDR	9,525	4,4	9,525	0,543	3,97	11°	15°
SP•W 12 04 EDR	12,7	5,5	12,7	0,900	4,76	11°	15°

5.7 Insert shape C with fixing hole (inserts for milling)

See Figure 7 and Table 7.

NOTE For the dimensions of  $l_1$ , see Table 13.

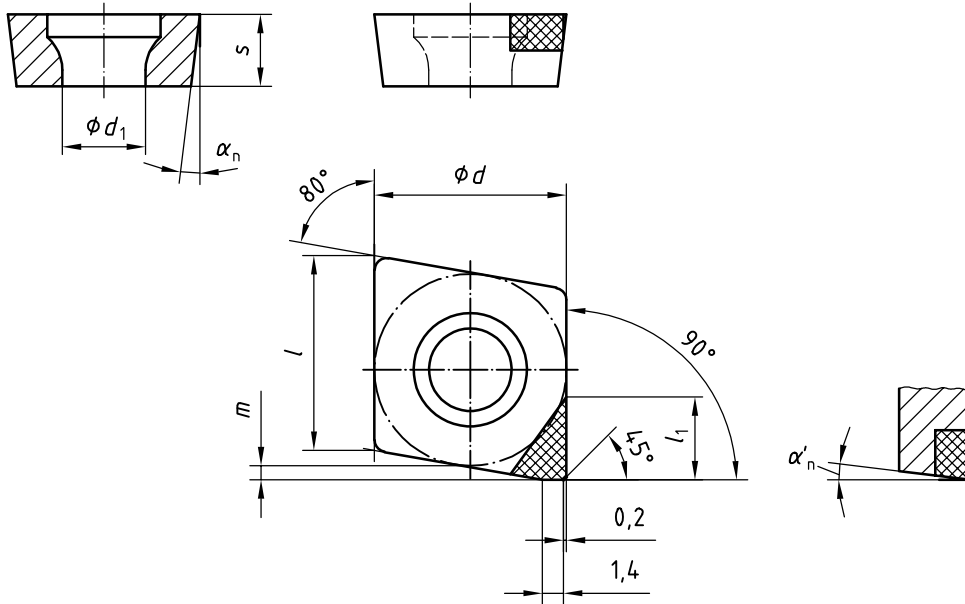

NOTE Right-hand type is shown in the figure (R).

Figure 7

Table 7

Designation	$d$	$d_1$	$l$ $\approx$	$m$	$s$	$\alpha_n$	$\alpha'_n$
CC•W 09 T3 PCR	9,525	4,4	9,67	0,631	3,97	7°	7°
CC•W 12 04 PCR	12,7	5,5	12,9	0,936	4,76	7°	7°
CP•W 09 T3 PDR	9,525	4,4	9,67	0,631	3,97	11°	15°
CP•W 12 04 PDR	12,7	5,5	12,9	0,936	4,76	11°	15°

5.8 Insert shapes C, R, S and T without fixing hole (inserts for turning)

See Figure 8 and Table 8.

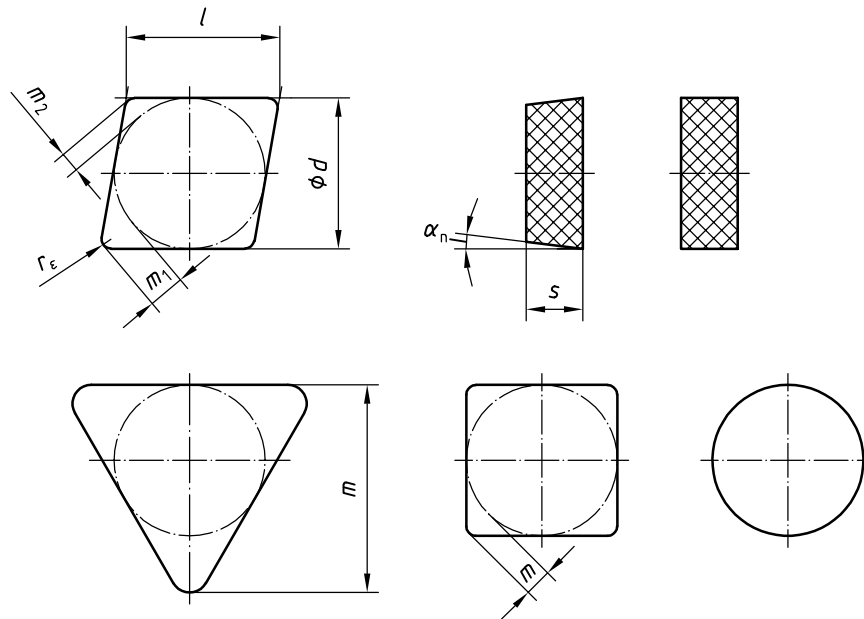

Figure 8

Table 8

Designation	$d$	$l$ $\approx$	$m$	$m_1$	$m_2$	$s$	$\alpha_n$	$r_\epsilon$
CN•N 09 03 04S	9,525	9,67	—	2,426	1,333	3,18	0°	0,4
CN•N 09 03 08S	9,525	9,67	—	2,206	1,212	3,18	0°	0,8
CN•N 09 03 12S	9,525	9,67	—	1,985	1,091	3,18	0°	1,2
CN•N 09 03 16S	9,525	9,67	—	1,764	0,970	3,18	0°	1,6
CN•N 12 04 04S	12,7	12,9	—	3,308	1,818	4,76	0°	0,4
CN•N 12 04 08S	12,7	12,9	—	3,088	1,697	4,76	0°	0,8
CN•N 12 04 12S	12,7	12,9	—	2,867	1,576	4,76	0°	1,2
CN•N 12 04 16S	12,7	12,9	—	2,646	1,454	4,76	0°	1,6
RC•N 09 03 00S	9,525	—	—	—	—	3,18	7°	—
RC•N 12 04 00S	12,7	—	—	—	—	4,76	7°	—
RN•N 09 03 00S	9,525	—	—	—	—	3,18	0°	—
RN•N 12 03 00S	12,7	—	—	—	—	3,18	0°	—
RN•N 12 04 00S	12,7	—	—	—	—	4,76	0°	—
SN•N 09 03 04S	9,525	9,525	1,808	—	—	3,18	0°	0,4
SN•N 09 03 08S	9,525	9,525	1,644	—	—	3,18	0°	0,8
SN•N 09 03 12S	9,525	9,525	1,479	—	—	3,18	0°	1,2
SN•N 09 03 16S	9,525	9,525	1,315	—	—	3,18	0°	1,6
SN•N 12 03 04S	12,7	12,7	2,466	—	—	3,18	0°	0,4

Table 8 (continued)

Designation	$d$	$l$ $\approx$	$m$	$m_1$	$m_2$	$s$	$\alpha_n$	$r_\varepsilon$
SN•N 12 03 08S	12,7	12,7	2,301	—	—	3,18	0°	0,8
SN•N 12 03 12S	12,7	12,7	2,137	—	—	3,18	0°	1,2
SN•N 12 03 16S	12,7	12,7	1,972	—	—	3,18	0°	1,6
SN•N 12 04 04S	12,7	12,7	2,466	—	—	4,76	0°	0,4
SN•N 12 04 08S	12,7	12,7	2,301	—	—	4,76	0°	0,8
SN•N 12 04 12S	12,7	12,7	2,137	—	—	4,76	0°	1,2
SN•N 12 04 16S	12,7	12,7	1,972	—	—	4,76	0°	1,6
SP•N 09 03 04S	9,525	9,5	1,808	—	—	3,18	11°	0,4
SP•N 09 03 08S	9,525	9,5	1,644	—	—	3,18	11°	0,8
SP•N 09 03 12S	9,525	9,5	1,479	—	—	3,18	11°	1,2
SP•N 12 03 08S	12,7	12,7	2,301	—	—	3,18	11°	0,8
SP•N 12 03 12S	12,7	12,7	2,137	—	—	3,18	11°	1,2
SP•N 12 04 08S	12,7	12,7	2,301	—	—	4,76	11°	0,8
SP•N 12 04 12S	12,7	12,7	2,137	—	—	4,76	11°	1,2
SP•N 12 04 16S	12,7	12,7	1,973	—	—	4,76	11°	1,6
TB•N 06 01 02S	3,969	6,87	5,755	—	—	1,59	5°	0,2
TB•N 06 01 04S	3,969	6,87	5,557	—	—	1,59	5°	0,4
TB•N 06 01 08S	3,969	6,87	5,160	—	—	1,59	5°	0,8
TN•N 11 03 02S	6,35	11	9,322	—	—	3,18	0°	0,2
TN•N 11 03 04S	6,35	11	9,128	—	—	3,18	0°	0,4
TN•N 11 03 08S	6,35	11	8,731	—	—	3,18	0°	0,8
TN•N 11 03 12S	6,35	11	8,334	—	—	3,18	0°	1,2
TN•N 11 03 16S	6,35	11	7,937	—	—	3,18	0°	1,6
TN•N 16 04 04S	9,525	16,5	13,891	—	—	4,76	0°	0,4
TN•N 16 04 08S	9,525	16,5	13,494	—	—	4,76	0°	0,8
TN•N 16 04 12S	9,525	16,5	13,097	—	—	4,76	0°	1,2
TN•N 16 04 16S	9,525	16,5	12,700	—	—	4,76	0°	1,6
TP•N 11 03 04S	6,35	11	9,128	—	—	3,18	11°	0,4
TP•N 11 03 08S	6,35	11	8,731	—	—	3,18	11°	0,8
TP•N 11 03 12S	6,35	11	8,334	—	—	3,18	11°	1,2
TP•N 16 03 04S	9,525	16,5	13,891	—	—	3,18	11°	0,4
TP•N 16 03 08S	9,525	16,5	13,494	—	—	3,18	11°	0,8
TP•N 16 04 02S	9,525	16,5	14,089	—	—	4,76	11°	0,2
TP•N 16 04 04S	9,525	16,5	13,891	—	—	4,76	11°	0,4
TP•N 16 04 08S	9,525	16,5	13,494	—	—	4,76	11°	0,8
TP•N 16 04 12S	9,525	16,5	13,097	—	—	4,76	11°	1,2
TP•N 16 04 16S	9,525	16,5	12,700	—	—	4,76	11°	1,6



**5.9 Insert shapes S and T without fixing hole (inserts for milling)**

See Figure 9 and Table 9.

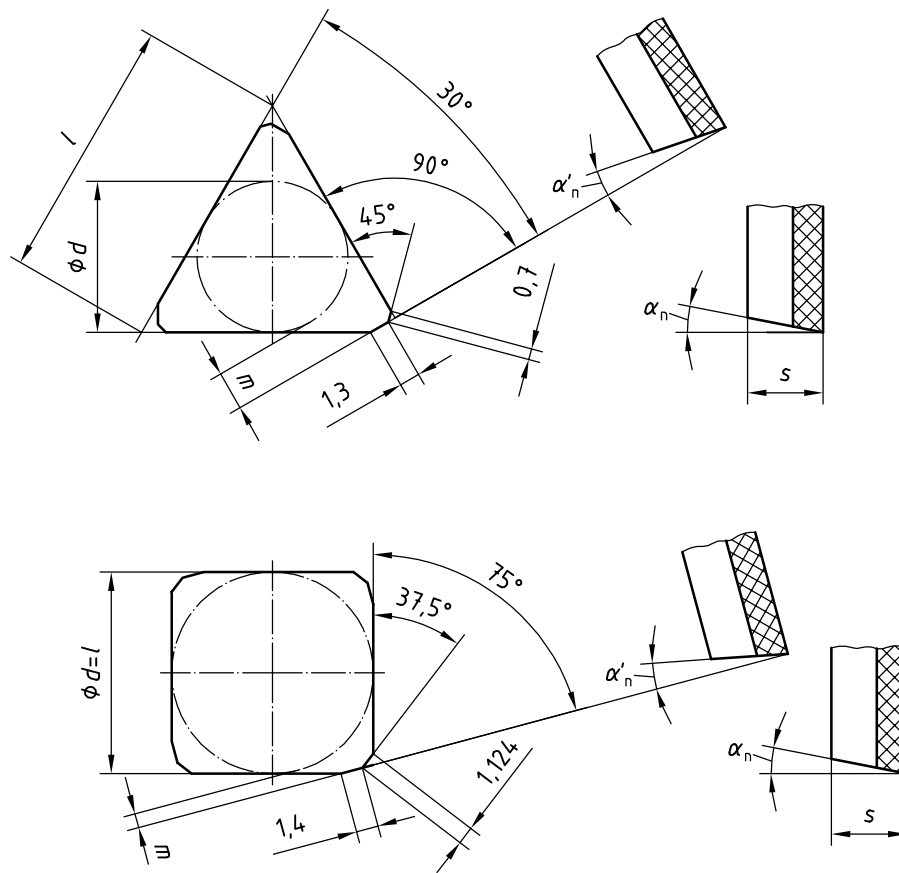

**Figure 9**

**Table 9**

Designation	$d$	$l$ $\approx$	$m$	$s$	$\alpha_n$	$\alpha'_n$
SN•N 09 03 ENR	9,525	9,525	0,543	3,18	0°	0°
SN•N 12 04 ENR	12,7	12,7	0,900	4,76	0°	0°
SP•N 09 03 EPR	9,525	9,525	0,543	3,18	11°	11°
SP•N 12 04 EPR	12,7	12,7	0,900	4,76	11°	11°
TN•N 11 03 PNR	6,35	11	1,288	3,18	0°	0°
TC•N 16 04 PCR	9,525	16,5	2,450	4,76	7°	7°
TP•N 16 04 PPR	9,525	16,5	2,450	4,76	11°	11°

5.10 Insert shapes S and T without fixing hole (inserts for milling)

See Figure 10 and Table 10.

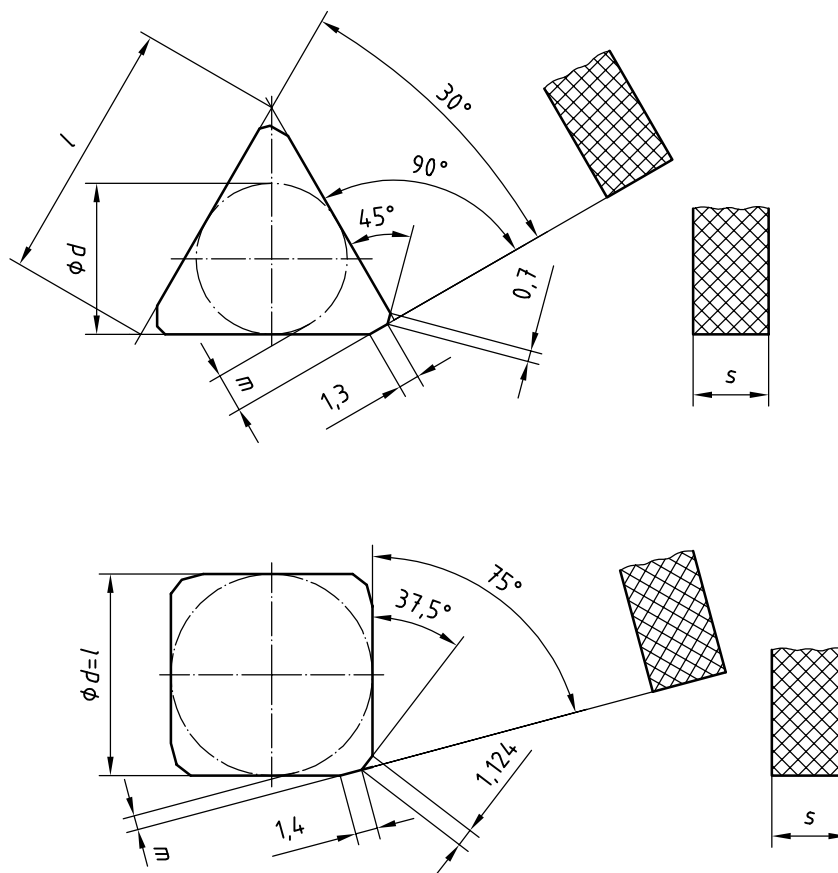

Figure 10

Table 10

Designation	$d$	$l$ $\approx$	$m$	$s$	$\alpha_n$
SN•N 09 03 EN	9,525	9,525	0,543	3,18	0°
SN•N 12 04 EN	12,7	12,7	0,900	4,76	0°
TN•N 11 03 PN	6,35	11	1,288	3,18	0°
TN•N 16 04 PN	9,525	16,5	2,450	4,76	0°

**5.11 Insert shape W with fixing hole (inserts for turning)**

See Figure 11 and Table 11.

NOTE For the dimensions of  $l_1$ , see Table 13.

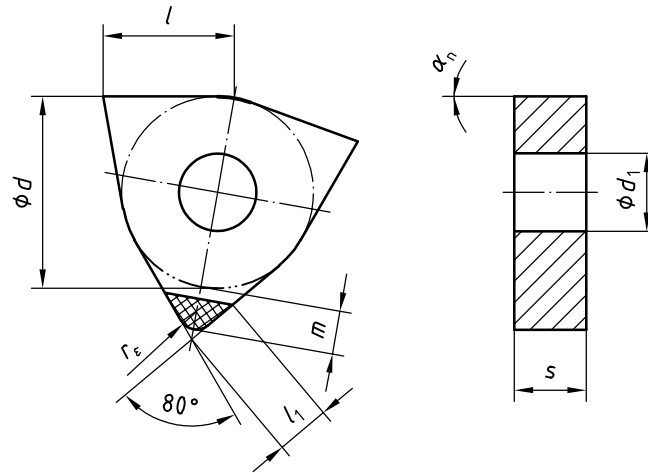

**Figure 11**

**Table 11**

Designation	$d$	$d_1$	$l$ $\approx$	$m$	$s$	$\alpha_n$	$r_\epsilon$
WN•A 06 04 04	9,525	3,81	6,52	2,426	4,76	0°	0,4
WN•A 06 04 08	9,525	3,81	6,52	2,203	4,76	0°	0,8
WN•A 06 04 12	9,525	3,81	6,52	1,980	4,76	0°	1,2
WN•A 08 04 04	12,7	5,16	8,69	3,307	4,76	0°	0,4
WN•A 08 04 08	12,7	5,16	8,69	3,084	4,76	0°	0,8
WN•A 08 04 12	12,7	5,16	8,69	2,862	4,76	0°	1,2

5.12 Insert shape W without fixing hole (inserts for turning)

See Figure 12 and Table 12.

NOTE For the dimensions of  $l_1$ , see Table 13.

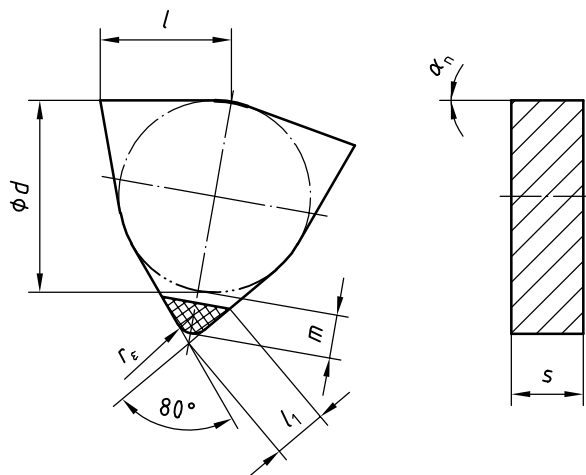

Figure 12

Table 12

Designation	$d$	$l$ $\approx$	$m$	$s$	$\alpha_n$	$r_\epsilon$
WN•N 06 04 04	9,525	6,52	2,426	4,76	0°	0,4
WN•N 06 04 08	9,525	6,52	2,203	4,76	0°	0,8
WN•N 06 04 12	9,525	6,52	1,980	4,76	0°	1,2
WN•N 08 04 04	12,7	8,69	3,307	4,76	0°	0,4
WN•N 08 04 08	12,7	8,69	3,084	4,76	0°	0,8
WN•N 08 04 12	12,7	8,69	2,862	4,76	0°	1,2

## 6 Cutting edge length, $l_1$ , of tipped inserts

### 6.1 General

$l_1$  is defined as the length along the major cutting edge from the end of the tip to the furthest point perpendicular to the major cutting edge.

### 6.2 Inserts with radius

See Figure 13.

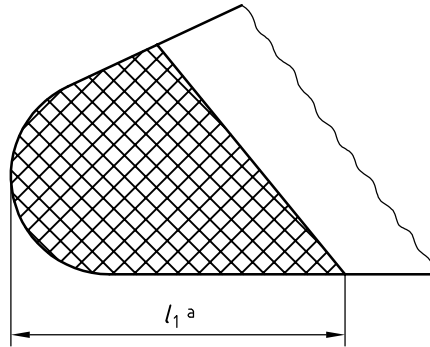

<sup>a</sup> For the dimensions of  $l_1$ , see Table 13.

Figure 13

### 6.3 Inserts with wiper edge

See Figure 14.

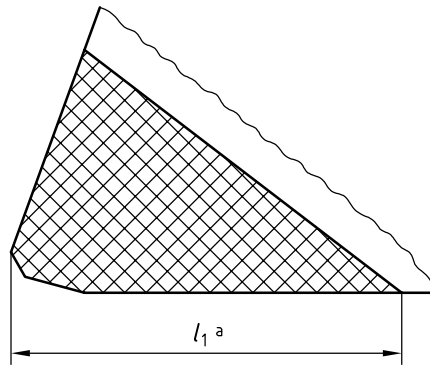

<sup>a</sup> For the dimensions of  $l_1$ , see Table 13.

Figure 14

Table 13

Cutting edge length	
$l_1$	
min	
short	long
0,8	3,0

## 7 Base material, cutting material

Base material is selected at the manufacturer's option or upon agreement.

Cutting edges made of BL, BH, BC are in accordance with ISO 513.

## 8 Measurements

Measurements are taken in accordance with ISO 3365 and ISO 6987.

## 9 Marking

Indexable inserts shall be visibly and durably marked with

- the symbol for the corner radius  $r_{\epsilon}$ ;
- the group of chip removal and group of application in accordance with ISO 513 or the cutting material grade;
- the name or trademark of the manufacturer.

Additional marking is at the manufacturer's option or upon agreement. Different marking is upon agreement.

If there is not sufficient space on the indexable insert to indicate the group of chip removal, group of application and the manufacturer's name, the insert can be marked with the manufacturer's cutting material grade instead. However, in such cases the group of chip removal and group of application shall be indicated clearly and visibly on the packaging.



---

---

**ICS 25.100.01**

Price based on 18 pages