**Refractory materials —
Determination of abrasion resistance
at elevated temperature**

*Matériaux réfractaires — Détermination de la résistance à l'abrasion
à température élevée*





COPYRIGHT PROTECTED DOCUMENT

© ISO 2015

All rights reserved. Unless otherwise specified, no part of this publication may be reproduced or utilized otherwise in any form or by any means, electronic or mechanical, including photocopying, or posting on the internet or an intranet, without prior written permission. Permission can be requested from either ISO at the address below or ISO's member body in the country of the requester.

ISO copyright office
Case postale 56 • CH-1211 Geneva 20
Tel. + 41 22 749 01 11
Fax + 41 22 749 09 47
E-mail copyright@iso.org
Web www.iso.org

Published in Switzerland

Contents

	Page
Foreword	iv
1 Scope	1
2 Normative references	1
3 Terms and definitions	1
4 Principle	1
5 Apparatus	1
6 Test pieces	5
6.1 General	5
6.2 Shaped refractories	5
6.3 Unshaped refractories	5
7 Procedure	5
8 Calculation	6
9 Test report	6
Annex A (informative) Determination of surface temperature of test pieces	7
Annex B (informative) The precision data of abrasion resistance	8

Foreword

ISO (the International Organization for Standardization) is a worldwide federation of national standards bodies (ISO member bodies). The work of preparing International Standards is normally carried out through ISO technical committees. Each member body interested in a subject for which a technical committee has been established has the right to be represented on that committee. International organizations, governmental and non-governmental, in liaison with ISO, also take part in the work. ISO collaborates closely with the International Electrotechnical Commission (IEC) on all matters of electrotechnical standardization.

The procedures used to develop this document and those intended for its further maintenance are described in the ISO/IEC Directives, Part 1. In particular the different approval criteria needed for the different types of ISO documents should be noted. This document was drafted in accordance with the editorial rules of the ISO/IEC Directives, Part 2 (see www.iso.org/directives).

Attention is drawn to the possibility that some of the elements of this document may be the subject of patent rights. ISO shall not be held responsible for identifying any or all such patent rights. Details of any patent rights identified during the development of the document will be in the Introduction and/or on the ISO list of patent declarations received (see www.iso.org/patents).

Any trade name used in this document is information given for the convenience of users and does not constitute an endorsement.

For an explanation on the meaning of ISO specific terms and expressions related to conformity assessment, as well as information about ISO's adherence to the WTO principles in the Technical Barriers to Trade (TBT), see the following URL: [Foreword — Supplementary information](#).

The committee responsible for this document is ISO/TC 33, *Refractories*.

Refractory materials — Determination of abrasion resistance at elevated temperature

1 Scope

This International Standard specifies a method for determination of abrasion resistance of shaped and unshaped refractory materials at elevated temperature. The test temperature is not intended to exceed 1 300 °C.

2 Normative references

The following documents, in whole or in part, are normatively referenced in this document and are indispensable for its application. For dated references, only the edition cited applies. For undated references, the latest edition of the referenced document (including any amendments) applies.

ISO 565, *Test sieves — Metal wire cloth, perforated metal plate and electroformed sheet — Nominal sizes of openings*

ISO 5017, *Dense shaped refractory products — Determination of bulk density, apparent porosity and true porosity*

ISO 16282:2007, *Methods of test for dense shaped refractory products — Determination of resistance to abrasion at ambient temperature*

3 Terms and definitions

For the purposes of this document, the following terms and definitions apply.

3.1

abrasion resistance at elevated temperature

ability of refractory test pieces to resist the surface wear caused by the mechanical action of moving solids with high speed at elevated temperature

4 Principle

The method determines the volume of material abraded from the flat surface of a test piece placed at right angles to a nozzle through which 1 000 g of size-graded silicon carbide is blasted by compressed air at 450 kPa at elevated temperature.

5 Apparatus

5.1 Abrasion tester, used for measuring the abrasion resistance of refractory test pieces at elevated temperature and consisting mainly of a blasting device, test furnace system, and other components (see [Figure 1](#)).

5.1.1 Blasting device.

The function of the venturi blast assembly and nozzle is the same as the expression of ISO 16282:2007, 5.1.1 and 5.1.2; the structure and parameters can be seen in ISO 16282:2007, Figure 1. The difference is that the glass tube of nozzle is replaced by alumina ceramic tube, and its length is 236 mm.

5.1.2 Compressed-air supply system.

5.1.2.1 Compressed-air supply, clean and dry, supplied to the blast assembly at the required pressure by means of a regulator.

5.1.2.2 Precise pressure gauge, with accuracy grade of 0,4 and a capacity of 0 kPa to 600 kPa.

The gauge is mounted as close to the blast assembly as possible.

5.1.3 Abrasive, consisting of silicon carbide with a particle-size distribution as given in [Table 1](#).

Before use, remove the material retained on the 850 µm ISO sieve and that passing the 300 µm ISO sieve.

Table 1 — Sieve analysis of the abrasive

Size of opening (ISO 565:— R 40/3) µm	Amount retained %
850	Trace
600	20 ± 2
300	80 ± 3
212	2 max.
< 212	Trace

NOTE This silicon carbide corresponds to FEPA grit size grade P36.

5.1.4 Abrasive feeding system, as shown in [Figure 1](#).

The charging funnel shall have a suitable orifice capable of delivering 1 000 g ± 5 g of abrasive into the delivery funnel within (900 ± 30) s. There shall be an interspace between the orifice and the delivery funnel to allow air to enter into the blast gun with abrasive.

5.1.5 Test furnace system, as shown in [Figure 1](#), consisting of the following parts.

5.1.5.1 Pressure regulating chamber.

The pressure regulating chamber is connected with the sample chamber and installs an exhaust vent to exhaust air. A dust collector is used on the exhaust vent to purify the air. A valve is attached on the vent to regulate the pressure inside the pressure regulating chamber. U-tape manometer is connected on the upper part of the chamber, for measuring the pressure inside the chamber.

5.1.5.2 Separating ring, made of corundum with 12 mm inside diameter.

The bottom interface of the nozzle is over the separating ring and there is some distance between them. The cold air and abrasive coming from the nozzle can be separated at the separating ring, the abrasive gets into the sample chamber through the separating ring and the cold air is excluded through the exhaust port mentioned in [5.1.5.1](#). The distance between the bottom interface of nozzle and the separating ring can regulate the pressure of sample chamber and make the pressure of sample chamber stable.

5.1.5.3 Protective tube, made of material able to withstand a temperature of 1 400 °C, with an inside hole of protective tube of the shape of a cone, 16 mm inside diameter of upper interface, 40 mm inside diameter of the bottom interface, and 125 mm in length.

The protective tube is embedded in the separating ring and enters the test furnace hearth through the furnace lining. The abrasive is blasted onto the test piece through the tube.

5.1.5.4 Sample chamber, airtight, conforming to the requirements specified in [7.3](#) and [7.4](#).

The temperature difference inside the furnace shall not exceed ± 10 °C. During the test period, the temperature drop of the test piece shall not exceed 20 °C (experimental method can be seen in [Annex A](#)). The heating guard plates used for protecting the heating element from blasting abrasive are set in the sample chamber.

The test piece is positioned on the test piece pedestal. The distance from the protective tube and the test piece can be regulated. Pressure gauge is connected on the upper part of the chamber, for measuring the pressure inside the chamber.

5.2 Volume testing device of test piece.

5.2.1 Balance, with a capacity of weighing 2 000 g, and an accuracy of 0,1 g.

5.2.2 Container with overflow pipe.

5.2.3 Evacuating equipment.

5.2.4 Immersion liquid.

5.2.5 Slot for immersion liquid.

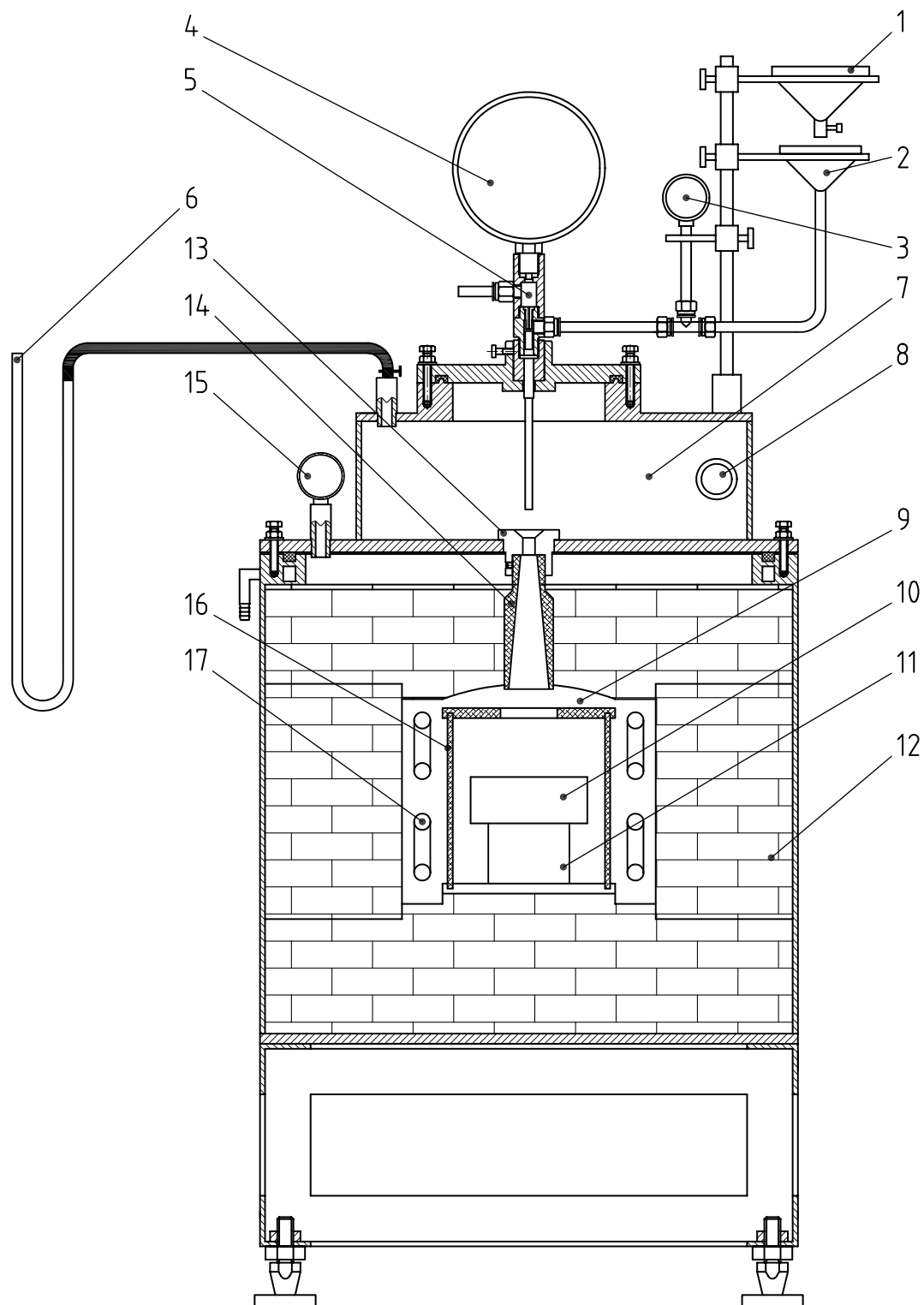

Key

- | | | | | | | | |
|---|------------------------|---|-----------------------------|----|---------------------|----|---------------------|
| 1 | charging funnel | 6 | U-type manometer | 10 | test piece | 14 | protective tube |
| 2 | delivery funnel | 7 | pressure regulating chamber | 11 | test piece pedestal | 15 | pressure gauge |
| 3 | vacuum gauge | 8 | exhaust vent | 12 | furnace wall | 16 | heating guard plate |
| 4 | precise pressure gauge | 9 | sample chamber | 13 | separating ring | 17 | heating element |
| 5 | blasting device | | | | | | |

Figure 1 — Schematic diagram of abrasion tester

6 Test pieces

6.1 General

The number of batches to be tested and the number of test pieces per batch shall be agreed between the parties and stated in the test report.

6.2 Shaped refractories

For all materials except the most abrasion-resistant, test pieces measuring 114 mm × 114 mm × (30 to 40) mm shall be cut from refractory bricks or shapes so that one of the square faces of each test piece is a flat surface. Test pieces measuring 100 mm × 100 mm × (25 to 40) mm may be used for the most abrasion-resistant materials. At least one of the square faces shall be a cut surface.

6.3 Unshaped refractories

Test pieces shall be prepared directly from the material used in the test, and then cut to the dimensions in [6.2](#) with at least one cut square face. The preparation procedure shall be agreed between the interested parties.

NOTE For unshaped refractories and unfired bricks, it is necessary to have this kind of test pieces pre-heated. The processing temperature is set by the abrasion test temperature, holding for 5 h. Other heat treatment conditions of test pieces require agreement between the parties.

7 Procedure

7.1 Dry the test pieces at 105 °C to 110 °C to constant weight.

7.2 Clean the test piece and measure its volume using the method given in ISO 5017.

The volume of the test piece should be calculated by the following formula, V_1 , in cubic centimetres.

$$V_1 = (m_3 - m_2) / \rho_{\text{liq}}$$

where

m_2 is the apparent mass of the immersed test piece, in grams;

m_3 is the mass of the soaked test piece, in grams;

ρ_{liq} is the density of the immersion liquid, in grams per cubic centimetres.

7.3 Place the test pieces in the sample chamber ([5.1.5.4](#)) with a square face (114 mm × 114 mm or 100 mm × 100 mm) perpendicular (at a 90° angle) to the protective tube ([5.1.5.3](#)) at a distance of 120 mm from it. The test surface should be a cut surface.

7.4 Shut the furnace door, switch on the power supply, raise the temperature from the ambient temperature to 1 000 °C at the rate of 5 °C/min to 8 °C/min, and from 1 000 °C to the test temperature at a rate of 3 °C/min to 5 °C/min, holding for 30 min at the testing temperature.

7.5 Turn on the compressed-air supply ([5.1.2.1](#)) and regulate the pressure to (450 ± 7) kPa. Check the vacuum degree inside the blast assembly by means of the vacuum gauge. If the vacuum gauge does not show a minimum pressure of 50 kPa, check the position of the corundum tube or the condition of the compressed-air supply.

7.6 Measure the pressure inside the pressure regulating chamber with a U-type manometer and maintain the pressure at 300 Pa (30,6 mm of water) by regulating the valve of the exhaust port while the pressure inside the sample chamber is 16 kPa.

7.7 Keep blasting compressed air, after the temperature of the sample chamber returns to the test temperature, reconnect the abrasive feed line and recheck the pressure of sample chamber (5.1.5.4) before placing (1 000 ± 5) g of dry abrasive in the charging funnel slowly. Connect the feed mechanism to the blast assembly. It shall deliver the abrasive within the specified time of (900 ± 30) s. After all abrasive has been delivered, switch off the power and allow the furnace to cool naturally.

7.8 Once the test piece has cooled, remove it from the sample chamber, blow off the dust and measure the volume of the test piece using the method in ISO 5017 (see 7.2).

7.9 Repeat the procedure with the next test piece. Use the abrasive only one time before discarding and replace the alumina ceramic tube of the nozzle every one test.

8 Calculation

Calculate the volume of material lost by abrasion from each test piece according to the following formula, A , in cubic centimetres:

$$A = V_1 - V_2$$

where

V_1 is the volume of the test piece before testing, in cubic centimetres;

V_2 is the volume of the test piece after testing, in cubic centimetres.

9 Test report

The test report shall include the following information:

- a) all information necessary for identification of the sample tested, including manufacturer, type, and batch number;
- b) a reference to this International Standard, i.e. ISO 16349;
- c) the name of the test establishment;
- d) the dimension of the test piece;
- e) the number of test piece;
- f) the testing temperature;
- g) for unshaped refractories, the conditions of preparation, including temperature of drying and treatment, etc., processes of the test piece;
- h) the results of the test, including the results of the individual determination and the mean value (cm³);
- i) the test operator and the date of the test.

Annex A (informative)

Determination of surface temperature of test pieces

According to the requirements of 5.1.5.4, the temperature drop of the test piece surface shall not exceed 20 °C during the test. In order to check whether the test furnace can meet the requirement, the temperature of test pieces can be measured using the following method.

Temperature measurement on the surface of test piece

In order to avoid damaging the thermocouple, the front side of thermocouple is positioned on the test piece with 40 mm distance from the blasting centre (see Figure A.1).

Dimensions in millimetres

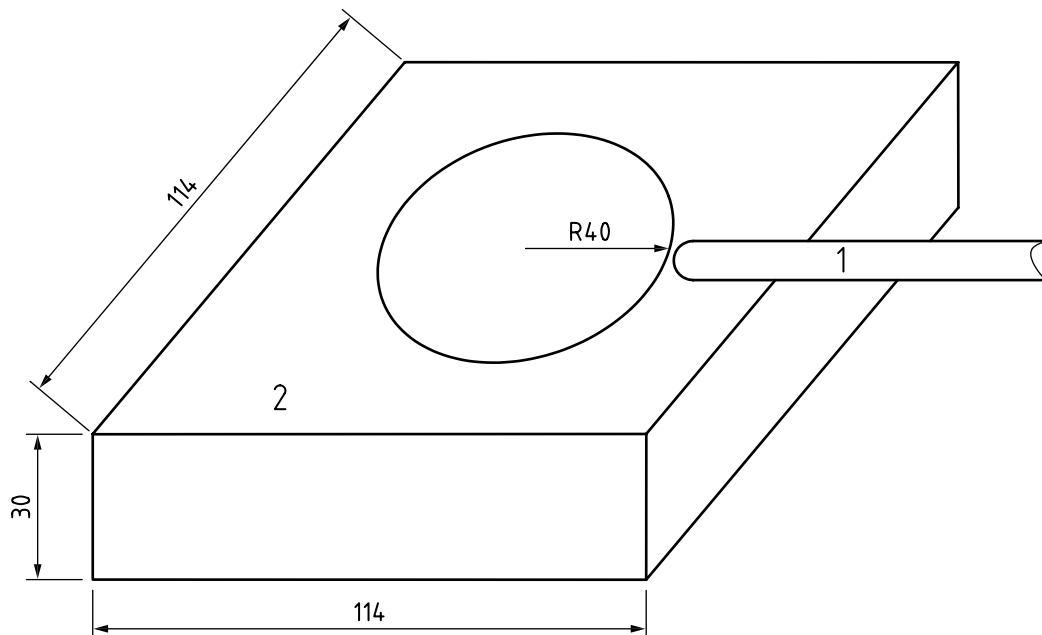

Key

- 1 thermocouple
- 2 test piece

Figure A.1 — Temperature measurement on the surface of test piece

Annex B (informative)

The precision data of abrasion resistance

An interlaboratory study was completed among eight laboratories. The specimens are quartz glass (with a density $2,20 \text{ g/cm}^3$) and high-alumina brick (with a density between $2,64 \text{ g/cm}^3$ and $2,71 \text{ g/cm}^3$, porosity between 14 % and 16 %). The testing temperature is $1\,000 \text{ }^\circ\text{C}$. The test data are listed in [Table B.1](#).

Table B.1 — The precision data of abrasion resistance

Material	Average value of abraded volume cm^3	Standard deviation within laboratories S_r	Standard deviation between laboratories S_R	Repeatability interval r	Reproducibility interval R	Relative repeatability $r\%$	Relative reproducibility $R\%$
High-alumina brick	8,4	1,15	1,22	3,22	3,42	38,33	40,71
Quartz glass	7,4	0,32	0,64	0,90	1,79	12,16	24,19

