

5.4 Temperature of key components

The temperature of the laser system and of the receiver system has an influence on the uncertainty of distance measurement. Most of these instruments have a built-in temperature compensation system to minimize this kind of influence.

5.5 Atmospheric influence

The maximum range and the accuracy of laser distance meters are influenced by meteorological conditions at the moment of the measurements being taken. These conditions include variations in air temperature, air pressure and humidity of the air. Distances calculated by handheld laser distance meters are based on predefined meteorological conditions. To achieve accurate measurements, in particular at long distances, these meteorological variables in the distance calculation shall be determined and the measured distance shall be corrected accordingly if the device under test offers this possibility.

5.6 Measurement resolution

The measurement resolution of a measurement instrument shall be at least two times better than the specified accuracy. For very accurate measurements, like in a calibration situation, a laser distance meter shall offer a unit setting which allows a measurement resolution that is at least five times better than the specified accuracy.

5.7 Average deviation and uncertainty of measurement

The typical user of handheld laser distance meters wants to take only one single measurement and wants to rely on the specified maximum tolerances. Therefore, it is the value of the combined and expanded uncertainty of a single measurement that the user wants to see below the tolerance limits.

5.8 Relevant contribution to uncertainty

Table 3 — Relevant contribution to uncertainty

Uncertainty contribution	Distribution	Type ^a
Reference system	Normal	B ^b
Measurement resolution	Rectangular	B
Absolute distance test (internal noise at typical conditions)	Normal	A
Background illumination (additional offset and noise)	Normal	A
Temperature (additional offset and noise)	Normal	A
^a For further information, refer to GUM "Guide to the Expression of Uncertainty in Measurement". ^b The uncertainty contribution of the "reference system" comprises a number of uncertainty contributions, including inter alia, contributions by the uncertainty of the length standard used, by the uncertainty due to an imperfect geometric alignment of reference and device under test or by the uncertainty due to imperfect temporal synchronization. All these contributions have to be carefully, individually assessed to quantify the overall uncertainty of the reference system.		

5.9 Instruction for instrument specifications

As customers of handheld laser distance meters usually are not used to the term "uncertainty of measurement", the manufacturers may use the expression "measurement accuracy" in their product specification.

Since the performance of a handheld laser distance meter depends on various conditions, the specification of the product shall indicate the conditions that apply, e.g. distance dependency,

target reflectivity, background illumination and temperature range. It is mandatory to indicate the performance data (accuracy and range) with favourable conditions and with unfavourable conditions.

Favourable conditions are white and diffuse reflecting target, low background illumination and temperatures about 20 °C.

Unfavourable conditions are targets with lower or higher reflectivity, high background illumination and temperatures at the upper or lower end of the specified temperature range.

For an example, see [Annex A](#).

6 Test procedure for determining the compliance with accuracy specifications

6.1 Test concept

As mentioned before, the accuracy of handheld laser distance meters depends on various factors. The test concept of this document focuses on the main influences, such as measurement distance, temperature of instrument and background illumination.

The target reflectivity, which also can have an impact on the accuracy, is not tested directly by changing targets with different reflectivity factors. The reason is that it is quite difficult to get targets with well defined, homogeneous and stable reflectivity factors. In addition, the effect of a target with a lower reflectivity factor of 25 % can be tested using a target with 100 % reflectivity at double distance. Therefore, the effects of lower reflectivity factors are indirectly tested at the absolute distance test described in [6.4.2](#).

6.2 Requirements

6.2.1 General

To determine compliance with the accuracy specifications for handheld laser distance meters, the following measurement setup is used.

For examples of determining compliance with accuracy specifications, see [Annex B](#).

6.2.2 Apparatus

6.2.2.1 Target plate, meeting the following specifications:

Size: 0,25 m × 0,25 m;

Reflectivity: (95 ± 5) % (see [Annex E](#)).

Special attention is to be paid to the effect of penetration of the laser beam into certain materials (see [Annex E](#)). In addition, specular surfaces and reflectors should be avoided along the measurement line.

6.2.2.2 Background illumination lamp, that shall achieve at least an illuminance of 30 klx on the used target plate. Check with an illuminance meter (lux meter) directed as perpendicularly as possible to the target at 0,1 m distance from the target.

6.2.2.3 Temperature chamber, capable of heating the devices under test up to +40 °C and cooling them down to +5 °C. The measurements can be taken inside a big temperature chamber or by taking the heated (or cooled) devices out of the chamber and immediately taking the measurements on a known reference distance.

6.2.2.4 Calibrated reference distance measurement system, to determine the distance between target and device under test. The uncertainty of measurement of the reference system shall be 20 % or less than the expected uncertainty of measurement of the device under test.

6.3 Configuration of check points

Select 10 check points CP01 to CP10.

Check point CP10 shall be set either to the longest specified distance of the device under test or to the maximum range of the reference distance measurement system, but at least 10 m. The following configuration of check points takes into consideration that typical customers measure shorter distances more frequently than longer ones.

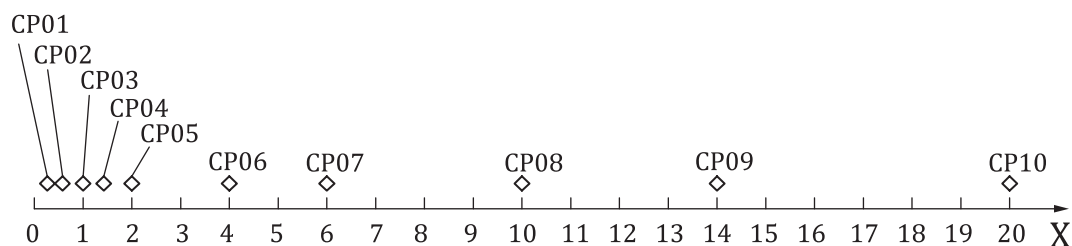

$$D(\text{CP01}) = 0,02 \cdot D(\text{CP10})$$

$$D(\text{CP02}) = 0,03 \cdot D(\text{CP10})$$

$$D(\text{CP03}) = 0,05 \cdot D(\text{CP10})$$

$$D(\text{CP04}) = 0,07 \cdot D(\text{CP10})$$

$$D(\text{CP05}) = 0,10 \cdot D(\text{CP10})$$

$$D(\text{CP06}) = 0,20 \cdot D(\text{CP10})$$

$$D(\text{CP07}) = 0,30 \cdot D(\text{CP10})$$

$$D(\text{CP08}) = 0,50 \cdot D(\text{CP10})$$

$$D(\text{CP09}) = 0,70 \cdot D(\text{CP10})$$

$$D(\text{CP10}) = \text{max distance}$$

X: Distance (m)

Figure 1 — Example: CP10 = 20 m

6.4 Measurement procedure

6.4.1 General

To determine compliance with accuracy specifications for handheld laser distance meters, the following procedure is recommended.

6.4.2 Absolute distance test

This test shall be performed under favourable conditions.

Target reflectivity: $(95 \pm 5) \%$;

Background illumination: $<3 \text{ klx}$;

Temperature range: $(20 \pm 5) \text{ }^\circ\text{C}$;

Define the check points (see [6.3](#)).

At each check point, determine the reference distance with the reference distance measurement system and take 10 measurements with the device under test. Ensure correct alignment of the handheld laser distance meter to the target by checking at the shortest and the longest distance of the reference system that the laser spot still hits the target at the centre mark and that the target is oriented perpendicularly to the laser beam within $\pm 1^\circ$. Due to this alignment procedure, an additional offset error might come into account which is not allowed to be compensated by a corrective value (for more details, refer to [Annex G](#)).

6.4.3 Background illumination test

This test evaluates the influence of high background illumination on the measurement result in comparison to the result of measurements at low background illumination.

Target reflectivity: $(95 \pm 5) \%$;

Background illumination, case A: < 3 klx;

Background illumination, case B: > 30 klx;

Temperature range: $(20 \pm 5) ^\circ\text{C}$.

Build up the measurement setup for the background illumination test (see [Annex D](#) for an example of a possible setup). At the checkpoint CP01, CP02 or CP03 (depending on which point fits better for the test under [6.4.4](#)), set the background illumination reflected by the measurement target to an illuminance less than 3 klx. Determine the reference distance with the reference distance measurement system and take and record 10 measurements with the device under test. In the next step, set the background illumination reflected by the measurement target to an illuminance higher than 30 klx and take and record another 10 measurements with the device under test.

6.4.4 Temperature test

This test evaluates the influence of other ambient temperatures on the measurement result in comparison to the measurement results at $20 ^\circ\text{C}$.

Target reflectivity: $(95 \pm 5) \%$;

Background illumination: < 3 klx;

Temperature, case A: $+5 ^\circ\text{C} \pm 2 ^\circ\text{C}$;

Temperature, case B: $+20 ^\circ\text{C} \pm 2 ^\circ\text{C}$;

Temperature, case C: $+40 ^\circ\text{C} \pm 2 ^\circ\text{C}$.

Put the device under test into a temperature chamber and let the instruments adapt to the test temperature of case A (recommendation: $2 \text{ min}/^\circ\text{C}$). Then, take the instrument out of the chamber and immediately take and record 10 measurements at the distance CP01, CP02 or CP03 (same distance as [6.4.3](#)). Check that the background illumination reflected by the target is below 3 klx. Repeat the same procedure for the remaining two test cases. At test case A, verify that the receiver optics do not mist up during measurements.

Alternatively, the measurements could be taken directly inside a temperature chamber if the instrument is mounted on a reference distance measuring bar. In this case, the expansion of the reference distance measuring bar over temperature has to be compensated in the calculations.

6.5 Calculation of deviations and uncertainty of measurement

6.5.1 Absolute distance test

Calculate the deviation ΔM_i of all measurements M_i from the corresponding reference value at each check point.

$$\Delta M_i = M_i - D_{\text{REF}} \quad (1)$$

Check, if all calculated deviations ΔM_i are inside the specified tolerance field defined for favourable conditions. Assuming a level of confidence of 95 %, only 5 of the 100 measured points (10 at each check point) are allowed to lie outside the tolerance field with favourable conditions.

At each check point, calculate the experimental mean value of the absolute distance test, \bar{D}_{AD} :

$$\bar{D}_{\text{AD}} = \frac{1}{N} \sum_{i=1}^N M_i \quad (2)$$

Calculate at each check point the deviation $\Delta \bar{D}_{\text{AD}}$ of the experimental mean value from the corresponding reference value:

$$\Delta \bar{D}_{\text{AD}} = \bar{D}_{\text{AD}} - D_{\text{REF}} \quad (3)$$

At each check point, calculate the corresponding experimental standard deviation, s_{AD} , of the measured values and take it as the standard uncertainty, u_{AD} , associated with the measured values:

$$u_{\text{AD}} = s_{\text{AD}} = \sqrt{\frac{1}{N-1} \sum_{i=1}^N (M_i - \bar{D}_{\text{AD}})^2} \quad (4)$$

6.5.2 Background illumination test

Calculate for both cases, low background illumination BG, low < 3 klx, and high background illumination BG, high > 30 klx, and for each measurement $M_{i,X}$, the deviation $\Delta M_{i,X}$ from the reference value.

For each background illumination case, calculate the experimental mean value, $\bar{D}_{\text{BG},X}$:

$$\bar{D}_{\text{BG},X} = \frac{1}{N} \sum_{i=1}^N M_{i,X} \quad (5)$$

where X = background low, high.

Calculate the deviation $\Delta \bar{D}_{\text{BG},X}$ of the experimental mean value from the corresponding reference value:

$$\Delta \bar{D}_{\text{BG},X} = \bar{D}_{\text{BG},X} - D_{\text{BG,REF}} \quad (6)$$

where X = background low, high.

Calculate the additional deviation $\Delta\bar{D}_{\text{BG,Add}}$ caused by the background illumination:

$$\Delta\bar{D}_{\text{BG,Add}} = \bar{D}_{\text{BG,high}} - D_{\text{BG,low}} \quad (7)$$

Calculate the corresponding experimental standard deviations for both cases of background illumination and take them as the standard uncertainties associated with both cases:

$$u_{\text{BG},X} = s_{\text{BG},X} = \sqrt{\frac{1}{N-1} \sum_{i=1}^N (M_{i,X} - \bar{D}_{\text{BG},X})^2} \quad (8)$$

where X = background low, high.

Calculate the additional uncertainty, $u_{\text{BG,Add}}$, caused by the background illumination, assuming that $u_{\text{BG,high}} > u_{\text{BG,low}}$. If $u_{\text{BG,high}} < u_{\text{BG,low}}$, then $u_{\text{BG,Add}} = 0$:

$$u_{\text{BG,Add}} = \sqrt{u_{\text{BG,high}}^2 - u_{\text{BG,low}}^2} \quad (9)$$

6.5.3 Temperature test

Calculate for each temperature case and for each measurement $M_{i,X}$, the deviation $\Delta M_{i,X}$ from the corresponding reference value.

For each temperature case, calculate the corresponding experimental mean value, $\bar{D}_{T,X}$:

$$\bar{D}_{T,X} = \frac{1}{N} \sum_{i=1}^N M_{i,X} \quad (10)$$

where X = +5 °C, +20 °C, +40 °C.

Calculate the deviation $\bar{D}_{T,X}$ of the experimental mean value from the corresponding reference value:

$$\Delta\bar{D}_{T,X} = \bar{D}_{T,X} - D_{T,\text{REF}} \quad (11)$$

where X = +5 °C, +20 °C, +40 °C.

Calculate the additional deviation $\Delta\bar{D}_{T05,\text{Add}}$ and $\Delta\bar{D}_{T40,\text{Add}}$ caused by the temperature influences at +5 °C and +40 °C in reference to the value calculated at 20 °C:

$$\Delta\bar{D}_{T05,\text{Add}} = \Delta\bar{D}_{T,5^\circ\text{C}} - \Delta\bar{D}_{T,20^\circ\text{C}} \quad (12)$$

$$\Delta\bar{D}_{T40,\text{Add}} = \Delta\bar{D}_{T,40^\circ\text{C}} - \Delta\bar{D}_{T,20^\circ\text{C}} \quad (13)$$

Calculate the corresponding experimental standard deviations for each temperature case and take them as the standard uncertainties associated to the three cases:

$$u_{T,X} = s_{T,X} = \sqrt{\frac{1}{N-1} \sum_{i=1}^N (M_{i,X} - \bar{D}_{T,X})^2} \quad (14)$$

where X = +5 °C, +20 °C, +40 °C.

Calculate the additional uncertainties $u_{T,Add}$ caused by the temperature influences in reference to the value calculated at 20 °C. For calculation, select the bigger value of the two possible values $u_{T,05\text{ °C}}$ and $u_{T,40\text{ °C}}$. If $u_{T,20\text{ °C}}$ is the biggest of the three uncertainties, then $u_{T,Add} = 0$:

$$u_{T,Add} = \sqrt{u_{T,X}^2 - u_{T,20\text{ °C}}^2} \quad (15)$$

where $X = 5\text{ °C}$ or 40 °C .

6.5.4 Combined deviation and combined uncertainty of measurements

Calculate the combined deviation range $\Delta\bar{D}_{C,min} \dots \Delta\bar{D}_{C,max}$ of the experimental mean value (depending on temperature and background illumination) using [Formulae \(16\)](#) and [\(17\)](#):

$$\Delta\bar{D}_{C,max} = \Delta\bar{D}_{AD} + \max(\Delta\bar{D}_{BG,Add}, 0) + \max(\Delta\bar{D}_{T05,Add}, \Delta\bar{D}_{T40,Add}, 0) \quad (16)$$

$$\Delta\bar{D}_{C,min} = \Delta\bar{D}_{AD} + \min(\Delta\bar{D}_{BG,Add}, 0) + \min(\Delta\bar{D}_{T05,Add}, \Delta\bar{D}_{T40,Add}, 0) \quad (17)$$

NOTE 1 For $\Delta\bar{D}_{C,max}$, only positive contributions of $\Delta\bar{D}_{BG,Add}$ and only the maximum positive contribution of $\Delta\bar{D}_{T05,Add}$ or $\Delta\bar{D}_{T40,Add}$ are taken into account.

NOTE 2 For $\Delta\bar{D}_{C,min}$, only negative contributions of $\Delta\bar{D}_{BG,Add}$ and only the most negative contribution of $\Delta\bar{D}_{T05,Add}$ or $\Delta\bar{D}_{T40,Add}$ are taken into account.

Calculate the uncertainty, u_{MR} , caused by the measurement resolution of the display of the device under test:

$$u_{RM} = \frac{R_M}{2\sqrt{3}} \quad (18)$$

where R_M is the measurement resolution.

Calculate the combined uncertainty, u_C , of the measured values:

$$u_C = \sqrt{u_{REF,AD}^2 + u_{REF,BG}^2 + u_{REF,T}^2 + u_{RM}^2 + u_{AD}^2 + u_{BG,Add}^2 + u_{T,Add}^2} \quad (19)$$

where

$u_{REF,AD}$ is the standard uncertainty of the reference system at the absolute distance test;

$u_{REF,BG}$ is the standard uncertainty of the reference system at the background illumination test;

$u_{REF,T}$ is the standard uncertainty of the reference system at the temperature test;

u_{RM} is the standard uncertainty due to the measurement resolution;

- u_{AD} is the standard uncertainty of measurements at the absolute distance test of the check point that was used for the background illumination test and the temperature test;
- $u_{BG,Add}$ is the additional standard uncertainty of measurement at the high background illumination case in relation to the standard uncertainty of measurement at the low background illumination case;
- $u_{T,Add}$ is the additional standard uncertainty of measurement at higher or lower temperature in relation to the standard uncertainty of measurement at 20 °C.

6.5.5 Expanded uncertainty of measurements

Calculate the expanded uncertainty, U , for a level of confidence of 95 %:

$$U = k \cdot u_C \tag{20}$$

where $k = 2$.

6.5.6 Statement of test result

Give a statement on the test result as follows.

Deviation range of average values: $\Delta\bar{D}_{C,min} \dots \Delta\bar{D}_{C,max} = \text{--- mm} \dots \text{--- mm}$

Expanded uncertainty of a single measurement:
(level of confidence 95 %, $k = 2,0$) $U = \text{--- mm}$

Result: within/out of specification

NOTE Out of specification is given if $\Delta\bar{D}_{C,min} - U <$ negative accuracy limit with unfavourable conditions or if $\Delta\bar{D}_{C,max} + U >$ positive accuracy limit with unfavourable conditions specified by the manual.

7 Test procedure for determining compliance with range specifications

7.1 Test concept

Handheld laser distance meters are often specified up to ranges extending the practical dimensions of typical mechanical test benches of reference measurement systems in laboratories. In this case, the length of the bench determines the maximum distance investigated for the accuracy compliance test (see 6.3). In this clause, a test procedure is presented to determine compliance with range specifications for this scenario. Similar to the test procedure for determining the compliance with accuracy specifications, the compliance with range specifications is also tested with favourable conditions and with unfavourable conditions. In case of unfavourable conditions, background illumination has the biggest influence by far. Therefore, the test procedure focuses on this effect.

7.2 Requirements

To test compliance with the range specifications for handheld laser distance meters, the following measurement setup is recommended.

For examples of determining compliance with range specifications, see [Annex C](#).

Target plate:	Size: at least 0,5 m × 0,5 m, recommended 1,0 m × 1,0 m. Reflectivity: (95 ± 5) % (a lower target reflectivity causes lower receiver signals, but also lower noise from background illumination). Orientation: perpendicular to the measurement direction (±1 °).
Background:	Background illumination of <3 klx with favourable conditions and at least 30 klx with unfavourable conditions. (Check with a lux meter directed perpendicularly to the centre of the target plate at 0,1 m distance from the target plate).
Reference:	To determine the distance between the target and the device under test, a calibrated reference distance measurement system shall be used. The uncertainty of measurement of the reference system shall be 20 % or less than the expected uncertainty of measurement of the device under test. For reference measurements, it might be necessary to shadow the target plate or to use a target prism.

7.3 Description of measurement procedure

To test the compliance with the specified range for a handheld laser distance meter, the following measurement procedure is recommended.

- Step 1: Build up the measurement setup to test at the specified maximum range with favourable conditions (CP11). Verify, that the target reflectivity is diffuse and about (95 ± 5) % (refer to [Annex E](#)) and that the background illumination is <3 klx.
- Step 2: Determine the distance between the device under test and the target plate using a suitable and calibrated reference system.
- Step 3: Start 10 measurements and record the results.
- Step 4: Change the measurement setup to repeat the test at the specified maximum range with unfavourable conditions (CP12). The target reflectivity shall have (95 ± 5) %. Verify that the background illumination is at least 30 klx. Repeat steps 2 and 3.

NOTE If the instrument performs less than eight of ten released measurements, at each test case, the range specification is not fulfilled.

7.4 Calculation of deviation and uncertainty of measurement

From the measurements taken at the range tests, calculate for each test case the experimental mean value \bar{D}_{RT} and the deviation $\Delta\bar{D}_{RT}$ [see [Formula \(2\)](#)] of the average value from the reference value D_{REF} :

$$\Delta\bar{D}_{RT} = \bar{D}_{RT} - D_{REF} \quad (21)$$

Consider the uncertainty u_{REF} of the reference system stated on the corresponding calibration certificate and include to this all additional uncertainties from the test setup (see [Table 3](#), note b).

Calculate the uncertainty u_{RM} caused by the measurement resolution of the device under test [see [Formula \(18\)](#)]. Be aware that handheld laser distance meters typically change automatically the measurement resolution when measuring large distances.

Calculate for each test case the experimental standard deviation s_{RT} of the measurements taken at the range test and take it as the standard uncertainty u_{RT} associated with the measured values [refer to [Formula \(4\)](#)].

Calculate for each test case the combined uncertainty $u_{C,RT}$ of the measurements taken at the range test with [Formula \(22\)](#):

$$u_{C,RT} = \sqrt{u_{REF}^2 + u_{RM}^2 + u_{RT}^2} \tag{22}$$

Calculate for each test case the expanded uncertainty U_{RT} for a level of confidence of 95 %:

$$U_{RT} = k \cdot u_{C,RT} \tag{23}$$

where $k = 2$.

7.5 Statement of test result

Give a statement as follows.

Result of range test at CP11 with favourable conditions.

Deviation of average value: $\Delta\bar{D}_{RT} = \text{--- mm}$

Expanded uncertainty of a single measurement:
(level of confidence 95 %, $k = 2,0$) $U_{RT} = \text{--- mm}$

Test result: within/out of specification

NOTE Out of specification at CP11 is given if $\Delta\bar{D}_{RT} - U_{RT} <$ specified negative tolerance with favourable conditions, or if $\Delta\bar{D}_{RT} + U_{RT} >$ specified positive tolerance with favourable conditions, or if less than 80 % of the started measurements could be performed.

Result of range test at CP12 with unfavourable conditions.

Deviation of average value: $\Delta\bar{D}_{RT} = \text{--- mm}$

Expanded uncertainty of a single measurement:
(level of confidence 95 %, $k = 2,0$) $U_{RT} = \text{--- mm}$

Test result: within/out of specification

NOTE Out of specification at CP12 is given if $\Delta\bar{D}_{RT} - U_{RT} <$ specified negative tolerance with unfavourable conditions, or if $\Delta\bar{D}_{RT} + U_{RT} >$ specified positive tolerance with unfavourable conditions, or if less than 80 % of the started measurements could be performed.

Annex A (informative)

Example of performance specification

Instrument with accuracy specification of 1,5 mm and 100 m maximum range.

Table A.1 — Accuracy specifications

Accuracy with favourable conditions ^a :	±1,5 mm (95 % level of confidence) from 30 m additional tolerance of 0,1 mm/m
Accuracy with unfavourable conditions ^b :	±3,0 mm (95 % level of confidence) from 30 m additional tolerance of 0,20 mm/m
^a White diffuse reflecting target (95 ± 5) %, low background illumination <3 klx, temperatures about 20 °C. ^b 10 % to 100 % diffuse target reflectivity, high background illumination of approximately 30 klx, temperatures from -10 °C to +50 °C.	

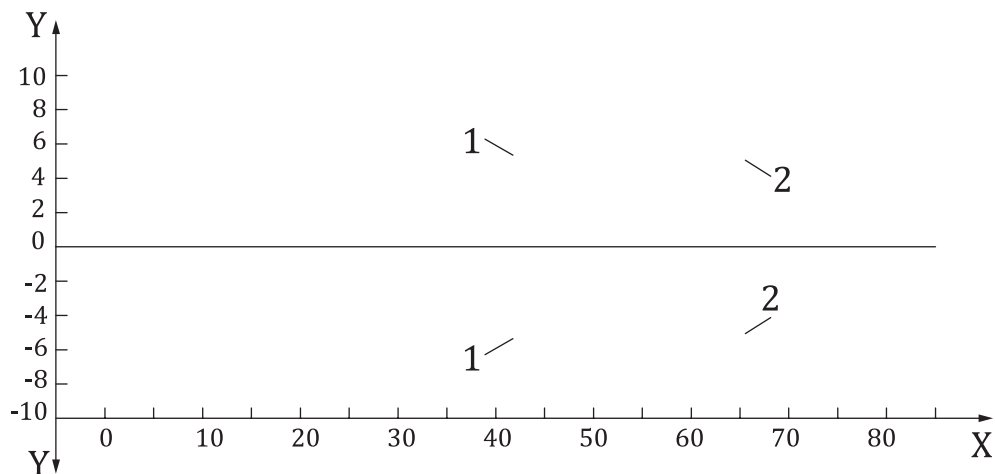

Key

- X distance (m)
- Y accuracy specification (mm)
- 1 accuracy specification at unfavourable conditions
- 2 accuracy specification at favourable conditions

Figure A.1 — Example of accuracy specifications over distance

Table A.2 — Range specifications

Range with favourable conditions ^a :	0,1 m to 100 m
Range with unfavourable conditions ^b :	0,1 m to 50 m
^a White diffuse reflecting target (95 ± 5) %, low background illumination <3 klx, temperatures about 20 °C. ^b 10 % to 100 % diffuse target reflectivity, high background illumination of approximately 30 klx, temperatures from -10 °C to +50 °C.	

Annex B (informative)

Examples of determining compliance with accuracy specifications

B.1 Example 1

B.1.1 Performance specifications

Table B.1 — Performance specifications

Accuracy specification:	±1,5 mm (95 % level of confidence) with favourable conditions ^a from 15 m additional tolerance of 0,10 mm/m
	±2,0 mm (95 % level of confidence) with unfavourable conditions ^b from 15 m additional tolerance of 0,15 mm/m
Range specification:	0,05 m to 60 m with favourable conditions ^a
	0,05 m to 40 m with unfavourable conditions ^b
^a White diffuse reflecting target, low background illumination <3 klx, temperatures about 20 °C. ^b 10 % to 100 % diffuse target reflectivity, high background illumination of approximately 30 klx, temperatures from -10 °C to 50 °C.	

B.1.2 Absolute distance test

Table B.2 — Determination of check points

Range of instrument:	0,00 m to 60 m
Range of reference system:	0,00 m to 30 m
Check points:	CP01 = 0,60 m CP02 = 0,90 m CP03 = 1,50 m CP04 = 2,10 m CP05 = 3,00 m CP06 = 6,00 m CP07 = 9,00 m CP08 = 15,00 m CP09 = 21,00 m CP10 = 30,00 m

Table B.3 — Absolute distance test

Dimensions in millimetres

CP	01	02	03	04	05	06	07	08	09	10
D_{REF}	600,05	900,04	1 500,02	2 100,03	3 000,01	5 999,95	9 000,03	15 000,07	21 000,03	30 000,08
M 1	600,3	900,2	1 500,8	2 100,2	2 999,7	5 999,8	8 999,7	14 999,8	21 000,1	30 000,5
M 2	600,5	900,4	1 500,4	2 099,9	2 999,9	5 999,2	8 999,4	15 000,4	21 001,0	29 999,7
M 3	600,1	899,8	1 500,2	2 100,0	3 000,1	6 000,2	8 999,8	15 000,2	21 000,5	30 000,6
M 4	599,9	899,7	1 500,4	2 100,4	3 000,6	5 999,5	9 000,1	15 000,1	20 999,8	30 001,3
M 5	599,7	900,7	1 499,7	2 100,5	2 999,8	6 000,5	9 000,2	15 000,9	21 000,7	30 000,4
M 6	599,6	900,3	1 500,5	2 100,2	2 999,4	5 999,8	8 999,7	14 999,4	20 999,4	29 999,3
M 7	599,8	900,0	1 500,2	2 099,5	2 999,9	6 000,0	9 000,3	15 000,5	21 000,5	30 000,9

Table B.3 (continued)

CP	01	02	03	04	05	06	07	08	09	10
M 8	599,4	899,9	1 499,8	2 100,2	3 000,3	5 999,7	9 000,5	15 000,1	21 000,1	30 001,8
M 9	600,0	900,5	1 500,0	2 100,4	2 999,7	5 999,8	9 000,0	14 999,9	21 001,1	30 000,1
M 10	599,9	899,8	1 500,2	2 100,7	3 000,3	5 999,5	8 999,2	14 999,8	20 999,7	30 000,7
$\Delta M 1$	0,25	0,16	0,78	0,17	-0,31	-0,15	-0,33	-0,27	0,07	0,42
$\Delta M 2$	0,45	0,36	0,38	-0,13	-0,11	-0,75	-0,63	0,33	0,97	-0,38
$\Delta M 3$	0,05	-0,24	0,18	-0,03	0,09	0,25	-0,23	0,13	0,47	0,52
$\Delta M 4$	-0,15	-0,34	0,38	0,37	0,59	-0,45	0,07	0,03	-0,23	1,22
$\Delta M 5$	-0,35	0,66	-0,32	0,47	-0,21	0,55	0,17	0,83	0,67	0,32
$\Delta M 6$	-0,45	0,26	0,48	0,17	-0,61	-0,15	-0,33	-0,67	-0,63	-0,78
$\Delta M 7$	-0,25	-0,04	0,18	-0,53	-0,11	0,05	0,27	0,43	0,47	0,82
$\Delta M 8$	-0,65	-0,14	-0,22	0,17	0,29	-0,25	0,47	0,03	0,07	1,72
$\Delta M 9$	-0,05	0,46	-0,02	0,37	-0,31	-0,15	-0,03	-0,17	1,07	0,02
$\Delta M 10$	-0,15	-0,24	0,18	0,67	0,29	-0,45	-0,83	-0,27	-0,33	0,62
\bar{D}_{AD}	599,92	900,13	1 500,22	2 100,20	2 999,97	5 999,80	8 999,89	15 000,11	21 000,29	30 000,53
$\Delta \bar{D}_{AD}$	-0,13	0,09	0,20	0,17	-0,04	-0,15	-0,14	0,04	0,26	0,45
u_{AD}	0,33	0,34	0,33	0,34	0,36	0,37	0,41	0,42	0,56	0,73

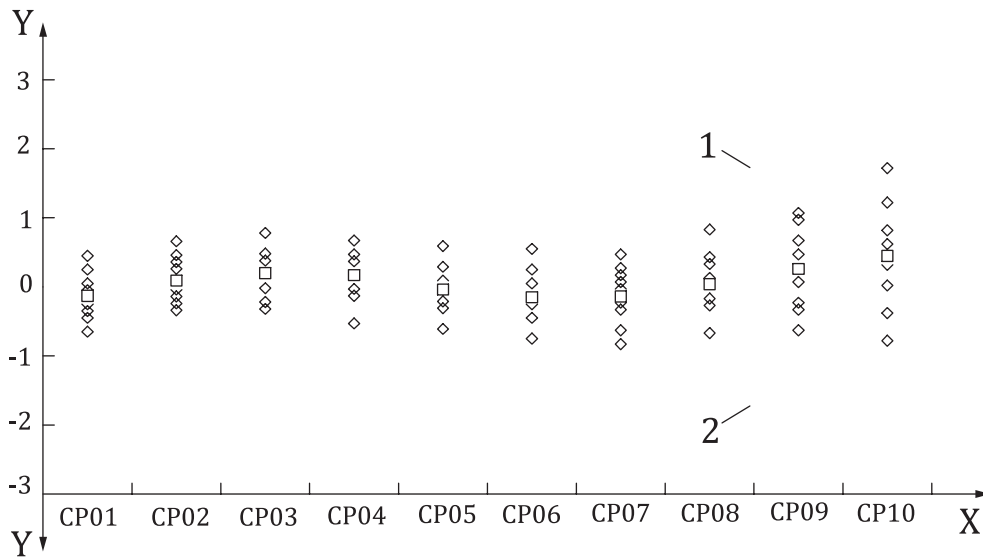

Key

- X check point
- Y deviation from reference (mm)
- 1 positive tolerance limit
- 2 negative tolerance limit
- ◇ $\Delta M_{i,X}$
- $\Delta \bar{D}_{AD,X}$

Figure B.1 — Absolute distance deviations with favourable conditions

B.1.3 Background illumination test (CP01)

Table B.4 — Conditions for background illumination test

Target	0,25 m × 0,25 m with (95 ± 5) % reflectivity
Illumination	low (<3 klx) and high (30 klx)
Temperature	20 °C

Table B.5 — Background illumination test at CP01

Dimensions in millimetres

Condition	BG low	BG high
D_{REF}	600,05	600,05
M 01	600,3	600,8
M 02	600,2	600,5
M 03	599,7	599,8
M 04	600,3	600,3
M 05	599,8	599,9
M 06	600,4	600,1
M 07	600,1	600,5
M 08	599,9	600,3
M 09	600,5	601,0
M 10	600,0	600,1
$\Delta M 1$	0,25	0,75
$\Delta M 2$	0,15	0,45
$\Delta M 3$	-0,35	-0,25
$\Delta M 4$	0,25	0,25
$\Delta M 5$	-0,25	-0,15
$\Delta M 6$	0,35	0,05
$\Delta M 7$	0,05	0,45
$\Delta M 8$	-0,15	0,25
$\Delta M 9$	0,45	0,95
$\Delta M 10$	-0,05	0,05
$\bar{D}_{BG,X}$	600,12	600,33
$\Delta \bar{D}_{BG,X}$	0,07	0,28
$\Delta \bar{D}_{BG,Add}$	—	0,21
$u_{BG,X}$	0,27	0,38
$u_{BG,Add}$	—	0,27

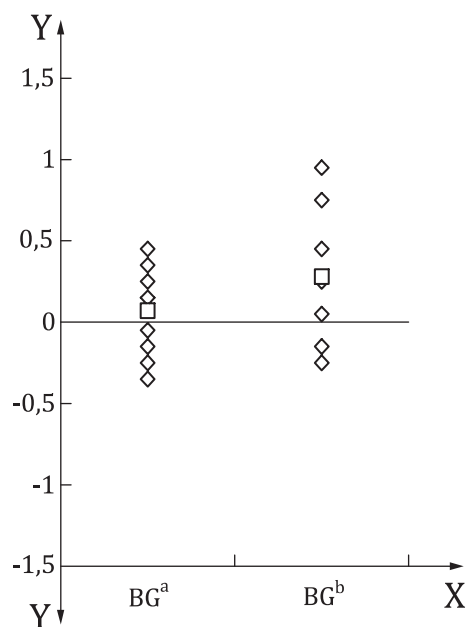

Key

- X measurement condition
- Y deviation from reference (mm)
- ◇ $\Delta M_{i,X}$
- $\Delta \bar{D}_{BG,X}$
- a Low.
- b High.

Figure B.2 — Background illumination test

B.1.4 Temperature test (CP01)

Table B.6 — Conditions for temperature test

Target:	0,25 m × 0,25 m with (95 ± 5) % reflectivity
Illumination:	low (<3 klx)
Temperature:	5 °C, 20 °C, 40 °C

Table B.7 — Temperature test at CP01

Dimensions in millimetres

Condition	5 °C	20 °C	40 °C
D_{REF}	601,40	601,45	601,50
M 01	601,3	601,8	602,2
M 02	601,2	601,2	601,4
M 03	601,1	601,7	601,3
M 04	601,5	601,4	601,6
M 05	601,0	601,6	602,0
M 06	601,2	601,3	601,5
M 07	601,1	601,7	601,9
M 08	600,9	602,0	601,7
M 09	601,4	601,4	601,8

Table B.7 (continued)

Condition	5 °C	20 °C	40 °C
M 10	601,2	601,5	601,5
ΔM 1	-0,10	0,35	0,70
ΔM 2	-0,20	-0,25	-0,10
ΔM 3	-0,30	0,25	-0,20
ΔM 4	0,10	-0,05	0,10
ΔM 5	-0,40	0,15	0,50
ΔM 6	-0,20	-0,15	0,00
ΔM 7	-0,30	0,25	0,40
ΔM 8	-0,50	0,55	0,20
ΔM 9	0,00	-0,05	0,30
ΔM 10	-0,20	0,05	0,00
$\bar{D}_{T,X}$	601,19	601,56	601,69
$\Delta \bar{D}_{T,X}$	-0,21	0,11	0,19
$\Delta \bar{D}_{T,X,Add}$	-0,32	—	0,08
$u_{T,X}$	0,18	0,25	0,28
$u_{T,Add}$	—	—	0,14

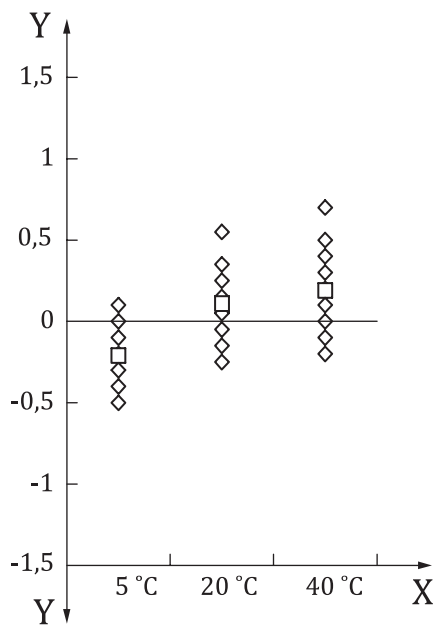

Key

- X measurement condition
- Y deviation from reference (mm)
- ◇ $\Delta M_{i,X}$
- $\Delta \bar{D}_{T,X}$

Figure B.3 — Temperature test

Table B.8 — Combined deviation and expanded uncertainty

Dimensions in millimetres

Calculations at CP1	Value
$\Delta \bar{D}_{AD}$	-0,13
$\Delta \bar{D}_{BG,Add}$	0,21
$\Delta \bar{D}_{T05,Add}$	-0,32
$\Delta \bar{D}_{T40,Add}$	0,08
$\Delta \bar{D}_{C,max}$	+0,16
$\Delta \bar{D}_{C,min}$	-0,45
$u_{REF,AD}$	0,10
$u_{REF,BG}$	0,10
$u_{REF,T}$	0,10
u_{MR} (MR = 0,1 mm)	0,03
u_{AD}	0,33
$u_{BG,Add}$	0,27
$u_{T,Add}$	0,14
u_C	0,48
U (95 % level of confidence, $k = 2$)	0,96
$\Delta \bar{D}_{C,max} + U$	1,12
$\Delta \bar{D}_{C,min} + U$	-1,41
Positive tolerance with unfavourable conditions	+2,00
Negative tolerance with unfavourable conditions	-2,00

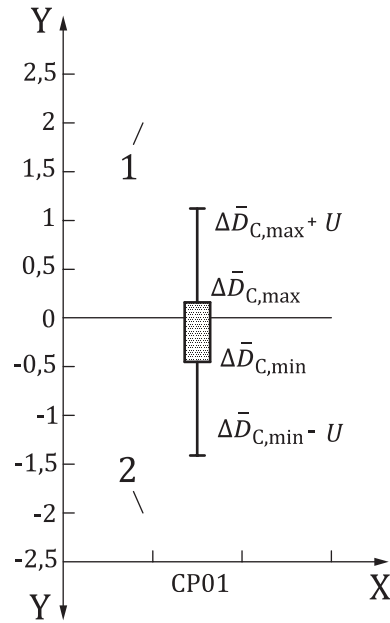

- Key**
- X check point
 - Y deviation (mm)
 - 1 positive tolerance limit
 - 2 negative tolerance limit

Figure B.4 — Combined deviation range ± expanded uncertainty

Table B.9 — Test result at check point CP01

Deviation range of average value:	$\Delta\bar{D}_{C,min} \dots \Delta\bar{D}_{C,max} = -0,45 \text{ mm} \dots +0,16 \text{ mm}$
Expanded uncertainty of single measurements: (level of confidence 95 %, $k = 2,0$)	$U = 0,96 \text{ mm}$
Test result:	within specification

B.2 Example 2

B.2.1 Performance specifications

Table B.10 — Performance specifications

Accuracy specification:	±1,0 mm (95 % level of confidence) with favourable conditions ^a from 10 m additional tolerance of 0,10 mm/m
	±1,5 mm (95 % level of confidence) with unfavourable conditions ^b from 10 m additional tolerance of 0,15 mm/m
Range specification:	0,10 m to 50 m with favourable conditions ^a
	0,10 m to 30 m with unfavourable conditions ^b
^a White diffuse reflecting target, low background illumination <3 klx, temperatures about 20 °C.	
^b 10 % to 100 % diffuse target reflectivity, high background illumination of approximately 30 klx, temperatures from -10 °C to +50 °C.	

B.2.2 Absolute distance test

Table B.11 — Determination of check points

Range of instrument:	0,00 m to 50 m
Range of reference system:	0,00 m to 20 m
Check points:	CP01 = 0,40 m CP02 = 0,60 m CP03 = 1,00 m CP04 = 1,40 m CP05 = 2,00 m CP06 = 4,00 m CP07 = 6,00 m CP08 = 10,00 m CP09 = 14,00 m CP10 = 20,00 m

Table B.12 — Absolute distance test

Dimensions in millimetres

CP	01	02	03	04	05	06	07	08	09	10
D_{REF}	400,03	600,04	1 000,02	1 400,03	2 000,04	3 999,95	6 000,03	10 000,07	14 000,03	20 000,08
M 1	400,2	600,4	1 000,5	1 400,4	2 000,2	4 000,3	6 000,4	10 000,1	14 000,4	20 000,0
M 2	400,4	600,8	1 000,1	1 400,1	2 000,4	4 000,1	6 000,1	10 000,8	14 001,2	20 001,1
M 3	399,9	600,0	1 000,3	1 400,7	1 999,6	4 000,8	6 000,7	10 000,5	14 000,6	20 000,5
M 4	399,6	599,8	999,8	1 400,0	2 000,5	4 000,2	5 999,5	9999,3	13 999,2	20 001,6
M 5	400,2	600,5	1 000,4	1 400,5	2 000,0	3 999,8	6 000,6	10 000,2	14 000,1	20 000,3
M 6	400,5	600,1	1 000,8	1 399,7	2 000,7	4 000,4	5 999,8	10 000,0	14 000,0	20 000,7
M 7	399,9	600,6	999,9	1 400,2	2 000,3	3 999,3	6 000,9	10 000,3	14 000,8	19 999,1
M 8	399,4	600,2	999,6	1 399,8	2 001,0	4 000,5	5 999,9	9 999,5	13 999,5	20 000,8
M 9	399,8	599,7	1 000,1	1 400,0	2 000,1	4 000,0	6 000,5	9 999,8	14 000,9	20 000,2
M 10	400,3	600,3	1 000,3	1 400,9	1 999,8	3 999,7	6 000,1	9 999,6	13 999,7	19 999,6
$\Delta M 1$	0,17	0,36	0,48	0,37	0,16	0,35	0,37	0,03	0,37	-0,08
$\Delta M 2$	0,37	0,76	0,08	0,07	0,36	0,15	0,07	0,73	1,17	1,02
$\Delta M 3$	-0,13	-0,04	0,28	0,67	-0,44	0,85	0,67	0,43	0,57	0,42
$\Delta M 4$	-0,43	-0,24	-0,22	-0,03	0,46	0,25	-0,53	-0,77	-0,83	1,52
$\Delta M 5$	0,17	0,46	0,38	0,47	-0,04	-0,15	0,57	0,13	0,07	0,22
$\Delta M 6$	0,47	0,06	0,78	-0,33	0,66	0,45	-0,23	-0,07	-0,03	0,62
$\Delta M 7$	-0,13	0,56	-0,12	0,17	0,26	-0,65	0,87	0,23	0,77	-0,98
$\Delta M 8$	-0,63	0,16	-0,42	-0,23	0,96	0,55	-0,13	-0,57	-0,53	0,72
$\Delta M 9$	-0,23	-0,34	0,08	-0,03	0,06	0,05	0,47	-0,27	0,87	0,12
$\Delta M 10$	0,27	0,26	0,28	0,87	-0,24	-0,25	0,07	-0,47	-0,33	-0,48
\bar{D}_{AD}	400,02	600,24	1 000,18	1 400,23	2 000,26	4 000,11	6 000,25	10 000,01	14 000,24	20 000,39
$\Delta \bar{D}_{AD}$	-0,01	0,20	0,16	0,20	0,22	0,16	0,22	-0,06	0,21	0,31
u_{AD}	0,36	0,35	0,36	0,39	0,42	0,43	0,44	0,47	0,65	0,72

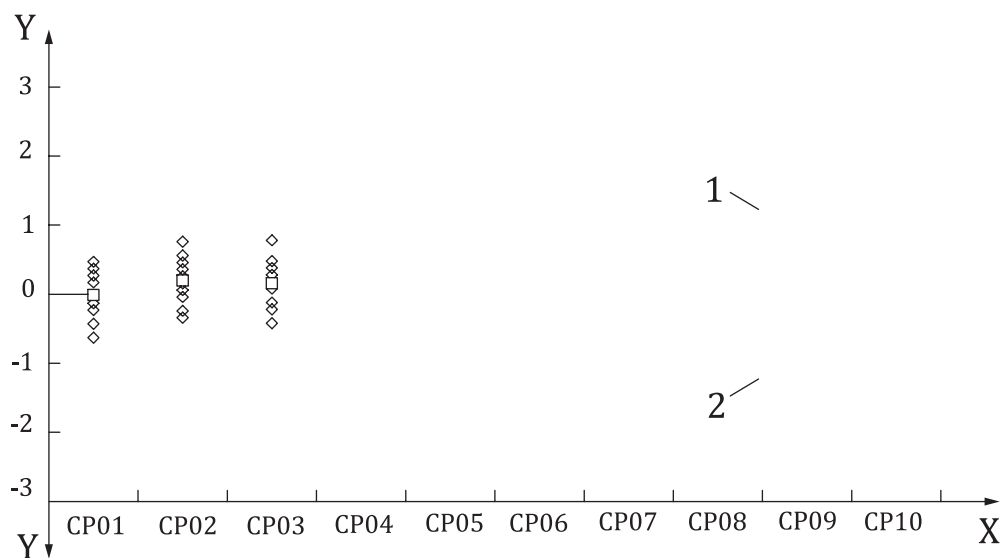

Key

- X check point
- Y deviation from reference (mm)
- 1 positive tolerance limit
- 2 negative tolerance limit

Figure B.5 — Absolute distance deviations measured with favourable conditions

B.2.3 Background illumination test (CP02)

Table B.13 — Conditions for background illumination test

Target:	0,25 m × 0,25 m with 100 % reflectivity
Illumination:	low (<3 klx) and high (>30 klx)
Temperature:	20 °C

Table B.14 — Background illumination test at CP02

Dimensions in millimetres

Condition	BG low	BG high
D_{REF}	600,04	600,04
M 01	600,6	601,4
M 02	600,5	601,6
M 03	599,9	600,0
M 04	600,0	600,6
M 05	600,7	599,5
M 06	600,3	600,9
M 07	599,9	601,6
M 08	599,7	599,6
M 09	600,4	601,0
M 10	599,9	600,3
ΔM 1	0,56	1,36

Table B.14 (continued)

Condition	BG low	BG high
$\Delta M 2$	0,46	1,56
$\Delta M 3$	-0,14	-0,04
$\Delta M 4$	-0,04	0,56
$\Delta M 5$	0,66	-0,54
$\Delta M 6$	0,26	0,86
$\Delta M 7$	-0,14	1,56
$\Delta M 8$	-0,34	-0,44
$\Delta M 9$	0,36	0,96
$\Delta M 10$	-0,14	0,26
$\bar{D}_{BG,X}$	600,19	600,65
$\Delta \bar{D}_{BG,X}$	0,15	0,61
$\Delta \bar{D}_{BG,Add}$	—	0,46
$u_{BG,X}$	0,35	0,78
$u_{BG,Add}$	—	0,70

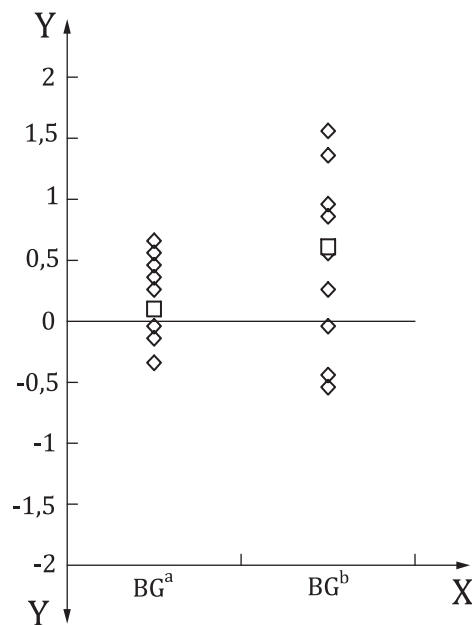

Key

- X measurement condition
- Y deviation from reference (mm)
- ◇ $\Delta M_{i,X}$
- $\Delta \bar{D}_{BG,X}$
- a Low.
- b High.

Figure B.6 — Background illumination test

B.2.4 Temperature Test (CP02)

Table B.15 — Conditions for temperature test

Target:	0,25 m × 0,25 m with 100 % reflectivity
Illumination:	low (<3 klx)
Temperature:	5 °C, 20 °C, 40 °C

Table B.16 — Temperature test at CP02

Dimensions in millimetres

Condition	5 °C	20 °C	40 °C
D_{REF}	600,02	600,04	600,07
M 01	600,5	600,4	600,2
M 02	600,8	600,8	599,9
M 03	600,3	600,0	599,5
M 04	600,1	600,1	600,5
M 05	600,7	600,5	599,7
M 06	600,0	600,3	600,0
M 07	600,6	599,9	599,4
M 08	600,9	600,4	599,8
M 09	600,4	600,6	599,6
M 10	600,2	599,7	599,1
$\Delta M 1$	0,48	0,36	0,13
$\Delta M 2$	0,78	0,76	-0,17
$\Delta M 3$	0,28	-0,04	-0,57
$\Delta M 4$	0,08	0,06	0,43
$\Delta M 5$	0,68	0,46	-0,37
$\Delta M 6$	-0,02	0,26	-0,07
$\Delta M 7$	0,58	-0,14	-0,67
$\Delta M 8$	0,88	0,36	-0,27
$\Delta M 9$	0,38	0,56	-0,47
$\Delta M 10$	0,18	-0,34	-0,97
$\bar{D}_{T,X}$	600,45	600,27	599,77
$\Delta \bar{D}_{T,X}$	0,43	0,23	-0,30
$\Delta \bar{D}_{T,Add}$	0,20	—	-0,53
$u_{T,X}$	0,30	0,34	0,41
$u_{T,Add}$	—	—	0,22

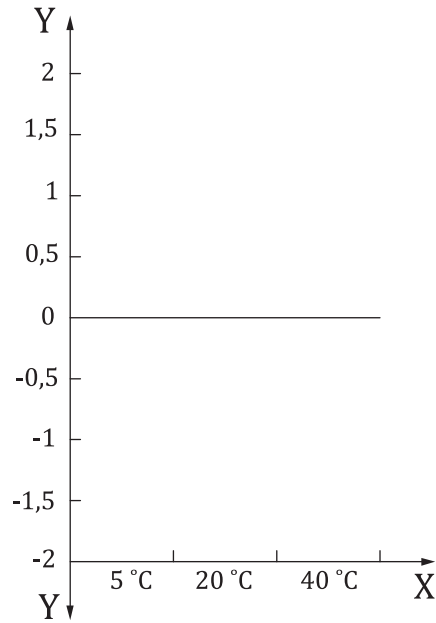
**Key**

- X measurement condition
 Y deviation from reference (mm)
 ◇ $\Delta M_{i,X}$
 □ $\Delta \bar{D}_{T,X}$

Figure B.7 — Temperature test**Table B.17 — Combined deviation and expanded uncertainty**

Dimensions in millimetres

Calculations at CP02	Value
$\Delta \bar{D}_{AD}$	0,20
$\Delta \bar{D}_{BG,Add}$	0,46
$\Delta \bar{D}_{T05,Add}$	0,20
$\Delta \bar{D}_{T40,Add}$	-0,53
$\Delta \bar{D}_{C,max}$	0,86
$\Delta \bar{D}_{C,min}$	-0,33
$u_{REF,AD}$	0,05
$u_{REF,BG}$	0,10
$u_{REF,T}$	0,10
$u_{RM} (R_M = 0,1 \text{ mm})$	0,03
u_{AD}	0,35
$u_{BG,Add}$	0,70
$u_{T,Add}$	0,22
u_C	0,83

Table B.17 (continued)

Calculations at CP02	Value
U (95 % level of confidence, $k = 2$)	1,66
$\Delta\bar{D}_{C,\max} + U$	2,52
$\Delta\bar{D}_{C,\min} - U$	-1,99
Positive tolerance with unfavourable conditions	1,50
Negative tolerance with unfavourable conditions	-1,50

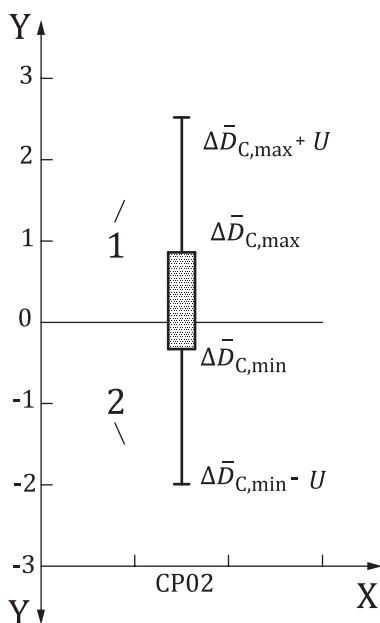

Key

- X check point
- Y deviation (mm)
- 1 positive tolerance limit
- 2 negative tolerance limit

Figure B.8 — Combined deviation range ± expanded uncertainty

Table B.18 — Test result at check point CP02

Deviation range of average values:	$\Delta\bar{D}_{C,\min} \dots \Delta\bar{D}_{C,\max} = -0,33 \text{ mm} \dots +0,86 \text{ mm}$
Expanded uncertainty of single measurements: (level of confidence 95 %, $k = 2,0$)	$U = 1,66 \text{ mm}$
Result:	out of specification

Annex C (informative)

Examples of determination of compliance with range specifications

C.1 Example 3

Table C.1 — Performance specifications

Specification of range and accuracy with favourable conditions ^a :	Range	0,1 m to 100 m
	Accuracy	±1,5 mm, from 30 m additional 0,05 mm/m (±5 mm at 100 m)
Specification of range and accuracy with unfavourable conditions ^b	Range	0,1 m to 50 m
	Accuracy	±3 mm, from 30 m additional 0,1 mm/m (±5 mm at 50 m)
^a White diffuse reflecting target, low background illumination, temperatures about 20 °C. ^b 10 % to 100 % diffuse target reflectivity, high background illumination, temperatures from -10 °C to +50 °C.		

Table C.2 — Range test measurements

Measurement	CP11	CP12	Unit
Condition	BG low	BG high	
\bar{D}_{REF}	100,453 0	50,001 5	m
M 01	100,452	50,005	m
M 02	100,454	50,001	m
M 03	100,453	50,000	m
M 04	100,452	50,002	m
M 05	100,455	50,003	m
M 06	100,451	50,004	m
M 07	100,454	50,001	m
M 08	100,456	50,002	m
M 09	100,454	50,003	m
M 10	100,453	50,000	m

Table C.3 — Range test calculations

Calculation	CP11	CP12	Unit
\bar{D}_{RT}	100,453 4	50,002 1	m
$\Delta\bar{D}_{RT}$	0,4	0,6	mm
u_{REF}	0,50	0,50	mm
u_{RM} ($R_M=1,0$ mm)	0,29	0,29	mm
u_{RT}	1,51	1,66	mm
$u_{C,RT}$	1,61	1,76	mm

Table C.3 (continued)

Calculation	CP11	CP12	Unit
U_{RT} (95 % level of confidence, $k = 2,0$)	3,22	3,52	mm
$\Delta\bar{D}_{RT} + U_{RT}$	3,62	4,12	mm
$\Delta\bar{D}_{RT} - U_{RT}$	-2,82	-2,92	mm
Positive tolerance	5,00	6,00	mm
Negative tolerance	-5,00	-6,00	mm

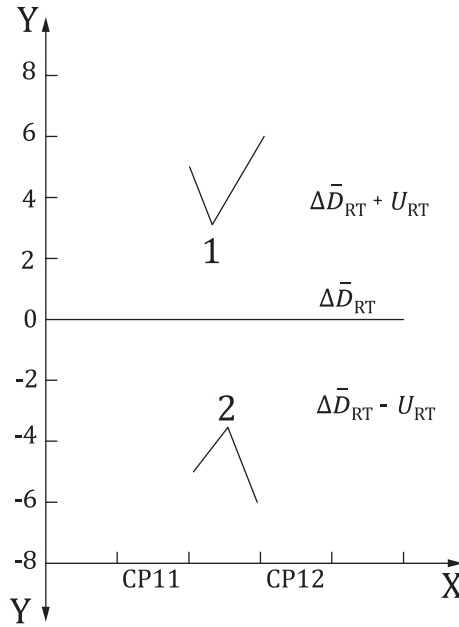

Key

- X check point
- Y deviation from reference (mm)
- 1 positive tolerance limit
- 2 negative tolerance limit

Figure C.1 — Average deviation and expanded uncertainty at range test

Table C.4 — Test results

	CP11	CP12
Deviation of average value at range test:	$\Delta\bar{D}_{RT} = +0,4$ mm	$\Delta\bar{D}_{RT} = +0,6$ mm
Expanded uncertainty of single measurements: (level of confidence 95 %, $k = 2,0$)	$U_{RT} = 3,2$ mm	$U_{RT} = 3,5$ mm
Result:	within specification	within specification

C.2 Example 4

Table C.5 — Performance specifications

Specification of range and accuracy with favourable conditions ^a :	Range	120 m
	Accuracy	±1,0 mm, from 20 m additional 0,05 mm/m (±6 mm at 120 m)
Specification of range and accuracy with unfavourable conditions ^b	Range	70 m
	Accuracy	±2 mm, from 20 m additional 0,1 mm/m (±7 mm at 70 m)
^a White diffuse reflecting target, low background illumination, temperatures about 20 °C		
^b 10 % to 100 % diffuse target reflectivity, high background illumination, temperatures from -10 °C to +50 °C		

Table C.6 — Range test measurements

Measurement	CP11	CP12	Unit
Conditions ^a	BG low	BG high	
\bar{D}_{REF}	120,035 0	69,995 0	mm
M 01	120,033	69,999	mm
M 02	120,035	69,994	mm
M 03	n.m.	69,997	mm
M 04	120,034	70,000	mm
M 05	120,038	69,995	mm
M 06	n.m.	69,990	mm
M 07	n.m.	n.m.	mm
M 08	120,036	69,999	mm
M 09	120,039	69,993	mm
M 10	n.m.	69,996	mm
^a Air temperature =25 °C, air pressure = 970 hPa, relative air humidity = 50 %.			

Table C.7 — Range test calculations

Calculation	CP11	CP12	Unit
Condition	BG low	BG high	
\bar{D}_{RT}	120,035 8	69,995 9	m
$\Delta\bar{D}_{RT}$	0,83	0,89	mm
u_{REF}	1,00	1,00	mm
u_{RM} ($R_M=1,0$ mm)	0,29	0,29	mm
u_{RT}	2,32	3,26	mm
$u_{C,RT}$	2,54	3,42	mm
U_{RT} (95 % level of confidence, $k = 2,0$)	5,08	6,84	mm
$\Delta\bar{D}_{RT} + U_{RT}$	5,91	7,73	mm
$\Delta\bar{D}_{RT} - U_{RT}$	-4,25	-5,95	mm
Positive tolerance	6,0	7,0	mm
Negative tolerance	-6,0	-7,0	mm

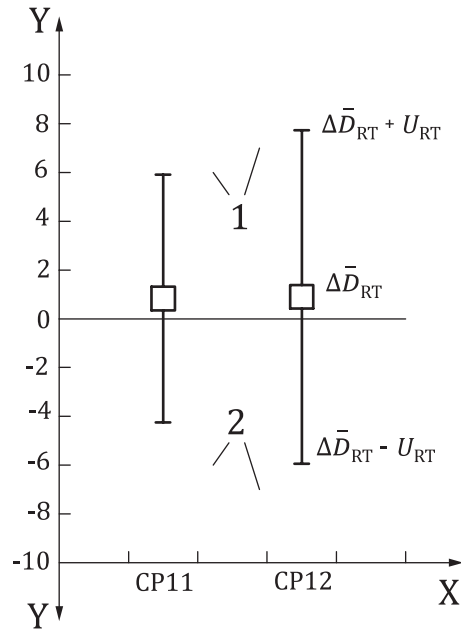

Key

- X range (m)
- Y deviation from reference (mm)
- 1 positive tolerance limit
- 2 negative tolerance limit

Figure C.2 — Average deviation and expanded uncertainty at range test

Table C.8 — Test results

	CP11	CP12
Deviation of average value at range test:	$\Delta\bar{D}_{RT} = +0,8$ mm	$\Delta\bar{D}_{RT} = +0,9$ mm
Expanded uncertainty of single measurements: (level of confidence 95 %, $k = 2,0$)	$U_{RT} = 5,1$ mm	$U_{RT} = 6,8$ mm
Result:	out of specification^a	out of specification
^a Out of specification as only six from 10 trials could perform a measurement.		

Annex D (informative)

Background illumination simulation

A possible setup for background illumination simulation is shown in [Figure D.1](#). A fixed target is illuminated by a lamp with a light spectrum and a density similar to daylight. In this case, the device under test is moved from one checkpoint to the next. The reference system (REF) should be able to determine the distance between the fixed target and the movable device under test.

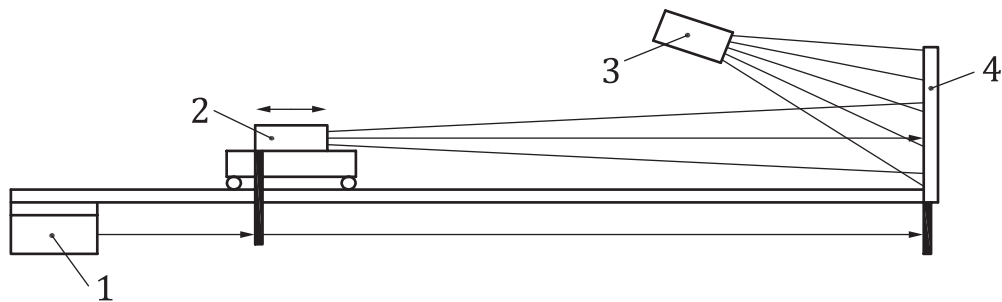

Key

- 1 REF
- 2 DUT
- 3 lamp
- 4 target

Figure D.1 — Setup for front side background illumination simulation

Advantage: The simulation of daylight influences is very realistic.

Disadvantages: A very powerful lamp or a combination of various lamps is required. The device under test with all the connections for automatic testing has to be moveable. At close distances to the target, the powerful lamp heats the device under test significantly.

Annex E (informative)

Target plates

Table E.1 — Target plate examples

Target plate (diffuse reflectance) ^a	Size mm	Reflectance at 635 nm	Depth of penetration mm	Comments
Spectralon reflectance target (Labsphere)	254 × 254	0,99	>2,0	With calibration certificate (NIST). Use only as reference for relative measurement of reflectance.
Glass or aluminium plate with Durafluct Reflectance Coating (Labsphere)	adjustable	0,94 .. 0,96	<1,0	For outdoor use in case of testing range specifications.
Glass or aluminium plate with matt white self-adhesive foil (e.g. 3M or Avery)	adjustable	0,95 .. 1,0	<0,2	For general use in case of testing range and/or accuracy specifications
^a The items in this column are examples of suitable products available commercially. This information is given for the convenience of users of this document and does not constitute an endorsement by ISO of these products.				

Annex F (informative)

Typical characteristics of targets

On targets like bricks, concrete and white painted walls, laser light is reflected mostly in a diffuse way. A complete matte material scatters the laser light evenly in all directions, reflecting the radiation independently of the incident angle. Therefore, a laser distance meter is able to receive a small portion of the laser light which was sent out, even when the laser beam hits the target under a small angle in reference to the target surface. Targets with a sleek surface reflect the laser light in a less diffuse and more directional way. Therefore, the amount of the reflected laser light that comes back to the laser distance meter depends significantly on the incident angle of the laser beam in reference to the target surface.

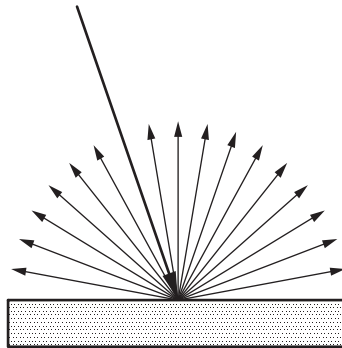

Figure F.1 — Ideal diffuse reflection (Lambertian surface)

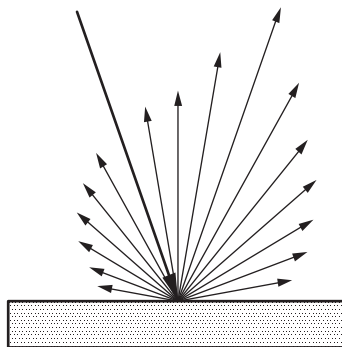

Figure F.2 — Diffuse reflection with directional component

A matte white and plane surface has by definition a diffuse reflectance of 1,0 (100 %). This is the reason why a sleek and plane surface might have a reflectance of $>1,0$, depending on the incident angle of the laser beam, e.g. measuring on a polished plane metal surface in a perfect perpendicular position will reflect the laser beam nearly completely into the receiver optics. In comparison with the received portion of laser light reflected on a complete matte and white target, the portion of reflected laser light in this case will be many times higher.

Table F.1 — Reflectance and laser penetration of typical target materials

Target	Reflectance at 635 nm	Average depth of penetration mm	Comments
White painted wall	0,9 ... 1,0	<0,5	
Concrete, dry	0,3 ... 0,4	1 ...20	Air bubbles lead to deviations
Concrete, wet	0,2 ...0,3	1 ...20	Air bubbles lead to deviations
Granite stone	0,3 ... 0,4	<1	
White marble	0,6 ... 0,8	up to 5	Danger of inaccurate measurements
Red brick	0,2 ... 0,4	<1	
Oak wood	0,6 ... 0,8	<2	
Balsa wood	0,7 ... 0,8	>2	Danger of inaccurate measurements
Styrofoam	0,3 ... 0,4	>5	Danger of inaccurate measurements
Polystyrol 495F lightgrey	0,5	<0,5	
Polystyrol 495F red	0,6	>2	Danger of inaccurate measurements
Polystyrol 495F black	0,4	<0,3	
Black velvet	0,05 ... 0,1	1...2	
Aluminium matt	1,0 ... 1,5	<0,3	Danger of multi-path measurements
Aluminium polished	2,0 ... 10	<0,1	Danger of multi-path measurements

Annex G (informative)

Typical alignment issues

Due to mechanical and optical tolerances of the complete laser emitting system, handheld laser distance meters often do not have a perfectly aligned laser beam in reference to their defined reference surface. The deviation of the laser beam from the ideal direction makes necessary that the instrument needs to be aligned in a way that the laser hits the target in the centre point at shortest and at longest distances (see [Figure G.1](#)). Alignment might be necessary in horizontal as well as in vertical direction. This could lead to an additional offset error as the laser foot point at the reference surface of the device under test could be moved away from the reference surface of the distance measurement test setup, depending on the mechanical situation and the direction of the corrective alignment (see [Figure G.2](#)). It is emphasized that the reference lengths are still to be determined with respect to the reference surface of the distance measurement test setup. A possible gap between the laser foot point of the reference surface of the device under test and the reference surface of the distance measurement test setup due to tilting shall not be corrected artificially in the measurement results.

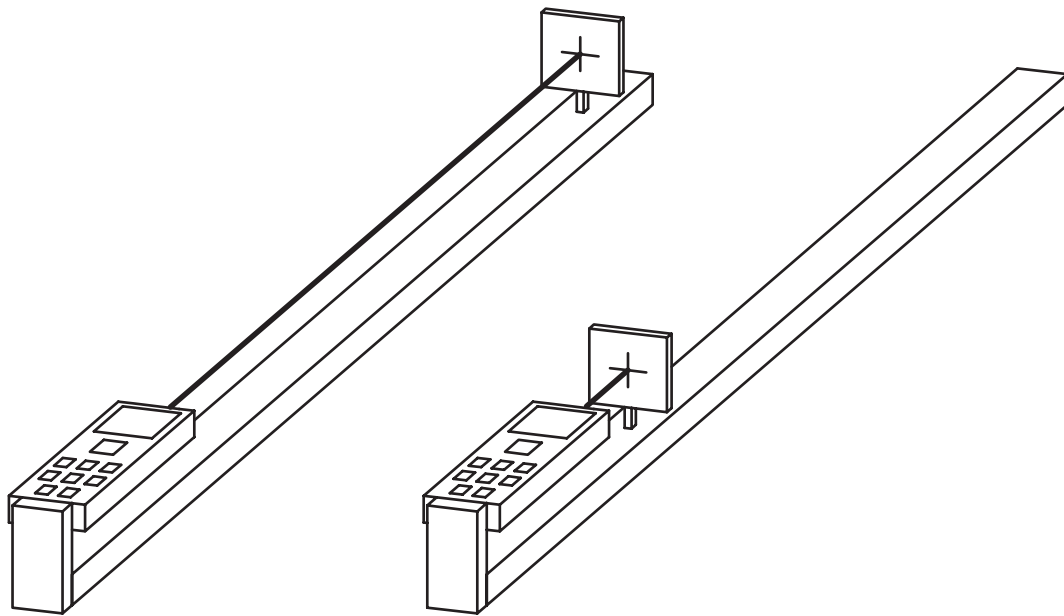
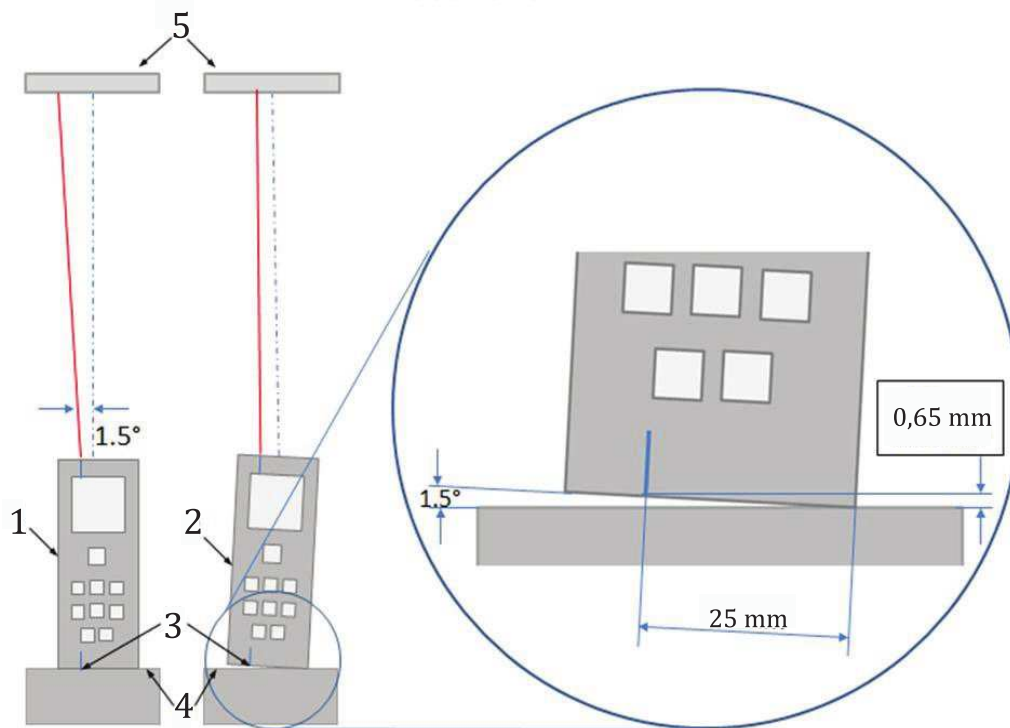

Figure G.1 — Correct aligned device under test when laser spot hits target at centre mark at longest distance and at shortest distance



Key

- 1 device under test completely attached to the reference surface of the test setup
- 2 device under test aligned with laser beam perpendicularly to the target
- 3 laser foot points at the reference surface of the device under test
- 4 reference surfaces of the distance measurement test setup
- 5 targets

Figure G.2 — Example of an additional offset error due to correct aligned device under test

Bibliography

- [1] ISO 17123-1, *Optics and optical instruments — Field procedures for testing geodetic and surveying instruments — Part 1: Theory*
- [2] ISO 17123-2, *Optics and optical instruments — Field procedures for testing geodetic and surveying instruments — Part 2: Levels*
- [3] ISO 17123-3, *Optics and optical instruments — Field procedures for testing geodetic and surveying instruments — Part 3: Theodolites*
- [4] ISO 17123-4, *Optics and optical instruments — Field procedures for testing geodetic and surveying instruments — Part 4: Electro-optical distance meters (EDM measurements to reflectors)*
- [5] ISO 17123-5, *Optics and optical instruments — Field procedures for testing geodetic and surveying instruments — Part 5: Total stations*
- [6] ISO 17123-6, *Optics and optical instruments — Field procedures for testing geodetic and surveying instruments — Part 6: Rotating lasers*
- [7] ISO 17123-7, *Optics and optical instruments — Field procedures for testing geodetic and surveying instruments — Part 7: Optical plumbing instruments*
- [8] ISO 17123-8, *Optics and optical instruments — Field procedures for testing geodetic and surveying instruments — Part 8: GNSS field measurement systems in real-time kinematic (RTK)*
- [9] ISO 21748, *Guidance for the use of repeatability, reproducibility and trueness estimates in measurement uncertainty estimation*
- [10] ISO 80000-3, *Quantities and units — Part 3: Space and time*
- [11] ISO/TS 21749, *Measurement uncertainty for metrological applications — Repeated measurements and nested experiments*
- [12] ISO/IEC Guide 98-1, *Uncertainty of measurement — Part 1: Introduction to the expression of uncertainty in measurement*
- [13] EA-04/02 (1999), *Expression of the uncertainty of measurement in calibration*
- [14] Rueger, J.M., Springer-Verlag. *Electronic Distance Measurement — An Introduction*. Berlin-Heidelberg-New York

