

---

---

**Acoustics — Field measurement of  
sound insulation in buildings and of  
building elements —**

**Part 3:  
Façade sound insulation**

*Acoustique — Mesurage in situ de l'isolement acoustique  
des bâtiments et des éléments de construction —  
Partie 3: Isolement aux bruits de façades*



**COPYRIGHT PROTECTED DOCUMENT**

© ISO 2016, Published in Switzerland

All rights reserved. Unless otherwise specified, no part of this publication may be reproduced or utilized otherwise in any form or by any means, electronic or mechanical, including photocopying, or posting on the internet or an intranet, without prior written permission. Permission can be requested from either ISO at the address below or ISO's member body in the country of the requester.

ISO copyright office  
Ch. de Blandonnet 8 • CP 401  
CH-1214 Vernier, Geneva, Switzerland  
Tel. +41 22 749 01 11  
Fax +41 22 749 09 47  
copyright@iso.org  
www.iso.org

# Contents

Page

<b>Foreword</b> .....	<b>v</b>
<b>Introduction</b> .....	<b>vi</b>
<b>1 Scope</b> .....	<b>1</b>
<b>2 Normative references</b> .....	<b>2</b>
<b>3 Terms and definitions</b> .....	<b>3</b>
<b>4 Instrumentation</b> .....	<b>8</b>
4.1 General .....	8
4.2 Calibration .....	8
4.3 Verification .....	8
<b>5 Frequency range</b> .....	<b>9</b>
<b>6 General</b> .....	<b>9</b>
<b>7 Indoor sound pressure level measurements</b> .....	<b>11</b>
7.1 General .....	11
7.2 Default procedure .....	11
7.2.1 Fixed microphone positions .....	11
7.2.2 Mechanized continuously-moving microphone .....	11
7.2.3 Manually scanned microphone .....	11
7.2.4 Minimum distances for microphone positions .....	13
7.2.5 Averaging times .....	13
7.2.6 Calculation of energy-average sound pressure levels .....	14
7.3 Low-frequency procedure (element or global loudspeaker methods) .....	15
7.3.1 General .....	15
7.3.2 Microphone positions .....	15
7.3.3 Averaging time .....	15
7.3.4 Calculation of low-frequency energy-average sound pressure levels .....	16
7.4 Background noise (default and low-frequency procedure) .....	16
7.4.1 General .....	16
7.4.2 Correction to the signal level for background noise .....	17
<b>8 Reverberation time measurements in the receiving room (default and low-frequency procedure)</b> .....	<b>17</b>
8.1 General .....	17
8.2 Generation of sound field .....	17
8.3 Default procedure .....	18
8.4 Low-frequency procedure .....	18
8.5 Interrupted noise method .....	18
8.6 Integrated impulse response method .....	18
<b>9 Outdoor measurements using a loudspeaker as a sound source (default and low-frequency procedure)</b> .....	<b>19</b>
9.1 General .....	19
9.2 Generation of the sound field .....	19
9.3 Loudspeaker requirements .....	19
9.4 Loudspeaker positions .....	20
9.5 Element loudspeaker method .....	20
9.5.1 Outdoor sound pressure level measurements on the test surface .....	20
9.6 Global loudspeaker method .....	21
9.6.1 Outdoor sound pressure level measurements near the façade .....	21
9.6.2 Large rooms or façades comprising more than one outside wall .....	21
9.6.3 Calculation of measurement results .....	21
<b>10 Outdoor measurements using road traffic as a sound source (default procedure)</b> .....	<b>21</b>
10.1 General .....	21

10.2	Test requirements .....	22
10.3	Element road traffic method .....	22
10.3.1	General .....	22
10.3.2	Requirements on road traffic and façade geometry .....	22
10.3.3	Outdoor sound pressure level measurements on the test surface .....	23
10.4	Global road traffic method .....	23
10.4.1	Outdoor sound pressure level measurements at a distance of 2 m in front of the façade .....	23
10.4.2	Calculation of measurement results .....	24
<b>11</b>	<b>Conversion to octave bands</b> .....	<b>24</b>
<b>12</b>	<b>Expression of results</b> .....	<b>25</b>
<b>13</b>	<b>Uncertainty</b> .....	<b>26</b>
<b>14</b>	<b>Test report</b> .....	<b>26</b>
<b>Annex A</b>	<b>(normative) Determination of area, S</b> .....	<b>27</b>
<b>Annex B</b>	<b>(normative) Control of sound transmission through the wall surrounding the test specimen</b> .....	<b>28</b>
<b>Annex C</b>	<b>(normative) Requirements for loudspeakers</b> .....	<b>29</b>
<b>Annex D</b>	<b>(informative) Examples of verification of test requirements</b> .....	<b>30</b>
<b>Annex E</b>	<b>(informative) Measurements with aircraft and railway traffic noise (default procedure)</b>	<b>31</b>
<b>Annex F</b>	<b>(informative) Forms for recording results</b> .....	<b>35</b>
<b>Bibliography</b>	.....	<b>37</b>

## Foreword

ISO (the International Organization for Standardization) is a worldwide federation of national standards bodies (ISO member bodies). The work of preparing International Standards is normally carried out through ISO technical committees. Each member body interested in a subject for which a technical committee has been established has the right to be represented on that committee. International organizations, governmental and non-governmental, in liaison with ISO, also take part in the work. ISO collaborates closely with the International Electrotechnical Commission (IEC) on all matters of electrotechnical standardization.

The procedures used to develop this document and those intended for its further maintenance are described in the ISO/IEC Directives, Part 1. In particular the different approval criteria needed for the different types of ISO documents should be noted. This document was drafted in accordance with the editorial rules of the ISO/IEC Directives, Part 2 (see [www.iso.org/directives](http://www.iso.org/directives)).

Attention is drawn to the possibility that some of the elements of this document may be the subject of patent rights. ISO shall not be held responsible for identifying any or all such patent rights. Details of any patent rights identified during the development of the document will be in the Introduction and/or on the ISO list of patent declarations received (see [www.iso.org/patents](http://www.iso.org/patents)).

Any trade name used in this document is information given for the convenience of users and does not constitute an endorsement.

For an explanation on the meaning of ISO specific terms and expressions related to conformity assessment, as well as information about ISO's adherence to the WTO principles in the Technical Barriers to Trade (TBT) see the following URL: [Foreword - Supplementary information](#)

The committee responsible for this document is ISO/TC 43, *Acoustics*, Subcommittee SC 2, *Building acoustics*.

This first edition cancels and replaces ISO 140-5:1998 and ISO 140-14:2004, which have been technically revised.

ISO 16283 consists of the following parts, under the general title *Acoustics — Field measurement of sound insulation in buildings and of building elements*:

- *Part 1: Airborne sound insulation*
- *Part 2: Impact sound insulation*
- *Part 3: Façade sound insulation*

## **Introduction**

ISO 16283 (all parts) describes procedures for field measurements of sound insulation in buildings. Airborne, impact, and façade sound insulation are described in ISO 16283-1, ISO 16283-2, and in this part of ISO 16283, respectively.

Field sound insulation measurements that were described previously in ISO 140-4, ISO 140-5, and ISO 140-7 were (a) primarily intended for measurements where the sound field could be considered to be diffuse and (b) not explicit as to whether operators could be present in the rooms during the measurement. ISO 16283 differs from ISO 140-4, ISO 140-5, and ISO 140-7 in that (a) it applies to rooms in which the sound field can or cannot approximate to a diffuse field, (b) it clarifies how operators can measure the sound field using a hand-held microphone or sound level metre, and (c) it includes additional guidance that was previously contained in ISO 140-14.

NOTE Survey test methods for field measurements of façade sound insulation are dealt with in ISO 10052.

# Acoustics — Field measurement of sound insulation in buildings and of building elements —

## Part 3: Façade sound insulation

### 1 Scope

This part of ISO 16283 specifies procedures to determine the airborne sound insulation of façade elements (element methods) and whole façades (global methods) using sound pressure measurements. These procedures are intended for room volumes in the range from 10 m<sup>3</sup> to 250 m<sup>3</sup> in the frequency range from 50 Hz to 5 000 Hz.

The test results can be used to quantify, assess, and compare the airborne sound insulation in unfurnished or furnished rooms where the sound field can or cannot approximate to a diffuse field. The measured airborne sound insulation is frequency-dependent and can be converted into a single number quantity to characterize the acoustic performance using the rating procedures in ISO 717-1.

The element methods aim to estimate the sound reduction index of a façade element, for example, a window. The most accurate element method uses a loudspeaker as an artificial sound source. Other less accurate element methods use available traffic noise. The global methods, on the other hand, aim to estimate the outdoor/indoor sound level difference under actual traffic conditions. The most accurate global methods use the actual traffic as sound source. A loudspeaker can be used as an artificial sound source when there is insufficient level from traffic noise inside the room. An overview of the methods is given in [Table 1](#).

The element loudspeaker method yields an apparent sound reduction index which, under certain circumstances, can be compared with the sound reduction index measured in laboratories in accordance with ISO 10140. This method is the preferred method when the aim of the measurement is to evaluate the performance of a specified façade element in relation to its performance in the laboratory.

The element road traffic method will serve the same purposes as the element loudspeaker method. It is particularly useful when, for different practical reasons, the element loudspeaker method cannot be used. These two methods will often yield slightly different results. The road traffic method tends to result in lower values of the sound reduction index than the loudspeaker method. In [Annex D](#), this road traffic method is supplemented by the corresponding aircraft and railway traffic methods.

The global road traffic method yields the real reduction of a façade in a given place relative to a position 2 m in front of the façade. This method is the preferred method when the aim of the measurement is to evaluate the performance of a whole façade, including all flanking paths, in a specified position relative to nearby roads. The result cannot be compared with that of laboratory measurements.

The global loudspeaker method yields the sound reduction of a façade relative to a position that is 2 m in front of the façade. This method is particularly useful when, for practical reasons, the real source cannot be used; however, the result cannot be compared with that of laboratory measurements.

**Table 1 — Overview of the different measurement methods**

No.	Method Element	Reference in this part of ISO 16283	Result	Field of application
1	Element loudspeaker	<a href="#">9.5</a>	$R'_{45^\circ}$	Preferred method to estimate the apparent sound reduction index of façade elements
2	Element road traffic	<a href="#">10.3</a>	$R'_{tr,s}$	Alternative to method No.1 when road traffic as a sound source provides a sufficient level
3	Element railway traffic	<a href="#">Annex E</a>	$R'_{rt,s}$	Alternative to method No.1 when railway traffic as a sound source provides a sufficient level
4	Element aircraft traffic	<a href="#">Annex E</a>	$R'_{at,s}$	Alternative to method No.1 when aircraft traffic as a sound source provides a sufficient level
	<b>Global</b>			
5	Global loudspeaker	<a href="#">9.6</a>	$D_{ls,2m,nT}$ $D_{ls,2m,n}$	Alternative to methods Nos. 6, 7, and 8
6	Global road traffic	<a href="#">10.4</a>	$D_{tr,2m,nT}$ $D_{tr,2m,n}$	Preferred method to estimate the global sound insulation of a façade exposed to road traffic as a sound source
7	Global railway traffic	<a href="#">Annex E</a>	$D_{rt,2m,nT}$ $D_{rt,2m,n}$	Preferred method to estimate the global sound insulation of a façade exposed to railway traffic as a sound source
8	Global aircraft traffic	<a href="#">Annex E</a>	$D_{at,2m,nT}$ $D_{at,2m,n}$	Preferred method to estimate the global sound insulation of a façade exposed to aircraft traffic as a sound source

## 2 Normative references

The following documents, in whole or in part, are normatively referenced in this document and are indispensable for its application. For dated references, only the edition cited applies. For undated references, the latest edition of the referenced document (including any amendments) applies.

ISO 717-1, *Acoustics — Rating of sound insulation in buildings and of building elements — Part 1: Airborne sound insulation*

ISO 3382-2, *Acoustics — Measurement of room acoustic parameters — Part 2: Reverberation time in ordinary rooms*

ISO 12999-1, *Acoustics — Determination and application of measurement uncertainties in building acoustics — Part 1: Sound insulation*

ISO 15712-3, *Building acoustics — Estimation of acoustic performance of buildings from the performance of elements — Part 3: Airborne sound insulation against outdoor sound*

ISO 18233, *Acoustics — Application of new measurement methods in building and room acoustics*

IEC 60942, *Electroacoustics — Sound calibrators*

IEC 61183, *Electroacoustics — Random-incidence and diffuse-field calibration of sound level meters*

IEC 61260, *Electroacoustics — Octave-band and fractional-octave-band filters*

IEC 61672-1, *Electroacoustics — Sound level meters — Part 1: Specifications*



### 3 Terms and definitions

For the purposes of this document, the following terms and definitions apply.

#### 3.1

##### **average outdoor sound pressure level on the test surface**

$L_{1,s}$

ten times the common logarithm of the ratio of the surface and time average of the squared sound pressure to the square of the reference sound pressure, the surface average being taken over the entire test surface including reflecting effects from the test specimen and façade

Note 1 to entry:  $L_{1,s}$  is expressed in decibels.

#### 3.2

##### **average outdoor sound pressure level at a distance 2m in front of the façade**

$L_{1,2m}$

ten times the common logarithm of the ratio of the time average of the squared sound pressure to the square of the reference sound pressure, at a position 2 m in front of the façade

Note 1 to entry:  $L_{1,2m}$  is expressed in decibels.

#### 3.3

##### **energy-average sound pressure level in a room**

$L_2$

ten times the common logarithm of the ratio of the space and time average of the squared sound pressure to the square of the reference sound pressure, the space average is taken over the central zone of the room where the nearfield radiation from the room boundaries has negligible influence

Note 1 to entry:  $L_2$  is expressed in decibels.

#### 3.4

##### **corner sound pressure level in a room**

$L_{2,Corner}$

ten times the common logarithm of the ratio of the highest time average squared sound pressure from the set of corner measurements to the square of the reference sound pressure, for the low-frequency range (50 Hz, 63 Hz, and 80 Hz one-third octave bands)

Note 1 to entry:  $L_{2,Corner}$  is expressed in decibels.

#### 3.5

##### **low-frequency energy-average sound pressure level in a room**

$L_{2,LF}$

ten times the common logarithm of the ratio of the space and time average of the squared sound pressure to the square of the reference sound pressure in the low-frequency range (50 Hz, 63 Hz, and 80 Hz one-third octave bands) where the space average is a weighted average that is calculated using the room corners where the sound pressure levels are highest and the central zone of the room where the nearfield radiation from the room boundaries has negligible influence

Note 1 to entry:  $L_{2,LF}$  is expressed in decibels.

Note 2 to entry:  $L_{2,LF}$  is an estimate of the energy-average sound pressure level for the entire room volume.

#### 3.6

##### **reverberation time**

$T$

time required for the sound pressure level in a room to decrease by 60 dB after the sound source has stopped

Note 1 to entry:  $T$  is expressed in seconds.

**3.7 background noise level**  
measured sound pressure level in the receiving room from all sources except the sound source used for the measurement

**3.8 fixed microphone**  
microphone that is fixed in space by using a device such as a tripod so that it is stationary

**3.9 mechanized continuously-moving microphone**  
microphone that is mechanically moved with approximately constant angular speed in a circle, or is mechanically swept along a circular path where the angle of rotation about a fixed axis is between 270° and 360°

**3.10 manually-scanned microphone**  
microphone attached to a hand-held sound level metre or an extension rod that is moved by a human operator along a prescribed path

**3.11 manually-held microphone**  
microphone attached to a hand-held sound level metre or a rod that is hand-held at a fixed position by a human operator at a distance at least an arm's length from the trunk of the operator's body

**3.12 apparent sound reduction index**  
 $R'_{45^\circ}$   
measure of the airborne sound insulation of a building element when the sound source is a loudspeaker at an angle of incidence is 45° and the outside microphone position is on the test surface, which is given by ten times the common logarithm of the ratio of the sound power,  $W_{1,45^\circ}$ , which is incident on a test element when the angle of sound incidence is 45° to the total sound power radiated into the receiving room if, in addition to the sound power,  $W_2$ , radiated by the test element, the sound power,  $W_3$ , radiated by flanking elements or by other components, is significant

$$R'_{45^\circ} = 10 \lg \frac{W_{1,45^\circ}}{W_2 + W_3}$$

for which the apparent sound reduction index is evaluated using the following formula:

$$R'_{45^\circ} = L_{1,s} - L_2 + 10 \lg \frac{S}{A} - 1,5 \text{dB}$$

where

$S$  is the area of the test specimen, in square metres, determined as given in [Annex A](#);

$A$  is the equivalent absorption area of the receiving room, in square metres.

Note 1 to entry:  $R'_{45^\circ}$  is expressed in decibels.

Note 2 to entry: In general, the sound power transmitted into the receiving room consists of the sum of several components from different elements (window, ventilator, door, wall, etc.).

Note 3 to entry: The second formula is based on the assumption that the sound is incident from one angle only, 45°, and the sound field in the receiving room approximates to a diffuse field.

### 3.13 apparent sound reduction index

$R'_{tr,s}$

measure of the airborne sound insulation of a building element when the sound source is road traffic and the outside microphone position is on the test surface for which the apparent sound reduction index is evaluated using the following formula:

$$R'_{tr,s} = L_{1,s} - L_2 + 10 \lg \frac{S}{A} - 3 \text{dB}$$

where

$S$  is the area of the test specimen, in square metres, determined as given in [Annex A](#);

$A$  is the equivalent absorption area of the receiving room, in square metres.

Note 1 to entry:  $R'_{tr,s}$  is expressed in decibels.

Note 2 to entry: The formula is based on the assumption that the sound is incident from all angles, and the sound field in the receiving room approximates to a diffuse field.

### 3.14 level difference

$D_{2m}$

level difference between  $L_{1,2m}$  and  $L_2$  evaluated using the following formula:

$$D_{2m} = L_{1,2m} - L_2$$

Note 1 to entry:  $D_{2m}$  is expressed in decibels.

Note 2 to entry: The notation is  $D_{tr,2m}$  when traffic noise is used as the sound source, and  $D_{ls,2m}$  when a loudspeaker is used.

### 3.15 standardized level difference

$D_{2m,nT}$

level difference ([3.14](#)) that is standardized to a reference value of the *reverberation time* ([3.6](#)) in the receiving room and calculated using the following formula:

$$D_{2m,nT} = D_{2m} + 10 \lg \frac{T}{T_0}$$

where

$T$  is the reverberation time in the receiving room;

$T_0$  is the reference reverberation time; for dwellings,  $T_0 = 0,5$  s.

Note 1 to entry:  $D_{2m,nT}$  is expressed in decibels.

Note 2 to entry: The level difference is referenced to a reverberation time of 0,5 s because in dwellings with furniture the reverberation time has been found to be reasonably independent of volume and frequency and to be approximately equal to 0,5 s.

Note 3 to entry: The notation is  $D_{tr,2m,nT}$  when traffic noise is used as the sound source, and  $D_{ls,2m,nT}$  when a loudspeaker is used.

### 3.16

#### normalized level difference

$D_{2m,n}$

level difference (3.14) that is normalized to a reference value of the absorption area in the receiving room and calculated using the following formula:

$$D_{2m,n} = D_{2m} - 10 \lg \frac{A}{A_0}$$

where

$A_0$  is the reference absorption area; for dwellings,  $A_0 = 10 \text{ m}^2$

Note 1 to entry:  $D_{2m,n}$  is expressed in decibels.

Note 2 to entry: The notation is  $D_{tr,2m,n}$  when traffic noise is used as the sound source, and  $D_{ls,2m,n}$  when a loudspeaker is used.

### 3.17

#### equivalent absorption area

$A$

sound absorption area which is calculated using Sabine's formula

$$A = \frac{0,16V}{T}$$

where

$V$  is the receiving room volume, in cubic metres;

$T$  is the reverberation time in the receiving room.

Note 1 to entry:  $A$  is expressed in square metres.

### 3.18

#### single event level

$L_E$

single event level of a discrete noise event calculated using the following formula:

$$L_E = 10 \lg \frac{1}{t_0} \int_{t_1}^{t_2} \frac{p^2(t)}{p_0^2} dt$$

where

$p(t)$  is the instantaneous sound pressure, in Pascals;

$t_2 - t_1$  is a stated time interval long enough to encompass all significant sound energy of a stated event;

$p_0$  is the reference sound pressure, with  $p_0 = 20 \text{ } \mu\text{Pa}$ ;

$t_0$  is the reference duration, with  $t_0 = 1 \text{ s}$ .

Note 1 to entry:  $L_E$  is expressed in decibels.

### 3.19 single event level difference

#### $D_{E,2m}$

level difference between the outdoor *single event level* (3.18),  $L_{E1,2m}$ , and the space and time average single event level,  $L_{E2}$ , in the receiving room and calculated using the following formula:

$$D_{E,2m} = L_{E1,2m} - L_{E2}$$

Note 1 to entry:  $D_{E,2m}$  is expressed in decibels.

Note 2 to entry: The notation is  $D_{at,E,2m}$  when aircraft traffic is used as the sound source and  $D_{rt,E,2m}$  when railway traffic is used as the sound source.

### 3.20 standardized single event level difference

#### $D_{E,2m,nT}$

*single event level difference* (3.19) that is standardized to a reference value of the *reverberation time* (3.6) in the receiving room and calculated using the following formula:

$$D_{E,2m,nT} = D_{E,2m} + 10 \lg \frac{T}{T_0}$$

Note 1 to entry:  $D_{E,2m,nT}$  is expressed in decibels.

Note 2 to entry: The notation is  $D_{at,E,2m,nT}$  when aircraft traffic is used as the sound source, and  $D_{rt,E,2m,nT}$  when railway traffic is used as the sound source.

### 3.21 normalized single event level difference

#### $D_{E,2m,n}$

*single event level difference* (3.19) that is normalized to a reference value of the absorption area in the receiving room and calculated using the following formula:

$$D_{E,2m,n} = D_{E,2m} - 10 \lg \frac{A}{A_0}$$

Note 1 to entry:  $D_{E,2m,n}$  is expressed in decibels.

Note 2 to entry: The notation is  $D_{at,E,2m,n}$  when aircraft traffic is used as the sound source, and  $D_{rt,E,2m,n}$  when railway traffic is used as the sound source.

### 3.22 apparent sound reduction index

#### $R'_{at,s}$

measure of the airborne sound insulation of a building element when the sound source is aircraft traffic and the outside microphone position is on the test surface, it is calculated using the following formula:

$$R'_{at,s} = L_{E1,s} - L_{E2} + 10 \lg \frac{S}{A} - 3 \text{dB}$$

where

$L_{E1,s}$  is the spatial average value of the single event level on the surface of the test specimen which includes the effect of reflections from the test specimen and façade;

$L_{E2}$  is the average value of the single event level in the receiving room;

$S$  is the area of the test specimen, in square metres;

$A$  is the equivalent absorption area of the receiving room, in square metres.

Note 1 to entry:  $R'_{at,s}$  is expressed in decibels.

### 3.23

#### apparent sound reduction index

$R'_{rt,s}$

measure of the airborne sound insulation of a building element when the sound source is railway traffic and the outside microphone position is on the test surface, it is calculated using the following formula:

$$R'_{rt,s} = L_{E1,s} - L_{E2} + 10 \lg \frac{S}{A} - 3 \text{dB}$$

where

$L_{E1,s}$  is the spatial average value of the single event level on the surface of the test specimen which includes the effect of reflections from the test specimen and façade;

$L_{E2}$  is the average value of the single event level in the receiving room;

$S$  is the area of the test specimen, in square metres;

$A$  is the equivalent absorption area of the receiving room, in square metres.

Note 1 to entry:  $R'_{rt,s}$  is expressed in decibels.

## 4 Instrumentation

### 4.1 General

The instruments for measuring sound pressure levels, including microphone(s) as well as cable(s), windscreen(s), recording devices, and other accessories, if used, shall meet the requirements for a class 0 or 1 instrument according to IEC 61672-1 for random incidence application.

The microphone used for surface measurements shall have a maximum diameter of 13 mm.

Filters shall meet the requirements for a class 0 or class 1 instrument according to IEC 61260.

The reverberation time measurement equipment shall comply with the requirements defined in ISO 3382-2.

### 4.2 Calibration

At the beginning and at the end of every measurement session and at least at the beginning and the end of each measurement day, the entire sound pressure level measuring system shall be checked at one or more frequencies by means of a sound calibrator meeting the requirements for a class 0 or class 1 instrument according to IEC 60942. Each time the calibrator is used, the sound pressure level measured with the calibrator should be noted in the field documentation of the operator. Without any further adjustment, the difference between the readings of two consecutive checks shall be less or equal to 0,5 dB. If this value is exceeded, the results of measurements obtained after the previous satisfactory check shall be discarded.

### 4.3 Verification

Compliance of the sound pressure level measuring instrument, the filters and the sound calibrator with the relevant requirements shall be verified by the existence of a valid certificate of compliance. If applicable, random incidence response of the microphone shall be verified by a procedure from IEC 61183. All compliance testing shall be conducted by a laboratory being accredited or otherwise

nationally authorized to perform the relevant tests and calibrations and ensuring metrological traceability to the appropriate measurement standards.

Unless national regulations dictate otherwise, it is recommended that the sound calibrator should be calibrated at intervals not exceeding 1 year, the compliance of the instrumentation system with the requirements of IEC 61672-1 should be verified at intervals not exceeding two years, and the compliance of the filter set with the requirements of IEC 61260 should be verified at intervals not exceeding two years.

## 5 Frequency range

All quantities shall be measured using one-third octave band filters having at least the following centre frequencies, in hertz:

100, 125, 160, 200, 250, 315, 400, 500, 630, 800, 1 000, 1 250, 1 600, 2 000, 2 500, 3 150

If additional information in the low-frequency range is required, use one-third octave band filters with the following centre frequencies, in hertz:

50, 63, 80

If additional information in the high-frequency range is required, use one-third octave band filters with the following centre frequencies, in hertz:

4 000, 5 000

Measurement of additional information in the low- and high-frequency ranges is optional.

## 6 General

Determination of the façade sound insulation according to this part of ISO 16283 requires that the sound source is outdoors. The measurements that are required include the sound pressure levels near the façade and in the room with the source(s) operating, the background noise in the receiving room when the loudspeaker is switched off or the actual sources are not present, and the reverberation times in the receiving room.

For the element and global loudspeaker methods, two measurement procedures are described that shall be used for the sound pressure level, the reverberation time and the background noise; a default procedure and an additional low-frequency procedure. For the element and global road traffic methods, only the default procedure shall be used.

NOTE 1 At present, there is no experience using the low-frequency procedure with road traffic (or air or railway traffic) as a sound source, but problems may arise due to the uncertainty in ensuring that the signal is above background.

For the sound pressure level and the background noise, the default procedure for all frequencies is to use a fixed microphone or a manually-held microphone moved from one position to another, an array of fixed microphones, a mechanized continuously-moving microphone, or a manually-scanned microphone. These measurements are taken in the central zone of a room at positions away from the room boundaries. Different approaches are described to sample the sound pressure so that the operator can choose the most suitable approach. For the receiving room, the aim is to minimize the effect of background noise for which the operator shall decide whether it is advantageous to be present in the room in order to listen for intermittent background noise or to be outside the room to ensure that the background noise is unaffected by the operator.

For the sound pressure level and the background noise, the low-frequency procedure shall be used for the 50 Hz, 63 Hz, and 80 Hz one-third octave bands in the receiving room when its volume is smaller than 25 m<sup>3</sup> (calculated to the nearest cubic metre). This procedure is carried out in addition to the



default procedure and requires additional measurements of the sound pressure level in the corners of the receiving room using either a fixed microphone or a manually-held microphone.

NOTE 2 The low-frequency procedure is necessary in small rooms due to large spatial variations in the sound pressure level of the modal sound field. In these situations, corner measurements are used to improve the repeatability, reproducibility, and relevance to room occupants.

For the reverberation time, the low-frequency procedure shall be used for the 50 Hz, 63 Hz, and 80 Hz one-third octave bands in the receiving room when its volume is smaller than 25 m<sup>3</sup> (calculated to the nearest cubic metre).

If using methods of signal processing described in ISO 18233, the measurements shall be carried out using fixed microphones and shall not use a mechanized continuously-moving microphone, manually-held microphone or a manually-scanned microphone.

The sound fields in typical rooms (furnished or unfurnished) will rarely approximate to a diffuse sound field over the entire frequency range from 50 Hz to 5 000 Hz. The default and low-frequency procedures allow for measurements to be taken without any knowledge as to whether the sound field can be considered as diffuse or non-diffuse. For this reason, the sound field should not be modified for the purpose of the test by temporarily introducing additional furniture or diffusers into the receiving room (furnished or unfurnished).

NOTE 3 If measurements with additional diffusion are required, for example due to regulatory requirements or because the test result is to be compared with a laboratory measurement on a similar test element, then the introduction of three diffusers will usually be sufficient each with an area of at least 1,0 m<sup>2</sup>.

All measurement methods for the default procedure or the low-frequency procedure are equivalent. In case of dispute, the sound insulation determined using measurement methods without an operator inside the receiving room shall be taken to be the reference result.

NOTE 4 A reference result is defined because the background noise level with manual scanning is prone to variation in the self-generated noise from the operator. Significant variation does not tend to occur with fixed microphones or a mechanized continuously-moving microphone.

For the element methods where the purpose of the measurement is to obtain results for comparison with laboratory measurements, the following steps should be carried out.

- a) Verify that the façade element under test is in accordance with the specified construction and is properly mounted according to the manufacturer's instructions.
- b) Estimate the sound reduction index of the façade to ensure that the sound transmission through the wall surrounding the test specimen or flanking building elements does not contribute significantly to the sound pressure level in the receiving room. The estimation of whether the wall influences the sound insulation shall be performed according to ISO 15712-3.

In case of doubt about unacceptably high sound transmission through the wall surrounding the test specimen or flanking building elements, the procedure described in [Annex B](#) shall be carried out.

If the purpose of the measurement is to compare the sound insulation of a window with the results of laboratory measurements, verify in addition that the area of the test opening is representative of that of the laboratory measurement and that the niche opening and the window position in the niche do not deviate from the requirements given in ISO 10140.

NOTE 5 The sound insulation of windows and small façade elements depends on the dimensions; hence the sound insulation can differ considerably when such an element has dimensions that differ from the element tested in the laboratory. For window panes where the area varies from the laboratory test by up to 2:1, the sound insulation is unlikely to differ by more than 3 dB in the single-number quantity. For any element with an area that is larger than that tested in the laboratory, a lower sound insulation will generally result.

[Annex D](#) gives examples of verification checks.



## 7 Indoor sound pressure level measurements

### 7.1 General

Sound pressure level measurements are used to determine an average level in the receiving room with the sound source (loudspeaker or road traffic) in operation, the reverberation time in the receiving room, and the background noise level in the receiving room.

### 7.2 Default procedure

#### 7.2.1 Fixed microphone positions

Fixed microphones can be used without an operator in the room by using a microphone fixed on a tripod. Alternatively, the operator can be present in the room with the microphone fixed on a tripod, or with the operator using a manually-held microphone at a fixed position; in both cases the trunk of the operator's body shall remain at a distance at least an arm's length from the microphone.

A minimum of five microphone positions shall be used in the room. Each set of microphone positions shall be distributed within the maximum permitted space throughout the room. No two microphone positions shall lie in the same plane relative to the room boundaries and the positions shall not be in a regular grid.

Averaging times shall satisfy the requirements in [7.2.5.1](#).

#### 7.2.2 Mechanized continuously-moving microphone

The microphone shall be mechanically moved with approximately constant angular speed in a circle, or shall be mechanically swept along a circular path where the angle of rotation about a fixed axis is between  $270^\circ$  and  $360^\circ$ . The sweep radius for the circular traverse shall be at least 0,7 m. The plane of the traverse shall be inclined in order to cover a large proportion of the permitted room space and shall not lie in any plane that is less than  $10^\circ$  from any room surface (wall, floor, or ceiling).

The duration of a single traverse shall be at least 15 s. Each complete traverse may need to be repeated to satisfy the requirements on the averaging time in [7.2.5.2](#).

#### 7.2.3 Manually scanned microphone

##### 7.2.3.1 General

The manual-scanning path shall be a circle, a helix, a cylindrical-type path or three semicircles as shown in [Figure 1](#). A circle, helix, or cylindrical-type path shall be used in unfurnished or furnished rooms. If there is insufficient space in the room for the operator to use these paths, the path consisting of three semicircles shall be used. Each complete path may need to be repeated to satisfy the requirements on the averaging time in [7.2.5.3](#).

##### 7.2.3.2 Circle

The circular path is indicated in [Figure 1](#). The operator shall stand holding the microphone or sound level metre with outstretched arm while rotating the body through an angle of  $270^\circ$  to  $360^\circ$ . The plane of the circle shall be inclined in order to cover a large proportion of the permitted room space and shall not lie in any plane that is less than  $10^\circ$  from any room surface (wall, floor, or ceiling). If required, the knees can be bent to reduce the overall height of the microphone; this should always be done when the path is repeated at another position in the room. To minimize operator noise, it can be beneficial to pause the measurement mid-way along the path so the operator can change the position of the body before continuing the scan.

The operator shall aim to achieve a constant angular speed during the scan. The maximum angular speed shall be approximately  $20^\circ$  per second.

### 7.2.3.3 Helix

The helical path is indicated in [Figure 1](#). The operator holds the microphone or sound level metre with outstretched arm at a starting position that is 0,5 m above the floor then rotates the body at least twice through 360° from a crouched to a standing position, finishing with the microphone at a position that is no more than 0,5 m from the ceiling. To minimize operator noise, it can be beneficial to pause the measurement mid-way along the path so the operator can change the position of the body before continuing the scan.

The operator shall aim to achieve a constant angular speed during the scan. The maximum angular speed shall be approximately 20° per second.

### 7.2.3.4 Cylindrical-type

The cylindrical-type path is indicated in [Figure 1](#). The operator shall use a 0,3 m to 0,9 m extension rod to hold the microphone. For a right-handed operator, the path starts 0,5 m above the floor from a position approximately 90° to the left side, the rod is then swept in a circular path parallel to the ground to cover an angle of approximately 220°. The sweep continues vertically upwards along a straight line until the microphone is 0,5 m from the ceiling, after which another circular sweep covers approximately 220° in the opposite direction, before descending to the starting point along a vertical straight line. For a left-handed operator, the directions are reversed.

During the circular sections of the path, the operator shall aim to achieve a constant angular speed. The maximum angular speed shall be approximately 20° per second, with a maximum speed of approximately 0,25 m/s over the straight sections of the path.

### 7.2.3.5 Three semicircles

The path comprising three semicircles is indicated in [Figure 1](#). The operator shall stand holding the microphone or sound level metre with outstretched arm, and trace out three semicircles with approximately 45° to 60° separations. The plane of each semi-circle shall not lie in any plane that is less than 10° from any room surface (wall, floor or ceiling). If required, the knees can be bent to reduce the overall height of the microphone; this should be done when the path is repeated at another position in the room.

For each of the three semicircles, the operator shall aim to achieve a constant angular speed. The maximum angular speed shall be approximately 20° per second.

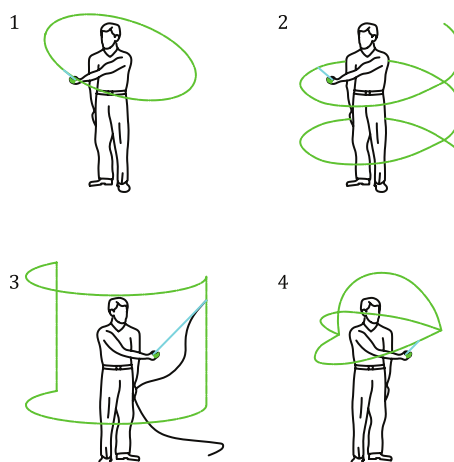
**Key**

- 1 circle
- 2 helix
- 3 cylindrical-type
- 4 three semicircles

**Figure 1 — Manual-scanning paths****7.2.4 Minimum distances for microphone positions**

For the default procedure, the following separation distances are minimum values and shall be exceeded where possible:

- a) 0,7 m between fixed microphone positions;
- b) 0,5 m between any microphone position and the room boundaries;
- c) 1,0 m between any microphone position and the loudspeaker when measuring reverberation times.

**7.2.5 Averaging times****7.2.5.1 Fixed microphone positions**

The averaging time at each individual microphone position shall be at least 6 s in the frequency range of 100 Hz to 400 Hz. For 500 Hz to 5 000 Hz, it is permissible to decrease the time to not less than 4 s. For 50 Hz to 80 Hz, the averaging time at each individual microphone position shall be at least 15 s.

**7.2.5.2 Mechanized continuously-moving microphone**

The averaging time shall cover a whole number of complete traverses and shall be at least 30 s for 100 Hz to 5 000 Hz, and at least 60 s for 50 Hz to 80 Hz.

**7.2.5.3 Manually-scanned microphone**

The averaging time shall cover a whole number of complete paths and shall be at least 30 s for 100 Hz to 5 000 Hz, and at least 60 s for 50 Hz to 80 Hz.

## 7.2.6 Calculation of energy-average sound pressure levels

### 7.2.6.1 Fixed microphone positions

The energy-average sound pressure level in the receiving room is determined using Formula (1).

$$L_2 = 10 \lg \left( \frac{p_1^2 + p_2^2 + \dots + p_n^2}{np_0^2} \right) \quad (1)$$

where

$p_1^2, p_2^2, \dots, p_n^2$  are the mean-square sound pressures at  $n$  different microphone positions in the room;

$p_0$  is the reference sound pressure and is equal to 20  $\mu\text{Pa}$ .

In practice, the sound pressure levels are usually measured and the energy-average sound pressure level shall be determined using Formula (2).

$$L_2 = 10 \lg \left( \frac{1}{n} \sum_{i=1}^n 10^{L_{p,i}/10} \right) \quad (2)$$

where

$L_{p,1}, L_{p,2}, \dots, L_{p,n}$  are the sound pressure levels at  $n$  different microphone positions in the room.

### 7.2.6.2 Mechanized continuously-moving microphone and manually-scanned microphone

The energy-average sound pressure level in the receiving room is determined using Formula (3).

$$L_2 = 10 \lg \left( \frac{\frac{1}{T_m} \int_0^{T_m} p^2(t) dt}{p_0^2} \right) \quad (3)$$

where

$p$  is the sound pressure, in Pascals;

$T_m$  is the averaging time, in seconds.

When more than one traverse or scan is carried out in the same room, the energy-average sound pressure level in that room is determined using Formula (4).

$$L_2 = 10 \lg \left( \frac{10^{L_{p,1}/10} + 10^{L_{p,2}/10} + \dots + 10^{L_{p,n}/10}}{n} \right) \quad (4)$$

where

$L_{p,1}, L_{p,2}, \dots, L_{p,n}$  are energy-average sound pressure levels from  $n$  different traverses/scans in the room.

## 7.3 Low-frequency procedure (element or global loudspeaker methods)

### 7.3.1 General

For the element and global loudspeaker methods, the low-frequency procedure shall be used for the 50 Hz, 63 Hz, and 80 Hz one-third octave bands in the room when its volume is smaller than 25 m<sup>3</sup> (calculated to the nearest cubic metre). Sound pressure level measurements are taken close to the corners of the room to identify the corner with the highest level in each band. This is carried out in the room (a) with the loudspeaker in operation to determine the corner sound pressure level and (b) when the loudspeaker is switched off to determine the background noise level.

### 7.3.2 Microphone positions

For the low-frequency procedure, a fixed microphone shall be positioned in room corners at a distance of 0,3 m to 0,4 m from each room boundary that forms the corner (see example in [Figure 2](#)).

NOTE The distance from each boundary that forms the corner does not have to be identical. For example, it could be positioned at a distance of 0,3 m from one boundary, 0,35 m from another boundary, and 0,4 m from the remaining boundary.

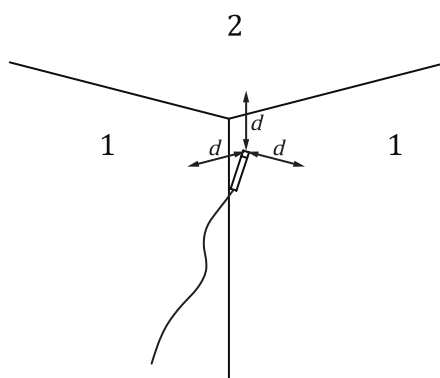

#### Key

- 1 wall
- 2 ceiling

NOTE This is an illustrative example of only one possible corner position in a room.

**Figure 2 — Example of a corner microphone position where the distance,  $d$ , shall be between 0,3 m to 0,4 m.**

A minimum of four corners shall be measured using a fixed or manually-held microphone. Two corners should be at ground level and two corners should be at ceiling level. These corners can or cannot be near the façade wall. Corners shall be used which are formed by three intersecting surfaces (such as walls, doors, windows, floor, or ceiling) each having an area of at least 0,5 m<sup>2</sup>, that are perpendicular to each other, with no objects such as furniture within 0,5 m of the corner. Where this is not possible, corners can be used where the three intersecting surfaces have angles between pairs of the surfaces between 45° and 135°, and/or where there are objects close to the three intersecting surfaces, and/or where an object such as a cupboard forms one of the intersecting surfaces.

For the 50 Hz, 63 Hz, and 80 Hz one-third octave bands, calculate the low-frequency energy average sound pressure level for the receiving room according to [7.3.4](#).

### 7.3.3 Averaging time

For the low-frequency procedure, the averaging time at each individual microphone position shall be at least 15 s.

### 7.3.4 Calculation of low-frequency energy-average sound pressure levels

With the loudspeaker operating, determine the highest sound pressure level from the set of measured corners for each of the 50 Hz, 63 Hz, and 80 Hz bands which is denoted as  $L_{2,Corner}$ .

NOTE For each of the 50 Hz, 63 Hz, and 80 Hz bands, the values for  $L_{2,Corner}$  can be associated with different corners in the room.

The low-frequency energy-average sound pressure level in the 50 Hz, 63 Hz, and 80 Hz bands is calculated by combining  $L_2$  from the default procedure and  $L_{2,Corner}$  from the low-frequency procedure using Formula (5).

$$L_{2,LF} = 10 \lg \left[ \frac{10^{0,1L_{2,Corner}} + (2 \cdot 10^{0,1L_2})}{3} \right] \quad (5)$$

## 7.4 Background noise (default and low-frequency procedure)

### 7.4.1 General

Measurements of background noise levels shall be made to ensure that the signal level in the receiving room is not affected by the background noise and to allow a correction as described in 7.4.2. Extraneous sound, such as noise from outside the test room, electrical noise in the receiving system, mechanical devices used for the continuously-moving microphone, and operators inside the test room all contribute to the background noise level.

It is recommended to check that the sound level metre does not introduce spurious signals when pressing buttons which start, pause or stop the measurement.

Operators are a potential source of background noise when using (a) fixed microphone positions where the operator remains inside the receiving room, (b) manually-held microphones, or (c) manually-scanned microphones. Self-generated noise from the operator can result from sources such as clothing, shoes, or arm/knee joints. For (a), (b), and (c), the operator shall use at least one of the following three methods to try and identify self-generated noise in the receiving room: (1) the time history of the A-weighted sound pressure level (fast time weighting) to look for unusual transient events, (2) the difference between the maximum sound pressure level with fast time weighting and the equivalent continuous sound pressure level in frequency bands to indicate unusual transient events, and (3) their own hearing, but only when hearing protection is not required and not used. Using one or more of these methods, the operator shall ensure that self-generated noise due to their movement and activity during the sound pressure level measurement of the signal level is similar to that during the background noise measurements.

For manually-scanned microphones, the operator shall carry out the background noise measurement using the same type of manual-scanning path that is used for the signal level measurement.

For the low-frequency procedure, a background noise measurement shall be carried out in each corner that is used to calculate the corner sound pressure levels.

NOTE For each of the 50 Hz, 63 Hz, and 80 Hz bands, the values for  $L_{2,Corner}$  can be associated with different corners in the room; hence each band can require an individual correction to the signal level for background noise.

The minimum averaging times for the background noise measurement shall satisfy the requirements in 7.2.5 or 7.3.3. Using an averaging time that exactly equals these minimum time periods is only appropriate when the background noise is steady and continuous, otherwise longer averaging times shall be used.

To check the electrical noise in the receiving system, replace the microphone by a dummy microphone.



## 7.4.2 Correction to the signal level for background noise

For the default and the low-frequency procedures, the background noise level shall be at least 6 dB (and preferably more than 10 dB) below the level of signal and background noise combined at each frequency band. If the difference in levels is smaller than 10 dB but greater than 6 dB, calculate corrections to the energy-average sound pressure level and the corner sound pressure level using Formula (6).

$$L_2 = 10 \lg(10^{L_{sb}/10} - 10^{L_b/10}) \quad (6)$$

where

$L_2$  is the adjusted signal level, in decibels;

$L_{sb}$  is the level of signal and background noise combined, in decibels;

$L_b$  is the background noise level, in decibels.

The values for  $L_{sb}$  and  $L_b$  shall be reduced to one decimal place before use in Formula (6). This is done by taking the value in tenths of a dB closest to the reported values such that XX,XYZZZ... is rounded to XX,X if Y is less than 5 and to XX,X + 0,1 if Y is equal to or greater than 5.

If the difference in levels is less than or equal to 6 dB in any of the frequency bands, use the 1,3 dB correction. For each frequency band where this is the case for the default procedure and/or the low-frequency procedure, it shall be clearly indicated in the report that a 1,3 dB correction has been made and that the values are at the limit of the measurement.

## 8 Reverberation time measurements in the receiving room (default and low-frequency procedure)

### 8.1 General

This clause describes the default procedure that shall be used in the receiving room for all reverberation time measurements, and a low-frequency procedure that shall be used when the receiving room volume is smaller than 25 m<sup>3</sup> (calculated to the nearest cubic metre).

The reverberation times shall be measured using the interrupted noise method or the integrated impulse response method as described in ISO 3382-2 and ISO 18233. The engineering method is preferred although the precision method can be used.

Evaluation of the reverberation time from the decay curve shall start at 5 dB below the initial sound pressure level. The preferred evaluation range is 20 dB. The bottom of the evaluation range shall be at least 10 dB above the overall background noise level.

Any operator that was in the receiving room during the sound pressure level measurement shall also be in the receiving room for reverberation time measurements. The operator can be present in the room with the microphone fixed on a tripod, or with the operator using a manually-held microphone at a fixed position; in both cases the trunk of the operator's body shall remain at a distance at least an arm's length from the microphone. To determine the apparent sound reduction index, calculate the equivalent sound absorption area from the reverberation time using the formula in [3.17](#).

### 8.2 Generation of sound field

Use loudspeaker(s) at fixed positions that comply with the directivity requirements in [Annex C](#). Loudspeakers can be used simultaneously provided that they are of the same type and are driven at the same level by similar, but uncorrelated, signals.

For the default procedure, the sound generated in the room shall be steady and have a continuous spectrum over the frequency range considered. Parallel measurements over the required range of one-

third octave bands can be taken using a broadband noise signal. If filtering of the source signal is used for each frequency band under test, use a filter with a corresponding centre-band frequency with a bandwidth of at least one-third octave.

For the low-frequency procedure, the sound generated in the room shall be steady and have a continuous spectrum at least over the frequency range covered by the 63 Hz octave band.

### 8.3 Default procedure

The default procedure shall use the interrupted noise method described in 8.5 or the integrated impulse response method described in 8.6 for all one-third octave bands between 50 Hz and 5 000 Hz when the receiving room has a volume larger than or equal to 25 m<sup>3</sup> (calculated to the nearest cubic metre), and between 100 Hz and 5 000 Hz when the receiving room has a volume smaller than 25 m<sup>3</sup> (calculated to the nearest cubic metre).

### 8.4 Low-frequency procedure

The low-frequency procedure shall use the interrupted noise method described in 8.5 or the integrated impulse response method described in 8.6 when the receiving room volume is smaller than 25 m<sup>3</sup> (calculated to the nearest cubic metre). This procedure requires that the reverberation time is measured in the 63 Hz octave band instead of the 50 Hz, 63 Hz, and 80 Hz one-third octave bands and that this single measured value is used to represent the 50 Hz, 63 Hz, and 80 Hz bands in the calculation of  $R'_{45^\circ}$ ,  $D_{1s,2m,nT}$ , and  $D_{1s,2m,n}$ .

NOTE 1 In small room volumes, there are relatively few room modes that determine the decay curve in the 50 Hz, 63 Hz, and 80 Hz bands. Hence, the use of 20 dB or 30 dB evaluation ranges on the decay curves from one-third octave bands are prone to error because single-slope decay curves usually only occur when there are many modes in each frequency band. This issue can partly be resolved through use of the 63 Hz octave band filter.

NOTE 2 In timber or steel frame buildings with gypsum or timber board linings, the reverberation times in the 50 Hz, 63 Hz, and 80 Hz bands can be sufficiently short that the decay curve is affected by the decay time of the one-third octave band filters in the analyser. This can be avoided by using a 63 Hz octave band filter due to its wider bandwidth which allows the measurement of shorter reverberation times.

### 8.5 Interrupted noise method

For fixed or manually-held microphone positions, the minimum number of measurements required for each frequency band is six. At least one loudspeaker position shall be used with three fixed microphone positions and two measurements at each position, or six fixed microphone positions and one measurement at each position.

For a mechanized continuously-moving microphone, the minimum number of measurements required for each frequency band is six. At least one loudspeaker position shall be used with six measurements carried out along the microphone traverse.

### 8.6 Integrated impulse response method

For the integrated impulse response method, measurement of the reverberation time shall use fixed microphone positions.

Using an impulse source, the minimum number of measurements required for each frequency band is six. At least one source position and six fixed microphone positions shall be used.

The reverberation time shall be calculated by reverse-time integration of the squared impulse response.



## 9 Outdoor measurements using a loudspeaker as a sound source (default and low-frequency procedure)

### 9.1 General

Two methods are described, the element and the global loudspeaker method.

### 9.2 Generation of the sound field

The loudspeaker is placed in one or more positions outside the building at a distance,  $D$ , from the façade, with the angle of sound incidence equal to  $45^\circ \pm 5^\circ$  (see [Figure 3](#)).

The average sound pressure level is determined either directly on the test specimen (the element method) or 2 m in front of the façade (the global method), as well as in the receiving room in order to calculate the apparent sound reduction index,  $R'_{45^\circ}$ , or the level difference,  $D_{ls,2m}$ .

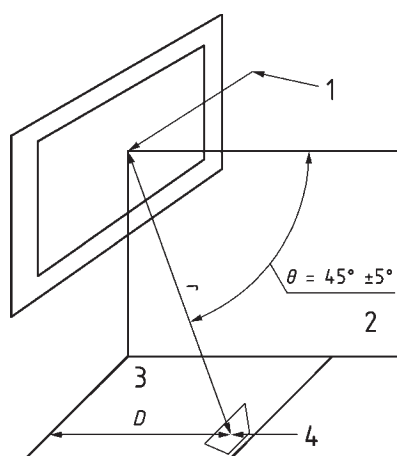

#### Key

- 1 normal to the façade
- 2 vertical plane
- 3 horizontal plane
- 4 loudspeaker

**Figure 3 — Geometry of the loudspeaker method**

### 9.3 Loudspeaker requirements

The directivity of the loudspeaker in the free field shall be such that the local differences in the sound pressure level in each frequency band of interest are less than 5 dB, measured on an imaginary surface of the same size and orientation as the test specimen. If the loudspeaker method is used for large test specimens, i.e. specimens where one dimension exceeds 5 m, differences up to 10 dB can be accepted but this shall be stated in the measurement report. Alternatively, a loudspeaker can be used that satisfies the directivity requirements in [Annex C](#).

The sound field generated by the loudspeaker shall be steady and have a continuous spectrum in the frequency range considered. The differences between the sound power levels in the one-third octave bands that define the octave bands shall not be greater than 6 dB in the 125 Hz octave band, 5 dB in the 250 Hz octave band and 4 dB in octave bands with higher centre frequencies.

In all relevant frequency bands, the sound power level of the sound source shall be high enough to give a sound pressure level in the receiving room that exceeds the background noise level by at least 6 dB.

## 9.4 Loudspeaker positions

Choose the position of the loudspeaker and the distance,  $D$ , to the façade so that the variation of the sound pressure level on the test specimen is minimised. Therefore, the loudspeaker should preferably be placed on the ground, or as high above the ground as is possible in practice. The distance,  $r$ , from the loudspeaker to the centre of the test specimen shall be at least 5 m ( $D > 3,5$  m) for the element loudspeaker method, and at least 7 m ( $D > 5$  m) for the global loudspeaker method. The angle of the sound incidence shall be  $45^\circ \pm 5^\circ$  (see [Figure 3](#)).

## 9.5 Element loudspeaker method

### 9.5.1 Outdoor sound pressure level measurements on the test surface

Determine the average outdoor sound pressure level on the test surface,  $L_{1,s}$ , by carrying out measurements with the microphone fastened directly on the actual test specimen with (a) its axis parallel to the plane of the façade and directed upwards or downwards or (b) its axis pointing in the direction normal to the test specimen. The distance from the test specimen to the centre of the microphone membrane shall be  $\leq 10$  mm if the axis of the microphone is parallel to the test surface and  $\leq 3$  mm if the axis is normal to the test surface.

If the microphone is fastened to the test specimen, the microphone shall be securely fixed so that its position does not change during the measurement.

NOTE 1 Strong, adhesive tape is usually practical for a temporary, but secure, fastening.

If simultaneous measurements are carried out indoors and outdoors, the microphone, cables, and fixing used outdoors on the test specimen shall not affect the sound transmitted by the test specimen.

The microphone shall use a hemispherical windscreen (see [Figure 4](#)).

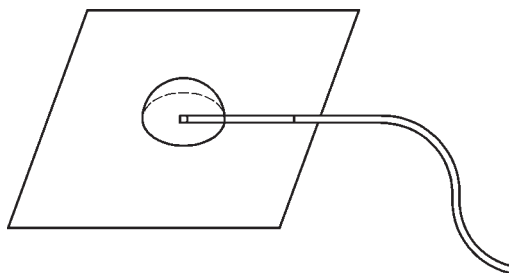

**Figure 4 — Flush-mounted microphone (axis parallel to the test surface) with hemispherical windscreen**

A minimum of three and a maximum of 10 fixed microphone positions shall be used depending on the variation in sound pressure level between the different positions. The positions shall not be in a regular grid, and each set of microphone positions shall be distributed evenly but asymmetrically over the measurement surface. It is recommended to begin with  $n$  microphone positions, where  $n = 3$ . If the difference in the sound pressure level between any two positions in a frequency band is more than  $n$  dB, increase the number of microphone positions up to a maximum of 10. If the test specimen is mounted in a recess of the façade, the number of microphone positions shall be 10. If the difference in the sound pressure levels is greater than 10 dB, this shall be stated in the measurement report.

NOTE 2 The difference in the sound pressure levels is affected by the height of the microphone, height of the loudspeaker, recesses, balconies, and the position of the test specimen on the façade.

The average outdoor sound pressure level on the test surface shall be determined using Formula (7).

$$L_{1,s} = 10 \lg \left( \frac{1}{n} \sum_{i=1}^n 10^{L_i/10} \right) \quad (7)$$

where

$L_1, L_2, \dots, L_n$  are the sound pressure levels at  $n$  different microphone positions on the test surface.

## 9.6 Global loudspeaker method

### 9.6.1 Outdoor sound pressure level measurements near the façade

Determine the average outdoor sound pressure level at a distance 2 m in front of the façade,  $L_{1,2m}$ , either with the microphone on the outside of the façade, in the middle of the façade surface at a distance  $(2 \pm 0,2)$  m from the plane of the façade, or 1 m from a balustrade or other similar protrusion.

The height of the microphone shall be 1,5 m above the floor of the receiving room.

If the main part of the façade is a sloping construction such as a roof, choose a position not nearer to the roof than the projected part of the vertical part of the façade. If the room considered has more than one outside wall or is very large, see [9.6.2](#).

NOTE Systematic errors will occur at low frequencies due to interference effects.

### 9.6.2 Large rooms or façades comprising more than one outside wall

If the room is very large or if it has more than one outside wall, it is normally not possible to measure with only one source position. In such cases, use several source positions, each in full compliance with [9.4](#). The number of positions is given by the directivity of the loudspeaker and the size of the façade (see [9.3](#)).

### 9.6.3 Calculation of measurement results

Calculate the level difference,  $D_{1s,2m}$ , as described in the formula in [3.14](#). If more than one loudspeaker position is used, calculate the level difference for each position and average them according to Formula (8).

$$D_{1s,2m} = -10 \lg \left( \frac{1}{n} \sum_{i=1}^n 10^{-D_i/10} \right) \quad (8)$$

where

$n$  is the number of source positions;

$D_i$  is the level difference for each source-receiver combination.

## 10 Outdoor measurements using road traffic as a sound source (default procedure)

### 10.1 General

Two methods are described, the element and the global road traffic method. Using road traffic as a source results in sound that is incident on the test specimen from different directions with varying intensity. The corresponding methods for railway and aircraft traffic noise are described in [Annex E](#).

The element road traffic method will yield an estimate of the apparent sound reduction index which, under specified circumstances, can be compared with the corresponding sound reduction index obtained in a laboratory.

NOTE Due to the existing background noise, this method is usually limited to measuring elements or façades with  $R'_W < 40$  dB.

The global road traffic method will quantify the airborne sound insulation of a whole façade or a whole building in a specified situation. This result cannot be compared with a sound reduction index obtained in a laboratory.

### 10.2 Test requirements

The averaging time shall include at least 50 vehicle pass-bys within the minimum times required in [7.2.5](#).

Road traffic tends to be a variable sound source and therefore the indoor and outdoor sound pressure levels shall be measured simultaneously.

During the measurements, the background noise in the receiving room shall be at least 10 dB below the measured equivalent sound pressure level.

NOTE Corrections for background noise according to [7.4](#) cannot normally be carried out due to the variation in level from road traffic.

### 10.3 Element road traffic method

#### 10.3.1 General

The element road traffic method shall be used where the purpose of the measurement is to compare the results with laboratory measurements or to obtain results which are representative of a façade element, but the element loudspeaker method cannot be used for practical reasons.

Under some circumstances, it can be necessary to apply the element road traffic method although the requirements are not fully satisfied; however this shall be stated in the measurement report.

#### 10.3.2 Requirements on road traffic and façade geometry

The measurement situation shall fulfil the following requirements.

- a) The traffic shall flow approximately along a straight line within an angle of sight within  $\pm 60^\circ$  from the façade; within this angle, deviations from a straight line are allowed within  $\pm 15^\circ$  with the tangent to the traffic line at the intersection of the traffic line and the normal from the façade on the traffic line (see [Figure 5](#)).
- b) The angle of elevation, observed from the point of least distance between the façade and the line of traffic, shall be less than  $\pm 40^\circ$ .
- c) Free view of the whole façade shall be possible from the whole width of the traffic flow.
- d) The minimum horizontal distance between the traffic line and the façade shall be at least three times the width of the façade to be tested, or 25 m, whichever is the largest.

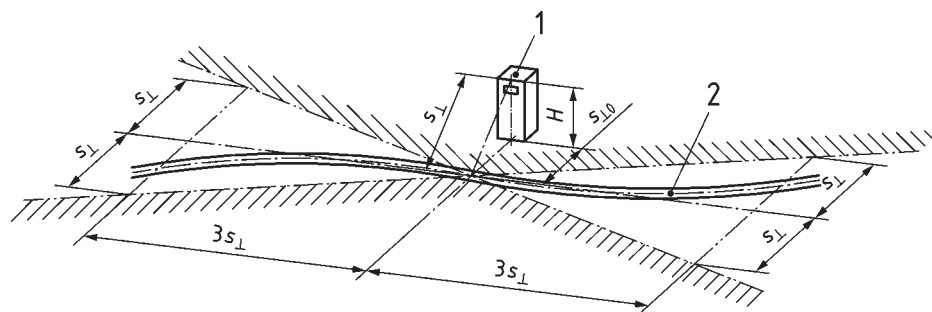
**Key**

- 1 receiving point  
2 traffic line

**NOTE**

$s_{\perp}$  is the distance between the receiving point and the traffic line;

$s_0$  is the horizontal distance between the receiving point and the traffic line;

$H$  is the height difference between the receiving point and the traffic line.

**Figure 5 — Conditions with long straight lines of traffic**

### 10.3.3 Outdoor sound pressure level measurements on the test surface

Determine the average outdoor sound pressure level on the test surface using Formula (8) with microphone positions on the outside of the test specimen as described in 9.5.1.

If the façade is flat without recesses or balconies, use three microphone positions distributed evenly but asymmetrically over the measurement surface. If the façade has large recesses or balconies, use five microphone positions.

If fixed indoor microphone positions are used, it is permitted to use one indoor position for each outdoor microphone position.

## 10.4 Global road traffic method

### 10.4.1 Outdoor sound pressure level measurements at a distance of 2 m in front of the façade

Determine the average outdoor sound pressure level at a distance 2 m in front of the façade,  $L_{1,2m}$ , with the microphone in front of the middle of the façade. However, if there is a balustrade or similar protrusion then the microphone should be 1 m in front of this balustrade or protrusion.

The height of the microphone shall be 1,5 m above the floor of the receiving room.

If the main part of the façade is a sloping construction such as a roof, choose a position not nearer to the roof than the projected part of the vertical part of the façade. If the room considered is very large or if it has more than one outside wall, position the microphone on each façade or on several points in front of the façade.

**NOTE** Systematic errors will occur at low frequencies due to interference effects.

### 10.4.2 Calculation of measurement results

If several microphone positions are used, calculate the level difference for each position and average them according to Formula (9).

$$D_{tr,2m} = -10 \lg \left( \frac{1}{n} \sum_{i=1}^n 10^{-D_i/10} \right) \quad (9)$$

where

$n$  is the number of microphone positions on the outdoor surface;

$D_i$  is the level difference for each source-receiver combination.

## 11 Conversion to octave bands

If the apparent sound reduction index is needed in octave bands, values shall be calculated from the three one-third octave band values in each octave band according to Formulae (10) to (13).

The one-third octave band values shall be reduced to one decimal place before use in Formulae (10) to (13). This is done by taking the value in tenths of a dB closest to the reported values such that XX,XYZZZ... is rounded to XX,X if Y is less than 5 and to XX,X + 0,1 if Y is equal to or greater than 5. Present the final results with no higher precision than to the nearest 0,1 dB.

$$R'_{45^\circ,oct} = -10 \lg \left( \frac{\sum_{n=1}^3 10^{-R'_{45^\circ,1/3oct,n}/10}}{3} \right) \quad (10)$$

$$R'_{tr,oct} = -10 \lg \left( \frac{\sum_{n=1}^3 10^{-R'_{tr,1/3oct,n}/10}}{3} \right) \quad (11)$$

$$R'_{rt,oct} = -10 \lg \left( \frac{\sum_{n=1}^3 10^{-R'_{rt,1/3oct,n}/10}}{3} \right) \quad (12)$$

$$R'_{at,oct} = -10 \lg \left( \frac{\sum_{n=1}^3 10^{-R'_{at,1/3oct,n}/10}}{3} \right) \quad (13)$$

If the standardized or normalized (including single event) level differences are needed in octave bands, outdoor and indoor sound pressure levels shall be calculated from the three one-third octave band values in each octave band according to Formula (14) or Formula (15) for the outdoor sound pressure level and Formula (16) or Formula (17) for the sound pressure level in the room. The format of Formulae (14) to (21) are written this way to make a clear link back to the definitions in 3; note that this calculation does not require additional measurements of reverberation times in octave bands.

The one-third octave band values shall be reduced to one decimal place before use in Formulae (14), (15), (16), and (17). This is done by taking the value in tenths of a dB closest to the reported values such that XX,XYZZZ... is rounded to XX,X if Y is less than 5 and to XX,X + 0,1 if Y is equal to or greater than 5. Present the final results with no higher precision than to the nearest 0,1 dB.

**NOTE** It is not appropriate to calculate the octave band values from the standardized level difference when the outdoor sound pressure level is  $L_{1,2m}$ . This is due to interference effects from the combination of the direct and reflected sound paths that determine the sound pressure level at a distance of 2 m in front of the façade.

$$L_{1,2m,oct} = 10 \lg \left( \sum_{n=1}^3 10^{L_{1,2m,1/3oct,n}/10} \right) \quad (14)$$

$$L_{E1,2m,oct} = 10 \lg \left( \sum_{n=1}^3 10^{L_{E1,2m,1/3oct,n}/10} \right) \quad (15)$$

$$L_{2,oct} - 10 \lg \left( \frac{T_{oct}}{T_0} \right) = 10 \lg \left( \sum_{n=1}^3 10^{(L_{2,1/3oct,n} - 10 \lg(T_{1/3oct,n}/T_0))/10} \right) \quad (16)$$

$$L_{E2,oct} - 10 \lg \left( \frac{T_{oct}}{T_0} \right) = 10 \lg \left( \sum_{n=1}^3 10^{(L_{E2,1/3oct,n} - 10 \lg(T_{1/3oct,n}/T_0))/10} \right) \quad (17)$$

The standardized level difference is calculated using Formula (18)

$$D_{2m,nT,oct} = L_{1,2m,oct} - \left( L_{2,oct} - 10 \lg \left( \frac{T_{oct}}{T_0} \right) \right) \quad (18)$$

and the normalized level difference is calculated using Formula (19)

$$D_{2m,n,oct} = L_{1,2m,oct} - \left( L_{2,oct} + 10 \lg \left( \frac{A_{oct}}{A_0} \right) \right) \quad (19)$$

and the standardized single event level difference is calculated using Formula (20)

$$D_{E,2m,nT,oct} = L_{E1,2m,oct} - \left( L_{E2,oct} - 10 \lg \left( \frac{T_{oct}}{T_0} \right) \right) \quad (20)$$

and the normalized single event level difference is calculated using Formula (21)

$$D_{E,2m,n,oct} = L_{E1,2m,oct} - \left( L_{E2,oct} + 10 \lg \left( \frac{A_{oct}}{A_0} \right) \right) \quad (21)$$

where  $T_{oct}$  is the reverberation time determined from the arithmetic average of the one-third octave band values that form the octave band, or measured using octave band filters and  $A_{oct}$  is calculated using  $T_{oct}$  as described in the formula in [3.17](#).

NOTE The two methods of calculating  $T_{oct}$  can give different values.

## 12 Expression of results

For the statement of the airborne sound insulation of the test element, the measurement results,  $R'_{45}$ ,  $R'_{tr,s}$ ,  $R'_{rt,s}$ ,  $R'_{at,s}$ ,  $D_{ls,2m,nT}$ ,  $D_{ls,2m,n}$ ,  $D_{tr,2m,nT}$ ,  $D_{tr,2m,n}$ ,  $D_{rt,2m,nT}$ ,  $D_{rt,2m,n}$ ,  $D_{at,2m,nT}$ , or  $D_{at,2m,n}$ , shall be given in decibels at all measurement frequencies in one-third octave bands to one decimal place, both in tabular form and in the form of a curve.

Graphs in the test report shall show the value in decibels plotted against frequency on a logarithmic scale; the following dimensions shall be used:

- a) 5 mm for a one-third octave band;
- b) 20 mm for 10 dB.

The preferred format for the graphs is given [Annex F](#) with the accompanying text stating all relevant information concerning the test site, construction, procedure and results.



### 13 Uncertainty

The uncertainty of the measurement result shall be determined in accordance with the method given in ISO 12999-1.

### 14 Test report

The test report shall include at least the following information:

- a) a reference to this International Standard, i.e. ISO 16283-3, the year of publication and any amendments;
- b) name of the organization that has performed the measurements;
- c) name and address of the organization or person who commissioned the test (client);
- d) date of the test;
- e) description and identification of the building construction (address or other unambiguous identifier) and test arrangement (including any temporary modification of the room contents for the test, e.g. the introduction of diffusers (see [Clause 6](#)));
- f) volumes of the receiving room (calculated to the nearest cubic metre) and the area of any separating element  $S$  (see [Annex A](#));
- g) standardized level difference or the apparent sound reduction index as a function of frequency;
- h) brief description of the test procedure, brief details of the equipment, and indicate whether the low-frequency procedure was used for sound pressure level and reverberation time in the 50 Hz, 63 Hz and 80 Hz one-third octave bands;
- i) indications of results which are to be taken as limits of measurement. For example, they shall be given as  $D_{1s,2m,nT}$  or  $R'_{45^\circ} \geq \dots$ dB. This shall be applied if the sound pressure level in any band is not measurable on account of background noise (see [7.4](#));

For the evaluation of single-number ratings from the curves, see ISO 717-1. It shall be clearly stated that the evaluation has been based on a result obtained by a field method. The test report should also include the uncertainty in the single-number rating.

The recommended form for the expression of results is given in [Annex F](#).



## **Annex A**

### **(normative)**

### **Determination of area, $S$**

When determining the sound reduction index for a façade element, e.g. for a window or a door, the area,  $S$ , is equal to the area of the free opening in the wall where the window or the door is mounted. The area,  $S$ , that is used shall be given in the measurement report.

When determining the sound reduction index for the whole façade of a receiving room, the area,  $S$ , is equal to the area of the part of the façade which can be seen from the receiving room.

**Annex B**  
(normative)

**Control of sound transmission through the wall surrounding the test specimen**

Cover the test specimen and only the test specimen on the inside with 10 cm thick mineral wool covered with at least two sheets of 12,5 mm thick plasterboard. If the measured sound insulation with this shielding shows an improvement which is less than 6 dB across the whole frequency range, or parts of it, the sound transmission through the surrounding wall and/or the sound transmission via flanking building elements is unacceptably high. The implication is that accurate comparisons with laboratory measurements cannot be made at frequencies where the improvement is less than 6 dB.

## Annex C (normative)

### Requirements for loudspeakers

#### C.1 General

A loudspeaker shall be a closed cabinet containing one or more individual speaker units. All speaker units in the same cabinet shall radiate in phase.

The directivity of loudspeakers shall have approximately uniform, omnidirectional radiation. The qualification procedure for loudspeaker directivity that is described in [C.2](#) shall be used to confirm that the loudspeaker is suitable for measurements.

**NOTE** In choosing a suitable loudspeaker, it is common to find that loudspeakers mounted on the surfaces of a polyhedron, preferably a dodecahedron, will give uniform, omnidirectional radiation. For the measurement of reverberation time, this is also achievable with a hemisphere polyhedron loudspeaker that is mounted directly on the floor.

#### C.2 Qualification procedure for directivity

To test the directional radiation of a loudspeaker, measure the sound pressure levels around the source at a distance of 1,5 m from the centre of the loudspeaker in a free-field environment. The loudspeaker should be rotated using a turntable or by taking discrete measurements at 5° intervals. The loudspeaker shall be driven with a broadband noise signal, and measurements made in one-third octave bands.

Measure  $L_{360^\circ}$  which is the energy-average level for the complete arc of 360°. Measure  $L_{30,i}$  values for each angle step  $i$  (typically chosen as 1° or 5° intervals) which correspond to the energy-average value over an arc of 30° that is centred around the angle step (i.e. ±15°). The directivity indices shall be calculated using Formula (C.1).

$$DI_i = L_{360^\circ} - L_{30,i} \quad (\text{C.1})$$

For one-third octave bands, the loudspeaker(s) can be considered to have uniform omnidirectional radiation if the  $DI$  values are within ± 2dB for the frequency range from 100 Hz to 630 Hz, ± 5 dB for 800 Hz and ± 8 dB for the frequency range from 1 000 Hz to 5 000 Hz.

Carry out the test in different planes to ensure inclusion of the “worst case” condition. For a polyhedron source, testing in one plane is sufficient.

This qualification procedure shall be carried out at intervals not exceeding two years to ensure conformance.

## **Annex D** **(informative)**

### **Examples of verification of test requirements**

#### **D.1 Evaluation of a test specimen**

To find out if a test specimen is identical to the one tested in the laboratory, the following checks may be carried out:

- type of window constructions;
- thickness and type of glass;
- number of panes;
- type of gas fill in sealed glazing units;
- number and type of seals;
- the existence of a dust deal (in windows between the coupled sashes);
- type and material of the frame.

#### **D.2 Verification of mounting**

To ascertain that the mounting is carried out according to the manufacturer's instructions, one or more of the following tests may be carried out:

- visual examination;
- total or partial dismounting;
- acoustical check, e.g. by testing the test specimen after the space between the frame and the wall has been taped over. If there is a difference in the sound insulation, there is a leak.

## **Annex E** (informative)

### **Measurements with aircraft and railway traffic noise (default procedure)**

#### **E.1 General**

Aircraft traffic noise in the neighbourhood of airports is transmitted into buildings through a number of different propagation paths during each aircraft operation. During each operation, the frequency spectrum of the sound that is incident upon the building often varies. For this reason, measurements of sound insulation against aircraft traffic are based on time-integrated descriptors.

Sound insulation against railway traffic is considered alongside aircraft traffic as it has a similar time pattern.

#### **E.2 Methods**

Two methods are described, the element and the global traffic method.

The element method yields an estimate of the apparent sound reduction index which, under specified circumstances, can be used to estimate the sound insulation of one particular element of a building. However the measurement precision is not yet known.

The global loudspeaker method quantifies the airborne sound insulation of a whole façade or a whole building relative to a position 2 m in front of the façade but this result does not allow direct comparison with laboratory measurements.

#### **E.3 Instrumentation**

See [Clause 4](#).

#### **E.4 Measurements**

##### **E.4.1 General**

Aircraft or railway noise is used as the sound source and sound pressure levels are measured simultaneously outdoors and indoors.

##### **E.4.2 Test requirements**

The outdoor and indoor sound pressure levels from the traffic shall be sufficiently high to ensure that the measurements are unaffected by background noise within the frequency range of interest.

##### **E.4.3 Frequency range**

See [Clause 5](#).

## E.4.4 Element method

### E.4.4.1 General

If the purpose of the measurement is to compare the results with laboratory measurements or to obtain results which are representative of a façade element, the procedure given in 9.5 should be used. If this procedure is not possible for practical reasons, use the element method for air or railway traffic described here.

Under some circumstances, it may be necessary to apply the element method although the requirements are not fully satisfied but this shall be stated in the measurement report.

### E.4.4.2 Outdoor measurement of single event levels

Place the microphone on the outer surface of the test specimen as described in 9.5.1. If the façade is flat without recesses or balconies, use three microphone positions asymmetrically distributed over the measurement surface. If the façade has large recesses or balconies, use five microphone positions.

Measure the single event level for at least five noise events. The microphone may be moved between the noise events. Denote the measured single event level for event  $i$  as  $L_{E1,s,i}$ , and calculate the average single event level using Formula (E.1).

$$L_{E1,s} = 10 \lg \left( \frac{1}{n} \sum_{i=1}^n 10^{L_{E1,s,i}/10} \right) \quad (\text{E.1})$$

### E.4.4.3 Indoor measurement of single event levels

Measure the single event level for the same events as for the outdoor measurements. If fixed microphone positions are used, it is permitted to use one position for each microphone position on the outside. Denote the measured single event level for event  $i$  as  $L_{E2,i}$ , and calculate the average single event level using Formula (E.2).

$$L_{E2} = 10 \lg \left( \frac{1}{n} \sum_{i=1}^n 10^{L_{E2,i}/10} \right) \quad (\text{E.2})$$

Follow the requirements in Clause 7 with the exception that when using a mechanized continuously-moving microphone the duration of the traverse period should be no longer than the duration of the event and not more than 15 s.

### E.4.4.4 Reverberation time measurements in the receiving room

See Clause 8.

### E.4.4.5 Calculation of measurement results

Calculate the apparent sound reduction index,  $R'_{at,s}$  or  $R'_{rt,s}$ , and the weighted apparent sound reduction index  $R'_{at,s,w}$  or  $R'_{rt,s,w}$  according to ISO 717-1. If several noise events were used, calculate the apparent sound reduction index for each position and average them according to Formula (E.3).

$$R'_s = -10 \lg \left( \frac{1}{n} \sum_{i=1}^n 10^{-R'_{s,i}/10} \right) \quad (\text{E.3})$$

where

$n$  is the number of events;

$R'_{s,i}$  is the apparent sound reduction index for event  $i$ .

#### E.4.4.6 Forms for recording results

See [Annex F](#).

### E.4.5 Global method

#### E.4.5.1 Outdoor measurement of single event levels

Measure the outdoor single event level at a distance 2 m in front of the façade,  $L_{1,2m}$ , either with the microphone on the outside of the façade, in the middle of the façade surface at a distance  $(2 \pm 0,2)$  m from the plane of the façade, or 1 m from a balustrade or other similar protrusion.

The height of the microphone shall be 1,5 m above the floor of the receiving room.

If the main part of the façade is a sloping construction such as a roof, choose a position not nearer to the roof than the projected part of the vertical part of the façade. If the room considered has more than one outside wall or is very large, see [10.4.1](#).

NOTE Systematic errors will occur at low frequencies due to interference effects.

Denote the measured single event level for event  $i$  as  $L_{E1,2m,i}$ , and calculate the average single event level,  $L_{E1,2m}$ , using Formula (E.4).

$$L_{E1,2m} = 10 \lg \left( \frac{1}{n} \sum_{i=1}^n 10^{L_{E1,2m,i}/10} \right) \quad (\text{E.4})$$

#### E.4.5.2 Indoor measurement of single event levels

Measure the single event level for the same events as for the outdoor measurements. If fixed indoor microphone positions are used, it is permitted to use one indoor position for each event.

For at least five events, measure the single event level for event  $i$  as  $L_{E2,i}$  and calculate the average single event level,  $L_{E2}$ , using Formula (E.5).

$$L_{E2} = 10 \lg \left( \frac{1}{n} \sum_{i=1}^n 10^{L_{E2,i}/10} \right) \quad (\text{E.5})$$

Follow the requirements in [Clause 7](#) with the exception that when using a mechanized continuously-moving microphone the duration of the traverse period should be no longer than the duration of the event and not more than 15 s.

#### E.4.5.3 Reverberation time measurements in the receiving room

See [Clause 8](#).

#### E.4.5.4 Calculation of measurement results

Calculate the standardized single event level difference,  $D_{E,2m,nT}$  or the normalized single event level difference,  $D_{E,2m,n}$ , and the weighted standardized single event level difference,  $D_{E,2m,nT,w}$  or the weighted normalized single event level difference,  $D_{E,2m,n,w}$ , according to ISO 717-1. If several noise

events were used, calculate the standardized or normalized single event level difference for each position and average them according to Formula (E.6)

$$D_{E,2m} = -10 \lg \left( \frac{1}{n} \sum_{i=1}^n 10^{-D_{E,2m,i}/10} \right) \quad (\text{E.6})$$

where

$n$  is the number of events;

$D_{E,2m,i}$  is the level difference for event  $i$ .

#### E.4.5.5 Forms for recording results

See [Annex F](#).



## **Annex F** (informative)

### **Forms for recording results**

This Annex gives examples of forms for the expression of results for the field measurements of façade sound insulation for one-third octave bands. The curves of reference values shown in the forms are taken from ISO 717-1. The latest version of that standard is applied. The reference curves should be supplemented or at least replaced by the shifted reference curves according to the procedure described in ISO 717-1. An example is given for  $R'_{45^\circ}$ .

Apparent sound reduction index measured in accordance with ISO 16283-3																																													
Field measurements of façade sound insulation																																													
Client:	Date of test:																																												
Description and identification of the building construction and test arrangement, direction of measurement etc.																																													
Area of common partition:	m <sup>2</sup>																																												
Receiving room volume	m <sup>3</sup>																																												
----- frequency range according to the ———— curve of reference values (ISO 717-1)																																													
<table border="1" style="width: 100%; border-collapse: collapse; text-align: center;"> <thead> <tr> <th style="width: 50%;">Frequency f Hz</th> <th style="width: 50%;">R'<sub>45°</sub> one-third octave dB</th> </tr> </thead> <tbody> <tr><td>50</td><td></td></tr> <tr><td>63</td><td></td></tr> <tr><td>80</td><td></td></tr> <tr><td>100</td><td></td></tr> <tr><td>125</td><td></td></tr> <tr><td>160</td><td></td></tr> <tr><td>200</td><td></td></tr> <tr><td>250</td><td></td></tr> <tr><td>315</td><td></td></tr> <tr><td>400</td><td></td></tr> <tr><td>500</td><td></td></tr> <tr><td>630</td><td></td></tr> <tr><td>800</td><td></td></tr> <tr><td>1 000</td><td></td></tr> <tr><td>1 250</td><td></td></tr> <tr><td>1 600</td><td></td></tr> <tr><td>2 000</td><td></td></tr> <tr><td>2 500</td><td></td></tr> <tr><td>3 150</td><td></td></tr> <tr><td>4 000</td><td></td></tr> <tr><td>5 000</td><td></td></tr> </tbody> </table>	Frequency f Hz	R' <sub>45°</sub> one-third octave dB	50		63		80		100		125		160		200		250		315		400		500		630		800		1 000		1 250		1 600		2 000		2 500		3 150		4 000		5 000		
Frequency f Hz	R' <sub>45°</sub> one-third octave dB																																												
50																																													
63																																													
80																																													
100																																													
125																																													
160																																													
200																																													
250																																													
315																																													
400																																													
500																																													
630																																													
800																																													
1 000																																													
1 250																																													
1 600																																													
2 000																																													
2 500																																													
3 150																																													
4 000																																													
5 000																																													
Rating in accordance with ISO 717-1: R' <sub>45°;W</sub> (C; C <sub>tr</sub> ) = ( , ) dB																																													
C <sub>50-3150</sub> = dB;      C <sub>50-5000</sub> = dB;      C <sub>100-5000</sub> = dB																																													
Evaluation based on field measurement using results obtained by an engineering method:																																													
C <sub>tr,50-3150</sub> = dB;      C <sub>tr,50-5000</sub> = dB;      C <sub>tr,100-5000</sub> = dB																																													
No. of test report:	Name of test institute:																																												
Date:	Signature:																																												

Figure F.1 — Example of a form for the expression of results

## Bibliography

- [1] IEC 61672-2, *Electroacoustics — Sound level meters — Part 2: Pattern evaluation tests*
- [2] IEC 61672-3, *Electroacoustics — Sound level meters — Part 3: Periodic tests*
- [3] OIML Recommendations R 58, *Sound level meters*, 1998<sup>1)</sup>
- [4] OIML Recommendations R 88, *Integrating-averaging sound level meters*, 1998<sup>1)</sup>
- [5] SIMMONS C. Measurement of sound pressure levels at low frequencies in rooms. Comparison of available methods and standards with respect to microphone positions. *Acta Acust. United Acust.* 1999, **85**, pp. 88–100
- [6] HOPKINS C., & TURNER P. Field measurement of airborne sound insulation between rooms with non-diffuse sound fields at low frequencies. *Appl. Acoust.* 2005, **66**, pp. 1339–1382
- [7] HOPKINS C. On the efficacy of spatial sampling using manual scanning paths to determine the spatial average sound pressure level in rooms. *J. Acoust. Soc. Am.* 2011, **129** (5), pp. 3027–3034
- [8] YOSHIMURA J., ANDOW K., KOGA T. Short time methods for field measurement of sound insulation between rooms. *Proceedings of Internoise*. Liverpool, UK. 1996, pp. 2737–2742.
- [9] HOPKINS C. *Sound insulation*. Elsevier/Butterworth-Heinemann, Amsterdam, 2007
- [10] QUIRT J.D. Sound fields near exterior building surfaces. *J. Acoust. Soc. Am.* 1985, **77** (2), pp. 557–566
- [11] BRADLEY J.S., & CHU W.T. Errors when using façade measurements of incident aircraft noise. *Proceedings of Internoise*, Dearborn, MI, USA, 2002
- [12] HOPKINS C., & LAM Y. Sound fields near building façades – comparison of finite and semi-infinite reflectors on a rigid ground plane. *Appl. Acoust.* 2009, **70**, pp. 300–308
- [13] SANCHEZ BOTE J.L., GONZALEZ A.P., ALFAGEME J.J.G. Influence of loudspeaker directivity and measurement geometry on direct acoustic levels over façades for acoustic insulation tests with the International Standard ISO 140-5. *Appl. Acoust.* 2012, **73**, pp. 440–453
- [14] SANCHEZ BOTE J.L., GONZALEZ A.P., ALFAGEME J.J.G. Procedure for verification of sound source coverage over façades according to the International Standard ISO 140-5. *Appl. Acoust.* 2012, **73**, pp. 977–985

---

1) Organisation Internationale de Métrologie Légale, 11 rue Turgot, 75009 Paris, France

