**Road vehicles — Cleanliness of
components of fluid circuits —**

Part 10:
Expression of results

*Véhicules routiers — Propreté des composants des circuits de fluide —
Partie 10: Expression des résultats*



Reference number
ISO 16232-10:2007(E)

© ISO 2007

PDF disclaimer

This PDF file may contain embedded typefaces. In accordance with Adobe's licensing policy, this file may be printed or viewed but shall not be edited unless the typefaces which are embedded are licensed to and installed on the computer performing the editing. In downloading this file, parties accept therein the responsibility of not infringing Adobe's licensing policy. The ISO Central Secretariat accepts no liability in this area.

Adobe is a trademark of Adobe Systems Incorporated.

Details of the software products used to create this PDF file can be found in the General Info relative to the file; the PDF-creation parameters were optimized for printing. Every care has been taken to ensure that the file is suitable for use by ISO member bodies. In the unlikely event that a problem relating to it is found, please inform the Central Secretariat at the address given below.



COPYRIGHT PROTECTED DOCUMENT

© ISO 2007

All rights reserved. Unless otherwise specified, no part of this publication may be reproduced or utilized in any form or by any means, electronic or mechanical, including photocopying and microfilm, without permission in writing from either ISO at the address below or ISO's member body in the country of the requester.

ISO copyright office
Case postale 56 • CH-1211 Geneva 20
Tel. + 41 22 749 01 11
Fax + 41 22 749 09 47
E-mail copyright@iso.org
Web www.iso.org

Published in Switzerland

Contents

Page

Foreword	iv
Introduction	v
1 Scope	1
2 Normative references	1
3 Terms and definitions	2
4 Principles	2
5 Expression of results of gravimetric analysis	2
5.1 Necessary data	2
5.2 Expression of results	2
6 Expression of results of particle size distribution analysis - Component Cleanliness Code, CCC	3
6.1 Necessary data	3
6.2 Size classes	3
6.3 Contamination level	5
6.4 Component Cleanliness Code (CCC)	5
7 Expression of results by the number of particles per component	6
7.1 Size classes	6
7.2 Contamination level	6
7.3 Component Cleanliness Code	6
8 Largest particle	7
9 Test report	7
Annex A (informative) Recommendation of use of the Component Cleanliness Code (CCC)	9
Annex B (informative) Determination of the wetted volume of a component	10
Annex C (informative) Examples of Component Cleanliness Codes	13
Annex D (informative) Alternative transitional expression of cleanliness	15
Annex E (informative) Example of test report - Cleanliness inspection report according to ISO 16232	16
Bibliography	19

Foreword

ISO (the International Organization for Standardization) is a worldwide federation of national standards bodies (ISO member bodies). The work of preparing International Standards is normally carried out through ISO technical committees. Each member body interested in a subject for which a technical committee has been established has the right to be represented on that committee. International organizations, governmental and non-governmental, in liaison with ISO, also take part in the work. ISO collaborates closely with the International Electrotechnical Commission (IEC) on all matters of electrotechnical standardization.

International Standards are drafted in accordance with the rules given in the ISO/IEC Directives, Part 2.

The main task of technical committees is to prepare International Standards. Draft International Standards adopted by the technical committees are circulated to the member bodies for voting. Publication as an International Standard requires approval by at least 75 % of the member bodies casting a vote.

Attention is drawn to the possibility that some of the elements of this document may be the subject of patent rights. ISO shall not be held responsible for identifying any or all such patent rights.

ISO 16232-10 was prepared by Technical Committee ISO/TC 22, *Road vehicles*, Subcommittee SC 5, *Engine tests*.

ISO 16232 consists of the following parts, under the general title *Road vehicles — Cleanliness of components of fluid circuits*:

- *Part 1: Vocabulary*
- *Part 2: Method of extraction of contaminants by agitation*
- *Part 3: Method of extraction of contaminants by pressure rinsing*
- *Part 4: Method of extraction of contaminants by ultrasonic techniques*
- *Part 5: Method of extraction of contaminants on functional test bench*
- *Part 6: Particle mass determination by gravimetric analysis*
- *Part 7: Particle sizing and counting by microscopic analysis*
- *Part 8: Particle nature determination by microscopic analysis*
- *Part 9: Particle sizing and counting by automatic light extinction particle counter*
- *Part 10: Expression of results*

Introduction

The presence of particulate contamination in a fluid system is acknowledged to be a major factor governing the life and reliability of that system. The presence of particles residual from the manufacturing and assembly processes will cause a substantial increase in the wear rates of the system during the initial run-up and early life, and may even cause catastrophic failures.

In order to achieve reliable performance of components and systems, control over the amount of particles introduced during the build phase is necessary, and measurement of particulate contaminants is the basis of control.

The ISO 16232 series has been drafted to fulfil the requirements of the automotive industry, since the function and performance of modern automotive fluid components and systems are sensitive to the presence of a single or a few critically sized particles. Consequently, ISO 16232 requires the analysis of the total volume of extraction liquid and of all contaminants collected using an approved extraction method.

The ISO 16232 series has been based on existing ISO International Standards such as those developed by ISO/TC 131/SC 6. These International Standards have been extended, modified and new ones have been developed to produce a comprehensive suite of International Standards to measure and report the cleanliness levels of parts and components fitted to automotive fluid circuits.

This part of ISO 16232 defines rules for expressing these cleanliness levels when measured by the methods defined in ISO 16232-6, ISO 16232-7, ISO 16232-8 and ISO 16232-9.

Users of the ISO 16232 series introducing this coding system are encouraged to inform the ISO/TC 22/SC 5 secretariat of any problems met, through their national standards organization.

1

Road vehicles — Cleanliness of components of fluid circuits —

Part 10: Expression of results

1 Scope

This part of ISO 16232 defines the rules and the forms of expression and presentation of the results of measurements of particulate cleanliness of components for the fluid circuits of motor vehicles. It also defines a cleanliness coding system for simplifying the reporting and communication of particulate contamination data.

This part of ISO 16232 also defines the rules to be used for specifying cleanliness requirements.

This part of ISO 16232 does not concern the expression of particulate cleanliness of fluids.

2 Normative references

The following referenced documents are indispensable for the application of this document. For dated references, only the edition cited applies. For undated references, the latest edition of the referenced document (including any amendments) applies.

ISO 16232-1, *Road vehicles — Cleanliness of components of fluid circuits — Part 1: Vocabulary*

ISO 16232-2, *Road vehicles — Cleanliness of components of fluid circuits — Part 2: Method of extraction of contaminants by agitation*

ISO 16232-3, *Road vehicles — Cleanliness of components of fluid circuits — Part 3: Method of extraction of contaminants by pressure rinsing*

ISO 16232-4, *Road vehicles — Cleanliness of components of fluid circuits — Part 4: Method of extraction of contaminants by ultrasonic techniques*

ISO 16232-5, *Road vehicles — Cleanliness of components of fluid circuits — Part 5: Method of extraction of contaminants on functional test bench*

ISO 16232-6, *Road vehicles — Cleanliness of components of fluid circuits — Part 6: Particle mass determination by gravimetric analysis*

ISO 16232-7, *Road vehicles — Cleanliness of components of fluid circuits — Part 7: Particle sizing and counting by microscopic analysis*

ISO 16232-8, *Road vehicles — Cleanliness of components of fluid circuits — Part 8: Particle nature determination by microscopic analysis*

ISO 16232-9, *Road vehicles — Cleanliness of components of fluid circuits — Part 9: Particle sizing and counting by automatic light extinction particle counter*

3 Terms and definitions

For the purposes of this document, the terms and definitions given in ISO 16232-1 apply.

4 Principles

Particulate contamination, as measured in the whole volume of extraction fluid used in one of the methods of extraction and analyses described in ISO 16232 series, is quantified:

- per component;
- to a reference surface of 1 000 cm² of wetted surface of a component;
- to a reference volume of 100 cm³ of wetted volume of a component.

The level of particulate contamination can be expressed by the total mass, by the particle-size distribution (number of particles per size class) possibly combined with the nature of particles or by the dimension of the largest particle(s) found. Data can also be combined, e.g. total mass and largest particle.

Cleanliness levels shall only be compared if they are in the same measurement units, i.e. either per 1000 cm² of wetted surface area or 100 cm³ of wetted volume.

The cleanliness levels expressed per component shall never be compared one with the other. They shall only be used to compare a result to a specification.

Annex A gives recommendation for using the appropriate Component Cleanliness Code (CCC) codification.

NOTE In view of the different physical principles used to evaluate the size of the particles (e.g. a microscope or a light extinction automatic particle counter), the particulate contamination level measured on the same extraction sample can be different.

5 Expression of results of gravimetric analysis

5.1 Necessary data

The expression of the results of a gravimetric analysis requires knowledge of the following characteristics:

- 1) wetted volume (V_C) or wetted surface area (A_C) or V_C/A_C ratio of the component (see Annex B for an example);
- 2) number of components analysed if the contaminants are collected from more than one component;
- 3) total mass (mg) of contaminants collected by extraction.

NOTE There is no relationship between the gravimetric analysis results and the other contamination analysis results (e.g. particle counting).

5.2 Expression of results

5.2.1 Mass per component (m_{Cp})

Let n be the number of components analysed and m the total mass of contaminants collected, then:

$$m_{Cp} = \frac{m}{n} \text{ mg per component}$$

When low weight or/and small components are analysed, the result can be expressed as the mass of contaminants for n components. This is written as:

$$m_{Cp} = m \text{ mg for } n \text{ components}$$

NOTE The cleanliness level reported by the mass per component varies arbitrarily depending on both, the size of the part and amount of its contamination.

5.2.2 Mass per unit surface area of component (m_A)

If A_C is the wetted surface area of the component (cm^2) and m the total mass (mg) of contaminant collected, then:

$$m_A = \frac{m \times 1000}{A_C} \text{ in mg/1000 cm}^2 \text{ of component}$$

5.2.3 Mass per unit volume of component (m_V)

If V_C is the wetted volume of the component (cm^3) and m the total mass (mg) of contaminant collected, then:

$$m_V = \frac{m \times 100}{V_C} \text{ in mg/100 cm}^3 \text{ of component}$$

6 Expression of results of particle size distribution analysis - Component Cleanliness Code, CCC

6.1 Necessary data

To present the data from the extraction tests in this form and obtain the CCC requires the information detailed in 5.1 and the following:

- all or part of the counting size intervals chosen from Table 1 as specified in the inspection document;
- wetted volume (V_C) or wetted surface area (A_C) or V_C/A_C ratio of the component (see Annex B for an example);
- number of components analysed if the contaminants are collected from more than one component;
- the numbers of the particles extracted from the component(s) analysed in each of the specified size ranges.

6.2 Size classes

The particles are counted in all or part of the size ranges defined by an inclusive lower size (called x_1) and an exclusive higher one (called x_2) among those listed in Table 1.

Each size range is labelled by a letter which defines a size class.

Table 1 — Size classes for particle counting

Size class	Size x (μm)
B	$5 \leq x < 15$
C	$15 \leq x < 25$
D	$25 \leq x < 50$
E	$50 \leq x < 100$
F	$100 \leq x < 150$
G	$150 \leq x < 200$
H	$200 \leq x < 400$
I	$400 \leq x < 600$
J	$600 \leq x < 1\ 000$
K	$1\ 000 \leq x$

NOTE According to individual requirements, size ranges may be combined and/or left out.

Table 2 — Definition of the cleanliness level of a component

Number of particles per 100 cm ³ or per 1 000 cm ²		Cleanliness level
More than	Up to and including	
0	0	00
0	1	0
1	2	1
2	4	2
4	8	3
8	16	4
16	32	5
32	64	6
64	130	7
130	250	8
250	500	9
500	1×10^3	10
1×10^3	2×10^3	11
2×10^3	4×10^3	12
4×10^3	8×10^3	13
8×10^3	16×10^3	14
16×10^3	32×10^3	15
32×10^3	64×10^3	16
64×10^3	130×10^3	17
130×10^3	250×10^3	18
250×10^3	500×10^3	19
500×10^3	1×10^6	20
1×10^6	2×10^6	21
2×10^6	4×10^6	22
4×10^6	8×10^6	23
8×10^6	16×10^6	24

NOTE In the test report, it is advisable that the raw number of particles also be noted.

6.3 Contamination level

The level of particulate contamination of a component in a given particle size class is expressed by the number specified in Table 2 as a function of the number of particles counted on the component with respect to the geometrical unit (100 cm^3 or $1\,000 \text{ cm}^2$) chosen.

6.4 Component Cleanliness Code (CCC)

6.4.1 The Cleanliness Code of Components (CCC) is written as a sequence, enclosed in parentheses and separated by slashes, of alphanumerical pairs specifying all or several of the size classes from Table 1 and their level of contamination given by Table 2.

The capital letters A or V printed before the parentheses explains if the code refers either to $1\,000 \text{ cm}^2$ of wetted surface area or to 100 cm^3 of wetted volume of the component.

6.4.2 When the CCC refers to the whole size ranges all letters of Table 1 and corresponding levels are written: for instance

CCC = V (B20/C16/D18/E12/F12/G12/H8/I0/J0/K00)

6.4.3 When the CCC refers to some size classes, only the relevant letters and corresponding levels are written: for instance

CCC = V (C16/D18/E12/F12/G12/J0)

means that there was no requirement (or no results) for cleanliness data at size ranges B, H, I and K.

6.4.4 When several successive size classes are at the same cleanliness level, they are reported by their letters side by side and the relevant level is written after the last letter: e.g. : .../EFG12/...

CCC = V (C16/D18/EFG12/H8/J0)

means that between $2\,000$ and $4\,000$ particles (level 12) are in three size ranges $50 \leq x < 100$ (size E), $100 \leq x < 150$ (size F) and $150 \leq x < 200$ (size G) μm and that there is no requirement or data for size B, I and K.

6.4.5 When the cleanliness level relates to a size range broader than the ones of Table 1, i.e. it covers several consecutive size classes, it is labelled by the letters of the lower and higher sizes linked by an hyphen (-) followed by the relevant level, e.g.:/G-J20/.....

CCC = V (C16/D18/EF12/G-J20)

means between 500×10^3 and 10^6 particles (level 20) between 150 and less than $1\,000 \mu\text{m}$ (sizes G to J) and no requirement or data at other sizes.

CCC = V (G-K20)

means between 500×10^3 and 10^6 particles (level 20) greater than $150 \mu\text{m}$ (sizes G to K) and no requirement or data at other sizes.

CCC = V (G-K00)

means no particle (level 00) greater than $150 \mu\text{m}$ (sizes G to K) and no requirement or data at other sizes.

Other examples are given in Annex C.

6.4.6 Alternative transitional expression of cleanliness

Due to some existing practice, Annex D gives an alternative transitional expression of cleanliness.

7 Expression of results by the number of particles per component

7.1 Size classes

The size classes are specified in Table 3.

Table 3 — Size classes for particle counting

Size class	Size x (μm)
B	$5 \leq x < 15$
C	$15 \leq x < 25$
D	$25 \leq x < 50$
E	$50 \leq x < 100$
F	$100 \leq x < 150$
G	$150 \leq x < 200$
H	$200 \leq x < 400$
I	$400 \leq x < 600$
J	$600 \leq x < 1\ 000$
K	$1\ 000 \leq x$

7.2 Contamination level

The contamination level is expressed by the number of particles per component.

7.3 Component Cleanliness Code

7.3.1 The code is written as the sequence, enclosed in parentheses and separated by slashes, of alphanumerical pairs specifying all or several of size classes from Table 3 and its rounded number of particles per component.

The letter N (for number) is written before the first parenthesis.

CCC = N (B585600/C58200/D180500/E3600/F2800/G2900/H190/I4/J0)

7.3.2 When the number of particles relates to a size range broader than the ones of Table 3, i.e. covers several consecutive size classes, the range is expressed by the letters of the lower and the higher sizes linked by an hyphen (-) followed by the relevant number.

e.g.: N (G-K 40) means 40 or less than 40 particles are larger than 150 μm (sizes G to K) per component.

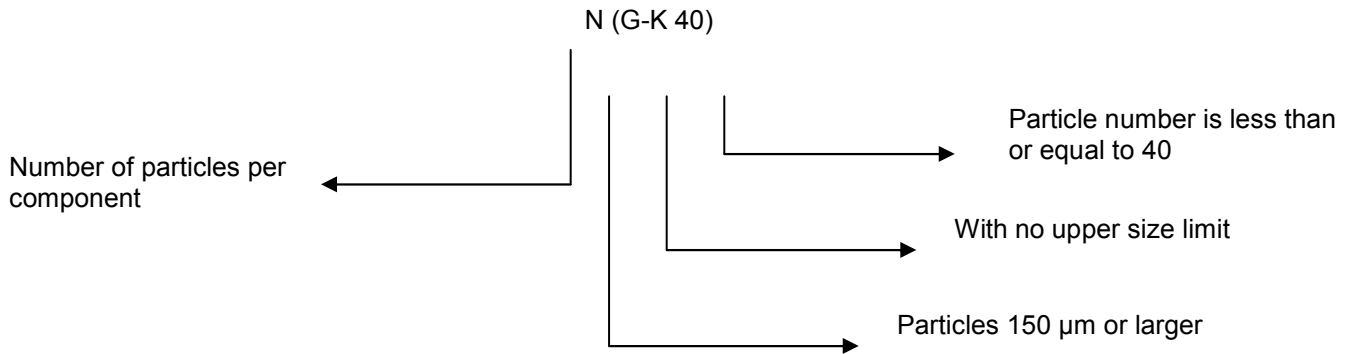

7.3.3 Other cases are reported as specified in 6.4.

8 Largest particle

If the particulate contamination of a component has to be expressed by the size of the largest particle report as X = "size" in micrometres.

EXAMPLE $X = 650 \mu\text{m}$

9 Test report

9.1 The test report on the cleanliness of a component shall contain the details listed in 9.2 and the reference to the inspection document used. The details contained in the inspection document shall not be supplied together with each inspection report. Those details shall be included with the test report.

9.2 The report details shall be:

- Date
- Identification of the laboratory
- Identification of the laboratory's customer/client
- Identification of the analysis and the report
- Operator or authorised signature
- Identification of the component analysed:
 - component part number;
 - supplier;
 - wetted volume (V_C) or wetted surface area (A_C), (optional);

ISO 16232-10:2007(E)

- origin and date of component sampling;
- number of components.
- Conditions of extraction and analysis:
 - reference of extraction procedure;
 - number of components analysed;
 - type of extraction (agitation, pressure rinsing, ultrasonic bath, functional test bench);
 - type of environment where the analysis has been performed.
- Results of analysis of the extraction sample(s):
 - a) Expression of the gravimetric analysis:
 - reference of the method of analysis;
 - volume of extraction liquid analysed;
 - manufacturer, part number, diameter and mean flow pore size (MFPS) of the membrane filter;
 - blank value;
 - mass of the membrane filter, first clean and then after filtration;
 - mass of contaminants retained;
 - mass of contaminants per 100 cm³ of wetted volume or per 1 000 cm² of wetted surface area or per component.
 - b) Expression of the particle Size Distribution analysis:
 - type and reference of the method of counting (automatic count, optical microscopy or with image analyser);
 - volume of test liquid analysed;
 - characteristics of the membrane filter (MFPS, diameter, colour);
 - references of the equipment and date of calibration;
 - blank value;
 - total number of particles counted in each of the size classes chosen in the blank test and in the component test;
 - number of particles per 100 cm³ or per 1 000 cm² of component in each size class;
 - component cleanliness code.

9.3 An example of test report is given in Annex E.

Annex A (informative)

Recommendation of use of the Component Cleanliness Code (CCC)

A.1 Code per wetted surface area of component [CCC (A)]

The use of CCC per wetted surface area is recommended for solid parts without an included volume of service liquid (i.e. they are immersed in the liquid). It can be used by test laboratories and/or by manufacturers of non-hollow components or of hollow components when the functional volume of the system, the sub-assembly or the component in which the test part/component is included is not specified.

It is recommended for manufacturers of hollow components to specify their requirements to their part suppliers. The code per unit surface area is recommended for evaluating or specifying requirements for a washing process.

A.2 Code per wetted volume of component [CCC (V)]

The use of CCC per wetted volume of component is recommended:

- to specify a requirement and express a result on all hollow parts and components (i.e. having an included volume);
- to characterize an assembled system in which a liquid will circulate which has a cleanliness level expressed by ISO 4406;
- to system and assembly designers to specify their requirements to their sub-assembly and component suppliers;
- to specify, in the same way, the cleanliness level of components, sub-assembly of which they will be part of, liquid systems on which they will be installed, liquid which will fill the system, and the final system.

Annex B (informative)

Determination of the wetted volume of a component

B.1 Introduction

To express the particulate contamination of a component as either a mass or a number of particles per 100 cm³ of wetted volume, this volume can either be measured or calculated if the component is hollow, or the method of approximation of an equivalent wetted volume can be used if the component is solid (a pinion in a gear train, for example), using the concept of the equivalent sphere, or else the ratio of volume to area of the component or system can be applied.

B.2 Experimental method

The wetted volume or capacity (V_C) of a “hollow” component can be measured experimentally by following the steps below:

- a) make sure that the inside of the test component is dry;
- b) plug all openings except the one or more required for complete filling;
- c) prepare a volume of test liquid (V_1), known to within 1 %, of about 1,3 times the presumed wetted volume of the component;

NOTE 1 The test liquid should be compatible with the materials of the component and its kinematic viscosity should preferably be less than 5 mm²/s at the test temperature.

NOTE 2 It has been found practical to weigh this volume in its container, after establishing the tare weight of the latter, and then to divide its mass by its specific gravity.

- d) carefully fill the component with test liquid making sure not to trap any air; to do this, move it gently in suitable directions so that every part of it is filled with liquid;

NOTE 3 Adjustment of the filling volume can be facilitated by using a syringe that can be emptied completely.

- e) determine the volume (V_2) remaining in the container of the liquid in c);
- f) determine the volume (V_C) that was needed to fill the component:

$$V_C = V_1 - V_2$$

B.3 Method by calculation

B.3.1 Direct calculation

If the Computer Aided Design software possesses the function, calculate the wetted volume of the component.

B.3.2 Indirect calculation

B.3.2.1 Equivalent sphere concept

a) Hollow component

If the wetted volume of the component is not known and cannot be calculated directly, and if its wetted surface (A_C) is known, the size of the void volume can be approximated by considering that its surface area is that of a sphere and then by calculating the volume of the equivalent sphere (V_S), applying the relation:

$$V_S = \frac{A_C^{\frac{3}{2}}}{6\sqrt{\pi}}$$

NOTE Since a sphere always represents the maximum closed volume of a given surface, the actual volume of the component will nearly always be less than this. For the purposes of calculation, the calculated volume (V_C) is assumed to be 80 % of the spherical volume calculated on the basis of its surface area:

$$V_C = 0,8 \times V_S = 0,13 \frac{A_C^{\frac{3}{2}}}{\sqrt{\pi}} = 0,073 \frac{A_C^{\frac{2}{3}}}{\sqrt{\pi}}$$

b) Full component

If the component has no real wetted volume (O-ring seal, gear train pinion, piston rod, etc.), its equivalent spherical volume (V_S) can be approximated in the same way by considering the volume of a sphere of equal wetted surface. The formula in B.3.2.1.a) is then applied to the external surface (A_C) of the component in contact with the fluid.

B.3.2.2 Ratios of wetted volume to wetted surface area

If the wetted surface area A_C and the ratio V_C/A_C of the component are known, calculate its volume V_C by the formula:

$$V_C = A_C \times \frac{V_C}{A_C}$$

If the wetted surface area A_C of the component and the ratio V_S/A_S of the fluid system are known, calculate its volume V_C by the formula:

$$V_C = A_C \times \frac{V_S}{A_S}$$

B.3.3 Wetted volume (V_C)

To illustrate how to calculate or measure the wetted volume, a gear pump is used as an example.

The wetted volume of an external gear pump is the sum of the volumes between the teeth and of the volume contained between the body and the two pinions. It is also the volume of the body less the volume of the two pinions (see Figure B.2). It is determined experimentally by measurement of the filling volume of the complete pump (see B.2).

B.3.4 Wetted surface area (A_C)

The wetted surface of an external gear pump is the sum of the internal surface areas of the body of the pump (2 plates + 1 plate with 2 ports) and the external surface area of the two pinions (see Figure B.3).

B.3.5 Illustration

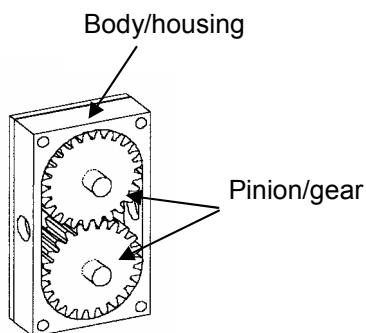
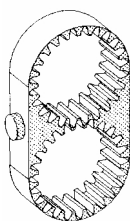
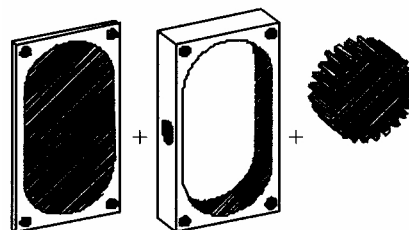

Figure B.1 — Gear pump



$$V_C = V_P - 2V_{Pi}$$

Figure B.2 — Wetted volume V_C



$$A_C = 2A_{PL} + A_B + 2A_{Pi}$$

Figure B.3 — Wetted surface area A_C

Key

- A_{PL} plate wetted surface area
- A_B body internal surface area
- A_{Pi} pinion external surface area
- $V_P =$ pump body volume
- $V_{Pi} =$ pinion gear volume

Annex C (informative)

Examples of Component Cleanliness Codes

C.1 Reporting results

C.1.1 The numbers (N) of particles counted in a standardised volume of 100 cm³ for a component are reported in column 3 of Table C.1.

C.1.2 By comparing these numbers (column 3) to cleanliness level limits of Table 2, it is possible to fill in column (4) giving the cleanliness level in each size class.

Table C.1 — Example of particle count result

(1) Size class	(2) Size range (μm)	(3) Differential count (N/100cm ³)	(4) Corresponding cleanliness level
B	$5 \leq x < 15$	755 840	20
C	$15 \leq x < 25$	43 720	16
D	$25 \leq x < 50$	220 135	18
E	$50 \leq x < 100$	3 880	12
F	$100 \leq x < 150$	2 510	12
G	$150 \leq x < 200$	3 625	12
H	$200 \leq x < 400$	180	8
I	$400 \leq x < 600$	0,5	0
J	$600 \leq x < 1\ 000$	0,8	0
K	$1\ 000 \leq x$	0	00

C.1.3 The full CCC can then be expressed as follows:

Either $\text{CCC} = \text{V} (\text{B}20/\text{C}16/\text{D}18/\text{E}12/\text{F}12/\text{G}12/\text{H}8/\text{I}0/\text{J}0/\text{K}00)$,

Or $\text{CCC} = \text{V} (\text{B}20/\text{C}16/\text{D}18/\text{EFG}12/\text{H}8/\text{I}0/\text{K}00)$.

C.1.4 If the CCC only refers to sizes greater than 50, 100 and 400 μm :

From column (3), counts greater than 50 μm are $3\ 880+2\ 510+3\ 625+180+0,5+0,8 = 10\ 196,3$, which corresponds to level 14; counts greater than 100 μm are $2\ 510+3\ 625+180+0,5+0,8 = 6\ 316,3$, which corresponds to level 13 and counts greater than 400 μm are $0,5+0,8 = 1,3$, which corresponds to level 1.

CCC is written as follows:

$\text{CCC} = \text{V} (\text{E-K}14/\text{F-K}13/\text{I-K}1)$.

C.2 Specifying requirements and interpreting results

C.2.1 ISO 4406 is sometimes erroneously used to report component cleanliness level as, for example: ISO 4406 -/22/16. This would be written as CCC = V (B-K22/C-K16).

C.2.2 Component in class 9 per NAS 1638¹⁾ writes: CCC = V (B17/C15/D13/E10/F-K8).

C.2.3 For a component not having any particles greater than 150 µm, the CCC is written as:

CCC = V (G-K00) or CCC = A (G-K00)

C.2.4 Component at a level of CCC = V (B22/E-H12/I-K00) means that it shall not contain in 100 cm³ of wetted volume more than 4×10^6 particles between 5 (included) and 15 µm (excluded), nor more than 4 000 particles between 50 and 400 µm and no particle greater than 400 µm.

1) NAS 1638 has been withdrawn and superseded by SAE AS 4059.

Annex D (informative)

Alternative transitional expression of cleanliness

The alternative transitional expression of cleanliness used the size class according to Table 1 in 6.2 omitting the letter codification and number of particles and specifying the reference unit.

For the following example, the counting results are expressed in Table D.1.

Table D.1 — Example of counting results

ISO code (size classes due to ISO 16232)	B	C	D	E
Size range according to 16232	$5 \leq x < 15$	$15 \leq x < 25$	$25 \leq x < 50$	$50 \leq x < 100$
Number of particles	100 000	50 000	15 000	8
16232 ISO code	17	16	14	4

The expression of cleanliness according to this part of ISO 16232 is:

CCC = V (B17/C16/D14/E4)

The following coding may be used to specify cleanliness level for a limited period:

Cleanliness per volume (for instance)

Table D.2 — Example of transitional expression of result

B	C	D	E
$5 \leq x < 15$	$15 \leq x < 25$	$25 \leq x < 50$	$50 \leq x < 100$
100 000	50 000	15 000	8

Annex E
(informative)

**Example of test report - Cleanliness inspection report according to
ISO 16232**

E.1 Laboratory identification

Company: Tel: Fax: Email:
Address:

E.2 Customer identification

Company: Contact:
Address: Order:

E.3 Analysis and report identification

Report Number: Analysis date:
Operator:

E.4 Analysed component identification

Reference: Wetted surface A_C = cm²
Supplier: Wetted volume V_C = cm³
Sampling: Origin: Date: Part Number: Item:

E.5 Extraction conditions

Extraction Procedure ref.:

Number of parts analysed:

Type Method ^a Agitation Pressure rinsing Ultrasonic Functional test
 acc.to:..... acc. to: acc. to: acc. to:.....

Analysis environment: Industrial Laboratory Controlled (class ISO 14644 -1:)

^a Give the number or reference of the extraction method used.

E.6 Analysis report

E.6.1 Mass of contaminant

Procedure: ISO 16232-6 Other, specify:

Analysed volume: $V_A = \dots\dots\dots$ mL

Membrane filter: Material: Diameter..... mm MFPS ^a: μ m

Blank gravimetric level: mg

Membrane mass: Before filtration:.... mg After filtration: mg Retained mass of contaminant: $m_C = \dots$ mg

Mass of contaminant in $m_{Cp} = \dots$ mg/component or $m_A = \dots\dots\dots$ mg/1 000 cm^2 or $m_V = \dots\dots\dots$ mg/100 cm^3 the component:

^a Mean flow pore diameter.

E.6.2 Number and size of contaminants

Analysed volume: $V_A =$

Analysis procedure

Optical microscope: Binocular: SEM + EDX APC ^a: Other, specify:
 acc. to acc. to acc. to acc. to

Membrane filter: Material: MFPS ^b : μ m Diam mm

Colour :

^a Automatic particle counter.

^b Mean flow pore diameter.

E.6.3 Particle count data and Component cleanliness code (CCC)

Size class	B	C	D	E	F	G	H	I	J	K
Size range (µm)	$5 \leq x < 15$	$15 \leq x < 25$	$25 \leq x < 50$	$50 \leq x < 100$	$100 \leq x < 150$	$150 \leq x < 200$	$200 \leq x < 400$	$400 \leq x < 600$	$600 \leq x < 1\ 000$	$1\ 000 \leq x$
Blank count										
Particle counts										
Standardised counts ^a Number per: <input type="checkbox"/> 1000 cm ² <input type="checkbox"/> 100 cm ³ <input type="checkbox"/> component										
Cleanliness Level <input type="checkbox"/> V <input type="checkbox"/> A <input type="checkbox"/> C ^a										

COMPONENT CLEANLINESS CODE: CCC = ^b (/ / / ... /)

^a Tick the appropriate box

^b Specify: V if per 100 cm³; A if per 1000 cm² or C if per component.

E.6.4 Largest particle

X =µm Nature:

E.7 Remarks/comments

Bibliography

- [1] ISO 4406:1999, *Hydraulic fluid power — Fluids — Method for coding the level of contamination by solid particles*
- [2] ISO 14644-1:1999, *Cleanrooms and associated controlled environments — Part 1: Classification of air cleanliness*
- [3] NAS 1638, *Cleanliness requirements of parts used in hydraulic systems*
- [4] SAE AS 4059, *Aerospace fluid power — Cleanliness classification for hydraulic fluids*

ICS 13.040.50; 43.180

Price based on 19 pages