**Agricultural irrigation equipment —
PVC above-ground low-pressure pipe
for surface irrigation — Specifications
and test methods**

*Matériel agricole d'irrigation — Tube en PVC, posé au-dessus du sol et
utilisé avec basse pression pour l'irrigation en surface — Spécifications
et méthodes d'essai*



PDF disclaimer

This PDF file may contain embedded typefaces. In accordance with Adobe's licensing policy, this file may be printed or viewed but shall not be edited unless the typefaces which are embedded are licensed to and installed on the computer performing the editing. In downloading this file, parties accept therein the responsibility of not infringing Adobe's licensing policy. The ISO Central Secretariat accepts no liability in this area.

Adobe is a trademark of Adobe Systems Incorporated.

Details of the software products used to create this PDF file can be found in the General Info relative to the file; the PDF-creation parameters were optimized for printing. Every care has been taken to ensure that the file is suitable for use by ISO member bodies. In the unlikely event that a problem relating to it is found, please inform the Central Secretariat at the address given below.

© ISO 2006

All rights reserved. Unless otherwise specified, no part of this publication may be reproduced or utilized in any form or by any means, electronic or mechanical, including photocopying and microfilm, without permission in writing from either ISO at the address below or ISO's member body in the country of the requester.

ISO copyright office
Case postale 56 • CH-1211 Geneva 20
Tel. + 41 22 749 01 11
Fax + 41 22 749 09 47
E-mail copyright@iso.org
Web www.iso.org

Published in Switzerland

Foreword

ISO (the International Organization for Standardization) is a worldwide federation of national standards bodies (ISO member bodies). The work of preparing International Standards is normally carried out through ISO technical committees. Each member body interested in a subject for which a technical committee has been established has the right to be represented on that committee. International organizations, governmental and non-governmental, in liaison with ISO, also take part in the work. ISO collaborates closely with the International Electrotechnical Commission (IEC) on all matters of electrotechnical standardization.

International Standards are drafted in accordance with the rules given in the ISO/IEC Directives, Part 2.

The main task of technical committees is to prepare International Standards. Draft International Standards adopted by the technical committees are circulated to the member bodies for voting. Publication as an International Standard requires approval by at least 75 % of the member bodies casting a vote.

Attention is drawn to the possibility that some of the elements of this document may be the subject of patent rights. ISO shall not be held responsible for identifying any or all such patent rights.

ISO 16149 was prepared by Technical Committee ISO/TC 23, *Tractors and machinery for agriculture and forestry*, Subcommittee SC 18, *Irrigation and drainage equipment and systems*.

Agricultural irrigation equipment — PVC above-ground low-pressure pipe for surface irrigation — Specifications and test methods

1 Scope

This International Standard specifies the requirements for unplasticized polyvinyl chloride (PVC) piping, used to supply and to distribute low-pressure irrigation water through gates. It is applicable to PVC piping with diameters of from 50 mm to 315 mm, operating at low pressures and exposed to sunlight.

2 Normative references

The following referenced documents are indispensable for the application of this document. For dated references, only the edition cited applies. For undated references, the latest edition of the referenced document (including any amendments) applies.

ISO 1167-1, *Thermoplastics pipes, fittings and assemblies for the conveyance of fluids — Determination of the resistance to internal pressure — Part 1: General method*

ISO 1167-2, *Thermoplastics pipes, fittings and assemblies for the conveyance of fluids — Determination of the resistance to internal pressure — Part 2: Preparation of pipe test pieces*

ISO 2505 (all parts), *Thermoplastics pipes — Longitudinal reversion*

ISO 2507-1, *Thermoplastics pipes and fittings — Vicat softening temperature — Part 1: General test method*

ISO 2507-2, *Thermoplastics pipes and fittings — Vicat softening temperature — Part 2: Test conditions for unplasticized poly(vinyl chloride) (PVC-U) or chlorinated poly(vinyl chloride) (PVC-C) pipes and fittings and for high impact resistance poly(vinyl chloride) (PVC-HI) pipes*

ISO 9852, *Unplasticized poly(vinyl chloride) (PVC-U) pipes — Dichloromethane resistance at specified temperature (DCMT) — Test method*

3 Terms and definitions

For the purposes of this document, the following terms and definitions apply.

3.1 bell

receiving shape at one end of a section of pipe that serves as a watertight seal when the spigot end of an adjoining pipe section is inserted into the bell

3.2 bevel

smoothed annular and angular area at the end of the spigot for assisting in the coupling of the bell and spigot joint

- 3.3**
dichloromethane resistance
resistance following exposure to dichloromethane in order to give an indication of the level of gelation in the pipe and of the uniformity of that gelation
- 3.4**
gate
adjustable opening in the pipe which allows water to be released
- 3.5**
impact strength
measure of the brittleness or the toughness of a material
- 3.6**
longitudinal reversion
change in length of a pipe under higher-than-ambient temperature estimated by subjecting a test portion of pipe immersed in an inert liquid maintained at a temperature of 150 °C for a period of time determined by the wall thickness of the pipe
- 3.7**
low pressure
pressure less than 100 kPa
- 3.8**
nominal pipe diameter
reference value for the size of a gated pipe approximately equal to the outside diameter of the pipe, rounded to the nearest millimetre
- 3.9**
spigot
inserting end of a section of pipe in the bell
- 3.10**
vicat softening temperature
temperature at which a standard indenter under a force of 50 N penetrates 1 mm into the surface of a test piece cut from the wall of a pipe while the temperature is raised at a constant rate of 50 °C/h
- 3.11**
maximum working pressure
highest water pressure at the inlet to a gated pipe unit recommended by the manufacturer to ensure proper operation

4 Marking

Each pipe shall bear clear and permanent markings, including the following:

- a) name of manufacturer or registered trademark of the manufacturer;
- b) classification code of the material;
- c) nominal diameter;
- d) reference to this International Standard (i.e. ISO 16149);
- e) production code — compound, extruder, year, month, day, shift.

5 Specifications

5.1 General

The product in conformance with this International Standard shall have specifications according to 5.2 to 5.4.

5.2 Dimensions

5.2.1 Outside diameter

The outside diameter and corresponding tolerances shall be in accordance with Table 1.

Table 1 — Outside diameters and corresponding tolerances

Dimensions in millimetres

Nominal diameter d_n	Outside diameter d_o	Tolerance
50	50	+ 0,3
75	75	+ 0,4
100	100	+ 0,4
125	125	+ 0,5
160	160	+ 0,5
200	200	+ 0,6
250	250	+ 0,8
315	315	+ 0,9
Other diameters may be manufactured by agreement between user and manufacturer.		

5.2.2 Wall thickness

The minimum wall thickness shall be 2,2 mm or the result of the following equation, whichever is the greater:

$$t = \frac{d_o P}{2S + P}$$

where

t is the minimum wall thickness in millimetres (mm);

P is the pressure in kilopascals (kPa);

S is the design stress in kilopascals (kPa);

d_o is the outside diameter, in millimetres (mm).

The wall thickness tolerance shall be + 12 % or 0,8 mm, whichever is the greater.

The dimensions shall be measured according to 8.1.

5.3 Mechanics

5.3.1 Resistance to impact

Select the point of impact to allow for gate stability during the test. The gated pipe shall not break or fracture, nor shall the gate separate from the pipe, when tested according to 8.2.

The test impact force shall be in accordance with Table 2.

Table 2 — Test impact force

Nominal diameter d_n mm	Impact energy	
	N · m	kg · m
50	40	4
75	40	4
160	50	5
200	50	5
250	60	6
315	60	6

NOTE For practical purposes, 1 kg force is equal to 10 N.

5.3.2 Resistance to crushing

A pipe with gates shall show no breaks, splits or cracks and the gates shall not separate or have permanent distortion when crushed according to 8.3.

5.3.3 Resistance to accelerated aging (weathering)

The pipes shall have no cracks, bubbles or other defects that could affect their properties when tested under the conditions according to 8.4.

5.3.4 Watertightness of the joint and of the gate

Test the assembled joints for joint tightness at a pressure of 250 kPa for a period of at least 15 min, under the conditions according to 8.5. No joint leakage shall occur.

5.4 Physics and chemistry

5.4.1 Resistance to dichloromethane

When tested in accordance with 8.6, the tested pipe wall shall resist attack in 100 % of internal and external surfaces and in the bevelled area.

5.4.2 Longitudinal reversion

When the pipe is tested in accordance with 8.7, the specimen length variation shall be < 5 %. The test section shall show no bubbles, fissures or opaque areas, or other noticeable defects.

5.4.3 Vicat softening temperature

When the pipe is tested in accordance with 8.8, the Vicat softening temperature shall be > 80 °C.

6 Flow rate of gates

The test flow rate through the gates at the test pressure recommended by the manufacturer shall not vary by more than + 10 % of that specified by the manufacturer, measured in accordance with 8.9.

NOTE This specification is applicable to pipes subjected to a pressure higher than the atmospheric pressure.

7 Sampling and acceptance number

See Table 3.

Table 3 — Acceptance number

Clause/subclause of this International Standard	Test	Number of test specimens	Acceptance number
4	Marking	13	0
5.1	Dimensions	13	0
5.3.1	Resistance to impact	5	0
5.3.2	Resistance to crushing	5	0
5.3.3	Resistance to accelerated aging	5	0
5.3.4	Watertightness of the joint and the gate	5	0
5.4.1	Resistance to dichloromethane	5	0
5.4.2	Longitudinal reversion	5	0
5.4.3	Vicat softening temperature	5	0
6	Flow rate of gates	13	0

8 Tests

8.1 Measurement of dimensions

8.1.1 General

The precision required in each measurement is 0,025 mm.

8.1.2 Wall thickness

Measure the wall thickness using a micrometer with ball anvil or other measuring instrument having the same precision.

8.1.3 Outside diameter

Ensure that the outside diameter is measured with a slide calliper and the readings rounded off to the nearest 0,1 mm. Take measurements around the same cross-section, perpendicular to the pipe axis, rotating the callipers in the plane of this cross-section until the maximum and minimum values are found.

8.2 Resistance to impact

Ensure that a tup impact tester with a tup-type B nose is used (radius, 50 mm). Ensure that the specimen is at least equal in length to the nominal outside diameter but not less than 150 mm. Condition the test specimens at 23 ± 2 °C and 50 ± 5 % relative humidity for not less than 40 h prior to test. For equipment and procedure details, see Reference [6].

8.3 Resistance to crushing

Ensure that the length of the specimens includes at least one gate near the centre. Crush specimens between parallel plates in a suitable press until the distance between plates is 40 % of the outside diameter of the pipe. Ensure that the rate of loading is uniform and such that the compression is completed within 2 min to 5 min. See also Reference [5].

8.4 Resistance to accelerated aging (weathering)

Ensure that the specimen thickness is < 20 mm. Mount the test specimens in the specimen rack with the test surfaces facing the lamp. When the test specimens do not completely fill the racks, fill the empty spaces with blank panels. Use a cycle and a temperature as follows: 4 h UV at 60 °C, and condensation at 50 °C. For equipment and procedure details, see Reference [6].

8.5 Watertightness of the joint and the gate

Ensure that a cylindrical container type of end cap fitted with adequate temperature and pressure equipment is used to maintain a temperature of 23 ± 2 °C and the pressure according to 5.3.4. Calculate the length of the test pieces from the following equations.

For a diameter less than 250 mm:

$$L = 250 + 3d_o + X$$

For diameters equal or greater than 250 mm:

$$L = 1000 + 2X$$

where

L is the length of the piece test in millimetres (mm);

d_o is the outside diameter in millimetres (mm);

X is the length between end caps of the container in millimetres (mm).

For equipment and procedure details, see ISO 1167-1 and ISO 1167-2.

8.6 Resistance to dichloromethane

Ensure that a container made of stainless steel is used and that it has a capacity suitable to contain both the dichloromethane and the test piece, that it is fitted with equipment suitable for suspending the test piece, and that it is provided with a device for temperature control, capable of maintaining the temperature of the dichloromethane at 20 °C ± 1 °C for 15 min. Remove test pieces at least 100 mm long from the pipe to be tested for resistance to dichloromethane. The equipment and procedure used shall be in accordance with ISO 9852.

8.7 Longitudinal reversion

Use a container with an inert liquid maintained at a temperature of 150 °C ± 2 °C for a period determined in relation to the wall thickness of the pipe, as specified in ISO 2505. The length of the test specimens shall be 200 mm ± 20 mm. The equipment and procedure used shall be in accordance with ISO 2505.

8.8 Vicat softening temperature

This test consists of immersing segments of rings removed from the pipes, having a length of approximately 50 mm, a width of between 10 mm and 20 mm and a thickness of between 2,4 mm and 6 mm, in a heating bath containing a suitable liquid. Then determine the temperature at which a standard indenter penetrates 1 mm + 0,01 mm into the test piece (see Figure 1). The equipment and procedure used shall be in accordance with ISO 2507-1 and ISO 2507-2.

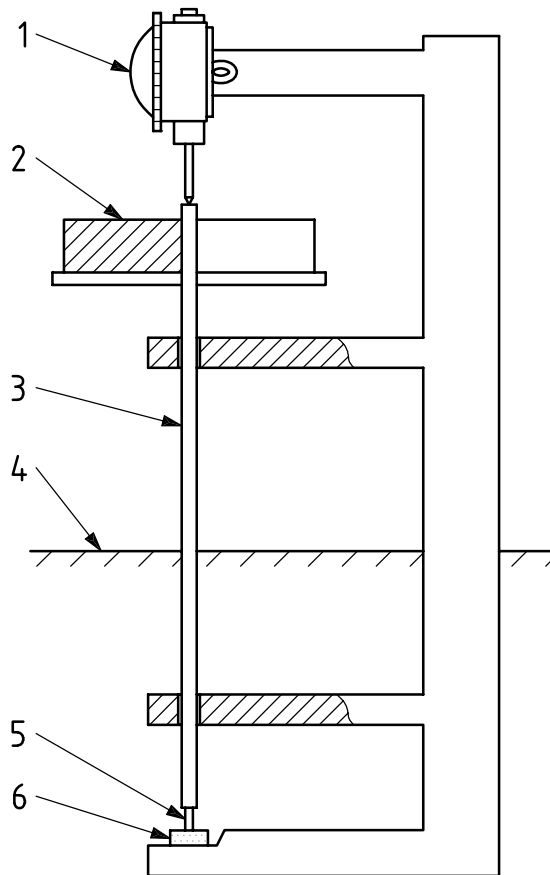

Key

- 1 dial gauge micrometer
- 2 interchangeable weight
- 3 assembly of rod and indenting tip supporting the load-carrying plate
- 4 approx. level of liquid
- 5 indenting tip
- 6 test specimen

Figure 1 — Equipment and location of test specimen for Vicat softening temperature test

8.9 Flow rate of gates

Measure the flow rate in the first and the last gates of the lateral pipe, following the manufacturer's recommendations for pressure and degree of gate opening, as well as for any other parameters that the manufacturer considers necessary.

Bibliography

- [1] ISO 3126, *Plastics pipes — Measurement of dimensions*
- [2] ISO 3951, *Sampling procedures and charts for inspection by variables for percent nonconforming*
- [3] NMX-E-234-SCFI-2001, *Plastic industry — PVC piping — Unplasticized polyvinyl chloride (PVC) pipes for irrigation low-pressure water supply with gates — Specifications* ¹⁾
- [4] ASTM²⁾ G 53, *Standard Test Method for Operating Light-Exposure and Water-Exposure Apparatus (Fluorescent UV-Condensation-Type) for Nonmetallic Materials*
- [5] ASTM D 2441-89, *Standard Test Method for Polyvinyl Chloride (PVC) Pressure-Rated Pipe*
- [6] ASTM D 2444-99, *Standard Test Method for Impact Resistance of Thermoplastic Pipe and Fittings by Means of a Tup (Falling Weight)*

1) Mexican Standard (NMX).

2) American Society for Testing and Materials.

ICS 65.060.35

Price based on 8 pages