

---

---

**Ships and marine technology — Protective  
coatings and inspection method —**

**Part 3:  
Cargo oil tanks of crude oil tankers**

*Navires et technologie maritime — Revêtements de protection et  
méthode d'inspection —*

*Partie 3: Réservoirs d'huile de chargement de réservoirs de pétrole brut*



Reference number  
ISO 16145-3:2012(E)

© ISO 2012

.....



## COPYRIGHT PROTECTED DOCUMENT

© ISO 2012

All rights reserved. Unless otherwise specified, no part of this publication may be reproduced or utilized in any form or by any means, electronic or mechanical, including photocopying and microfilm, without permission in writing from either ISO at the address below or ISO's member body in the country of the requester.

ISO copyright office  
Case postale 56 • CH-1211 Geneva 20  
Tel. + 41 22 749 01 11  
Fax + 41 22 749 09 47  
E-mail [copyright@iso.org](mailto:copyright@iso.org)  
Web [www.iso.org](http://www.iso.org)

Published in Switzerland

# Contents

Page

<b>Foreword</b> .....	<b>iv</b>
<b>Introduction</b> .....	<b>v</b>
<b>1 Scope</b> .....	<b>1</b>
<b>2 Normative references</b> .....	<b>1</b>
<b>3 Terms and definitions</b> .....	<b>2</b>
<b>4 Symbols and abbreviated terms</b> .....	<b>3</b>
<b>4.1 Symbols</b> .....	<b>3</b>
<b>4.2 Abbreviated terms</b> .....	<b>3</b>
<b>5 General procedures for coating work</b> .....	<b>3</b>
<b>6 Standard for coating work</b> .....	<b>4</b>
<b>6.1 Areas considered</b> .....	<b>4</b>
<b>6.2 Surface preparation</b> .....	<b>6</b>
<b>6.3 Primary surface preparation and shop priming</b> .....	<b>7</b>
<b>6.4 Secondary surface preparation</b> .....	<b>9</b>
<b>6.5 Coating</b> .....	<b>10</b>
<b>6.6 Treatment for coating defects</b> .....	<b>13</b>
<b>7 Inspection</b> .....	<b>14</b>
<b>7.1 Inspection procedure</b> .....	<b>14</b>
<b>7.2 Coating inspection</b> .....	<b>14</b>
<b>7.3 Dry film thickness measurement</b> .....	<b>16</b>
<b>Annex A (informative) Measurement of the conductivity for abrasives</b> .....	<b>21</b>
<b>Annex B (informative) Measurement of water soluble salt</b> .....	<b>23</b>
<b>Annex C (informative) Inspection items and management of inspection</b> .....	<b>25</b>
<b>Annex D (informative) Assessment of the degree of damage</b> .....	<b>30</b>
<b>Annex E (informative) Standard for coating technical file (CTF)</b> .....	<b>31</b>
<b>Bibliography</b> .....	<b>40</b>

## Foreword

ISO (the International Organization for Standardization) is a worldwide federation of national standards bodies (ISO member bodies). The work of preparing International Standards is normally carried out through ISO technical committees. Each member body interested in a subject for which a technical committee has been established has the right to be represented on that committee. International organizations, governmental and non-governmental, in liaison with ISO, also take part in the work. ISO collaborates closely with the International Electrotechnical Commission (IEC) on all matters of electrotechnical standardization.

International Standards are drafted in accordance with the rules given in the ISO/IEC Directives, Part 2.

The main task of technical committees is to prepare International Standards. Draft International Standards adopted by the technical committees are circulated to the member bodies for voting. Publication as an International Standard requires approval by at least 75 % of the member bodies casting a vote.

Attention is drawn to the possibility that some of the elements of this document may be the subject of patent rights. ISO shall not be held responsible for identifying any or all such patent rights.

ISO 16145-3 was prepared by Technical Committee ISO/TC 8, *Ships and marine technology*, Subcommittee SC 8, *Ship design*.

ISO 16145 consists of the following parts, under the general title *Ships and marine technology — Protective coatings and inspection method*:

- *Part 1: Dedicated sea water ballast tanks*
- *Part 2: Void spaces of bulk carriers and oil tankers*
- *Part 3: Cargo oil tanks of crude oil tankers*

The following parts are under preparation:

- *Part 4: Automated measuring method for the total amount of water-soluble salts*
- *Part 5: Assessment method for coating damages*

## Introduction

The ISO 16145 series addresses qualified coating and inspection works in accordance with the requirements of IMO PSPC.

Technical Committee ISO/TC 8, *Ships and marine technology*, SC 8, *Ship design* has decided to standardize a coating and inspection method for the IMO PSPC series.

Coating quality itself depends largely on the surface preparation and coating application. Therefore, the right application of surface preparation and coating in accordance with coating manufacturer's recommendations including inspections at each step are of vital importance.

This part of ISO 16145 is intended to serve as a standard for ship owners, shipyards, coating manufacturers, coating inspectors and coating applicators in applying IMO PSPC in the new building stage.



# Ships and marine technology — Protective coatings and inspection method —

## Part 3: Cargo oil tanks of crude oil tankers

### 1 Scope

This part of ISO 16145 specifies a method of protective coatings and its inspection of cargo oil tanks for crude oil tankers of not less than 5 000 tonnes deadweight, which are contracted for new building on or after 1 January 2013; or in the absence of a building contract, the keels of which are laid or which are at a similar stage of construction on or after 1 July 2013; or the delivery of which is on or after 1 January 2016.

**NOTE** A crude oil tanker is an oil tanker engaged in the trade of carrying crude oil. This part of ISO 16145 applies to crude oil tankers and crude oil/product carriers as defined in items 1.11.1 or 1.11.4 of the Supplement to the International Oil Pollution Prevention Certificate (Form B).

### 2 Normative references

The following documents, in whole or in part, are normatively referenced in this document and are indispensable for its application. For dated references, only the edition cited applies. For undated references, the latest edition of the referenced document (including any amendments) applies.

ISO 8501-1:2007, *Preparation of steel substrates before application of paints and related products — Visual assessment of surface cleanliness — Part 1: Rust grades and preparation grades of uncoated steel substrates and of steel substrates after overall removal of previous coatings*

ISO 8501-3:2001<sup>1)</sup>, *Preparation of steel substrates before application of paints and related products — Visual assessment of surface cleanliness — Part 3: Preparation grades of welds, cut edges and other areas with surface imperfections*

ISO 8502-3:1992, *Preparation of steel substrates before application of paints and related products — Tests for the assessment of surface cleanliness — Part 3: Assessment of dust on steel surfaces prepared for painting (pressure-sensitive tape method)*

ISO 8502-9:1998, *Preparation of steel substrates before application of paints and related products — Tests for the assessment of surface cleanliness — Part 9: Field method for the conductometric determination of water-soluble salts*

ISO 8503-1:2012, *Preparation of steel substrates before application of paints and related products — Surface roughness characteristics of blast-cleaned steel substrates — Part 1: Specifications and definitions for ISO surface profile comparators for the assessment of abrasive*

ISO 8503-2:2012, *Preparation of steel substrates before application of paints and related products — Surface roughness characteristics of blast-cleaned steel substrates — Part 2: Method for the grading of surface profile of abrasive blast-cleaned steel — Comparator procedure*

IACS UI SC223, *For Application of SOLAS Regulation II-1/3-2 Performance Standard for Protective Coatings (PSPC) for Dedicated Seawater Ballast Tanks in All Types of Ships and Double-side Skin Spaces of Bulk Carriers, adopted by Resolution MSC.215 (82)*

IMO Res.MSC.288 (87), *Performance standard for protective coatings for cargo oil tanks of crude oil tankers*

1) Withdrawn International Standard revised by ISO 8501-3:2006.

### 3 Terms and definitions

For the purposes of this document, the following terms and definitions apply.

#### 3.1

##### **90/10 rule**

rule according to which 90% of all thickness measurements should be greater than or equal to nominal dry film thickness (NDFT) and none of the remaining 10% measurements shall be below 90% of NDFT

#### 3.2

##### **abrasive**

metallic or non-metallic particles which are used in blasting work for removing mill scale, rust or foreign substance on the surface to be coated using pressurized air or a high-speed rotating impeller

NOTE A steel shot ball is used mainly in the primary surface preparation and steel grit is used mainly in the secondary surface preparation; however, garnet or non-metallic abrasives may be used in some circumstances.

#### 3.3

##### **coating inspector**

qualified person certified to at least NACE Coating Inspector Level 2, FROSIO Inspector Level III, or an equivalent qualification with at least two years' documented relevant coating inspection experience and as agreed by ship owner, shipyard and coating manufacturer as specified in IACS UI SC223, adopted by Resolution MSC.215 (82)

#### 3.4

##### **erection**

final assembly of blocks or pre-erected blocks

EXAMPLE On the dry dock or ground building berth.

#### 3.5

##### **line quality controller**

##### **line QC**

person, other than the coating inspector or assistant to the coating inspector, who carries out the inspection work prior to the official inspection

#### 3.6

##### **measurement of representative dry film thickness (DFT)**

measurement of typical dry film thickness (DFT) after each main coating in order to use it as a reference in a follow-up coating by measuring the film thickness of certain representative parts of the compartment

NOTE It is not necessary to keep a record of the representative DFT.

#### 3.7

##### **pre-erection**

assembly of blocks in large units corresponding to the crane capacity for erection

#### 3.8

##### **shop primer**

prefabrication primer coating applied to steel plates, often in automatic plants (and before the first coat of a coating system)

#### 3.9

##### **stain**

light shadows, slight streaks or minor discolorations



## 4 Symbols and abbreviated terms

### 4.1 Symbols

$C_m$	electric conductivity of solutions
$C_s$	electric conductivity of abrasive
$K$	cell constant

### 4.2 Abbreviated terms

CTF	coating technical file
DFT	dry film thickness
FROSIO	Faglig Råd for Opplæring og Sertifisering av Inspektører innen Overflatebehandling (The Norwegian Professional Council for Education and Certification of Inspectors for Surface Treatment)
IACS	International Association of Classification Societies Ltd
IMO	International Maritime Organization
JSRA-SPSS	The Shipbuilding Research Association of Japan - Standard for the preparation of steel surface prior to painting
JSTRA SPSS for PSPC	Japan Ship Technology Research Association - Standard for the preparation of steel substrate for PSPC (SPSS for PSPC)
NACE	NACE International
NDFT	nominal dry film thickness
PSPC	performance standard for protective coatings
QA	quality assurance
QC	quality control
SOC	statement of compliance
SSPC	The Society for Protective Coatings (former Steel Structure Painting Council, USA)
TAC	type approval certificate
COT	cargo oil tank

## 5 General procedures for coating work

The typical hull construction process for coating is listed in Table 1 below.

Table 1 — Typical coating and inspection steps for hull structure

Step	Item	Description
1	Storage of steel	Storage area for plates and profiles.
2	Primary surface preparation (pre-treatment) and shop priming	Remove mill scale, rust, and other contaminants and apply shop primer. Details are given in 6.2.
3	Inspection for primary surface preparation and shop priming	Carry out a self-inspection in accordance with the QA system. The QA system contains a regular check and record of surface cleanliness, surface profile, DFT measurement, salt measurement, etc.
4	Steel cutting	Cut steel for assembly.
5	Sub-assembly	Primary assembly step on a small or medium scale. Carry out the work including edge preparation in accordance with ISO 8501-3:2001 (P2 grade). Details are given in 6.3.3 for edge preparation.
6	Block assembly or unit and panel assembly	A step of assembling the members assembled in a small or medium scale into block unit. Carry out the work including edge preparation in accordance with ISO 8501-3:2001 (P2 grade). Details are given in 6.3.3 for edge preparation.
7	Pre-outfitting	Install outfits such as pipes and supports prior to block coating.
8	Secondary surface preparation (block stage)	Details are given in 6.4 for the secondary surface preparation for completed block.
9	Inspection for secondary surface preparation (block stage)	Inspection by a coating inspector (or an assistant to coating inspector under direct supervision of the coating inspector).
10	Block coating	Details are given in 6.5 for the step of coating on the block where surface preparation and inspection are completed.
11	Inspection for block coating	Inspection by a coating inspector (or an assistant to coating inspector under direct supervision of the coating inspector).
12	Pre-erection	Assemble blocks in large units corresponding to the crane capacity for erection.
13	Secondary surface preparation and coating for pre-erection joint	Details are given in 6.4 and 6.5 for surface preparation and coating work of the welding joint of pre-erection.
14	Inspection for pre-erection joint	Inspection by a coating inspector (or an assistant to coating inspector under direct supervision of the coating inspector).
15	Erection	Final assembly step of blocks or pre-erected blocks on the dry dock or ground building berth.
16	Secondary surface preparation and coating for erection joint	Details are given in 6.4 and 6.5 for the step of secondary surface preparation and coating work on erection joint.
17	Inspection erection joint	Inspection by a coating inspector (or an assistant to coating inspector under direct supervision of the coating inspector).
18	Completion	Completion and final coating touch up and repair.

Steps 12 to 14 may be omitted depending on the size of blocks and the conditions of each shipyard.

## 6 Standard for coating work

### 6.1 Areas considered

The following areas are the minimum areas that shall be coated according to IMO Res.MSC.288 (87). See Figure 1.

- a) Deckhead with complete internal structure, including brackets connecting to longitudinal and transverse bulkheads. In tanks with ring frame girder construction, the under deck transverse framing shall be coated down to the level of the first tripping bracket below the upper faceplate.

- b) Longitudinal and transverse bulkheads shall be coated to the uppermost means of access level. The uppermost means of access and its supporting brackets shall be fully coated.
- c) On cargo tank bulkheads without an uppermost means of access the coating shall extend to 10 % of the height of the tank at centre line but need not extend more than 3 m down from the deck.
- d) The flat inner bottom and all structures to a height of 0,3 m above the inner bottom shall be coated.

Dimensions in millimetres

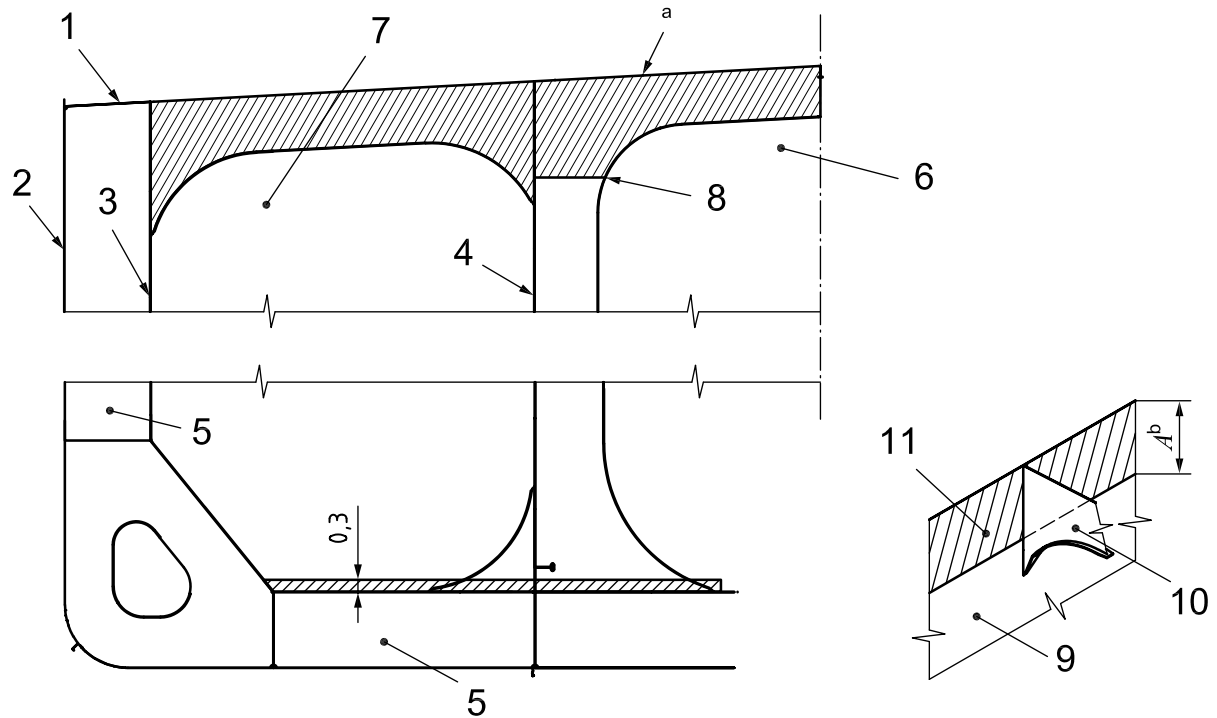

**Key**

- 1 upper deck
- 2 side shell
- 3 outer longitudinal bulkhead
- 4 inner longitudinal bulkhead
- 5 water ballast tank
- 6 centre cargo oil tank
- 7 side cargo oil tank
- 8 first tripping bracket
- 9 bulkhead plate
- 10 web frame
- 11 detail of bulkhead connection
- a The oblique lined part shows the area that shall be coated at a minimum.
- b Dimension "A" shall be from uppermost PMA height to upper deck height.

**Figure 1 — Midship section of VLCC**

## 6.2 Surface preparation

### 6.2.1 Applicable standard

#### 6.2.1.1 Grade of surface cleanliness

For further details including picture, see ISO 8501-1:2007 and ISO 8501-1:1988/Suppl:1994.

a) Sa 2 (thorough blast cleaning)

When viewed without magnification, the surface shall be free from visible oil, grease and dirt, and most of the mill scale, rust, paint coatings and foreign matter. Any remaining contamination shall be attached solidly.

b) Sa 2½ (very thorough blast cleaning)

When viewed without magnification, the surface shall be free from visible oil, grease and dirt, as well as mill scale, rust, paint coatings and foreign matter. Any remaining traces of contamination shall show only as slight stains in the form of spots or stripes.

c) St 2 (thorough hand and power tool cleaning)

When viewed without magnification, the surface shall be free from visible oil, grease and dirt, as well as poorly adhering mill scale, rust, paint coatings and foreign matter.

d) St 3 (very thorough hand and power tool cleaning)

As for St 2, the surface shall be treated much more thoroughly to give a metallic shine arising from the metallic substrate.

#### 6.2.1.2 Comparison with other standards

Comparison of the grade of surface preparation with other standards is shown in Table 2.

**Table 2 — Comparison of the grade of surface preparation with other standards**

ISO 8501-1:2007	SIS 05 59 00	SSPC-Vis 1/Vis 3	NACE
Sa 2	Sa 2	SSPC-SP 6	NACE No. 3
Sa 2½	Sa 2½	SSPC-SP 10	NACE No. 2
St 2	St 2	SSPC-SP 2	—
St 3	St 3	SSPC-SP 3	—

#### 6.2.1.3 Inspection of surface preparation

The prepared surface shall be inspected as follows.

- a) Examine the condition of steel surface visually immediately before coating application and compare to the surface preparation photographs in ISO 8501-1:2007.
- b) A rational decision shall be made after considering the following fully:
  - 1) The object to be coated is much larger and has a more complex shape than the photographs in ISO 8501-1:2007.
  - 2) Stains are allowed up to 5 % for Sa 2½ and up to 30 % for Sa 2.
  - 3) The surface to be inspected may be different than the pictures in ISO 8501-1:2007 because the final prepared surface colour is dependent on lighting, type and size of blast material and initial steel surface grade.

## 6.2.2 Reference to the secondary surface preparation

**6.2.2.1** Internationally recognized standards such as ISO 8501-1:2007, SSPC-Vis 1 or SSPC-Vis 3 shall be used for the inspection of surface preparation. The JSRA/JSTRA standard may be used for inspection of secondary surface preparation.

NOTE The JSRA/JSTRA standard may be referred to for information that is not contained in the standard for secondary surface preparation of ISO 8501-1:2007.

**6.2.2.2** Table 3 shall be used as a reference for comparison of ISO international standards and JSRA/JSTRA standards.

**Table 3 — Comparison between ISO international standards and JSRA/JSTRA standards**

Method of preparation	ISO 8501-1:2007	JSRA-SPSS	JSTRA standard (SPSS for PSPC)
Blast cleaning	B Sa 1, C Sa 1	(IH, IA, IF, ID, IR) Ss	—
	B Sa 2	(IH, IA, IF, ID, IR) Sd1	—
	B Sa 2½	(IH, IA, IF, ID, IR) Sd2	Sa 2½, Rec
	B Sa 3	(IH, IA, IF, ID, IR) Sd3	—
Hand tool or power tool cleaning	—	(IH, IA, IF, ID, IR) Pt1	—
	B St 2, C St 2	(IH, IA, IF, ID, IR) Pt2	—
	B St 3, C St 3	(IH, IA, IF, ID, IR) Pt3	St 3, Rec

## 6.3 Primary surface preparation and shop priming

### 6.3.1 Primary surface preparation

**6.3.1.1** The steel plates and profiles of the hull to be coated shall be blasted to the grade of Sa 2½ with the surface roughness of between 30 µm and 75 µm [Medium (G) or Medium (S)]. The measurement (and decision) of surface roughness shall be done in accordance with ISO 8503-1:2012 and ISO 8503-2:2012.

**6.3.1.2** In the event that the relative humidity in the blasting chamber (cell) is higher than 85 % or the temperature of steel surface is lower than 3 °C above the dew point, blasting work shall not be carried out.

**6.3.1.3** After surface preparation, the cleanliness of the steel surface and surface roughness shall be inspected prior to applying shop primer in accordance with the recommendations of the coating manufacturer.

**6.3.1.4** The requirements for the inspection of primary surface preparation shall be a periodic spot check at least once per month normally, in the event that the following conditions are met and such a procedure is documented:

- a) Primary surface preparation is to be carried out in the facility in which the environment and quality level are not substantially changed.

NOTE Substantially changed means an environment change under the level mentioned in 6.3.1.2.

- b) Primary surface preparation and coating work are done automatically.
- c) Shop primer is coated immediately after the surface preparation.
- d) Steel surface condition is unchanged.

**6.3.1.5** Considering contamination from foreign substances, an allowable water soluble salt level of abrasive shall be controlled through a QA system so that it maintains the conductivity of 250 µS/cm or less. See Annex A for measurement of conductivity using ISO 11127-6.

6.3.1.6 The allowable water soluble salt content on the surface shall be lower than 50 mg/m<sup>2</sup>, and the measurement shall be done in accordance with ISO 8502-9:1998 or NACE SP0508-2010. See Annex B for measurement of water soluble salt according to ISO 8502-9:1998.

6.3.1.7 Type approved shop primer shall be used in accordance with the recommendation of the coating manufacturer.

### 6.3.2 Shop priming

6.3.2.1 One coat of inorganic zinc silicate shop primer or another type of approved shop primer as an alternative system shall be applied on the steel surface with the dry film thickness recommended by the coating manufacturer immediately after primary surface preparation for the purpose of prevention of regeneration of rust.

6.3.2.2 Compatibility of the shop primer with the main coating system shall be confirmed by the coating manufacturer. If compatibility with the main coating system is not proven, the shop primer shall be prepared to Sa 2 ensuring that at least 70 % of the shop primer is removed.

6.3.2.3 The coating system shall comply with TAC and SOC requirements.

### 6.3.3 Steel condition

6.3.3.1 Edges shall be treated in a minimum radius of 2 mm, or three pass grindings or at least an equivalent process to three pass grindings. See Figure 2 for three pass grindings.

NOTE "Equivalent process" is a process that produces an edge profile geometrically equivalent to, or better than that usually obtained by three pass grindings which results in an effective coating performance.

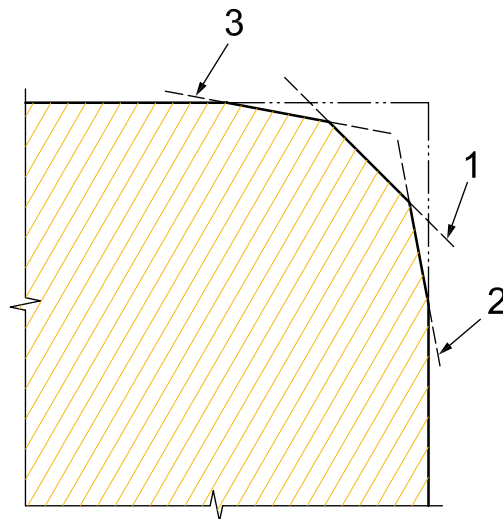

#### Key

- 1 first pass grinding
- 2 second (or third) pass grinding
- 3 third (or second) pass grinding

Figure 2 — Diagram for three pass grindings

## 6.4 Secondary surface preparation

### 6.4.1 General

**6.4.1.1** The JSRA/JSTRA standard is recommended as a supplemental standard to ISO 8501-1:2007.

**6.4.1.2** Fumes occurring while welding and cutting shall be properly treated in accordance with the recommendation of the coating manufacturer.

**6.4.1.3** Spatters around the welding line shall be removed. However, spatters which have obtuse angles and which are stuck firmly to the surface shall be left as is in accordance with ISO 8501-3:2001 (P2 grade).

**6.4.1.4** A defect such as a blowhole on a welding bead may be filled with putty if re-welding is not necessary and the putty shall be compatible with the main coating system confirmed by the coating manufacturer.

**6.4.1.5** The surface of the cutting edge, welding bead and the damaged part may be shop coated with a standard primer of the shipyard up to the possible range in accordance with the convenience of the shipyard or fabricator.

### 6.4.2 Secondary surface preparation in the block assembly step

**6.4.2.1** The damaged shop primer and welding bead including the area mentioned in 6.4.1.5 shall be blasted to the grade of Sa 2 ½.

NOTE “Damaged shop primer” is the area in which the condition of the shop primer, in the opinion of the coating inspector or coating manufacturer of the main coating system, will result in reduced performance of the main coating system. For example, it is possible to suggest a fire damaged part or a rusted part.

**6.4.2.2** Contaminants such as zinc salt remaining on the retained shop primer shall be removed in a method such as disc sweeping or sweep blasting as recommended by the coating manufacturer.

**6.4.2.3** The surface roughness shall be between 30 µm and 75 µm [Medium (G) or Medium (S)] if full or partial blasting, and the measurement (and decision) shall be done in accordance with ISO 8503-1:2012 and ISO 8503-2:2012.

NOTE Full or partial blasting is the blasting work carried out on the damaged primer part and welding line described in 6.4.2.1. Sweep blasting for simple cleaning purposes does not correspond to this, and the roughness of the surface is in accordance with the recommendation of the coating manufacturer.

**6.4.2.4** St 3 may be accepted for surface treatment to rectify small and insufficiently treated areas after blasting.

**6.4.2.5** Water-soluble salts shall be measured in at least one location per block after the surface preparation, and the allowable water soluble salt level shall be lower than 50 mg/m<sup>2</sup>, and the measurement shall be based on ISO 8502-9:1998 or NACE SP0508-2010. See Annex B for measurement of water soluble salt according to ISO 8502-9:1998.

### 6.4.3 Secondary surface preparation in the pre-erection and erection step (surface preparation after erection)

**6.4.3.1** The surface of the pre-erection and erection joints shall be treated to St 3 or better or to Sa 2½ if possible.

**6.4.3.2** The damaged part shall be treated to St 3 grade if the coating damage is less than 2 % of the total area of the tank. However, contiguous damages more than 25 m<sup>2</sup> or a damaged area of more than 2 % of the total area of the tank shall be blasted to the grade of Sa 2 ½. See Annex D for assessment of the damages.

NOTE The term damage means that the damage has reached the steel surface.



**6.4.3.3** The damaged part of bottom parts shall be treated to St 3 grade if the coating damage is less than 20 % of the area to be coated. However, contiguous damages more than 25 m<sup>2</sup> or a damaged area of more than 20 % of area to be coated shall be treated to Sa 2½. See Annex D for assessment of the damages.

**6.4.3.4** The defects remaining between the layers of film shall be repaired in accordance with the recommendation of the coating manufacturer. Such kinds of defects, pre-erection joint, erection joint and damage in the vicinity of pre-erection and erection joint shall be excluded in the calculation of 3 % or 20 % and contiguous 25 m<sup>2</sup> in 6.4.3.2 and 6.4.3.3.

**6.4.3.5** Usually, the fillet welding on the tank boundary watertight bulkhead is left without coating in the block stage (because leakage test has not yet been carried out), in which case it can be categorized as an erection joint (“butt”) to be handled by power tooling to St 3 and excluded in the calculation of 3 % or 20 % and contiguous 25 m<sup>2</sup> in 6.4.3.2 and 6.4.3.3.

**NOTE** The use of a type of approved zinc silicate shop primer over blasted weld lines is masked by tape before block painting. The masking tape is removed after block painting or before pressure testing. Simply washing and drying the zinc shop primer coated weld lines before over coating could reduce power tool cleaning later.

**6.4.3.6** Coating in overlap shall be treated in accordance with the coating manufacturer’s recommendation. Compatibility between main coatings shall be confirmed by the coating manufacturer when a certified main coating inevitably contacts or overlaps with another type of certified main coating, e.g. partial re-coating of damaged part and coating nearby butts, where different seasonal type of coatings have to be applied due to changes in environmental conditions.

**6.4.3.7** Inspection for confirming suitable conditions for the erection joint, including the pre-erection joint, prior to coating may be limited to visual inspection at the coating inspector’s discretion.

## 6.5 Coating

### 6.5.1 Cleaning prior to coating

**6.5.1.1** Moisture shall be removed until it becomes invisible to the naked eye.

**6.5.1.2** Oil components (oil and grease) shall be properly removed by using solvent, etc. in accordance with SSPC SP1 or the recommendation of the coating manufacturer; however, the stains may remain.

**6.5.1.3** Contaminants such as dust or dirt shall be removed from the surface by an appropriate method such as compressed air or a vacuum cleaner, dust cloth, broom, etc.

Visual inspection shall be carried out for inspection of dust after surface preparation and cleaning, and the tape test (in accordance with ISO 8502-3:1992) may be omitted if the related inspector(s) agrees.

The dust quantity rating of “1” is applied to the dust size class of “3”, “4” and “5”, and the dust of smaller size, which is limited to the dust visible to the naked eye without a magnifier or other subsidiary instrument, shall be removed from the surface.

Dust of small size less than the dust size class of “3” is not visible to the naked eye unless it accumulates in large quantities. The dust of small size accumulated together, which is visible to the naked eye, shall be removed until it is no longer visible.

The dust which exceeds the dust quantity rating of “1” (for the dust size class of “3”, “4” and “5”), shall be corrected (removed) to the level that satisfies the coating inspector.

**6.5.1.4** A marking pen recommended by the coating manufacturer is used and the marking is not removed.



## 6.5.2 Coating work

### 6.5.2.1 Main coating work

**6.5.2.1.1** An airless spray is generally used, and a brush or roller may be used for areas where it is more suitable than airless spray.

**6.5.2.1.2** Intervals for re-coating, and factors such as the mixing ratio, etc. shall be based on the recommendation of the coating manufacturer.

**6.5.2.1.3** Coating work shall not be done when the relative humidity is higher than 85 % or the temperature of the steel plate is less than 3 °C above the dew point.

**6.5.2.1.4** Discoloration and/or colour difference due to the different place and time of application and aging of paint, which does not affect the quality and performance of coating, should be confirmed by the coating manufacturer and may be left without further treatment.

**6.5.2.1.5** The damaged part of the galvanized material can be coated for repair with one coat of zinc-rich primer or the same coating specification as surroundings or equivalent in accordance with the recommendation of the coating manufacturer.

**6.5.2.1.6** A coating worker shall measure the wet film thickness (WFT) regularly in order to achieve the specified dry film thickness.

**6.5.2.1.7** Representative dry film thickness shall be measured after each main coating for the guideline of final coating. In that case, the provision of 7.3 is not applied.

**6.5.2.1.8** The total dry film thickness shall be confirmed after final coating in accordance with the provision of 7.3.

**6.5.2.1.9** Nominal dry film thickness (NDFT) shall be 320 µm, and the 90/10 rule shall be applied.

**6.5.2.1.10** The maximum total dry film thickness shall be based on the detailed guidelines of the coating manufacturer, and attention shall be paid so that excessive film thickness does not occur.

**6.5.2.1.11** Any use of thinners shall be in accordance with the recommendation of the coating manufacturer.

**6.5.2.1.12** Light colour shall be used in the final coating in order to make it easier to conduct an inspection during operation.

**NOTE** Light colour is a colour that reflects light to an extent that a simple flashlight (hand torch) makes inspection easy and fast. Usually, light grey, buff, off-white, swimming pool blue/green, etc. are easily distinguishable from rust.

### 6.5.2.2 Stripe coating

**6.5.2.2.1** A stripe coating is a coating that is applied so as not to leave an uncoated part or give the dry film thickness and ensure good adhesion in the weak part such as edges, welds, and parts which are difficult to access.

**6.5.2.2.2** A stripe coating shall be done by using brush, roller or an equivalent method. A roller may be used for scallops, rat holes, etc., but not for edges and welds.

**6.5.2.2.3** A stripe coating with a minimum of two coats is required in the welding bead and edge part, and one coat (first or second) of stripe coating may be omitted in order to avoid excessive dry film thickness on the welding bead if the nominal dry film thickness (NDFT) is satisfied. One coat (first or second) of stripe coating omitted shall be described in detail in the coating technical file (CTF).

NOTE A CTF is a document set covering the specification applied in the coating system, a record relating to the coating work of shipyard and ship owner, a detailed standard for selecting the coating system, specification, inspection, maintenance and repair. It is drafted by each inspection party and collected by the shipyard and submitted to the administration for review. See Annex E for details on the CTF.

6.5.2.2.4 The dry film thickness within 15 mm from the welding bead shall be measured in order to omit one coat (first or second) of stripe coating, and the verification of nominal dry film thickness (NDFT) is carried out in the method of measuring flat plate based on the statistical sampling method as described in 7.3.

The decision whether to omit the first or the second stripe coating shall be done by the coating inspector under the condition that the nominal dry film thickness (NDFT) is satisfied.

NOTE Example of statistical sampling: measurement is done in 30 points per block.

6.5.2.2.5 The colour of stripe coating can be decided by the shipyard in accordance with the recommendation of the coating manufacturer.

6.5.2.2.6 General stripe coating standards for each part are shown in Table 4.

Table 4 — Stripe coating standards for each part

Item		Treatment	Part to be applied		No.	Execution	Remarks
Edge part	Edge cut with flame	By grinding	End part of hole	Small hole	①	After (or before) first coat and second coat (or final coat)	
				Big hole	②		
			Free edge	Collar plate	③		
				Support member	④		
		By rolling equipment	Built-up section		⑤		
	Rolled edge	By rolling equipment	Section steel (section and flat bar)		⑥		
Welding bead	Automatic welding, semi-automatic welding	By welding machine or equipment	Joint part of transverse/longitudinal strength member and flat plate		⑦	After (or before) first coat or second coat (or final coat)	Stripe coating of two coats if nominal dry film thickness (NDFT) is not enough
	Manual welding	Manually	Joint part of collar plate		⑧		
			Joint part of small stiffener		⑨		
NOTE See Figure 3 for numbers (① to ⑨).							

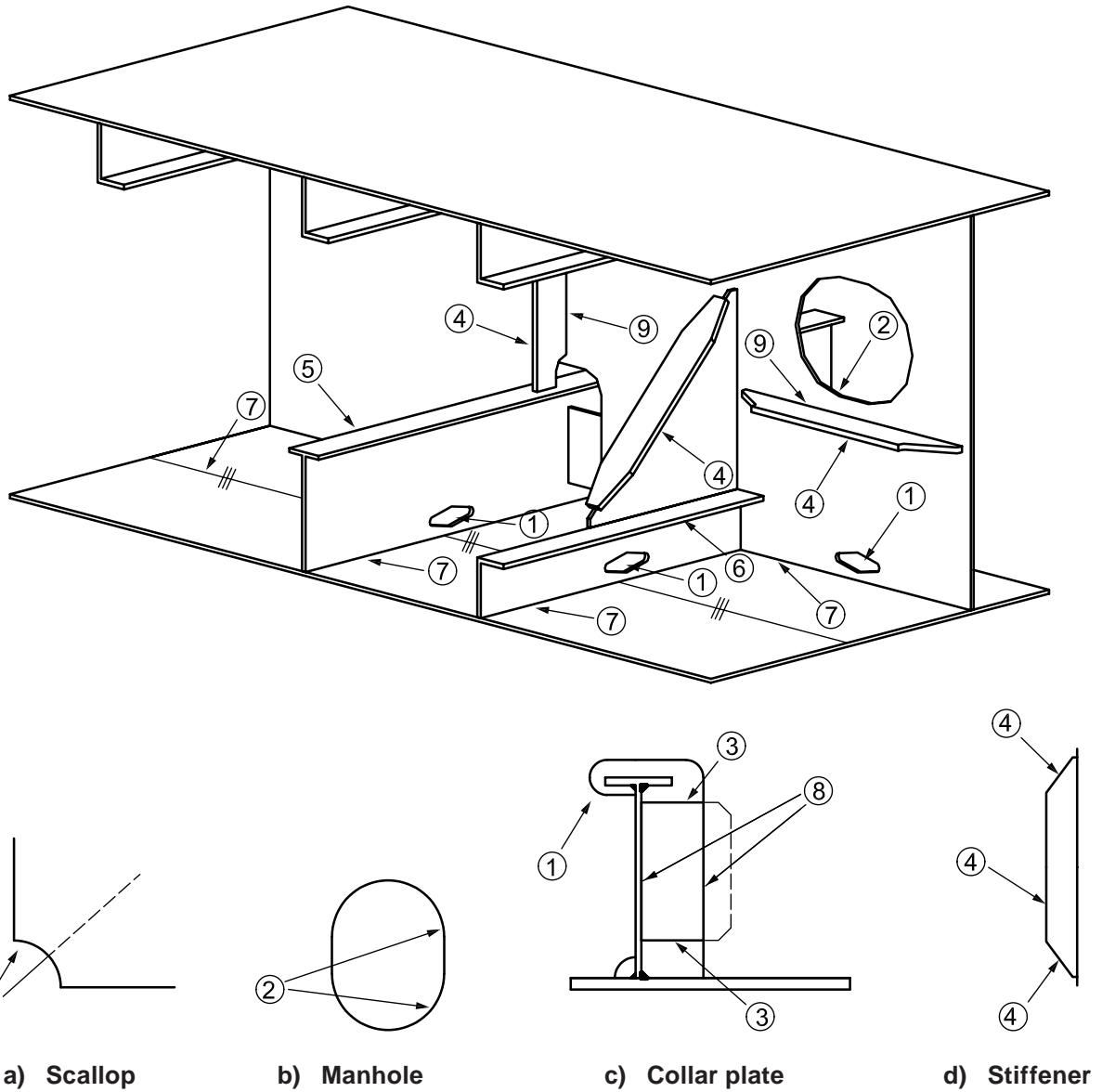

Figure 3 — Detail of stripe coating for each part

## 6.6 Treatment for coating defects

The coating defect which the coating inspector deems in need of repair during the coating work is based on Table 5. The details follow the ordinary practice of the shipyard and the recommendation of the coating manufacturer.

**Table 5 — Correction method for each coating defect**

Kind of defect	Method of treatment
Blushing	1) Leave it as it is if the blushing is minute or occurs in the limited part. 2) Remove it with thinner in the part in need of repair where it occurred before carrying out the succeeding coating. Then carry out the succeeding coating. 3) Leave it as it is if it occurs on the surface after coating is finished.
Pinholes	1) Remove it with a hand tool or power tool (light pinholes are not necessary to remove but treated by paper and touch up coating to be done). 2) Coat in accordance with the original coating specification after treating the surface.
Bubbles	1) Remove it with a scraper etc. 2) Coat in accordance with the original coating specification after treating the surface.
Voids	1) Remove foreign substances, e.g. rust. 2) Coat in accordance with the original coating specification.

## 7 Inspection

### 7.1 Inspection procedure

**7.1.1** Inspection procedure for surface preparation and coating shall be agreed upon among the ship owner, shipyard and coating manufacturer and presented to the administration (classification society) for review. It is possible to make a request for the administration to participate in the above process of agreement. Clear evidence materials for such inspections shall be included in the coating technical file (CTF) and submitted to the administration (for verification).

**7.1.2** Inspection shall be carried out by the coating inspector(s) certified at a minimum to NACE Coating Inspector Level 2, FROSIO Inspector Level III or equivalent as specified in IACS UI SC223, 6.1 interpretations and verified by the administration.

**7.1.3** Selection of the coating inspector is regarded as a part of the matter for agreement in 7.1.1.

**7.1.4** The coating inspector may appoint an assistant to coating inspector to carry out a part of the inspection under the coating inspector's supervision.

**7.1.5** The coating inspector shall confirm at least the items described in this part of ISO 16145 during the surface preparation and coating process. The confirmation of dry film thickness shall be done by non-destructive inspection methods.

**7.1.6** If the coating inspectors require additional tests, measurement and inspection above the requirement of the agreed inspection specification, the inspector shall have a clear reason but he has the right to do so.

**7.1.7** Inspection results shall be recorded and verified, and shall be collected in the CTF.

### 7.2 Coating inspection

#### 7.2.1 General

The coating inspector shall inspect the surface preparation and coating work in accordance with Annex C.

## 7.2.2 Attendance of inspection

The shipyard or fabricator shall give the coating inspector a notice for the inspection schedule for the items to be inspected. The results of inspection shall be recorded on the inspection report including some notes, if any.

## 7.2.3 Notice of inspection

**7.2.3.1** The shipyard or fabricator shall make an inspection notice prior to starting inspection if the inspection is on the schedule.

**7.2.3.2** The shipyard or fabricator shall make a notice, after readjusting the inspection plan, if the inspection item is cancelled or added by the shipyard or fabricator due to an urgent situation considering the characteristics of the coating work.

**7.2.3.3** The shipyard or fabricator shall make an effort to carry out a coating inspection during construction period or regular working hours. However, in the event that it is necessary to inspect at a time other than during regular working hours, including weekends or holidays, in order to meet the building schedule, the shipyard or fabricator shall notify the inspector in advance in sufficient time to allow the inspector to be present and the coating inspector shall cooperate with the shipyard or fabricator by attending such inspection.

## 7.2.4 Inspection results

**7.2.4.1** If the coating inspector requests an additional test, measurement, etc. to that described in the scope of this part of ISO 16145, reasonable evidence for the request shall be made in advance.

**7.2.4.2** The decision of the inspection results shall be made reasonably, in accordance with common knowledge and PSPC requirements.

## 7.2.5 Inspection items

The coating inspector, including the assistant to the coating inspector, shall inspect the items described in Table 6, as a minimum, during the progress of surface preparation and coating work.

Table 6 — Coating inspection items

Step	Inspection item	Remarks
Primary surface preparation	Temperature of steel plate, relative humidity, dew point	Periodic check (usually once per month)
	Degree of water soluble salt	
	Oil, grease and other contaminants	
	Dry film thickness of shop primer	
Block fabrication and block coating	Condition of steel plate (e.g. treatment of edge etc.)	Visual check prior to the start of secondary surface preparation after fabrication of block
	Temperature of steel plate, relative humidity, dew point	Observation record during or after coating
	Oil, grease and other contaminants	Visual check prior to the start of secondary surface preparation after fabrication of block
	Degree of water soluble salt, dust, surface roughness	Measurement of the degree of salt content is carried out once per block. Visual inspection shall be carried out to check dust level at steel surfaces. Tape test of dust level according to ISO 8502-3 may be dispensed if agreed by the parties
	Stripe coating	
	Dry film thickness	Details are given in 7.3
Pre-erection and erection and mooring in the quay	Temperature of steel plate, relative humidity, dew point	Inspection of pre-erection and erection joints is limited to visual inspection, depending upon the judgment of coating inspector
	Oil, grease and other contaminants	
	Degree of water soluble salt, dust, surface roughness	
	Stripe coating	
	Dry film thickness	Details are given in 7.3
<p>Block final inspection after coating is normally carried out before pre-erection or erection. However, it is possible to carry it out after pre-erection or erection under the condition that the proper preparation for inspection is made.</p> <p>Inspection for the primary surface preparation step can be done in accordance with the above inspection cycle, if the conditions described in 6.3.1.4 are satisfied and the procedure for coating process is documented. However, the inspection cycle in other cases is agreed among the ship owners, shipyards and coating manufacturers.</p>		

### 7.3 Dry film thickness measurement

#### 7.3.1 General

**7.3.1.1** Dry film thickness shall be measured by using a magnetic type or an electromagnetic type measuring instrument.

NOTE For calibration of the gauge, see Reference [11] in the Bibliography.

**7.3.1.2** Total dry film thickness shall be measured after final coating. Representative dry film thickness is normally measured, except for final coating, for the guideline of subsequent coating work.

**7.3.1.3** The dry film thickness shall not be measured in order to eliminate errors of measurement in the part where the stripe coating is applied and/or where measurement of dry film thickness is impracticable such as the edge of a structure or section of a hole.

#### 7.3.2 Measurement of dry film thickness and acceptance criteria

The number of measurements (including measuring point) shall be taken as follows (see Figure 5 for an example).

**7.3.2.1** One gauge reading per 5 m<sup>2</sup> of flat surface areas.

**7.3.2.2** One gauge reading at 2 m to 3 m intervals and as close as possible to tank boundaries, but not further than 15 mm from the edges of tank boundaries.

A tank boundary is the extreme longitudinal, transverse, and vertical corner welds of the tank boundary plates, and gauge readings shall be taken adjacent to the welds, not further than 15 mm from the welds.

**7.3.2.3** One set of gauge readings for longitudinal and transverse stiffener member as shown in Figure 4, taken at 2 m to 3 m run and not less than two sets between the primary support members.

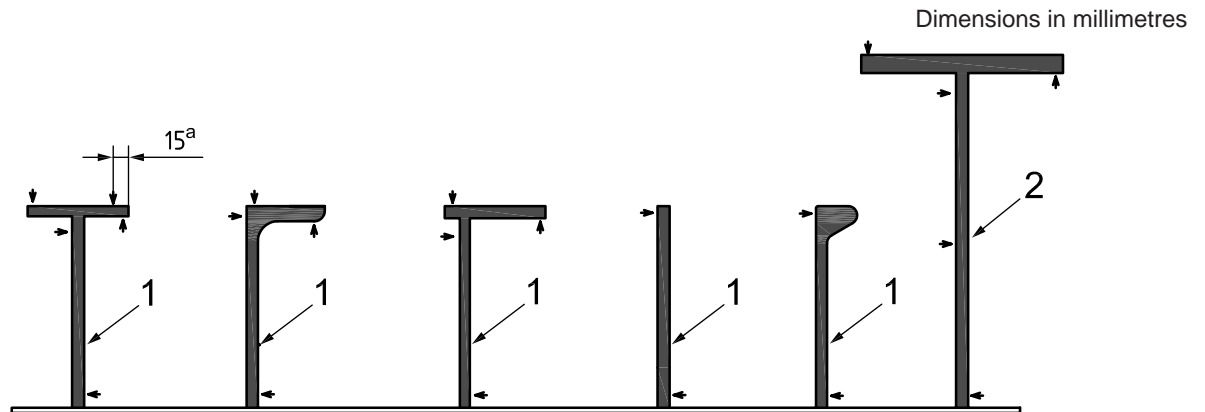

**Key**

1 longitudinals and transverse stiffeners with various shapes

2 primary support member

<sup>a</sup> From the edge.

NOTE The arrow mark (→) indicates a typical measuring point, and implies both sides including the side that is not indicated.

**Figure 4 — Typical measurement point of dry film thickness for each member shape**

**7.3.2.4** Three gauge readings for each set of primary support members and one or two gauge readings for each set of other members as indicated by the arrows in Figure 4. However, one gauge reading to be taken for the bulb and flat bar longitudinals.

**7.3.2.5** For primary support members (girders and transverses), one set of gauge readings for 2 m to 3 m run as shown in Figure 4, but not less than three sets between the primary support members.

**7.3.2.6** Longitudinal girder and transverse web in double skin structure shall be measured as flat surface areas, i.e. one gauge reading per 5 m<sup>2</sup> and at least one reading per girder or transverse web.

**7.3.2.7** The opening (hole) larger than a diameter of 400 mm (bigger than 0,125 m<sup>2</sup> when converted as area) is measured in each point of the front and rear side of the opening.

**7.3.2.8** Five gauge readings per square metre (m<sup>2</sup>), but not less than three gauge readings taken at complex areas (i.e. large brackets of primary support members).

**7.3.2.9** The coating inspector may measure the localized part additionally for the part thought to be necessary in order to verify the dry film thickness. However, reasonable evidence for the additional measurement shall be suggested in advance.

**7.3.3 Acceptance criteria for dry film thickness**

7.3.3.1 90/10 rule is applied.

7.3.3.2 Any unusually high or low measurement values, which are not repetitive, shall be neglected.

Dimensions in millimetres

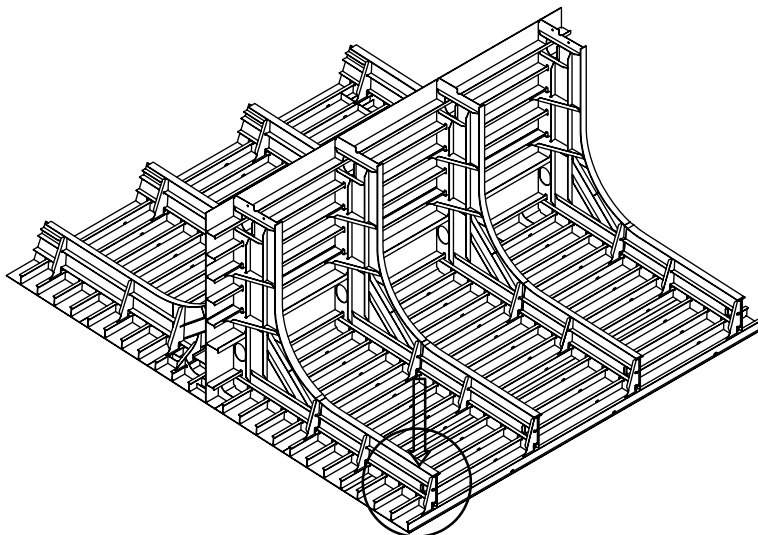

**a) Three-dimensional view of sample block**



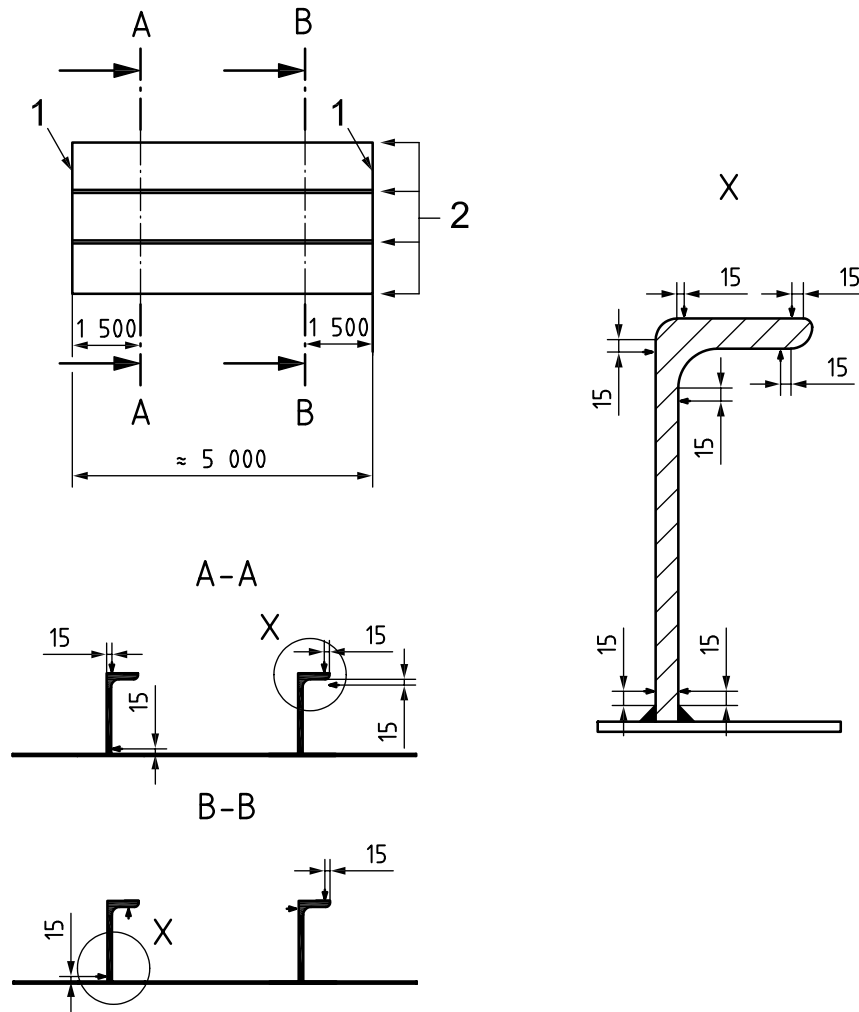

b) Typical plan for one bay

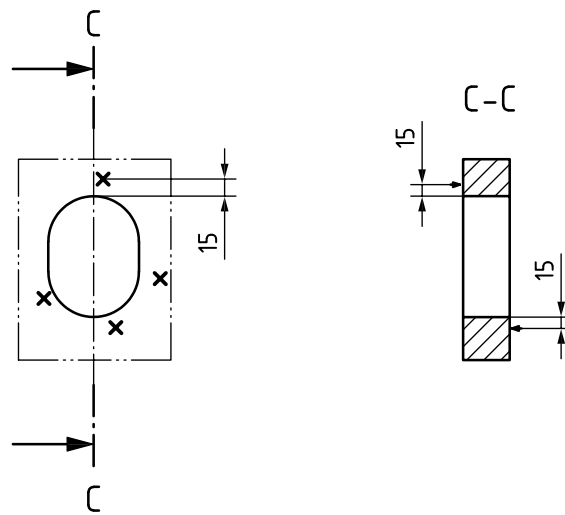

c) Circumference of opening

**Key**

- 1 web frame(s)
- 2 longitudinal(s)

NOTE 1 See Table 7 for number of dry film thickness measurement on each case.

NOTE 2 The arrow mark (→) indicates a typical measuring point, and implies both sides including the side that is not indicated.

**Figure 5 — Measurement example of dry film thickness for deck block of VLCC**

**Table 7 — Measurement example of dry film thickness for sample block**

Category		Standard	Area/ length	Number of measurement	Remarks
Flat plate	Deck plate and bulkhead plate	One point per 5 m <sup>2</sup>	800 m <sup>2</sup>	160	20 points per bay, (17 points: deck plate, Three points: bulkhead plate)
Support member	Primary support members	Three points per 2 m to 3 m	150 m	150	
	Longitudinals, support members	Two points per 2 m to 3 m	150 m	300	Measurement of two sets per frame space
Opening	Circumference of opening	Two points for each opening	Six openings	12	
Boundary of tank		One point per 2 m to 3 m	45 m	15	
Total				637	
Circumference of welding joint		Statistical sampling		30	Measurement for exemption of stripe coating

## Annex A (informative)

### Measurement of the conductivity for abrasives

#### A.1 Measurement of conductivity

The measurement of conductivity shall be made in accordance with ISO 11127-6.

##### A.1.1 Method for measuring conductivity

###### A.1.1.1 Apparatus

The apparatus for measuring conductivity shall be as follows.

**A.1.1.1.1 Beaker**, with 250 ml capacity.

**A.1.1.1.2 Distilled water**, conductivity shall be lower than 0,1 mS/m.

**A.1.1.1.3 Conductivity meter**.

**A.1.1.1.4 Thermometer**.

**A.1.1.1.5 Stopwatch**.

**A.1.1.1.6 Balance**.

###### A.1.1.2 Test procedures

The test shall be carried out in the following sequence and conditions:

- a) rinse beakers and stirring rods with distilled water;
- b) add 100 ml of distilled water to 100 g of abrasive into the beaker;
- c) shake for 5 min;
- d) let stand for 1 h and then shake again for 5 min;
- e) filter sufficient supernatant liquid for tests;
- f) check the conductivity of solution with the conductivity meter.

## A.2 Calculation of conductivity

The specific conductivity of the abrasive shall be calculated using the following formula:

$$C_s = C_m \times K$$

where

$C_s$  is electric conductivity of abrasive (mS/m);

$C_m$  is electric conductivity of solution at 20 °C(mS/m);

$K$  is cell constant.

## Annex B (informative)

### Measurement of water soluble salt

#### B.1 Measurement of the water soluble salt

The water soluble salt on the surface to be coated after primary and secondary surface preparation shall be no more than 50 mg/m<sup>2</sup>, and the measurement shall be based on ISO 8502-9:1998 as described in this annex. However, an instrument other than Bresle patch can be used to determine salt levels provided that the instrument has passed independent testing in accordance with NACE SP0508-2010.

##### B.1.1 Preparation of test solution and blank test

A blank test shall be done as follows in order to prevent foreign substances from affecting the measurement results of the degree of water soluble salt:

- a) fill the beaker with the solution of 10 ml ~ 20 ml (distilled water);
- b) fill the syringe with the solution contained in the beaker and empty the solution in the syringe into the beaker completely;
- c) measure the conductivity of the solution in the beaker.

##### B.1.2 Extraction of water soluble salt from the surface and measurement of conductivity

Carry out Clause 5 of ISO 8502-6:1995 in the following sequence and conditions:

- a) fill ¼ of the solution contained in the beaker into the syringe;
- b) attach the type A-1250 patch and inject the solution;
- c) suction the solution (in the patch) with the syringe after 1 min;
- d) repeat re-injection and suction ten times;
- e) measure the conductivity after collecting the solution (from the patch).

##### B.1.3 Blank test for patch

The patch shall not cause any noticeable contamination of the extraction liquid. Certain patches are available today which are guaranteed to cause an ionic contamination of less than 7 mg/m<sup>2</sup>, which is generally satisfactory. If there is no guarantee or improved accuracy is required, then the blank test shall be carried out.

#### B.2 Calculation of water soluble salt

The water soluble salt shall be calculated in accordance with ISO 8502-9:1998, Clause 7 and it can be calculated by using the conversion factor in Table B.1. If the blank test for a patch is applied, the final salt content shall be calculated by subtracting the compensated value from the measured value.

Table B.1 — Conversion factor for the water soluble salt

Type of patch	Volume of measured solution	Conversion factor	Remarks
A-1250	10 ml	4	
	15 ml	6	
	20 ml	8	
<p>NOTE 1 If the value of the difference between the conductivities (<math>\mu\text{S}/\text{cm}</math>) measured in B.1.1 and B.1.2 is multiplied by a conversion factor, the value of water soluble salt (<math>\text{mg}/\text{m}^2</math>) is obtained.</p> <p>NOTE 2 If the blank test for a patch is applied, the final degree of water soluble salt shall be calculated by subtracting the compensated value from the measured value.</p>			

## Annex C (informative)

### Inspection items and management of inspection

#### C.1 Qualification of coating inspector

##### C.1.1 Inspection items and qualifications of a coating inspector

Inspection items and qualifications of the coating inspector shall be as shown in Table C.1.

**Table C.1 — Inspection items and qualifications of a coating inspector**

Inspection item	Qualification requirement	Remarks
Inspection for all PSPC related matters	Inspection shall be carried out by the coating inspector(s) certified as minimum to NACE Coating Inspector Level 2, FROSIO Inspector Level III or equivalent as specified in IACS UI SC 223, 6.1 interpretations and verified by the administration (or classification society)	The coating inspector shall be agreed by the ship owner, ship yard and coating manufacturer

##### C.1.2 Inspection items and qualifications of an assistant to coating inspector

Inspection items and qualifications of an assistant to coating inspector shall be as shown in Table C.2.

**Table C.2 — Inspection items and qualifications of an assistant to coating inspector**

Inspection item	Qualification requirements	Remarks
Inspection for steel condition (welds, edge preparation, etc.)	Experience for the corresponding items and the coating inspector's satisfaction	Record of nomination and education by the coating inspector shall be maintained
Part of PSPC related inspection under direct supervision of coating inspector	NACE Coating Inspector Level 1 with a minimum of two years' relevant experience, FROSIO Inspector Level II or equivalent	

#### C.2 Inspection items and management of inspection for each process

##### C.2.1 Inspection items in the primary surface preparation step and inspection management

Inspection items in the primary surface preparation step and inspection management shall be as shown in Table C.3.

**Table C.3 — Inspection items in the primary surface preparation step and inspection management**

Item	Inspection management	Inspection time	Inspection method	Inspection standard
Weather conditions	Coating inspector or assistant to coating inspector	—	—	—
Temperature of steel plate		—	—	Recommendation of the coating manufacturer
Surface preparation		Once per month	Select one steel plate	ISO 8501-1:2007
Surface roughness				ISO 8503-1:2012, ISO 8503-2:2012
Water soluble salt				ISO 8502-9:1998
Other contamination				Recommendation of the coating manufacturer
Coating material				Arbitrary selection
Dry film thickness		Select one steel plate	Recommendation of the coating manufacturer	

**C.2.2 Inspection items in the assembly step and inspection management**

Inspection items in the assembly step and inspection management shall be as shown in Table C.4.

**Table C.4 — Inspection items in the assembly step and inspection management**

Item	Inspection management	Inspection time	Inspection method	Inspection standard
Welds	Assistant to coating inspector	Assembly step	All blocks	ISO 8501-3:2001
Edges				
Surface (general)				

**C.2.3 Inspection items in the secondary surface preparation step and inspection management for blocks**

Inspection items in the secondary surface preparation step and inspection management for blocks shall be as shown in Table C.5.

**Table C.5 — Inspection items in the secondary surface preparation step and inspection management for blocks**

Item	Inspection management	Inspection time	Inspection method	Inspection standard
Surface preparation	Coating inspector or assistant to coating inspector	Before first coating	All blocks	ISO 8501-1:2007, JSTRA/SPSS
Surface roughness				ISO 8503-1:2012, ISO 8503-2:2012
Water soluble salt				ISO 8502-9:1998
Dust				Visual inspection or ISO 8502-3:1992
Other contamination				Recommendation of the coating manufacturer

**C.2.4 Inspection items in the block coating step and inspection management**

Inspection items in the block coating step and inspection management shall be as shown in Table C.6.



**Table C.6 — Inspection items in the block coating step and inspection management**

Item	Inspection management	Inspection time	Inspection method	Inspection standard
Weather condition	Coating inspector or assistant to coating inspector	During coating	All blocks	—
Temperature of steel plate		Before coating		Recommendation of the coating manufacturer
Other contamination		After coating		Visual inspection
Stripe coating	Assistant to coating inspector	During coating		—
Wet film thickness	Coating worker	After coating		—
Dry film thickness	Line QC			

### C.2.5 Inspection items in the block final step and inspection management

Inspection items in the block final step and inspection management shall be as shown in Table C.7.

**Table C.7 — Inspection items in the block final step and inspection management**

Item	Inspection management	Inspection time	Inspection method	Inspection standard
Dry film thickness	Assistant to coating inspector	After coating	All blocks	See 7.3.2
Dry film thickness in the vicinity of welding line (for exemption of stripe coating)				Statistical sampling (30 spots per block)
Nominal dry film thickness (NDFT)	Coating inspector	After measuring dry film thickness	Decision of the result	90/10 rule
Coating defect	Coating inspector or assistant to coating inspector	After coating	All blocks	Visual inspection

### C.2.6 Inspection items in the erection step and inspection management

Inspection items in the erection step (after pre-erection and erection) and inspection management shall be as shown in Table C.8.

**Table C.8 — Inspection items in the erection step and inspection management**

Item	Inspection management	Inspection time	Inspection method	Inspection standard
Spatter	Assistant to coating inspector	Erection step	Unit of tank	ISO 8501-3:2001
Welding joint				

### C.2.7 Inspection items in the step just before secondary surface preparation and inspection management for erection joints

Inspection items in the step just before secondary surface preparation and inspection management for erection joints shall be as shown in Table C.9.

**Table C.9 — Inspection items in the step just before secondary surface preparation and inspection management for erection joints**

Item	Inspection management	Inspection time	Inspection method	Inspection standard
Damage of coating down to the steel substrate	Coating inspector or assistant to coating inspector	After forming tank	Unit of tank	—
Damaged area				See Annex D

**C.2.8 Inspection items in the secondary surface preparation step and inspection management for erection joints**

Inspection items in the secondary surface preparation step and inspection management for erection joints shall be as shown in Table C.10.

**Table C.10 — Inspection items in the secondary surface preparation step and inspection management for erection joints**

Item	Inspection management	Inspection time	Inspection method	Inspection standard
Surface preparation	Coating inspector or assistant to coating inspector	Before first coating	Near erection welding line	ISO 8501-1:2007, JSTRA/SPSS
Water soluble salt				ISO 8502-9:1998
Dust				Visual inspection or ISO 8502-3:1992
Other contamination				Recommendation of the coating manufacturer

**C.2.9 Inspection items in the coating step and inspection management for erection joints**

Inspection items in the coating step and inspection management for erection joints shall be as shown in Table C.11.

**Table C.11 — Inspection items in the coating step and inspection management for erection joints**

Item	Inspection management	Inspection time	Inspection method	Inspection standard
Weather condition	Coating inspector or assistant to coating inspector	During coating	Near erection welding line	—
Temperature of steel plate		Before coating		Recommendation of the coating manufacturer
Other contamination				
Stripe coating	Assistant to coating inspector	After coating		Visual inspection
Wet film thickness	Coating worker	During coating		—
Dry film thickness	Line QC	After coating	—	

**C.2.10 Inspection items in the tank final step and inspection management**

Inspection items in the tank final step and inspection management shall be as shown in Table C.12.

Table C.12 — Inspection items in the tank final and inspection management

Item	Inspection management	Inspection time	Inspection method	Inspection standard
Dry film thickness	Assistant to coating inspector	After coating	Near erection welding line	See 7.3.2
Dry film thickness near welding line (for exemption of stripe coating)				Statistical sampling (30 spots per block)
Nominal dry film thickness (NDFT)	Coating inspector	After measuring dry film thickness	Decision of the result	90/10 rule
Defect of welding	Coating inspector or assistant to coating inspector	After coating	Near erection welding line	Visual inspection

## Annex D (informative)

### Assessment of the degree of damage

Figure D.1 shall be used for assessment of the degree of damage in the tank for selecting a method of surface preparation after pre-erection or erection.

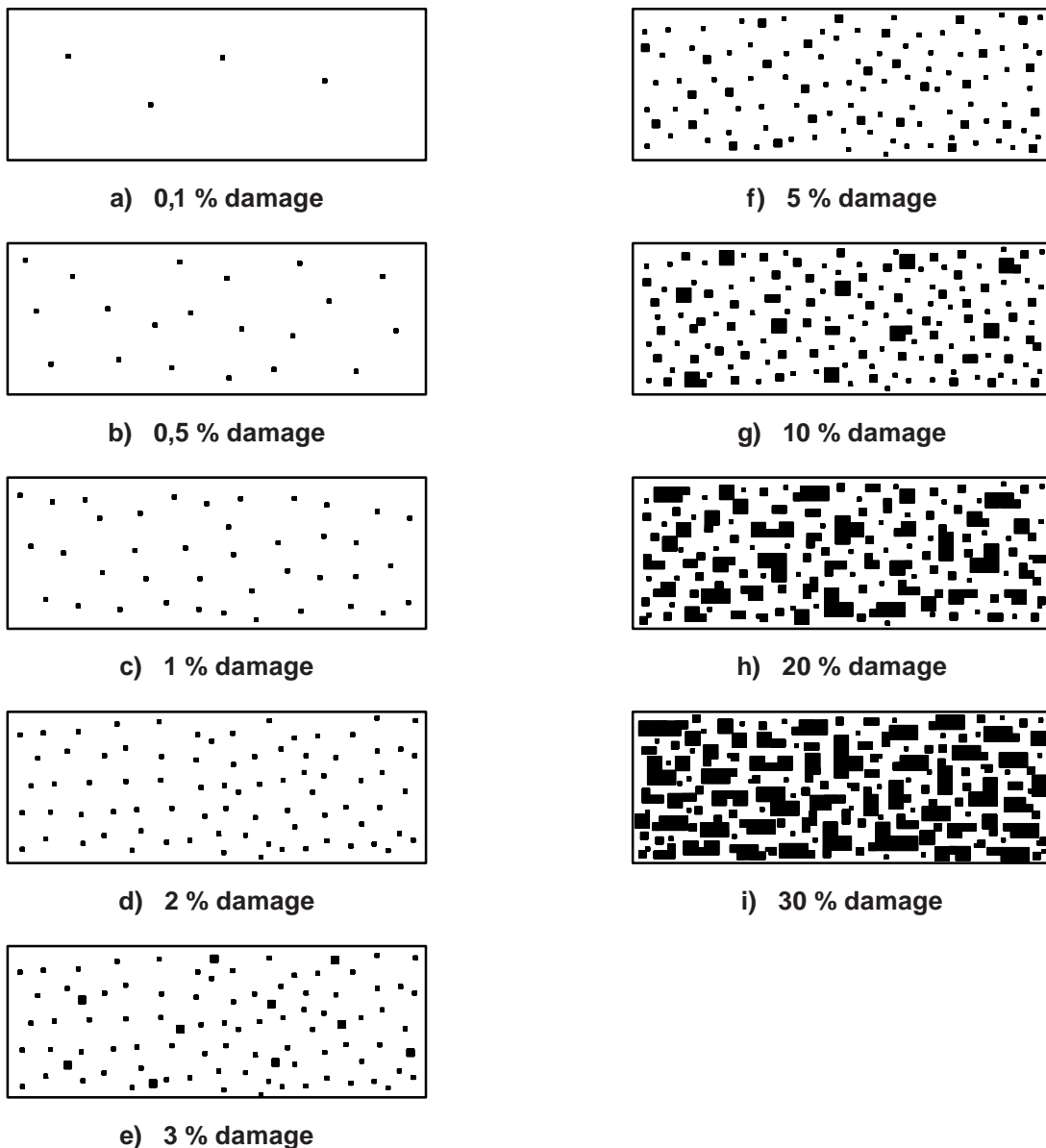

Figure D.1 — Reference figure for the degree of damage

## Annex E (informative)

### Standard for coating technical file (CTF)

#### E.1 Standard for CTF

##### E.1.1 Contents to be included in the CTF

###### E.1.1.1 Copy of the type approval certificate

The coating material shall be type approved in accordance with the PSPC/COT [Resolution MSC.288(87)] and the certificate shall include information on the crossover test with a shop primer when relevant.

###### E.1.1.2 Copy of the instruction manual (technical data sheet)

The instruction manual for coating material issued by the coating manufacturer shall include at least the following information:

- a) product name and identification mark and/or number;
- b) materials, components and composition of the coating system, colours;
- c) minimum and maximum dry film thickness; the minimum and maximum allowable dry film thickness may not be included in the instruction manual and replaced by a separate document;
- d) application methods, tools and/or machines;
- e) condition of surface to be coated (de-rusting grade, cleanliness, profile, etc.);
- f) environmental limitations (temperature and humidity).

###### E.1.1.3 Record of coating work

A record of coating application including the following shall be included in the coating technical file:

- a) applied actual space and area (m<sup>2</sup>) of each compartment;
- b) applied coating system;
- c) coating time, dry film thickness, and the number of coating layers;
- d) weather condition during coating;
- e) method of surface preparation.

###### E.1.1.4 Procedure for inspection and repair of coating system in new building

A procedure for inspection including assignment of coating inspector and repair of coating system in new building shall be included in the CTF.

###### E.1.1.5 Coating log

The coating inspector shall note in the coating log that the coating was applied satisfactorily according to the coating manufacturer's procedures. Matters other than the procedure shall also be recorded. Refer to the example form in E.1.2.

**E.1.1.6 Verification of inspection**

A record for verification of inspection shall include the following:

- a) completion date of inspection;
- b) inspection result;
- c) (coating inspector's) comment (limited to the case of existence);
- d) signature of inspector.

NOTE Verification of inspection is not a separate document but includes matters normally included in the reports mentioned through E.1.2 and E.1.6.

**E.1.1.7 In-service maintenance and repair for the coating system**

The process of in-service maintenance and repair for the coating system during operation (after delivery of ship) shall follow MSC.1/Circ. 1399, the guidelines on procedures for in-service maintenance and repair of coating systems for cargo oil tanks of crude oil tankers.

© ISO 2012 – All rights reserved

## E.1.2 Example inspection report form

## Inspection report for primary surface preparation

Sheet No.: PSP-\_\_\_\_\_.

Project number or ship name	
Plate numbers	
Inspection date	

## Environmental condition

Dry bulb temperature (°C)		Remarks:
Relative humidity (%)		
Dew point (°C)		
Surface temperature (°C)		

## Surface preparation

Surface roughness (between 30 µm and 75 µm)	<input type="checkbox"/> Pass <input type="checkbox"/> Fail	<input type="checkbox"/> Fine <input type="checkbox"/> Medium <input type="checkbox"/> Coarse	Remarks:
Water soluble salts (≤ 50 mg/m <sup>2</sup> )	<input type="checkbox"/> Pass <input type="checkbox"/> Fail	mg/m <sup>2</sup>	

## Shop primer

Manufacturer		Remarks:
Product name		
Identification mark/Number		
Specified DFT		
Measured DFT		

Checked by <input type="checkbox"/> Coating inspector <input type="checkbox"/> Assistant to coating inspector <input type="checkbox"/> Line QC	Name:	Verified by Coating inspector	Name:
	Signature:		Signature:

## Inspection report for secondary surface preparation

Sheet No.: SSP-\_\_\_\_\_.

Project number or ship name	
Part of structure (Block name/Tank No., etc.)	
Name of shipyard	
Construction stage	<input type="checkbox"/> Block assembly / <input type="checkbox"/> Pre-erection / <input type="checkbox"/> Erection

### Steel condition

Inspection date (time)		Remarks:
Welds	<input type="checkbox"/> Pass <input type="checkbox"/> Fail	
Edges	<input type="checkbox"/> Pass <input type="checkbox"/> Fail	
Surface (general)	<input type="checkbox"/> Pass <input type="checkbox"/> Fail	

### Secondary surface preparation

Inspection date (time)		Remarks:	
Surface roughness (between 30 µm and 75 µm)	<input type="checkbox"/> Pass <input type="checkbox"/> Fail		<input type="checkbox"/> Fine <input type="checkbox"/> Medium <input type="checkbox"/> Coarse
Water soluble salts (≤ 50 mg/m <sup>2</sup> )	<input type="checkbox"/> Pass <input type="checkbox"/> Fail		mg/m <sup>2</sup>
Dust	<input type="checkbox"/> Pass <input type="checkbox"/> Fail		
Oil contamination	<input type="checkbox"/> Pass <input type="checkbox"/> Fail		
Result of inspection	<input type="checkbox"/> Pass <input type="checkbox"/> Fail		

Checked by <input type="checkbox"/> Coating inspector <input type="checkbox"/> Assistant to coating inspector <input type="checkbox"/> Line QC	Name:  Signature:	Verified by Coating inspector	Name:  Signature:
---	-------------------------	----------------------------------	-------------------------



## Coating log

Sheet No.: CL-\_\_\_\_\_.

Project number or ship name	
Part of structure (Block name/Tank No., etc.)	
Name of shipyard	
Construction stage	<input type="checkbox"/> Block assembly / <input type="checkbox"/> Pre-erection / <input type="checkbox"/> Erection

### Intermediate coating

Sequence	Paint name (Batch No.)	Date (Time)	Environmental condition			
			Dry bulb temperature	Relative humidity	Dew point	Surface temperature
First coat			°C	%	°C	°C
Second coat			°C	%	°C	°C

### Dry film thickness measurement

Specified DFT	320 µm	Max. DFT	µm
		Min. DFT	µm
Measured DFT	Number of points		
	Average DFT	µm	
	Max./Min. DFT	µm / µm	
	90/10 rule	<input type="checkbox"/> Pass <input type="checkbox"/> Fail	
Result of inspection	<input type="checkbox"/> Pass <input type="checkbox"/> Fail		
Remarks:			

### Dry film thickness measurement on welds

Measured DFT	Average/Max./Min. DFT	µm /	µm /	µm
Result of inspection	<input type="checkbox"/> Pass <input type="checkbox"/> Fail			

Checked by <input type="checkbox"/> Coating inspector <input type="checkbox"/> Assistant to coating inspector <input type="checkbox"/> Line QC	Name:  Signature:	Verified by  Coating inspector	Name:  Signature:
---	-------------------------	--------------------------------------	-------------------------

E.1.3 Example block list form

**Block list**

Block name	Coated area of COT m <sup>2</sup>	Fabrication and painting site	Remarks





**E.1.6 Example summary form for tank inspection**

**Summary for tank inspection**

No.	Compartment or tank name	Date of inspection	Result of inspection	Remarks

© ISO 2012. All rights reserved. No reproduction or networking permitted without license from IHS.

## Bibliography

- [1] ISO 8501-1:1988<sup>2)</sup>, *Preparation of steel substrates before application of paints and related products — Visual assessment of surface cleanliness — Part 1: Rust grades and preparation grades of uncoated steel substrates and of steel substrates after overall removal of previous coatings*
- [2] ISO 8501-1:1988/Suppl:1994<sup>3)</sup>, *Preparation of steel substrates before application of paints and related products — Visual assessment of surface cleanliness — Part 1: Rust grades and preparation grades of uncoated steel substrates and of steel substrates after overall removal of previous coatings — Supplement: Representative photographic examples of the change of appearance imparted to steel when blast-cleaned with different abrasives*
- [3] ISO 8502-6:1995<sup>4)</sup>, *Preparation of steel substrates before application of paints and related products — Tests for the assessment of surface cleanliness — Part 6: Extraction of soluble contaminants for analysis — The Bresle method*
- [4] ISO 11127-6, *Preparation of steel substrates before application of paints and related products — Test methods for non-metallic blast-cleaning abrasives — Part 6: Determination of water-soluble contaminants by conductivity measurement*
- [5] ISO 16145-1, *Ships and marine technology — Protective coatings and inspection methods — Part 1: Dedicated sea water ballast tanks*
- [6] IMO MSC.1/Circ. 1399, *Guidelines on procedures for in-service maintenance and repair of coating systems for cargo oil tanks of crude oil tankers*
- [7] JSTRA, SPSS for PSPC, *Standard for the preparation of steel substrates for PSPC*
- [8] NACE SP0508-2010, *Standard practice: Methods of validating equivalence to ISO 8502-9:1998 on measurement of the levels of soluble salts*
- [9] The Industry JWG/Coatings, *Guideline for implementation of Performance standard for protective coatings for dedicated ballast tanks in all types of ships and double-side skin spaces of bulk carriers [resolution MSC.215 (82)]*
- [10] JSRA-SPSS:1984, *Standard for the preparation of steel surface prior to painting*
- [11] SSPC PA2:2004, *Paint application specification No.2 — Measurement of dry coating thickness with magnetic gages*
- [12] Supplement to the International Oil Pollution Prevention Certificate (Form B), *Record of construction and equipment for oil tankers*

- 
- 2) Withdrawn International Standard.
  - 3) Withdrawn International Standard.
  - 4) Withdrawn International Standard revised by ISO 8502-6:2006.

.....

---

---

**ICS 47.020.99**

Price based on 40 pages

-----