Aerospace fluid systems — O-rings, inch series: Inside diameters and cross sections, tolerances and size-identification codes —

**Part 2:
Standard tolerances for non-hydraulic systems**

Systèmes aérospaciaux de fluides — Joints toriques, série en inches: diamètres intérieurs et sections, tolérances et codes d'identification dimensionnelle —

Partie 2: Tolérances standards pour systèmes non hydrauliques



PDF disclaimer

This PDF file may contain embedded typefaces. In accordance with Adobe's licensing policy, this file may be printed or viewed but shall not be edited unless the typefaces which are embedded are licensed to and installed on the computer performing the editing. In downloading this file, parties accept therein the responsibility of not infringing Adobe's licensing policy. The ISO Central Secretariat accepts no liability in this area.

Adobe is a trademark of Adobe Systems Incorporated.

Details of the software products used to create this PDF file can be found in the General Info relative to the file; the PDF-creation parameters were optimized for printing. Every care has been taken to ensure that the file is suitable for use by ISO member bodies. In the unlikely event that a problem relating to it is found, please inform the Central Secretariat at the address given below.

© ISO 2003

All rights reserved. Unless otherwise specified, no part of this publication may be reproduced or utilized in any form or by any means, electronic or mechanical, including photocopying and microfilm, without permission in writing from either ISO at the address below or ISO's member body in the country of the requester.

ISO copyright office
Case postale 56 • CH-1211 Geneva 20
Tel. + 41 22 749 01 11
Fax + 41 22 749 09 47
E-mail copyright@iso.org
Web www.iso.org

Published in Switzerland

Foreword

ISO (the International Organization for Standardization) is a worldwide federation of national standards bodies (ISO member bodies). The work of preparing International Standards is normally carried out through ISO technical committees. Each member body interested in a subject for which a technical committee has been established has the right to be represented on that committee. International organizations, governmental and non-governmental, in liaison with ISO, also take part in the work. ISO collaborates closely with the International Electrotechnical Commission (IEC) on all matters of electrotechnical standardization.

International Standards are drafted in accordance with the rules given in the ISO/IEC Directives, Part 2.

The main task of technical committees is to prepare International Standards. Draft International Standards adopted by the technical committees are circulated to the member bodies for voting. Publication as an International Standard requires approval by at least 75 % of the member bodies casting a vote.

Attention is drawn to the possibility that some of the elements of this document may be the subject of patent rights. ISO shall not be held responsible for identifying any or all such patent rights.

ISO 16031-2 was prepared by Technical Committee ISO/TC 20, *Aircraft and space vehicles*, Subcommittee SC 10, *Aerospace fluid systems and components*.

ISO 16031 consists of the following parts, under the general title *Aerospace fluid systems — O-rings, inch series: Inside diameters and cross sections, tolerances and size-identification codes*:

- *Part 1: Close tolerances for hydraulic systems*
- *Part 2: Standard tolerances for non-hydraulic systems*

Introduction

In fluid power systems, power is transmitted through a fluid (liquid or gas) under pressure within an enclosed circuit. Components are designed to meet these requirements under varying conditions. Testing of components to meet performance requirements provides users with a basis of assurance for determining design applications and for checking component compliance with their stated requirements.

Aerospace fluid systems — O-rings, inch series: Inside diameters and cross sections, tolerances and size-identification codes —

Part 2: Standard tolerances for non-hydraulic systems

1 Scope

This part of ISO 16031 specifies the inside diameters, cross-sections, tolerances and size identification codes for inch O-rings used in aerospace fluid systems intended for use in non-hydraulic systems.

This part of ISO 16031 is applicable, provided that suitable tooling is available, to O-rings made from all other elastomeric materials other than nitrile and ethylene propylene materials, for which ISO 16031-1 specifies the dimensions.

Specifications for O-rings with an inside diameter $d_1 \leq 12,7$ mm have been taken from ISO 16031-1, because the same tolerances are applicable to the O-rings in this part of ISO 16031.

2 Normative references

The following referenced documents are indispensable for the application of this document. For dated references, only the edition cited applies. For undated references, the latest edition of the referenced document (including any amendments) applies.

ISO 5598:1985, *Fluid power systems and components — Vocabulary*

3 Terms and definitions

For the purposes of this document, the terms and definitions given in ISO 5598 apply.

NOTE Throughout this part of ISO 16031, the term “O-ring” has been adopted although the correct technical term is “toroidal sealing ring”.

4 Configuration

The shape of the O-ring shall be toroidal as shown in Figure 1.

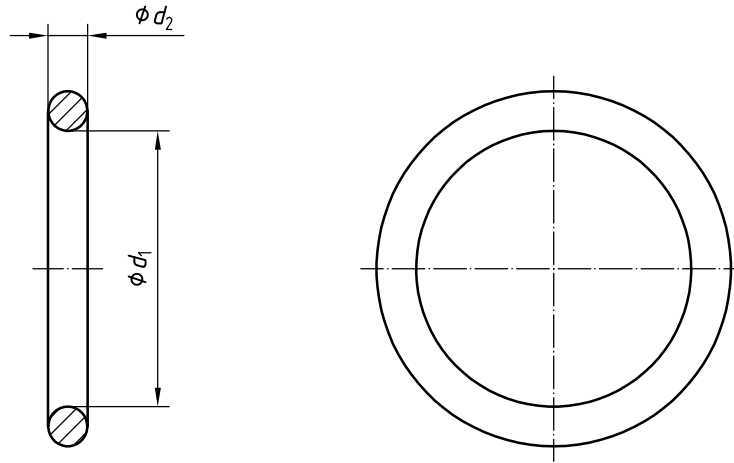

Key

- d_1 inside diameter
- d_2 cross-section diameter

Figure 1 — Typical O-ring configuration

5 Inside diameters, cross-sections and tolerances

The combinations of inside diameters, d_1 , cross-sections, d_2 , and O-ring tolerances shall be chosen from Tables 1 and 2.

6 Size identification code

6.1 Table 1 lists the dimensions of O-rings and their corresponding size identification code from -001 to -475. The size identification codes are divided into groups of one hundred and within each group are sequential and not significant. Each group of one hundred identifies the cross-section size of the O-rings within the group.

EXAMPLE

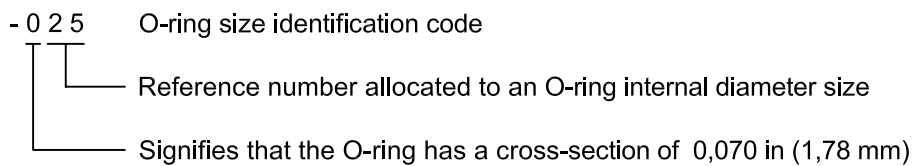

Reference to Table 1 establishes that -025 represents an O-ring with a cross-section of 0,070 in (1,78 mm) and an internal diameter of 1,165 in to 1,187 in (29,59 mm to 30,15 mm).

6.2 Table 2 lists the dimensions of O-rings and their corresponding size identification code for the 900 series, which includes all of the currently standardized O-rings for sealing straight thread tube-fitting bosses. This series utilizes a significant dash numbering system, where the dash number designates the tube size in 1/16ths in, with the exception of the -901, which is intended for a 0,093 8 in (2,38 mm) nominal outside diameter tube.

EXAMPLE

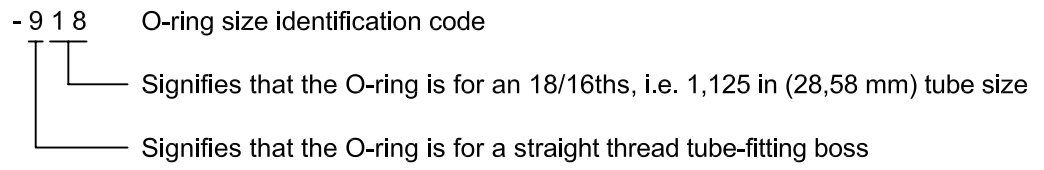

Table 1 — Inside diameters, cross-sections and tolerances

Size identi- fication code	Internal diameter				Cross-section				Volume (Ref.)	
	d_1		d_2		in		mm		in ³	cm ³
	min.	max.	min.	max.	min.	max.	min.	max.		
-001	0,025	0,033	0,64	0,84	0,037	0,043	0,94	1,09	0,000 3	0,005
-002	0,038	0,046	0,97	1,17	0,047	0,053	1,19	1,35	0,000 6	0,010
-003	0,052	0,060	1,32	1,52	0,057	0,063	1,45	1,60	0,001 0	0,016
-004	0,065	0,075	1,65	1,90	0,067	0,073	1,70	1,85	0,001 7	0,028
-005	0,096	0,106	2,44	2,69	0,067	0,073	1,70	1,85	0,002 1	0,034
-006	0,109	0,119	2,77	3,02	0,067	0,073	1,70	1,85	0,002 2	0,036
-007	0,140	0,150	3,56	3,81	0,067	0,073	1,70	1,85	0,002 6	0,043
-008	0,171	0,181	4,34	4,60	0,067	0,073	1,70	1,85	0,003 0	0,049
-009	0,203	0,213	5,16	5,41	0,067	0,073	1,70	1,85	0,003 4	0,056
-010	0,234	0,244	5,94	6,20	0,067	0,073	1,70	1,85	0,003 7	0,061
-011	0,296	0,306	7,52	7,77	0,067	0,073	1,70	1,85	0,004 5	0,074
-012	0,359	0,369	9,12	9,37	0,067	0,073	1,70	1,85	0,005 2	0,085
-013	0,421	0,431	10,69	10,95	0,067	0,073	1,70	1,85	0,006 0	0,098
-014	0,484	0,494	12,29	12,55	0,067	0,073	1,70	1,85	0,006 8	0,111
-015	0,544	0,558	13,82	14,17	0,067	0,073	1,70	1,85	0,007 5	0,123
-016	0,605	0,623	15,37	15,82	0,067	0,073	1,70	1,85	0,008 3	0,136
-017	0,667	0,685	16,94	17,40	0,067	0,073	1,70	1,85	0,009 0	0,147
-018	0,730	0,748	18,54	19,00	0,067	0,073	1,70	1,85	0,009 8	0,161
-019	0,792	0,810	20,12	20,57	0,067	0,073	1,70	1,85	0,010 5	0,172
-020	0,855	0,873	21,72	22,17	0,067	0,073	1,70	1,85	0,011 3	0,185
-021	0,917	0,935	23,29	23,75	0,067	0,073	1,70	1,85	0,012 0	0,197
-022	0,979	0,999	24,87	25,37	0,067	0,073	1,70	1,85	0,012 8	0,210
-023	1,041	1,061	26,44	26,95	0,067	0,073	1,70	1,85	0,013 6	0,223
-024	1,104	1,124	28,04	28,55	0,067	0,073	1,70	1,85	0,014 3	0,234
-025	1,165	1,187	29,59	30,15	0,067	0,073	1,70	1,85	0,015 1	0,247
-026	1,228	1,250	31,19	31,75	0,067	0,073	1,70	1,85	0,015 8	0,259
-027	1,290	1,312	32,77	33,32	0,067	0,073	1,70	1,85	0,016 6	0,272
-028	1,351	1,377	34,32	34,98	0,067	0,073	1,70	1,85	0,017 3	0,283
-029	1,476	1,502	37,49	38,15	0,067	0,073	1,70	1,85	0,018 8	0,308
-030	1,601	1,627	40,67	41,33	0,067	0,073	1,70	1,85	0,020 4	0,334
-031	1,724	1,754	43,79	44,55	0,067	0,073	1,70	1,85	0,021 9	0,359
-032	1,849	1,879	46,96	47,73	0,067	0,073	1,70	1,85	0,023 4	0,383
-033	1,971	2,007	50,06	50,98	0,067	0,073	1,70	1,85	0,024 9	0,408
-034	2,096	2,132	53,24	54,15	0,067	0,073	1,70	1,85	0,026 4	0,433
-035	2,221	2,257	56,41	57,33	0,067	0,073	1,70	1,85	0,027 9	0,457
-036	2,346	2,382	59,59	60,50	0,067	0,073	1,70	1,85	0,029 4	0,482
-037	2,471	2,507	62,76	63,68	0,067	0,073	1,70	1,85	0,030 9	0,506
-038	2,594	2,634	65,89	66,90	0,067	0,073	1,70	1,85	0,032 5	0,533
-029	2,719	2,759	69,06	70,08	0,067	0,073	1,70	1,85	0,034 0	0,557
-040	2,844	2,884	72,24	73,25	0,067	0,073	1,70	1,85	0,035 5	0,582
-041	2,965	3,013	75,31	76,53	0,067	0,073	1,70	1,85	0,037 0	0,606
-042	3,215	3,263	81,66	82,88	0,067	0,073	1,70	1,85	0,040 0	0,655
-043	3,465	3,513	88,01	89,23	0,067	0,073	1,70	1,85	0,043 0	0,705
-044	3,712	3,766	94,28	95,66	0,067	0,073	1,70	1,85	0,046 1	0,755
-045	3,962	4,016	100,63	102,01	0,067	0,073	1,70	1,85	0,049 1	0,805

Table 1 (continued)

Size identi- fication code	Internal diameter				Cross-section				Volume (Ref.)	
	d_1		d_2		in		mm		in ³	cm ³
	min.	max.	min.	max.	min.	max.	min.	max.		
-046	4,209	4,269	106,91	108,43	0,067	0,073	1,70	1,85	0,052 1	0,854
-047	4,459	4,519	113,26	114,78	0,067	0,073	1,70	1,85	0,055 1	0,903
-048	4,709	4,769	119,61	121,13	0,067	0,073	1,70	1,85	0,058 1	0,952
-049	4,952	5,026	125,78	127,66	0,067	0,073	1,70	1,85	0,061 2	1,003
-050	5,202	5,276	132,13	134,01	0,067	0,073	1,70	1,85	0,064 2	1,052
*051 to *101	O-ring sizes not assigned									
-102	0,044	0,054	1,12	1,37	0,100	0,106	2,54	2,69	0,004 0	0,066
-103	0,076	0,086	1,93	2,18	0,100	0,106	2,54	2,69	0,004 8	0,079
-104	0,107	0,117	2,72	2,97	0,100	0,106	2,54	2,69	0,005 6	0,092
-105	0,138	0,148	3,51	3,76	0,100	0,106	2,54	2,69	0,006 4	0,105
-106	0,169	0,179	4,29	4,55	0,100	0,106	2,54	2,69	0,007 3	0,120
-107	0,201	0,211	5,11	5,36	0,100	0,106	2,54	2,69	0,008 1	0,133
-108	0,232	0,242	5,89	6,15	0,100	0,106	2,54	2,69	0,008 9	0,146
-109	0,294	0,304	7,47	7,72	0,100	0,106	2,54	2,69	0,010 5	0,172
-110	0,357	0,367	9,07	9,32	0,100	0,106	2,54	2,69	0,012 2	0,200
-111	0,419	0,429	10,64	10,90	0,100	0,106	2,54	2,69	0,013 8	0,226
-112	0,482	0,492	12,24	12,50	0,100	0,106	2,54	2,69	0,015 4	0,252
-113	0,542	0,556	13,77	14,12	0,100	0,106	2,54	2,69	0,017 1	0,280
-114	0,603	0,621	15,32	15,77	0,100	0,106	2,54	2,69	0,018 7	0,306
-115	0,665	0,683	16,89	17,35	0,100	0,106	2,54	2,69	0,020 3	0,333
-116	0,728	0,746	18,49	18,95	0,100	0,106	2,54	2,69	0,022 0	0,361
-117	0,789	0,809	20,04	20,55	0,100	0,106	2,54	2,69	0,023 6	0,387
-118	0,852	0,872	21,64	22,15	0,100	0,106	2,54	2,69	0,025 3	0,415
-119	0,914	0,934	23,22	23,72	0,100	0,106	2,54	2,69	0,026 9	0,441
-120	0,977	0,997	24,82	25,32	0,100	0,106	2,54	2,69	0,028 5	0,467
-121	1,039	1,059	26,39	26,90	0,100	0,106	2,54	2,69	0,030 2	0,495
-122	1,102	1,122	27,99	28,50	0,100	0,106	2,54	2,69	0,031 8	0,521
-123	1,162	1,186	29,51	30,12	0,100	0,106	2,54	2,69	0,033 4	0,547
-124	1,225	1,249	31,12	31,72	0,100	0,106	2,54	2,69	0,035 1	0,575
-125	1,287	1,311	32,69	33,30	0,100	0,106	2,54	2,69	0,036 7	0,601
-126	1,350	1,374	34,29	34,90	0,100	0,106	2,54	2,69	0,038 3	0,628
-127	1,412	1,436	35,86	36,47	0,100	0,106	2,54	2,69	0,040 0	0,655
-128	1,475	1,499	37,46	38,07	0,100	0,106	2,54	2,69	0,041 6	0,682
-129	1,534	1,564	38,96	39,73	0,100	0,106	2,54	2,69	0,043 2	0,708
-130	1,597	1,627	40,56	41,33	0,100	0,106	2,54	2,69	0,044 9	0,736
-131	1,659	1,689	42,14	42,90	0,100	0,106	2,54	2,69	0,046 5	0,762
-132	1,722	1,752	43,74	44,50	0,100	0,106	2,54	2,69	0,048 2	0,790
-133	1,784	1,814	45,31	46,08	0,100	0,106	2,54	2,69	0,049 8	0,816
-134	1,847	1,877	46,91	47,68	0,100	0,106	2,54	2,69	0,051 4	0,842
-135	1,908	1,942	48,46	49,33	0,100	0,106	2,54	2,69	0,053 1	0,870

Table 1 (continued)

Size identi- fication code	Internal diameter				Cross-section				Volume (Ref.)	
	d_1		d_2		in		mm		in ³	cm ³
	in	mm	in	mm	min.	max.	min.	max.		
-136	1,970	2,004	50,04	50,90	0,100	0,106	2,54	2,69	0,054 7	0,896
-137	2,033	2,067	51,64	52,50	0,100	0,106	2,54	2,69	0,056 4	0,924
-138	2,095	2,129	53,21	54,08	0,100	0,106	2,54	2,69	0,058 0	0,950
-139	2,158	2,192	54,81	55,68	0,100	0,106	2,54	2,69	0,059 6	0,977
-140	2,220	2,254	56,39	57,25	0,100	0,106	2,54	2,69	0,061 3	1,005
-141	2,280	2,320	57,91	58,93	0,100	0,106	2,54	2,69	0,062 9	1,031
-142	2,342	2,382	59,49	60,50	0,100	0,106	2,54	2,69	0,064 5	1,057
-143	2,405	2,445	61,09	62,10	0,100	0,106	2,54	2,69	0,066 2	1,085
-144	2,467	2,507	62,66	63,68	0,100	0,106	2,54	2,69	0,067 8	1,111
-145	2,530	2,570	64,26	65,28	0,100	0,106	2,54	2,69	0,069 4	1,137
-146	2,592	2,632	65,84	66,85	0,100	0,106	2,54	2,69	0,071 1	1,165
-147	2,653	2,697	67,39	68,50	0,100	0,106	2,54	2,69	0,072 7	1,191
-148	2,715	2,759	68,96	70,08	0,100	0,106	2,54	2,69	0,074 3	1,218
-149	2,778	2,822	70,56	71,68	0,100	0,106	2,54	2,69	0,076 0	1,245
-150	2,840	2,884	72,14	73,25	0,100	0,106	2,54	2,69	0,077 6	1,272
-151	2,963	3,011	75,26	76,48	0,100	0,106	2,54	2,69	0,080 9	1,326
-152	3,213	3,261	81,61	82,83	0,100	0,106	2,54	2,69	0,087 4	1,432
-153	3,463	3,511	87,96	89,18	0,100	0,106	2,54	2,69	0,094 0	1,540
-154	3,709	3,765	94,21	95,63	0,100	0,106	2,54	2,69	0,100 5	1,647
-155	3,959	4,015	100,56	101,98	0,100	0,106	2,54	2,69	0,107 1	1,755
-156	4,207	4,267	106,86	108,38	0,100	0,106	2,54	2,69	0,113 6	1,862
-157	4,457	4,517	113,21	114,73	0,100	0,106	2,54	2,69	0,120 2	1,970
-158	4,707	4,767	119,56	121,08	0,100	0,106	2,54	2,69	0,126 7	2,076
-159	4,952	5,022	125,78	127,56	0,100	0,106	2,54	2,69	0,133 2	2,183
-160	5,202	5,272	132,13	133,91	0,100	0,106	2,54	2,69	0,139 8	2,291
-161	5,452	5,522	138,48	140,26	0,100	0,106	2,54	2,69	0,146 3	2,397
-162	5,702	5,772	144,83	146,61	0,100	0,106	2,54	2,69	0,152 9	2,506
-163	5,952	6,022	151,18	152,96	0,100	0,106	2,54	2,69	0,159 4	2,612
-164	6,197	6,277	157,40	159,44	0,100	0,106	2,54	2,69	0,166 0	2,720
-165	6,447	6,527	163,75	165,79	0,100	0,106	2,54	2,69	0,172 5	2,827
-166	6,697	6,777	170,10	172,14	0,100	0,106	2,54	2,69	0,179 0	2,933
-167	6,947	7,027	176,45	178,49	0,100	0,106	2,54	2,69	0,185 6	3,041
-168	7,192	7,282	182,68	184,96	0,100	0,106	2,54	2,69	0,192 1	3,148
-169	7,442	7,532	189,03	191,31	0,100	0,106	2,54	2,69	0,198 7	3,256
-170	7,692	7,782	195,38	197,66	0,100	0,106	2,54	2,69	0,205 2	3,363
-171	7,942	8,032	201,73	204,01	0,100	0,106	2,54	2,69	0,211 8	3,471
-172	8,187	8,287	207,95	210,49	0,100	0,106	2,54	2,69	0,218 3	3,577
-173	8,437	8,537	214,30	216,84	0,100	0,106	2,54	2,69	0,224 9	3,685
-174	8,687	8,787	220,65	223,19	0,100	0,106	2,54	2,69	0,231 4	3,792
-175	8,937	9,037	227,00	229,54	0,100	0,106	2,54	2,69	0,237 9	3,898

Table 1 (continued)

Size identi- fication code	Internal diameter				Cross-section				Volume (Ref.)	
	d_1		d_2						in ³	cm ³
	in	mm	in	mm	min.	max.	min.	max.		
-176	9,182	9,292	233,22	236,02	0,100	0,106	2,54	2,69	0,244 5	4,007
-177	9,432	9,542	239,57	242,37	0,100	0,106	2,54	2,69	0,251 0	4,113
-178	9,682	9,792	245,92	248,72	0,100	0,106	2,54	2,69	0,257 6	4,221
*179 to *200	O-ring sizes not assigned									
-201	0,166	0,176	4,22	4,47	0,135	0,143	3,43	3,63	0,014 8	0,243
-202	0,229	0,239	5,82	6,07	0,135	0,143	3,43	3,63	0,017 8	0,292
-203	0,291	0,301	7,39	7,65	0,135	0,143	3,43	3,63	0,020 7	0,339
-204	0,354	0,364	8,99	9,25	0,135	0,143	3,43	3,63	0,023 7	0,388
-205	0,416	0,426	10,57	10,82	0,135	0,143	3,43	3,63	0,026 7	0,438
-206	0,479	0,489	12,17	12,42	0,135	0,143	3,43	3,63	0,029 7	0,487
-207	0,539	0,553	13,69	14,05	0,135	0,143	3,43	3,63	0,032 7	0,536
-208	0,600	0,618	15,24	15,70	0,135	0,143	3,43	3,63	0,035 7	0,585
-209	0,662	0,680	16,81	17,27	0,135	0,143	3,43	3,63	0,038 6	0,633
-210	0,724	0,744	18,39	18,90	0,135	0,143	3,43	3,63	0,041 6	0,682
-211	0,786	0,806	19,96	20,47	0,135	0,143	3,43	3,63	0,044 6	0,731
-212	0,849	0,869	21,56	22,07	0,135	0,143	3,43	3,63	0,047 6	0,780
-213	0,911	0,931	23,14	23,65	0,135	0,143	3,43	3,63	0,050 5	0,828
-214	0,974	0,994	24,74	25,25	0,135	0,143	3,43	3,63	0,053 5	0,877
-215	1,036	1,056	26,31	26,82	0,135	0,143	3,43	3,63	0,056 5	0,926
-216	1,097	1,121	27,86	28,47	0,135	0,143	3,43	3,63	0,059 5	0,975
-217	1,159	1,183	29,44	30,05	0,135	0,143	3,43	3,63	0,062 5	1,024
-218	1,222	1,246	31,04	31,65	0,135	0,143	3,43	3,63	0,065 5	1,073
-219	1,284	1,308	32,61	33,22	0,135	0,143	3,43	3,63	0,068 4	1,121
-220	1,347	1,371	34,21	34,82	0,135	0,143	3,43	3,63	0,071 4	1,170
-221	1,409	1,433	35,79	36,40	0,135	0,143	3,43	3,63	0,074 4	1,219
-222	1,469	1,499	37,31	38,07	0,135	0,143	3,43	3,63	0,077 4	1,268
-223	1,594	1,624	40,49	41,25	0,135	0,143	3,43	3,63	0,083 3	1,365
-224	1,719	1,749	43,66	44,42	0,135	0,143	3,43	3,63	0,089 3	1,463
-225	1,841	1,877	46,76	47,68	0,135	0,143	3,43	3,63	0,095 2	1,560
-226	1,966	2,002	49,94	50,85	0,135	0,143	3,43	3,63	0,101 2	1,658
-227	2,091	2,127	53,11	54,03	0,135	0,143	3,43	3,63	0,107 2	1,757
-228	2,214	2,254	56,24	57,25	0,135	0,143	3,43	3,63	0,113 1	1,853
-229	2,339	2,379	59,41	60,43	0,135	0,143	3,43	3,63	0,119 1	1,952
-230	2,464	2,504	62,59	63,60	0,135	0,143	3,43	3,63	0,125 0	2,048
-231	2,589	2,629	65,76	66,78	0,135	0,143	3,43	3,63	0,131 0	2,147
-232	2,710	2,758	68,83	70,05	0,135	0,143	3,43	3,63	0,137 0	2,245
-233	2,835	2,883	72,01	73,23	0,135	0,143	3,43	3,63	0,142 9	2,342
-234	2,960	3,008	75,18	76,40	0,135	0,143	3,43	3,63	0,148 9	2,440
-235	3,085	3,133	78,36	79,58	0,135	0,143	3,43	3,63	0,154 8	2,537

Table 1 (continued)

Size identi- fication code	Internal diameter				Cross-section				Volume (Ref.)	
	d_1		d_2		in		mm		in ³	cm ³
	in	mm	in	mm	min.	max.	min.	max.		
-236	3,210	3,258	81,53	82,75	0,135	0,143	3,43	3,63	0,160 8	2,635
-237	3,335	3,383	84,71	85,93	0,135	0,143	3,43	3,63	0,166 8	2,733
-238	3,460	3,508	87,88	89,10	0,135	0,143	3,43	3,63	0,172 7	2,830
-239	3,581	3,637	90,96	92,38	0,135	0,143	3,43	3,63	0,178 7	2,928
-240	3,706	3,762	94,13	95,55	0,135	0,143	3,43	3,63	0,184 6	3,025
-241	3,831	3,887	97,31	98,73	0,135	0,143	3,43	3,63	0,190 6	3,123
-242	3,956	4,012	100,48	101,90	0,135	0,143	3,43	3,63	0,196 6	3,222
-243	4,081	4,137	103,66	105,08	0,135	0,143	3,43	3,63	0,202 5	3,318
-244	4,204	4,264	106,78	108,31	0,135	0,143	3,43	3,63	0,208 5	3,417
-245	4,329	4,389	109,96	111,48	0,135	0,143	3,43	3,63	0,214 4	3,513
-246	4,454	4,514	113,13	114,66	0,135	0,143	3,43	3,63	0,220 4	3,612
-247	4,579	4,639	116,31	117,83	0,135	0,143	3,43	3,63	0,226 3	3,708
-248	4,704	4,764	119,48	121,01	0,135	0,143	3,43	3,63	0,232 3	3,807
-249	4,824	4,894	122,53	124,31	0,135	0,143	3,43	3,63	0,238 3	3,905
-250	4,949	5,019	125,70	127,48	0,135	0,143	3,43	3,63	0,244 2	4,002
-251	5,074	5,144	128,88	130,66	0,135	0,143	3,43	3,63	0,250 2	4,100
-252	5,199	5,269	132,05	133,83	0,135	0,143	3,43	3,63	0,256 1	4,197
-253	5,324	5,394	135,23	137,01	0,135	0,143	3,43	3,63	0,262 1	4,295
-254	5,449	5,519	138,40	140,18	0,135	0,143	3,43	3,63	0,268 1	4,393
-255	5,574	5,644	141,58	143,36	0,135	0,143	3,43	3,63	0,274 0	4,490
-256	5,699	5,769	144,75	146,53	0,135	0,143	3,43	3,63	0,280 0	4,588
-257	5,824	5,894	147,93	149,71	0,135	0,143	3,43	3,63	0,285 9	4,685
-258	5,949	6,019	151,10	152,88	0,135	0,143	3,43	3,63	0,291 9	4,783
-259	6,194	6,274	157,33	159,36	0,135	0,143	3,43	3,63	0,303 8	4,978
-260	6,444	6,524	163,68	165,71	0,135	0,143	3,43	3,63	0,315 7	5,173
-261	6,694	6,774	170,03	172,06	0,135	0,143	3,43	3,63	0,327 7	5,370
-262	6,944	7,024	176,38	178,41	0,135	0,143	3,43	3,63	0,339 6	5,565
-263	7,189	7,279	182,60	184,89	0,135	0,143	3,43	3,63	0,351 5	5,760
-264	7,439	7,529	188,95	191,24	0,135	0,143	3,43	3,63	0,363 4	5,955
-265	7,689	7,779	195,30	197,59	0,135	0,143	3,43	3,63	0,375 3	6,150
-266	7,939	8,029	201,65	203,94	0,135	0,143	3,43	3,63	0,387 2	6,345
-267	8,184	8,284	207,87	210,41	0,135	0,143	3,43	3,63	0,399 2	6,542
-268	8,434	8,534	214,22	216,76	0,135	0,143	3,43	3,63	0,411 1	6,737
-269	8,684	8,784	220,57	223,11	0,135	0,143	3,43	3,63	0,423 0	6,932
-270	8,934	9,034	226,92	229,46	0,135	0,143	3,43	3,63	0,434 9	7,127
-271	9,179	9,289	233,15	235,94	0,135	0,143	3,43	3,63	0,446 8	7,322
-272	9,429	9,539	239,50	242,29	0,135	0,143	3,43	3,63	0,458 8	7,518
-273	9,679	9,789	245,85	248,64	0,135	0,143	3,43	3,63	0,470 7	7,713
-274	9,929	10,039	252,20	254,99	0,135	0,143	3,43	3,63	0,482 6	7,908
-275	10,429	10,539	264,90	267,69	0,135	0,143	3,43	3,63	0,506 4	8,298

Table 1 (continued)

Size identi- fication code	Internal diameter				Cross-section				Volume (Ref.)	
	d_1		d_2		d_2		d_2		in ³	cm ³
	in	mm	in	mm	in	mm	in	mm		
min.	max.	min.	max.	min.	max.	min.	max.			
-276	10,919	11,049	277,34	280,64	0,135	0,143	3,43	3,63	0,530 3	8,690
-277	11,419	11,549	290,04	293,34	0,135	0,143	3,43	3,63	0,554 1	9,080
-278	11,919	12,049	302,74	306,04	0,135	0,143	3,43	3,63	0,577 9	9,470
-279	12,919	13,049	328,14	331,44	0,135	0,143	3,43	3,63	0,625 6	10,252
-280	13,919	14,049	353,54	356,84	0,135	0,143	3,43	3,63	0,673 3	11,033
-281	14,919	15,049	378,94	382,24	0,135	0,143	3,43	3,63	0,721 0	11,815
-282	15,880	16,030	403,35	407,16	0,135	0,143	3,43	3,63	0,767 2	12,572
-283	16,875	17,035	428,62	432,69	0,135	0,143	3,43	3,63	0,814 9	13,354
-284	17,870	18,040	453,90	458,22	0,135	0,143	3,43	3,63	0,862 6	14,136
*285 to *308	O-ring sizes not assigned									
-309	0,407	0,417	10,34	10,59	0,205	0,215	5,21	5,46	0,067 7	1,109
-310	0,470	0,480	11,94	12,19	0,205	0,215	5,21	5,46	0,074 5	1,221
-311	0,530	0,544	13,46	13,82	0,205	0,215	5,21	5,46	0,081 3	1,332
-312	0,591	0,609	15,01	15,47	0,205	0,215	5,21	5,46	0,088 1	1,444
-313	0,653	0,671	16,59	17,04	0,205	0,215	5,21	5,46	0,094 9	1,555
-314	0,715	0,735	18,16	18,67	0,205	0,215	5,21	5,46	0,101 7	1,667
-315	0,777	0,797	19,74	20,24	0,205	0,215	5,21	5,46	0,108 5	1,778
-316	0,840	0,860	21,34	21,84	0,205	0,215	5,21	5,46	0,115 3	1,889
-317	0,902	0,922	22,91	23,42	0,205	0,215	5,21	5,46	0,122 1	2,001
-318	0,965	0,985	24,51	25,02	0,205	0,215	5,21	5,46	0,128 9	2,112
-319	1,027	1,047	26,09	26,59	0,205	0,215	5,21	5,46	0,135 7	2,224
-320	1,088	1,112	27,64	28,24	0,205	0,215	5,21	5,46	0,142 5	2,335
-321	1,150	1,174	29,21	29,82	0,205	0,215	5,21	5,46	0,149 3	2,447
-322	1,213	1,237	30,81	31,42	0,205	0,215	5,21	5,46	0,156 1	2,558
-323	1,275	1,299	32,38	32,99	0,205	0,215	5,21	5,46	0,162 9	2,669
-324	1,338	1,362	33,99	34,59	0,205	0,215	5,21	5,46	0,169 7	2,781
-325	1,460	1,490	37,08	37,85	0,205	0,215	5,21	5,46	0,183 3	3,004
-326	1,585	1,615	40,26	41,02	0,205	0,215	5,21	5,46	0,197 0	3,228
-327	1,710	1,740	43,43	44,20	0,205	0,215	5,21	5,46	0,210 6	3,451
-328	1,835	1,865	46,61	47,37	0,205	0,215	5,21	5,46	0,224 2	3,674
-329	1,957	1,993	49,71	50,62	0,205	0,215	5,21	5,46	0,237 8	3,897
-330	2,082	2,118	52,88	53,80	0,205	0,215	5,21	5,46	0,251 4	4,120
-331	2,207	2,243	56,06	56,97	0,205	0,215	5,21	5,46	0,265 0	4,343
-332	2,332	2,368	59,23	60,15	0,205	0,215	5,21	5,46	0,278 6	4,565
-333	2,455	2,495	62,36	63,37	0,205	0,215	5,21	5,46	0,292 2	4,788
-334	2,580	2,620	65,53	66,55	0,205	0,215	5,21	5,46	0,305 8	5,011
-335	2,705	2,745	68,71	69,72	0,205	0,215	5,21	5,46	0,319 4	5,234

Table 1 (continued)

Size identi- fication code	Internal diameter				Cross-section				Volume (Ref.)	
	d_1		d_2		in		mm		in ³	cm ³
	in	mm	in	mm	min.	max.	min.	max.		
-336	2,830	2,870	71,88	72,90	0,205	0,215	5,21	5,46	0,333 0	5,457
-337	2,951	2,999	74,96	76,17	0,205	0,215	5,21	5,46	0,346 6	5,680
-338	3,076	3,124	78,13	79,35	0,205	0,215	5,21	5,46	0,360 2	5,903
-339	3,201	3,249	81,31	82,52	0,205	0,215	5,21	5,46	0,373 8	6,125
-340	3,326	3,374	84,48	85,70	0,205	0,215	5,21	5,46	0,387 4	6,348
-341	3,451	3,499	87,66	88,87	0,205	0,215	5,21	5,46	0,401 0	6,571
-342	3,572	3,628	90,73	92,15	0,205	0,215	5,21	5,46	0,414 6	6,796
-343	3,697	3,753	93,90	95,33	0,205	0,215	5,21	5,46	0,428 2	7,017
-344	3,822	3,878	97,08	98,50	0,205	0,215	5,21	5,46	0,441 8	7,240
-345	3,947	4,003	100,25	101,68	0,205	0,215	5,21	5,46	0,455 4	7,463
-346	4,072	4,128	103,43	104,85	0,205	0,215	5,21	5,46	0,469 0	7,686
-347	4,195	4,255	106,55	108,08	0,205	0,215	5,21	5,46	0,482 6	7,908
-348	4,320	4,380	109,73	111,25	0,205	0,215	5,21	5,46	0,496 2	8,131
-349	4,445	4,505	112,90	114,43	0,205	0,215	5,21	5,46	0,509 8	8,354
-350	4,570	4,630	116,08	117,60	0,205	0,215	5,21	5,46	0,523 4	8,577
-351	4,695	4,755	119,25	120,77	0,205	0,215	5,21	5,46	0,537 0	8,800
-352	4,820	4,880	122,43	123,95	0,205	0,215	5,21	5,46	0,550 6	9,023
-353	4,938	5,012	125,43	127,30	0,205	0,215	5,21	5,46	0,564 2	9,246
-354	5,063	5,137	128,60	130,48	0,205	0,215	5,21	5,46	0,577 8	9,468
-355	5,188	5,262	131,78	133,65	0,205	0,215	5,21	5,46	0,591 4	9,691
-356	5,313	5,387	134,95	136,83	0,205	0,215	5,21	5,46	0,605 0	9,914
-357	5,438	5,512	138,13	140,00	0,205	0,215	5,21	5,46	0,618 6	10,137
-358	5,563	5,637	141,30	143,18	0,205	0,215	5,21	5,46	0,632 2	10,360
-359	5,688	5,762	144,48	146,35	0,205	0,215	5,21	5,46	0,645 8	10,583
-360	5,813	5,887	147,65	149,53	0,205	0,215	5,21	5,46	0,659 4	10,806
-361	5,938	6,012	150,83	152,70	0,205	0,215	5,21	5,46	0,673 0	11,029
-362	6,185	6,265	157,10	159,13	0,205	0,215	5,21	5,46	0,700 2	11,474
-363	6,435	6,515	163,45	165,48	0,205	0,215	5,21	5,46	0,727 4	11,920
-364	6,685	6,765	169,80	171,83	0,205	0,215	5,21	5,46	0,754 6	12,366
-365	6,935	7,015	176,15	178,18	0,205	0,215	5,21	5,46	0,781 8	12,811
-366	7,180	7,270	182,37	184,66	0,205	0,215	5,21	5,46	0,809 0	13,257
-367	7,430	7,520	188,72	191,01	0,205	0,215	5,21	5,46	0,836 2	13,703
-368	7,680	7,770	195,07	197,36	0,205	0,215	5,21	5,46	0,863 4	14,149
-369	7,930	8,020	201,42	203,71	0,205	0,215	5,21	5,46	0,890 6	14,594
-370	8,175	8,275	207,64	210,18	0,205	0,215	5,21	5,46	0,917 8	15,040
-371	8,425	8,525	214,00	216,53	0,205	0,215	5,21	5,46	0,945 0	15,486
-372	8,675	8,775	220,34	222,89	0,205	0,215	5,21	5,46	0,972 2	15,932
-373	8,925	9,025	226,69	229,23	0,205	0,215	5,21	5,46	0,999 4	16,377
-374	9,170	9,280	232,92	235,71	0,205	0,215	5,21	5,46	1,026 6	16,823
-375	9,420	9,530	239,27	242,06	0,205	0,215	5,21	5,46	1,053 8	17,269

Table 1 (continued)

Size identi- fication code	Internal diameter				Cross-section				Volume (Ref.)	
	d_1		d_2						in ³	cm ³
	in	mm	in	mm	min.	max.	min.	max.		
-376	9,670	9,780	245,62	248,41	0,205	0,215	5,21	5,46	1,081 1	17,716
-377	9,920	10,030	251,97	254,76	0,205	0,215	5,21	5,46	1,108 3	18,162
-378	10,415	10,535	264,54	267,59	0,205	0,215	5,21	5,46	1,162 7	19,053
-379	10,915	11,035	277,24	280,29	0,205	0,215	5,21	5,46	1,217 1	19,945
-380	11,410	11,540	289,81	293,12	0,205	0,215	5,21	5,46	1,271 5	20,836
-381	11,910	12,040	302,51	305,82	0,205	0,215	5,21	5,46	1,325 9	21,728
-382	12,910	13,040	327,91	331,22	0,205	0,215	5,21	5,46	1,434 7	23,511
-383	13,905	14,045	353,19	356,74	0,205	0,215	5,21	5,46	1,543 5	25,293
-384	14,905	15,045	378,59	382,14	0,205	0,215	5,21	5,46	1,652 3	27,076
-385	15,880	16,030	403,35	407,16	0,205	0,215	5,21	5,46	1,759 0	28,825
-386	16,875	17,035	428,62	432,69	0,205	0,215	5,21	5,46	1,867 8	30,608
-387	17,870	18,040	453,90	458,22	0,205	0,215	5,21	5,46	1,976 6	32,391
-388	18,865	19,045	479,17	483,74	0,205	0,215	5,21	5,46	2,085 4	34,174
-389	19,860	20,050	504,44	509,27	0,205	0,215	5,21	5,46	2,194 2	35,957
-390	20,860	21,050	529,84	534,67	0,205	0,215	5,21	5,46	2,303 0	37,739
-391	21,855	22,055	555,12	560,20	0,205	0,215	5,21	5,46	2,411 8	39,522
-392	22,835	23,045	580,01	585,34	0,205	0,215	5,21	5,46	2,519 0	41,279
-393	23,830	24,050	605,28	610,87	0,205	0,215	5,21	5,46	2,627 8	43,062
-394	24,825	25,055	630,56	636,40	0,205	0,215	5,21	5,46	2,736 6	44,845
-395	25,820	26,060	655,83	661,92	0,205	0,215	5,21	5,46	2,845 4	46,628
-396 to -424	O-ring sizes not assigned									
-425	4,442	4,508	112,83	114,50	0,269	0,281	6,83	7,14	0,886 3	14,524
-426	4,567	4,633	116,00	117,68	0,269	0,281	6,83	7,14	0,909 7	14,907
-427	4,692	4,758	119,18	120,85	0,269	0,281	6,83	7,14	0,933 0	15,289
-428	4,817	4,883	122,35	124,03	0,269	0,281	6,83	7,14	0,956 3	15,671
-429	4,938	5,012	125,43	127,30	0,269	0,281	6,83	7,14	0,979 6	16,053
-430	5,063	5,137	128,60	130,48	0,269	0,281	6,83	7,14	1,003 0	16,436
-431	5,188	5,262	131,78	133,65	0,269	0,281	6,83	7,14	1,026 3	16,818
-432	5,313	5,387	134,95	136,83	0,269	0,281	6,83	7,14	1,049 6	17,200
-433	5,438	5,512	138,13	140,00	0,269	0,281	6,83	7,14	1,072 9	17,582
-434	5,563	5,637	141,30	143,18	0,269	0,281	6,83	7,14	1,096 3	17,965
-435	5,688	5,762	144,48	146,35	0,269	0,281	6,83	7,14	1,119 6	18,347
-436	5,813	5,887	147,65	149,53	0,269	0,281	6,83	7,14	1,142 9	18,729
-437	5,938	6,012	150,83	152,70	0,269	0,281	6,83	7,14	1,166 2	19,111
-438	6,185	6,265	157,10	159,13	0,269	0,281	6,83	7,14	1,212 9	19,876
-439	6,435	6,515	163,45	165,48	0,269	0,281	6,83	7,14	1,259 5	20,640
-440	6,685	6,765	169,80	171,83	0,269	0,281	6,83	7,14	1,306 2	21,405

Table 1 (continued)

Size identi- fication code	Internal diameter				Cross-section				Volume (Ref.)	
	d_1		d_2		in		mm		in ³	cm ³
	in	mm	in	mm	min.	max.	min.	max.		
-441	6,935	7,015	176,15	178,18	0,269	0,281	6,83	7,14	1,352 8	22,168
-442	7,180	7,270	182,37	184,66	0,269	0,281	6,83	7,14	1,399 5	22,934
-443	7,430	7,520	188,72	191,01	0,269	0,281	6,83	7,14	1,446 1	23,697
-444	7,680	7,770	195,07	197,36	0,269	0,281	6,83	7,14	1,492 8	24,463
-445	7,930	8,020	201,42	203,71	0,269	0,281	6,83	7,14	1,539 4	25,226
-446	8,420	8,530	213,87	216,66	0,269	0,281	6,83	7,14	1,632 7	26,755
-447	8,920	9,030	226,57	229,36	0,269	0,281	6,83	7,14	1,726 0	28,284
-448	9,420	9,530	239,27	242,06	0,269	0,281	6,83	7,14	1,819 3	29,813
-449	9,920	10,030	251,97	254,76	0,269	0,281	6,83	7,14	1,912 6	31,342
-450	10,415	10,535	264,54	267,59	0,269	0,281	6,83	7,14	2,005 9	32,871
-451	10,915	11,035	277,24	280,29	0,269	0,281	6,83	7,14	2,099 2	34,400
-452	11,415	11,535	289,94	292,99	0,269	0,281	6,83	7,14	2,192 5	35,929
-453	11,915	12,035	302,64	305,69	0,269	0,281	6,83	7,14	2,285 8	37,458
-454	12,415	12,535	315,34	318,39	0,269	0,281	6,83	7,14	2,379 1	38,987
-455	12,915	13,035	328,04	331,09	0,269	0,281	6,83	7,14	2,472 4	40,515
-456	13,405	13,545	340,49	344,04	0,269	0,281	6,83	7,14	2,565 7	42,044
-457	13,905	14,045	353,19	356,74	0,269	0,281	6,83	7,14	2,659 0	43,573
-458	14,405	14,545	365,89	369,44	0,269	0,281	6,83	7,14	2,752 3	45,102
-459	14,905	15,045	378,59	382,14	0,269	0,281	6,83	7,14	2,845 6	46,631
-460	15,405	15,545	391,29	394,84	0,269	0,281	6,83	7,14	2,938 9	48,160
-461	15,880	16,030	403,35	407,16	0,269	0,281	6,83	7,14	3,028 5	49,628
-462	16,380	16,530	416,05	419,86	0,269	0,281	6,83	7,14	3,121 8	51,157
-463	16,875	17,035	428,62	432,69	0,269	0,281	6,83	7,14	3,215 1	52,686
-464	17,370	17,540	441,20	445,52	0,269	0,281	6,83	7,14	3,308 4	54,215
-465	17,870	18,040	453,90	458,22	0,269	0,281	6,83	7,14	3,401 7	55,744
-466	18,370	18,540	466,60	470,92	0,269	0,281	6,83	7,14	3,495 0	57,273
-467	18,865	19,045	479,17	483,74	0,269	0,281	6,83	7,14	3,588 3	58,802
-468	19,365	19,545	491,87	496,44	0,269	0,281	6,83	7,14	3,681 6	60,331
-469	19,860	20,050	504,44	509,27	0,269	0,281	6,83	7,14	3,774 9	61,860
-470	20,860	21,050	529,84	534,67	0,269	0,281	6,83	7,14	3,961 5	64,917
-471	21,855	22,055	555,12	560,18	0,269	0,281	6,83	7,14	4,148 1	67,975
-472	22,835	23,045	580,01	585,34	0,269	0,281	6,83	7,14	4,331 9	70,987
-473	23,830	24,050	605,28	610,87	0,269	0,281	6,83	7,14	4,518 4	74,043
-474	24,825	25,055	630,55	636,40	0,269	0,281	6,83	7,14	4,705 0	77,101
-475	25,820	26,060	655,83	661,92	0,269	0,281	6,83	7,14	4,891 6	80,159

**Table 2 — Inside diameters, cross-sections and tolerances
for sealing straight thread tube-fitting bosses**

Size identi- fication code	Nominal tube size		Internal diameter				Cross-section				Volume (Ref.)	
			d_1		d_2		in		mm		in ³	cm ³
	in	mm	min.	max.	min.	max.	min.	max.	min.	max.		
-901	0,093 8	2,383	0,180	0,190	4,57	4,83	0,053	0,059	1,35	1,50	0,001 9	0,031
-902	0,125	3,18	0,234	0,244	5,94	6,20	0,061	0,067	1,55	1,70	0,003 1	0,051
-903	0,187 5	4,763	0,296	0,306	7,52	7,77	0,061	0,067	1,55	1,70	0,003 7	0,061
-904	0,250	6,35	0,346	0,356	8,79	9,04	0,069	0,075	1,75	1,90	0,005 4	0,088
-905	0,312 5	7,938	0,409	0,419	10,39	10,64	0,069	0,075	1,75	1,90	0,006 2	0,102
-906	0,375	9,53	0,463	0,473	11,76	12,01	0,075	0,081	1,90	2,06	0,008 2	0,134
-907	0,437 5	11,11	0,523	0,537	13,28	13,64	0,079	0,085	2,01	2,16	0,010 2	0,167
-908	0,500	12,70	0,635	0,653	16,13	16,59	0,084	0,090	2,13	2,29	0,013 7	0,225
-909	0,562 5	14,28	0,697	0,715	17,70	18,16	0,094	0,100	2,39	2,54	0,018 6	0,305
-910	0,625	15,88	0,746	0,764	18,95	19,41	0,094	0,100	2,39	2,54	0,019 8	0,324
-911	0,687 5	17,46	0,854	0,872	21,69	22,15	0,112	0,120	2,84	3,05	0,032 5	0,533
-912	0,750	19,05	0,915	0,933	23,24	23,70	0,112	0,120	2,84	3,05	0,034 5	0,565
-913	0,812 5	20,64	0,976	0,996	24,79	25,30	0,112	0,120	2,84	3,05	0,036 6	0,600
-914	0,875	22,23	1,037	1,057	26,34	26,85	0,112	0,120	2,84	3,05	0,038 6	0,633
-916	1,000	25,40	1,161	1,181	29,49	30,00	0,112	0,120	2,84	3,05	0,042 7	0,700
-918	1,125	28,58	1,343	1,367	34,11	34,72	0,112	0,120	2,84	3,05	0,048 8	0,800
-920	1,250	31,75	1,461	1,489	37,11	37,82	0,114	0,122	2,90	3,10	0,054 7	0,896
-924	1,500	38,10	1,706	1,734	43,33	44,04	0,114	0,122	2,90	3,10	0,063 1	1,034
-928	1,750	44,45	2,072	2,108	52,63	53,54	0,114	0,122	2,90	3,10	0,075 9	1,244
-932	2,000	50,80	2,319	2,355	58,90	59,82	0,114	0,122	2,90	3,10	0,084 3	1,381

1

ICS 49.080

Price based on 13 pages