**Earth-moving machinery — Hazard
detection systems and visual aids —
Performance requirements and tests**

*Engins de terrassement — Dispositifs de détection des risques et d'aide
visuelle — Exigences de performances et essais*



Reference number
ISO 16001:2008(E)

© ISO 2008

PDF disclaimer

This PDF file may contain embedded typefaces. In accordance with Adobe's licensing policy, this file may be printed or viewed but shall not be edited unless the typefaces which are embedded are licensed to and installed on the computer performing the editing. In downloading this file, parties accept therein the responsibility of not infringing Adobe's licensing policy. The ISO Central Secretariat accepts no liability in this area.

Adobe is a trademark of Adobe Systems Incorporated.

Details of the software products used to create this PDF file can be found in the General Info relative to the file; the PDF-creation parameters were optimized for printing. Every care has been taken to ensure that the file is suitable for use by ISO member bodies. In the unlikely event that a problem relating to it is found, please inform the Central Secretariat at the address given below.



COPYRIGHT PROTECTED DOCUMENT

© ISO 2008

All rights reserved. Unless otherwise specified, no part of this publication may be reproduced or utilized in any form or by any means, electronic or mechanical, including photocopying and microfilm, without permission in writing from either ISO at the address below or ISO's member body in the country of the requester.

ISO copyright office
Case postale 56 • CH-1211 Geneva 20
Tel. + 41 22 749 01 11
Fax + 41 22 749 09 47
E-mail copyright@iso.org
Web www.iso.org

Published in Switzerland

Contents

Page

Foreword.....	iv
Introduction	v
1 Scope	1
2 Normative references	1
3 Terms and definitions.....	2
4 Performance requirements and tests	3
4.1 General requirements.....	3
4.2 Location and fixing of HDS and VA devices	4
4.3 Operator station devices.....	4
4.4 System activation and initial check	5
4.5 HDS detection and response time	5
4.6 Operational integrity.....	5
4.7 System disablement	6
4.8 Physical environment and operating conditions	6
5 Marking and identification	6
6 Operator's manual	6
Annex A (informative) Selection of HDS and VA.....	8
Annex B (normative) Test procedure for closed-circuit television (CCTV) systems — Additional performance requirements and tests	13
Annex C (normative) Test procedure for radar sensors	20
Annex D (normative) Test procedure for ultrasonic detection systems	25
Annex E (normative) Test procedure for ultrasonic transponder systems	33
Annex F (informative) Test procedure for electromagnetic (EM) signal transceiver systems.....	43
Bibliography	50

Foreword

ISO (the International Organization for Standardization) is a worldwide federation of national standards bodies (ISO member bodies). The work of preparing International Standards is normally carried out through ISO technical committees. Each member body interested in a subject for which a technical committee has been established has the right to be represented on that committee. International organizations, governmental and non-governmental, in liaison with ISO, also take part in the work. ISO collaborates closely with the International Electrotechnical Commission (IEC) on all matters of electrotechnical standardization.

International Standards are drafted in accordance with the rules given in the ISO/IEC Directives, Part 2.

The main task of technical committees is to prepare International Standards. Draft International Standards adopted by the technical committees are circulated to the member bodies for voting. Publication as an International Standard requires approval by at least 75 % of the member bodies casting a vote.

Attention is drawn to the possibility that some of the elements of this document may be the subject of patent rights. ISO shall not be held responsible for identifying any or all such patent rights.

ISO 16001 was prepared by Technical Committee ISO/TC 127, *Earth-moving machinery*, Subcommittee SC 2, *Safety requirements and human factors*.

Introduction

This International Standard outlines test procedures and sets criteria for the development of hazard detection systems (HDS) and visual aids (VA) for detecting people.

Proper job-site organization, operator training and the application of relevant vision standards (ISO 5006 and ISO 14401) address the safety of people on job sites. In some cases, vision of the working area cannot be achieved either by the operator's direct view or indirect view using mirrors. In such cases, operator awareness can be improved by the use of HDS and VA.

HDS and VA provide information to the operator as to whether a person or object is in the path of the machine, primarily during rearward movement.

It is essential to note that HDS and VA have both advantages and disadvantages. There is no device that works perfectly in all situations. It is especially important that the shortcomings of HDS and VA be recognised and known to system users. The advantages and disadvantages of selected devices are summarized in Annex A.

Earth-moving machinery — Hazard detection systems and visual aids — Performance requirements and tests

1 Scope

This International Standard specifies general requirements and describes methods for evaluating and testing the performance of hazard detection systems (HDS) and visual aids (VA) used on earth-moving machines. It covers the following aspects:

- detection of people in the detection zone;
- visual and/or audible warning(s) to the operator and/or to the persons in the detection zone;
- operational reliability of the system;
- compatibility and environmental specifications of the system.

It is applicable to machines as defined in ISO 6165. HDS and/or VA can be used to augment the operator's direct vision (see ISO 5006) or indirect vision using mirrors (see ISO 14401) or to provide additional means of hazard detection, for example, where ergonomic considerations limit the effectiveness of direct vision, e.g. to avoid repeated turning of the head and upper body.

2 Normative references

The following referenced documents are indispensable for the application of this document. For dated references, only the edition cited applies. For undated references, the latest edition of the referenced document (including any amendments) applies.

ISO 6165, *Earth-moving machinery — Basic types — Identification and terms and definitions*

ISO 6394, *Earth-moving machinery — Determination of emission sound pressure level at operator's position — Stationary test conditions*¹⁾

ISO 9533, *Earth-moving machinery — Machine-mounted forward and reverse audible warning alarm — Sound test method*

ISO 13766, *Earth-moving machinery — Electromagnetic compatibility*

ISO 15998²⁾, *Earth-moving machinery — Machine-control systems (MCS) using electronic components — Performance criteria and tests for functional safety*

1) To be published. (Revision of ISO 6394:1998)

2) To be published.

3 Terms and definitions

For the purposes of this document, the following terms and definitions apply.

3.1

hazard detection system

HDS

system that both detects hazards and warns the operator and/or the person on the ground

NOTE The system generally includes a sensing device, warning device and evaluation device.

3.1.1

sensing device

HDS component that detects a test body in the detection zone

3.1.2

warning device

HDS component that transmits information to the operator and/or to persons in the detection zone by visual and/or audible signals

3.1.3

evaluation device

HDS component or components that analyse the signals and information transmitted from the sensing device and transform the corresponding signal to the warning device

3.2

visual aid

VA

system that provides visual information without warning

NOTE The system generally includes a monitor and camera.

3.2.1

monitor

VA component that provides a visual image of the detection zone on a screen

3.2.2

camera

VA component that transmits to the monitor an image of the detection zone

3.3

detection zone

zone within which a test body is detected by an HDS or is shown by a VA

3.4

test body

person or a standard measuring unit representative of a person, used to test the geometry and size of the detection zone

NOTE Depending on the system used, test bodies can be varied (see Annexes B to F).

3.5

self-testing

capability of the system to self-check continuously and immediately to inform the operator, audibly and/or visually, of a failure

3.6

detection time

time required for a hazard detection system to detect the test body in the detection zone and activate the signal output

3.7**stand-by**

operation mode whereby the hazard detection and visual aid systems are active, but no information is transmitted by the warning device or monitor

3.8**job-site organization**

rules and procedures for managing the working together of machines and people at a job site

EXAMPLE Safety instructions, traffic patterns, restricted areas, operator training, machine and vehicle markings, communications systems.

4 Performance requirements and tests**4.1 General requirements****4.1.1 Test of detection zone**

The test method shall be performed on a system that is either fitted to the machine or to a representative configuration in accordance with Annexes B to F.

4.1.2 Test body requirements

The test body requirements are specified in Annexes B to F.

4.1.3 Environmental conditions

The test shall be undertaken under the following environmental conditions:

- temperature ($23\text{ °C} \pm 5\text{ °C}$);
- relative humidity ($60\% \pm 25\%$).

The test shall not be affected by reflections from surrounding walls, auxiliary test equipment or other objects. For further details, see Annexes B to F.

4.1.4 Evaluation of test results**4.1.4.1 Detection**

Detection shall take place unambiguously with an uninterrupted sequence of the signal or information appropriate to the warning range. For further details, see Annexes B to F.

4.1.4.2 Evaluation of false signals

False signals, such as the following, should be minimized:

- when a machine approaches a ramp;
- from objects outside the detection zone;
- from weather conditions of fog, snow, rain, wind, dust, etc.

4.2 Location and fixing of HDS and VA devices

Devices shall be located and arranged on the machine in accordance with the specification of the device manufacturer so that

- the device does not restrict any function or operation of the machine,
- the device is protected against external damage,
- the device is affixed to the machine so as to deter unauthorized disablement and/or removal,
- the device is mounted so as to limit exposure to, or amplification of, dynamic loads, temperature, shock or vibration that could prematurely damage the device,
- the attachment and fixings of HDS and VA devices do not affect the integrity of the protective structures, e.g. rollover protective structures (ROPS), and
- the device is designed and mounted to permit routine service access from the ground or from a service platform so that the intended performance is maintained.

4.3 Operator station devices

4.3.1 Location of monitor

The monitor shall be located within the operator's view. Restriction of the operator's view of the working area or of the machine working equipment shall be minimized.

When the monitor is used to cover the area behind the machine, the system shall be configured to provide a reverse image on the monitor.

In order to see a person at the maximum distance of the detection zone, the monitor shall display the height of a fifth percentile person (see ISO 3411) such that the image is 7 mm on the monitor. The monitor should be within 1,2 m of the operator's eye point. The monitor shall be positioned so as to minimize the glare caused by direct sunlight.

NOTE Factors that influence an operator's ability to detect a person on the monitor are the position of the monitor within the cab, the distance of the operator from the monitor, the size of monitor, the ambient lighting, the lens on the camera and the distance of the object from the lens.

4.3.2 Warning devices

Both audible and visual warning devices are required for an HDS. These devices shall provide indications to the operator and may provide indications to workers and other persons present at the work site.

4.3.2.1 Audible devices

Operator station warning devices shall be set at, or shall automatically adjust to, a level at least 3 dB higher than the ambient noise level as measured at maximum governed speed under no load.

All in-cab warnings should be selected so that they are clearly audible at the operator station. The warning signal should be in the frequency range 500 Hz to 2 500 Hz.

In-cab alarms shall be distinguishable by the operator from other sounds (i.e. warnings or machinery noise) in the operator's station.

NOTE This can be achieved by varying the spectral characteristics and the temporal distribution of the signals (see ISO 9533).

4.3.2.2 Visual devices

A green system-status light shall inform the operator that the system is powered and functional. The light may be continuous or turn off after the function check is completed.

The warning signals in the cab shall be mounted in direct view of the operator and be visible in direct sunlight. The warning signals shall be distinguishable from other instrument panel warnings; the most severe warning shall be a flashing red light.

4.3.2.3 External warning devices

If an external warning device is fitted as part of the HDS, then the external alarms shall comply with ISO 9533.

External visual warning devices, when fitted, shall be visible to people in the detection zone.

4.4 System activation and initial check

The system shall activate automatically on engine start, perform an initial system check and give a proper function indication. For visual aid systems, the indication of proper function shall be by a clear image of the detection zone on the monitor.

In the case of a HDS malfunction, a warning shall be given to the operator.

The system may enter stand-by mode until the relevant machine movement mode is selected.

If multiple cameras or sensors are fitted, the system shall automatically select the camera or sensor appropriate to the direction of travel.

4.5 HDS detection and response time

HDS detection and response time shall not exceed 300 ms after activation of the system or after waking from stand-by. The system detection and response time is the time from which the operator selects the relevant machine movement mode until the system is able to detect a person.

4.6 Operational integrity

4.6.1 General

The operational integrity of the HDS and VA shall comply with ISO 15998 and ISO 13766.

4.6.2 Continuous self-checking

The availability of an image of the detection zone on the monitor is sufficient as a monitoring function for a VA. An HDS shall have a permanent monitoring function including at least the following:

- a) an operating indication light (green);
- b) a stand-by indication light (flashing amber or green) (see 4.3.2.2);
- c) a visual and/or audible failure signal if the operation of the system is impaired, including monitoring of each link on the HDS, which includes the monitoring of all machine signals used for system operation, i.e.
 - wire break,
 - short-circuit,
 - time management (if applicable),

- signal output and signal input, and
- checking of the system.

4.7 System disablement

It shall not be possible to disable the warning device simply by switching it off. The activation of the warning device shall be so designed and installed that its reliable operation cannot easily be altered by the operator. Any exceptions shall be specified in accordance with Annexes B to F.

4.8 Physical environment and operating conditions

The HDS and VA shall comply with ISO 15998 in respect of the physical environment and operating conditions with the following exceptions:

- temperature: -30 °C to $+60\text{ °C}$;
- vibration: -10 g over 5 Hz to 100 Hz ($4,5\text{ g}$ for in-cab components);
- shock: -10 g for exterior components ($4,5\text{ g}$ for in-cab components).

NOTE The objective is to achieve, as the state-of-the-art progresses, the temperature, vibration and shock requirements of ISO 15998.

5 Marking and identification

Each device shall bear legibly and indelibly the following information:

- manufacturer;
- type/model;
- product/serial number;
- regulatory markings, as required.

6 Operator's manual

HDS and VA shall be supplied with an operator's manual containing installation, technical and safety instructions for the intended use of such systems, as follows:

- description of systems function;
- detailed description of performance and operating limits — in particular, the effect of different mounting heights and angles;
- information for job-site organization;
- weather limitations;
- topography limitations;
- instructions for maintenance;
- instructions for installation and assembly, including mounting location;

- instructions for activation;
- description of controls;
- instructions concerning safe operation;
- instructions for performance verification;
- instructions on action in the event of malfunction;
- information for connection with other components (if required);
- regulatory certifications, e.g. EMC and RF conformity test certifications (if required by the regional regulatory body);
- countries for which type approval has been achieved (if required);
- recommended routine for regular performance checks of the HDS and VA by the user;
- electrical supply requirements.

Annex A **(informative)**

Selection of HDS and VA

A.1 Introduction

HDS and VA may be used to supplement the direct and indirect vision of the operator. In selecting HDS and VA, consideration should be given to the operator's information needs and his ability to respond to them. The operator has many demands on his attention and when selecting HDS and VA, careful consideration should be given to the form of information, visual or audible, that will be of most use to the operator when a hazard occurs. There is always a risk that visual information will pass unnoticed. Audible information will catch the attention of the operator but will be ignored if too many unwanted warnings are provided.

It is essential to note that HDS and VA have both advantages and disadvantages. There is no device that works perfectly to cover the desired detection zone in all situations. It is especially important that the shortcomings of HDS and VA be recognized and known to system users. However some of these may be offset by combining two or more technologies. The advantages and disadvantages of some techniques are summarized in Table A.1.

The basic technologies are being continuously improved. Therefore, some of the shortcomings could be addressed by future developments.

A.2 Consideration of the functional aspects of HDS and VA

A.2.1 General

The following machine functions, and operational and environmental aspects, of the HDS and VA should be considered.

A.2.2 Operator needs and ability to interface and use the system

These needs are, for example,

- tolerance of false alarm signals,
- time and frequency of observation for visual systems,
- potential for information overload where multiple HDS and VA are used,
- human factors, e.g. reaction time,
- training and instruction, and
- type of warning required by the operator or person in detection zone.

A.2.3 Operating environment

The operating environment can be, or be influenced by, for example,

- an open, congested or restricted site,
- the topography,
- site conditions, e.g. dust, water, light, contrast,
- weather, or
- sources of interference such as other machines, stronger reflectors or emitters.

A.2.4 Machine functions

These functions can be, for example,

- hazard zones to be covered,
- analysis of machine movement and application at job site,
- available mounting positions,
- anticipated movement speed,
- turning circle,
- articulation effects, or
- stopping distance.

A.3 Selection of HDS and VA

The system should be selected considering the following characteristics:

- visual or sensor detection;
- active or passive response;
- visual or audible warning or both;
- response time;
- detection zone;
- operational integrity;
- mounting security;
- overriding, muting and disablement requirements;
- unwanted alarms;
- maintenance, servicing and cleaning requirements;
- performance checking requirements, e.g. periodic detection zone verification.

Table A.1 — Some advantages and disadvantages of HDS and VA

Technology	Description	Advantages	Disadvantages	Range
Fresnel lens	A thin, flat lens using concentric circular grooves in its surface. The grooves act like prisms to bend and focus light.	Allows driver to see objects below the normal driving position line of sight.	Image can distort near envelope edges; external light can cause lens to be "flooded" with light; external light source needed; interpretation of image and judging distances may be difficult.	Horizontal: > 90°. Vertical: typically 2 m. Depends on mounting position.
Mirror	A reflective surface providing indirect vision.	Low maintenance and simple to use.	Requires good light conditions. Mounting can affect performance. Can be prone to mechanical damage.	Potentially long depending upon optical characteristics.
Discriminating external alarm	Uses a sensor to trigger warning alarm.	Activated when machine movement selected. Warns only when object detected.	Relies on pedestrian in path of machine taking avoiding action. Can be difficult to determine direction noise originating from. Potential for confusion if more than one machine is operating in close proximity.	Variable according to decibel output, frequency, mounting position and environmental characteristics.
Ultrasonic	Presence and distance of object measured by time of flight of reflecting pulses.	Accurate indication of target distance; both LED and audio signals to operator.	Time delay restricts usage to slow vehicles. Performance may be affected by adverse weather. Limited to operating at reverse speeds up to 10 km/h. Multiple sensors required to cover entire back area of machine. Detects any obstacle without discrimination. Limited mounting height above ground.	Horizontal: 6 m max.
Radar				
Fixed frequency Doppler	Microwave radiation is emitted and reflected from a moving object, frequency difference indicates motion.	Low cost; reflects well from most hazards; ignores dirt on surface of radar; not affected by snow, wind, rain, etc. Can be designed to detect speed and direction of object.	Difficulty sensing stationary objects. Distance can only be inferred from strength of reflected signal. Therefore at a given sensitivity the system will respond equally to large objects further away as to smaller objects closer to the sensor. Not fail safe. Can sense objects outside path of vehicle. Can only detect a person who moves.	Range unlimited (but see under "Disadvantages"). Span up to 160° by design.

Table A.1 (continued)

Technology	Description	Advantages	Disadvantages	Range
Switched frequency Doppler	See above, except the transmitted frequency is stepped between two or more frequencies.	Can measure range. Reflects well from most hazards; ignores dirt on surface of radar; not affected by snow, wind, rain, etc. Can be designed to detect speed and direction of object.	Range measured is the weighted average range of all targets. Therefore, small targets close to the sensor may be masked by larger targets further away. Not fail safe. Can sense objects outside path of vehicle.	Range unlimited, but see under "Disadvantages". Span up to 160° by design.
Pulse radar	Presence and distance of object measured by time of flight of reflecting pulses.	Can identify ranges of multiple targets.	Can sense objects outside path of vehicle.	Range may be limited. Span up to 160° by design.
Frequency modulated continuous wave (FMCW)	See above, except the transmitted frequency is swept from low to high and back again.	Can identify the ranges of multiple targets. Can be designed to detect speed and direction of object.	Can sense objects outside path of vehicle.	Unlimited. Span up to 160° by design.
Closed circuit television (CCTV)	Device uses wide-angle lens cameras with a monitor in the cab.	Scratch, dirt and water resistant; works in low light conditions.	Distortion makes distances hard to judge. Direct light into the camera causes visibility problems. Direct sun on monitor blocks the image. Objects in shadows are difficult to distinguish. Mud and dust on camera lens can distort the image. This can be removed by built-in wash/wipe systems.	Horizontal: up to 127°. Vertical: up to 115°.
Infrared				
Passive	Senses changes in infrared emissions from objects	Ideally detects the difference between a person and the background.	Sensitive to dirt, water, vibration. Cannot measure distance. Cannot distinguish a close person from a far hot engine.	May be limited in this application — see under "Disadvantages".
Active	Presence and distance of object measured by time of flight of reflecting pulses.	Unknown.	Unknown.	Unknown.
Contact	The brakes are activated after a switch is triggered by a pivoted bumper.	Simple and relatively inexpensive.	Not suitable for all machines. No prior detection. Not considered safe for pedestrian protection. Suitable only for very slow speed applications.	Determined by dimensions of device.

Table A.1 (continued)

Technology	Description	Advantages	Disadvantages	Range
Electromagnetic (radio frequency) signal transponder	Radio waves interact between the vehicle and "tags" worn by workers or other hazards.	Mutual warnings to both parties; monitors every direction.	Does not monitor anything without a tag. Radiated power is too weak to pass through the human body and to cover all the detection zone. They are directional, like the ultrasonic transponder (see E.4.1). Can detect a person outside the required detection area and requires a judicious choice of the radio frequencies.	Adjustable to 20 m in every direction.
Laser	Software programmable system using a pulsed laser and a revolving mirror.	Detection zone can be precisely configured. Different functions can be given to different zones (e.g. apply brakes, sound horn, etc.).	Can suffer from interference from direct sunlight. Heavy steam or plumes of smoke could act as a barrier. Another laser operating on the same wavelength could also signal an alarm. Lens requires frequent cleaning. Diode has limited (approx. 5 year) life.	Maximum practical range of 8 m and scan angle of 180°; beam thickness of up to 50 mm.
Ultrasonic transponder	Dual ultrasonic waves communicate between "detecting device" installed on the vehicle and "responder" worn by workers.	Can be adjustable for the detection range required. Sends an alarm directly to both the vehicle operator and the worker. Generates visual and audible warning to the operator and audible warning to the workers.	Does not detect anything without a responder.	Maximum detection range is 12 m that can be set in 1 m steps. Detection width is based upon selection of transducer. For example: transducer can be provided as 20°, 30°, 40° and 60° directivity.
Colour recognition CCTV	CCTV image analysed to detect specific colour worn by workers.	Mutual warnings to both parties; monitors within camera's field of view.	Does not monitor anything without a colour tag.	10 m to 15 m width depending upon camera lens angle.

Annex B (normative)

Test procedure for closed-circuit television (CCTV) systems — Additional performance requirements and tests

B.1 Introduction and purpose of tests

The tests are designed to measure the performance of CCTV systems intended for use on earth-moving machinery. Aspects of the performance to be determined are

- a) overall quality of the image presented in terms of TV lines resolved or equivalent, based on the scale on the test body (see B.2) reading that can be resolved,
- b) limit of operational light levels to maintain minimum proposed resolution,
- c) vertical and horizontal fields of vision for the system,
- d) detection distance (see 4.3.1),
- e) masking due to direct exposure to high intensity light, and
- f) time taken for the system to respond fully to rapid changes in light levels.

The tests are not designed to measure aspects of performance due to the camera's height. The performance criteria laid down in these tests assume operating conditions of at least 50 lx average and 20 lx minimum measured illuminance.

B.2 Test body

The Rotakin test body described in EN 50132-7:1996, Annex A, shall be used.

B.3 Test areas

For internal tests: 5 m × 5 m level floor area. For external tests: 30 m × 8 m level area.

B.4 Test environment

The test environment shall be evenly lit, free from shaded areas and reflections in field of view.

B.5 Mounting and set-up

B.5.1 Assembly

The CCTV system shall be assembled according to the manufacturer's instructions.

B.5.2 Positioning and alignment

B.5.2.1 Camera

The camera shall be aligned vertically and horizontally to the test body.

B.5.2.2 Test body

The test body shall be vertical and shall face the camera at the centre of the field of view, and at 90° to the optical axis of the lens.

Unless otherwise stated, the image of the test body shall occupy the entire vertical field of view of the monitor.

B.5.2.3 Monitor

The monitor shall be mounted, positioned and aligned so that it is normal to the observer's face, at a comfortable height, and shall be free from glare and reflections.

B.6 Horizontal test

B.6.1 Light levels

Light levels shall be greater than 50 lx and less than 50 000 lx.

B.6.2 Test procedure

Position the test body away from the camera so that the image occupies 25 % of the vertical height at the centre of the monitor screen. Measure and record the distance from the camera to the test body. Move the test body along an arc to the point where the vertical centre line of the image of the test body is at the edge of vision in the monitor screen. Mark the point.

Similarly, establish and mark the point at the opposite side of the monitor screen. Measure and record the distance between the two marks and calculate by trigonometry the horizontal field of view.

B.7 Vertical test

B.7.1 Light levels

Light levels shall be greater than 50 lx and less than 50 000 lx.

B.7.2 Test procedure

Rotate the camera and monitor through 90°. Position the test body away from the camera so that the image occupies 25 % of the vertical height at the centre of the monitor screen.

Measure and record the distance from the camera to the test body.

Move the test body along an arc to the point where the vertical centre line of the image of the test body is at the edge of vision in the monitor screen. Mark the point. Similarly establish and mark the point at the opposite side of the monitor screen.

Measure and record the distance between the two marks and calculate by trigonometry the vertical field of view.

B.8 Range

B.8.1 Light levels

Light levels shall be greater than 50 lx and less than 50 000 lx.

B.8.2 Test procedure

Position the test body at a point along the optical axis of the camera so that the screen height of the test body image is 7,0 mm. Measure and record the distance from the test body to the camera.

NOTE The effective operating range of the system is based upon a minimum screen height of 7,0 mm. This is approximately 10 % of the vertical screen height, which is normally considered acceptable for visual detection purposes.

B.9 Additional tests

B.9.1 System resolution

B.9.1.1 Light levels

Light levels shall be greater than 20 lx and less than 200 lx.

B.9.1.2 Test procedure

Position the test body away from the camera so that the image occupies 100 % of the vertical height at the centre of the monitor screen.

Determine and record the CCTV system resolution from the scale on the test body reading from set H to set A.

B.9.1.3 Test criteria

A resolution of better than 200 TV lines or equivalent [see B.1, a)] shall be achieved.

B.9.2 Effect of light on resolution

B.9.2.1 Test procedure

Repeat the procedure according to B.9.1.2 in appropriate steps, from the lowest to the highest light levels stated in the manufacturer's specification. Record the light level at which minimum acceptable resolution level is observed.

B.9.2.2 Test criteria

A resolution of better than 200 TV lines or equivalent [see B.1, a)] shall be achieved across the specified light level range or the specified light level range reduced to that equivalent to 200 TV lines.

B.9.3 Edge distortion

B.9.3.1 Light levels

Light levels shall be greater than 50 lx and less than 50 000 lx.

B.9.3.2 Test procedure

Position the test body away from the camera so that the image occupies 25 % of the vertical height at the centre of the monitor screen.

Measure and record the distance from the camera to the test body.

Move the test body along an arc to a point indicated by an observer as being at the edge of vision in the monitor screen.

Measure and record the height of the image of the test body.

B.9.3.3 Test criteria

No reduction in the image dimensions shall be observed at the edge for 25 % of the test body height.

B.9.4 Screen edge resolution

B.9.4.1 Light levels

Light levels shall be greater than 50 lx and less than 50 000 lx.

B.9.4.2 Test procedure

Position the test body at 100 % of the vertical height of the monitor screen.

Move the test body to one side of the screen.

Measure and record the resolution.

Rotate the test body through 180° and repeat the procedure for the opposing screen side edge.

B.9.4.3 Test criteria

A minimum resolution of 200 TV lines or equivalent [see B.1, a)] shall be achieved. If this resolution is not achieved across the entire monitor screen, the field of view shall be specified as the angle at which the resolution is achieved.

B.9.5 High intensity light effect

B.9.5.1 Light levels

Test to be carried out outdoors in direct sunlight.

B.9.5.2 Test procedure

Point the camera straight at the sun to produce a masking on the monitor.

Position the test body close to, and in front of, the camera and move the test body directly away from the camera until the image of the test body is wholly obscured by the masking.

Measure and record the distance from the camera to the test body, and the width of the masking. This measurement shall be taken at the shoulder point of the test body.

B.9.5.3 Test criteria

Unless otherwise specified, the maximum width of the masking shall be no more than 5 % of the viewable screen width.

B.9.6 Recovery from radical change in light levels**B.9.6.1 Light levels**

Place the test body against a brightly lit background, in an elevated position so that it is visible with little or no background objects on the monitor.

B.9.6.2 Test procedure

Place a shutter over the camera and hold for 5 s.

Remove the shutter.

Measure and record the time taken for the silhouette of the test body to be clearly discernible.

B.9.6.3 Test criteria

Unless otherwise specified, the recovery time shall be no more than 1,5 s.

B.10 Functional tests

Verify the operation of any additional features of the system, such as mirror/normal image and day/night setting for the monitor.

NOTE Some systems can be switched for forward or rearward use. In forward use the image on the monitor is usually set to normal image, while for rearward use the image on the monitor is usually set to mirror image. If a two-camera system — one for forward use and the other for rearward use — is to be connected to a single monitor, then automatic switching between mirror and normal image can be required.

B.11 Recording**B.11.1 Information**

The following information about the CCTV system shall be recorded:

- technical specifications for the monitor and camera;
- cable length;
- model number;
- serial number;
- test date(s).

B.11.2 Test values

The test values obtained from tests B.6, B.7, and B.8 shall be recorded, as illustrated in Figures B.1 and B.2.

B.11.3 Actual values

The actual values measured for the tests in B.9 shall be recorded with the corresponding test criteria.

B.11.4 Functional performance

Functional performance from test B.10 shall be recorded as either a positive or negative result for each function.

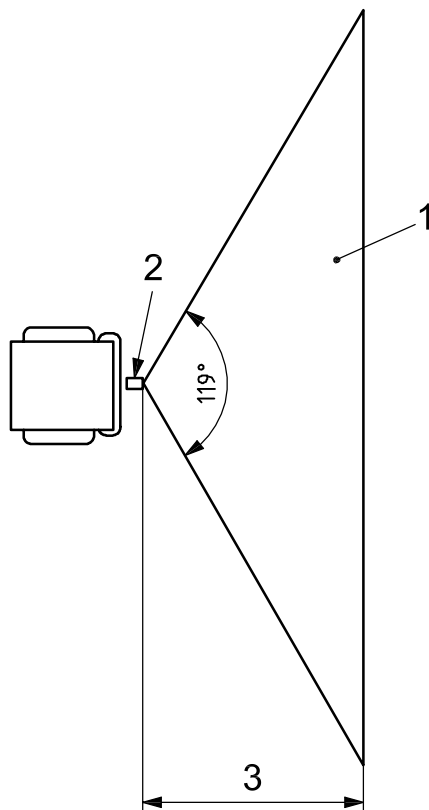

Key

- 1 recorded angle and range
- 2 camera
- 3 range, in metres

Figure B.1 — Horizontal field of view

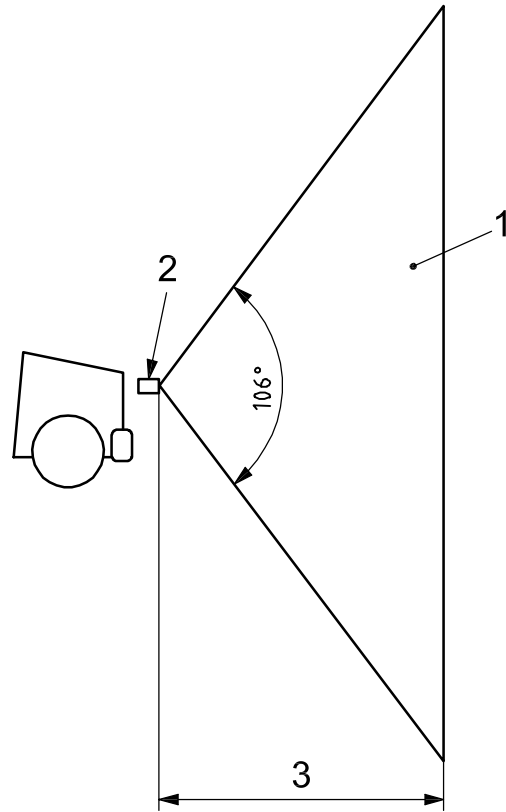

Key

- 1 recorded angle and range
- 2 camera
- 3 range, in metres

Figure B.2 — Vertical field of view

Annex C (normative)

Test procedure for radar sensors

C.1 Introduction

This test procedure describes the method for determining the detection zone for radar systems used to detect obstacles near earth-moving machinery. The procedure is designed to identify the geometry of the three-dimensional zone within which a person will be reliably detected.

This procedure does not evaluate the position of that zone with respect to the machine on which the radar sensor is to be fitted. Practical considerations regarding the application of this zone to earth-moving machines are given in C.11.

C.2 Test body

The test body shall be that part of a human body which will protrude into the detection zone. In some situations around the edge of the detection zone, the first part of the body to protrude into the zone will be the head. This test procedure will therefore use the detection of the head alone as the point of measurement for the edges of the detection zone.

NOTE The consistency of results with real people of varying sizes has been found to be greater than those with artificial substitute objects. The test procedure has therefore been designed to accommodate the use of a real person.

C.3 Test area

The test area shall be an open space on flat terrain with a dry sand and/or gravel base. No rocks, foliage, or debris larger than 8 cm in diameter shall be in the test area. No large objects such as buildings or heaps shall be within approximately 50 m directly in front of the radar system. No large objects shall be within 25 m of either side of the radar system. All personnel, except whoever is conducting the test, shall remain in an area where they will not be detected by the radar system.

Mark out a rectangular grid with lines at 1 m intervals over an area equal to the expected detection zone.

C.4 Test environment

The test environment shall be in accordance with 4.1.3.

C.5 Radar mounting locations

The radar shall be mounted on a static stand in the manner described in the test procedure. No part of the stand shall be within the detection zone of the radar.

The radar mount shall have a facility to tilt the radar in the vertical plane through the angle required by the test procedure and a means of measuring the angle of tilt.

C.6 Test procedure

C.6.1 General

Radar sensors emit and receive within a conical beam that can have a circular or elliptical cross-section. By measuring the horizontal and vertical limits of the detection zone, the full geometry of the zone can be constructed as shown in Figure C.1.

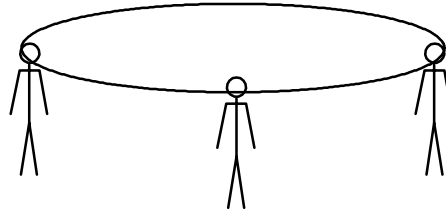

Figure C.1 — Measuring full geometry of detection zone

C.6.2 Measuring horizontal limits

Position the radar as normally oriented on the machine but with the radar beam extending horizontally and the centre of the radar beam at the height of the nose on the head of the test person.

Position the warning device where it can be heard by the test person and the person conducting the test.

Move the test person 0,5 m away from the radar on the centre line of the anticipated detection zone. If the warning device indicates detection, move the test person sideways in each direction until detection does not occur. Record the last position where detection occurs on each side. Record any position between these points where detection does not occur.

Move the test person a further 0,5 m away from the radar and repeat the above procedure.

Repeat the procedure at 1 m intervals away from the radar until detection does not occur.

Record the horizontal limits of the detection zone. Record any areas within this zone where detection did not occur.

C.6.3 Measuring vertical limits

Position the test person 0,5 m away from the radar on the centre line of the horizontal detection zone. If detection occurs, tilt the radar upwards until detection does not occur and record the maximum angle of upward tilt where detection does occur.

Repeat this test at 1 m from the radar and at further intervals of 1 m until the end of the horizontal detection zone.

Invert the radar in the mounting so that the normal top of the detection zone is at the bottom. Check that the centre of the beam is again level with the nose of the test person.

Repeat the above test to record the angle at which detection occurs at each distance from the radar.

C.7 Adaptation of test procedure for different types of radar

Certain types of radar sensor may include relative movement between radar and test object in the detection strategy. If this function is optional, it should be switched off for the purposes of this test. If it cannot be switched off then the test person may mimic the movement required.

Record whichever of the following applies:

- a) no movement required for detection strategy;
- b) movement requirement switched off;
- c) movement is always required.

If movement is always required, record the type of movement required, the speed and/or the distance.

C.8 Adaptation of test for radar sensors with programmable detection zones

Where a radar sensor can be programmed to create a variety of detection zone shapes and sizes, the tests specified in C.6.2 and C.6.3 shall be used to confirm the maximum dimensions of the detection zone that can be programmed as specified by the manufacturer.

C.9 Recording maximum detection points

The maximum detection points for the horizontal plane shall be shown on a diagram with a 1 m grid as illustrated by the example shown in Figure C.2.

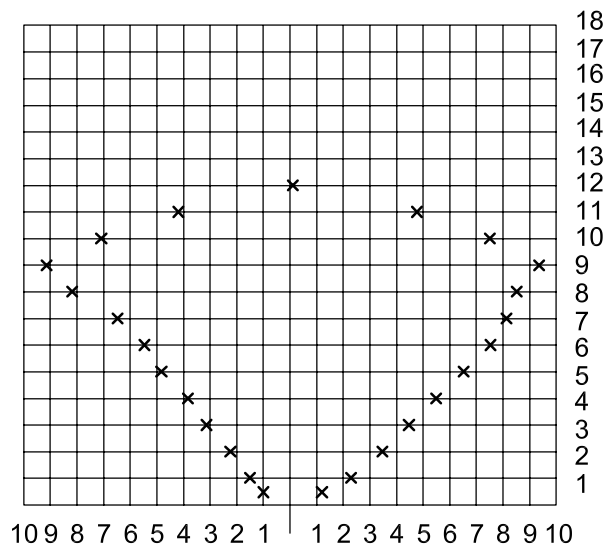

Figure C.2 — Maximum detection points for horizontal plane

The maximum detection points for the vertical plane shall be shown on a diagram with arcs at 1 m spacing, as illustrated in the example shown in Figure C.3.

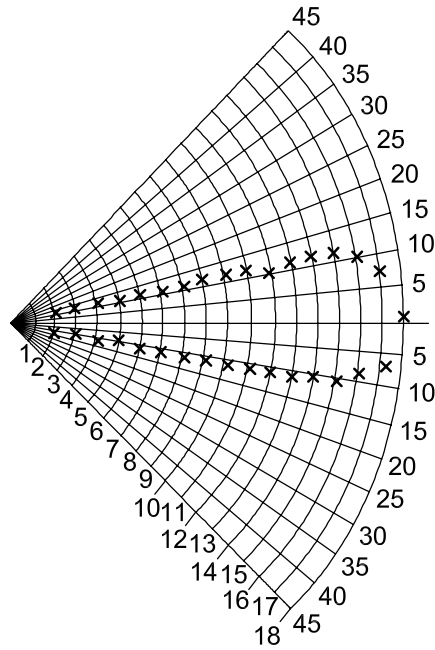

Figure C.3 — Maximum detection points for vertical plane

C.10 Additional testing

C.10.1 Alarms from large objects outside the detection zone

Large structures, such as other machines, could be detected at wider angles and greater distances than a person and can generate unwanted alarms. The test according to C.6.2 shall be repeated using a trihedral metallic reflector as the test object, as shown in Figure C.4. Hold the test object at the height of the horizontal axis of the radar beam with the concave surface pointing toward the radar. Record the detection zone in the same manner as for a person.

NOTE As it has proven difficult to obtain consistent results with any test object designed to simulate a large structure, this test needs to be regarded as an indication only of the detection zone for large structures.

Dimensions in millimetres

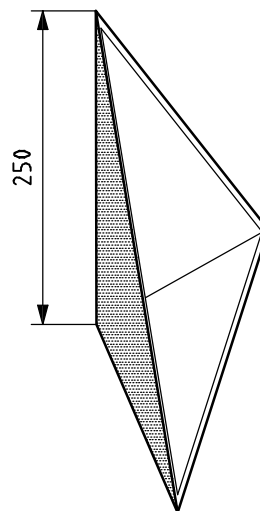

Figure C.4 — Test body simulating large structure

C.10.2 Detection suppressed by large objects in background

Certain methods of radar range measurement can cause large objects in the background to dominate the range measurement and mask the presence of smaller objects closer to the radar. The manufacturer shall state whether such methods are used and explain any additional strategies used to minimize this effect.

A standard test of this effect can give misleading results as it might not take into account any additional strategies to minimize this effect. Where such methods are used, the manufacturer shall describe a test using the test object in Figure C.4 to demonstrate the extent to which this effect has been reduced.

C.11 Practical considerations for mounting radars on machines

The manufacturer shall include in the instruction manual practical considerations for mounting radars on machines, with regard to the following.

The above tests describe the three-dimensional zone within which detection will occur if a sufficiently large part of a person penetrates this zone. The tests are conducted with a person, but other objects, including the ground, may also be detected. The detection zone should therefore be positioned to intercept a person but to avoid intercepting the ground, as this can cause unwanted alarms.

Consideration shall be given to the fact that the vertical limits measured apply only on the horizontal centre line. The depth of the conical zone tends to zero at the horizontal limits, as shown in Figure C.2.

Ideally, the radar should be mounted at a height less than 1,5 m. If this is impractical, then the detection zone close to the radar may be above the height where a man will be detected. If the radar beam is tilted down to improve detection close to the radar, unwanted alarms may occur from the ground.

This should be checked on ground typical of the intended working environment as the smooth, dry ground of a typical test site will cause less reflection back towards the radar than wet, rutted mud. Some ground, notably sand, may not cause unwanted alarms even when the radar is tilted towards it.

The radar should normally be mounted so that no part of the machine intercepts the detection zone in order to avoid unwanted alarms. However, certain radars can include detection strategies that will ignore objects which have no movement relative to the radar. The manufacturer should indicate where this applies.

Annex D (normative)

Test procedure for ultrasonic detection systems

D.1 Introduction and purpose of tests

The tests are designed to measure the performance of ultrasonic detection systems intended for use on earth-moving machinery.

Aspects of the performance to be determined are the following:

- overall performance criteria of the system;
- the performance criteria and limits of detection zone;
- the criteria for location and fixing of the components;
- the operational system's reliability;
- deactivation of the system;
- the detection time;
- physical environment conditions (vibration, shock, temperature, humidity).

The dimensions shown in Figures D.1 to D.3 are for illustrative purposes only and are based upon an example where a 6,0 m range is required. The specific range required depends upon the application of the machine.

This annex describes requirements and tests of ultrasonic detection systems for earth-moving machinery with an operational ³⁾ reverse speed of up to 10 km/h.

NOTE Performance requirements and tests of ultrasonic detection systems for slow-moving earth-moving machines (operational reverse speed of up to 3,0 km/h) are determined according to ISO/TR 9953.

D.2 Test body

The geometry of the monitoring area is tested with the following test objects.

D.2.1 Test body H for horizontal testing

Test body H for the horizontal test consists of a tube 75 mm in diameter and of length 1 700 mm, of grey colour and of hard plastic or metallic construction.

D.2.2 Test body V for vertical testing

Test body V for the vertical test consists of a tube 75 mm in diameter and of length 300 mm, of grey colour and of hard plastic or metallic construction.

3) Typical working mode of wheel loaders, dumpers etc., when reversing.

D.3 Test area

D.3.1 Detection zone shape

The horizontal and vertical detection zone is defined by the dimensions shown in Figure D.1 and Table D.1.

D.3.2 Test surface

The test surface shall be a levelled and firm plane of at least 5,0 m width and 8,0 m length.

D.4 Test environment

The conditions given in 4.1.3 apply with the following addition:

- wind velocity $\leq 5,4$ m/s.

D.5 Mounting and set-up

D.5.1 Location and fixing of sensor(s) on machine

The sensor(s) shall be so located and arranged on the machine that the detection zone as specified in D.3.1 is covered.

The number of sensors to be used depends on the machine width ⁴⁾ and the beam shapes of the sensors.

The device shall be permanently affixed to the machine.

D.5.2 Location and fixing of evaluation device

The evaluation device shall be located inside the operator's station or at an adequate location on the machine so as to prevent environmental and high vibration or shock loads (see 4.8 for physical environment performance criteria required for the device).

D.5.3 Location and fixing of warning (audible and visual) device

The device shall be located at the operator's station and shall meet the requirements of 4.3.2.

4) Experience has proven that with the current type of ultrasonic sensors with a reach of up to 6,0 m, the following arrangement is required: location of the first sensor, left and right: ≤ 500 mm from the machine outside boundary. The number of sensors in relation to the machine width is as follows:

Machine width mm	Number of sensors
$\leq 2\,500$	4
$\leq 3\,000$	5
$\leq 3\,500$	6

The sensors should be symmetrically arranged.

D.5.4 Actuation of system

The system shall be provided with a stand-by mode. A separate actuation of the warning device shall be provided that is activated in the reverse operating mode.

The system shall meet the requirements specified in 4.5.

D.5.5 Detection time

The detection time shall be in accordance with 4.5, together with the following: this time shall be calculated as an arithmetic mean of at least 50 measurements in the course of which a test body (as specified in D.2) is moved at a speed of 1 m/s from outside the detection zone to the 3,0 m grid position, i.e. the trigger point for the time measurement.

D.5.6 Operational reliability

D.5.6.1 Systems check

The systems check shall control the function of the whole system and be confirmed by a short audible signal of less than or equal to 10 ms. The systems check shall be automatic after activation of the system. The system shall meet the requirements of 4.5.

D.5.6.2 Malfunction warning

In case of a malfunction, a warning shall be given to the operator.

D.5.6.3 Operational integrity

The system shall meet the requirements of 4.6.

D.5.7 Tests

D.5.7.1 Adjustment of system

Before starting the test procedure, the system shall be adjusted as follows:

D.5.7.1.1 Adjustment of warning ranges

If the system has two or three warning ranges, these ranges shall be adjusted at the evaluation unit following the system manufacturer's instruction.

EXAMPLE A system with a 6,0 m maximum range is adjusted to the 2,0 m (emergency warning), 4,0 m (pre-warning) and 6,0 m (warning) ranges.

D.5.7.1.2 Sensor adjustment

D.5.7.1.2.1 Height adjustment of the monitoring area

Use the vertical test body, V, and place it at the sensor centre line at maximum reach (as adjusted — see D.5.7.1.1 — less 100 mm) and move the test body from the ground up to the position where test body V is detected (visual and acoustic signal). Note the height (centre line of test body V) above the ground and adjust the sensor so that this height is 800 mm (–100 mm).

D.5.7.1.2.2 Horizontal adjustment

Use the horizontal test body, H, and place it at half the distance of the maximum reach (as adjusted — see D.5.7.1.1), on both the left and right 100 mm outside of the detection zone as defined in D.3.1.

Adjust the two outer sensors left and right so that test body H is detected.

The other sensors shall be adjusted perpendicularly to the machine longitudinal axis.

D.5.7.1.3 Verification of detection warning ranges

If the system has two or three warning ranges, verify the correct adjustment of the range by placing test body H 100 mm before and after the adjusted range (see D 5.7.1.1 and Figure D.2).

For example, for a 2 m warning range:

- at 1,9 m distance from the sensor: emergency warning.
- At 2,1 m distance from the sensor: pre-warning.

D.5.7.2 Static test of detection zone

The test method shall be performed on a system that is fitted to the machine.

If the test is performed without a machine, then the sensors shall be arranged 1,2 m above the test surface as specified in D.3.2 and located in accordance with D.5.1.

D.5.7.2.1 Horizontal test

Position test body H statically, with the longitudinal axis in the detection zone, standing perpendicular to the ground, so that its longitudinal axis is in the grid position of each measuring point shown in Figure D.2.

D.5.7.2.2 Vertical test

Position test body V statically, and horizontally in the detection zone, so that its three-dimensional centre is situated in the specific grid position of each measuring point as shown in Figure D.3.

D.5.7.3 Evaluation of the test result

Test bodies H and V shall be detected statically in all grid positions. Detection shall take place unambiguously with an uninterrupted sequence of the signal appropriate to the measuring distance. If the test body is not detected in one position, displace the position to the left and right (test body H) or up and down (test body V) by the width (diameter) of the test body.

The test body shall be detected perfectly in both positions.

D.6 Test report

The test report shall include the following information.

a) System identification

- 1) Manufacturer:
- 2) Model:

- 3) Identification
 - i) Evaluation device (part number and serial number):
 - ii) Warning device (part number and serial number):
 - iii) Centre(s) (part number and serial number):

b) Test conditions

- 1) Test surface:
- 2) Test environment
 - i) Wind velocity (m/s):
 - ii) Temperature (°C):
 - iii) Relative humidity (%):
- 3) Mounting and set-up
 - i) Detection zone:
 - I) width: mm;
 - II) length mm.
 - ii) Sensor fixing:
 - I) machine:
 - II) test bar:
- 4) Sensor arrangement
 - i) distance from the outside boundary: mm;
 - ii) distance between sensors: mm;
 - iii) adjustment of warning ranges:
 - iv) emergency warning: m;
 - v) pre-warning: m;
 - vi) warning: m.
- 5) System performance
 - i) System activation/check (see D.5.6.1):
 - ii) Actuation time (see D.5.4):
 - iii) Detection time (see D.5.5):
 - iv) Malfunction control (see D.5.6.2):
 - v) Operational integrity (see D.5.6.3):
 - vi) Physical environment (see D.4):

c) Test result

- 1) Horizontal test (see D.5.7.2.1):
- 2) Vertical test (see D.5.7.2.2):
- 3) Warning ranges (see D.5.7.1.3):

Dimensions in millimetres

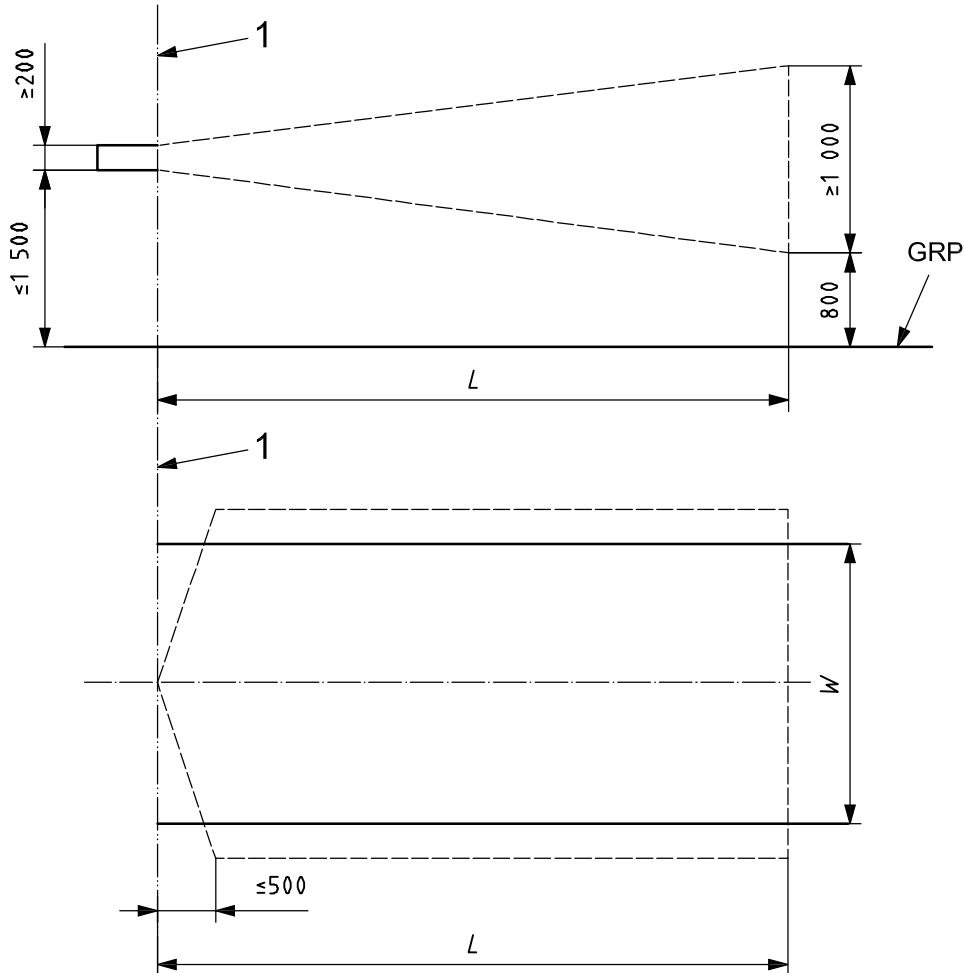

Key

- 1 reference line (front of the sensor)
- L basic length
- W basic width, relating to the required detection zone width
- GRP ground reference plane

Figure D.1 — Detection zone shape

Table D.1 — Detection zone size

Max. operational reverse speed	L m	W m
a	$\geq 6,0$	As specified by the system manufacturer

^a Usual rearward operating speed: 0–10 km/h in a work cycle.

Dimensions in millimetres

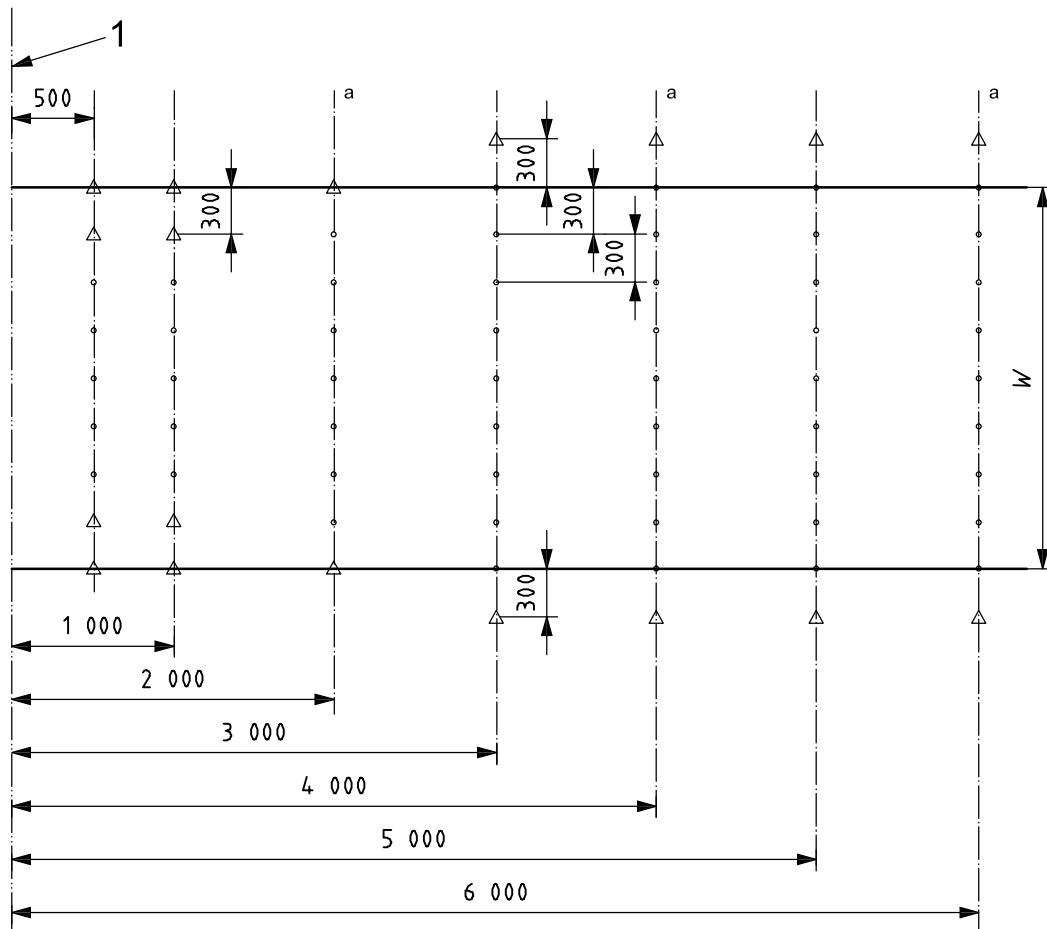

Key

- 1 reference line (front of the sensor)
- measuring point with test body H
- Δ optional measuring point
- W width
- a See D. 5.7.1.3.

Figure D.2 — Horizontal detection zone and test grid for static test

Annex E (normative)

Test procedure for ultrasonic transponder systems

E.1 Introduction and purpose

An ultrasonic transponder system is a system by means of which a worker is detected by dual ultrasonic wave communication between a *detecting device* installed on the machine and a *responder* worn by the worker.

This annex provides a test method for verifying the detection zone necessary to prevent accidental contact between the machine and the worker and confirming that the worker who enters the detection zone is detected without fail.

E.2 Test body

The test body shall be a responder worn by a dummy which represents the 50th percentile human body (see Figure E.1). Responders shall be fitted to a helmet, vest or any other outfit a construction worker can wear.

E.3 Test condition

E.3.1 Test area

The test area shall be a flat surface with a minimum width of 20 m and a minimum length of 20 m.

E.3.2 Test environment

This shall be as follows:

- a) temperature in accordance with 4.1.3;
- b) relative humidity in accordance with 4.1.3;
- c) wind velocity of 10 m/s or less.

E.3.3 Mounting of transducer

E.3.3.1 Height and angle

The horizontally set responder position and vertically offset responder position are shown in Figure E.1.

E.3.3.1.1 Horizontally set position

The transducer and responder shall be set at 1,5 m above the ground. The transducer shall be rotated at the position. The detectable rotating angle, clockwise and anticlockwise (counter-clockwise), shall be measured.

E.3.3.1.2 Vertically offset position

The transducer shall be set at 2,5 m above the ground. The responder shall be set at 1,0 m above the ground and at an angle approximately 20° lower in respect to the transducer. The detectable rotating angle, clockwise and anticlockwise (counter-clockwise), shall be measured.

E.3.3.1.3 The distance between the transducer and the responder

The distance, R , between the transducer and the responder shall be set to 0,5 m, 1,0 m, 2,5 m, 5 m, 7,5 m and 10 m.

E.3.3.1.4 Measuring horizontal and vertical patterns

Measurement of the horizontal pattern should be carried out with the transducer positioned as shown in Figure E.2 a).

Measurement of the vertical pattern should be carried out with the transducer positioned as shown in Figure E.2 b).

E.3.4 Checking the detection

Whether or not the transducer detects the responder in the measuring range shall be validated by the visual and/or audible signal integrated in this system.

E.3.5 Criteria

The detection range obtained shall be expressed as shown in

- Figure E.3 for (e.g. 60°) oval type transducers, or
- Figure E.4 for (e.g. 30° × 60°) ellipse type transducers.

E.3.5.1 Detection zone distance

The difference between the maximum distance set at the transducer and the maximum distance at which the responder actually responds shall be ± 10 % or less at the horizontally set position.

E.3.5.2 Detection zone width

The difference between the nominal width set at the transducer and the width where the responder first responds shall be +20 % or less, and –10 % or more, at the horizontally set position.

The difference between the nominal width set at the transducer and the width where the responder first responds shall be ± 20 % or less at the vertically offset position.

Dimensions in millimetres

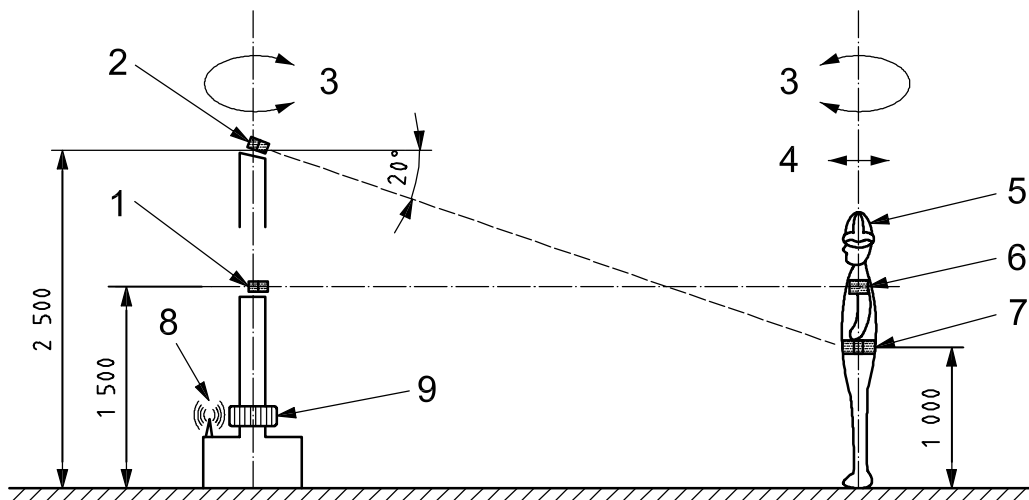

a) Side view

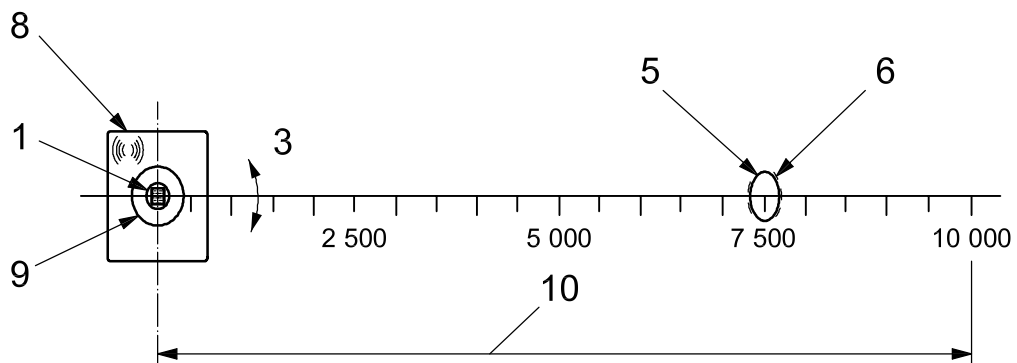

b) Top view

Key

- | | |
|-------------------------|-------------------------|
| 1 first transducer | 6 first responder |
| 2 second transducer | 7 second responder |
| 3 direction of rotation | 8 alarm indication unit |
| 4 direction of movement | 9 rotation pedestal |
| 5 dummy | 10 detection area |

Figure E.1 — Detection area measurement

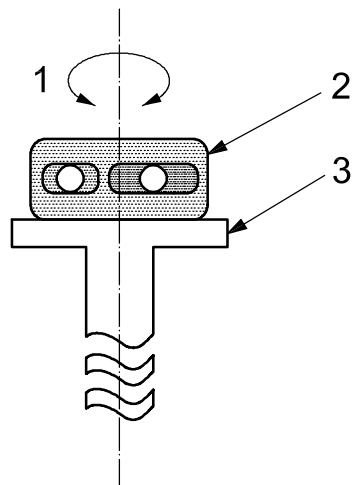

a) Horizontal pattern

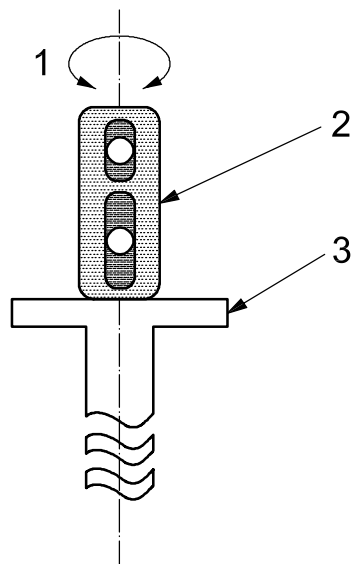

b) Vertical pattern

Key

- 1 direction of rotation
- 2 transducer
- 3 rotation pedestal

Figure E.2 — Horizontal and vertical pattern measurement

.....

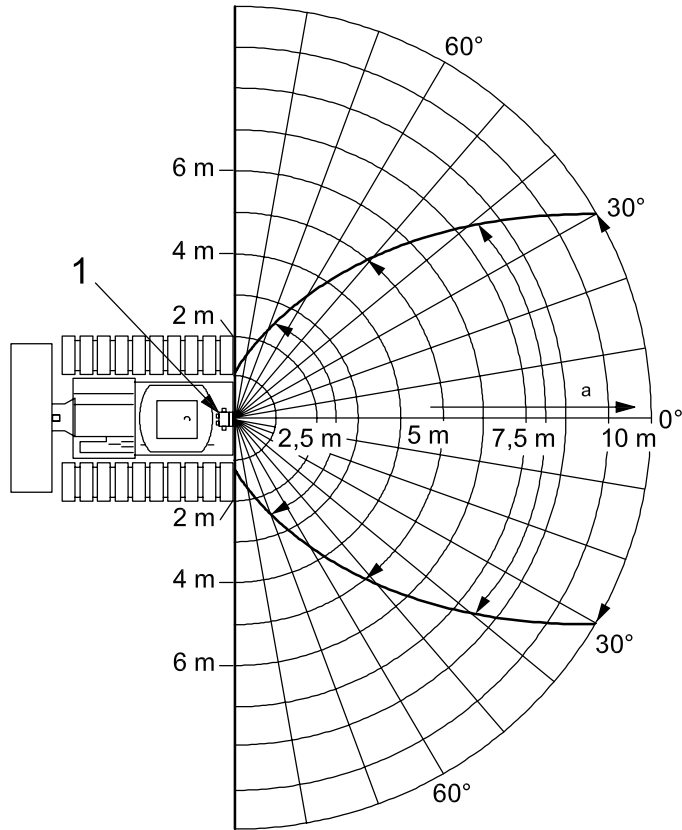

Detection range vs. angle

Range (m)	0,5	1,0	2,5	5,0	7,5	10,0
Angle (degrees)	180	180	130	100	75	60

a) Horizontal pattern

Figure E.3 (continued)

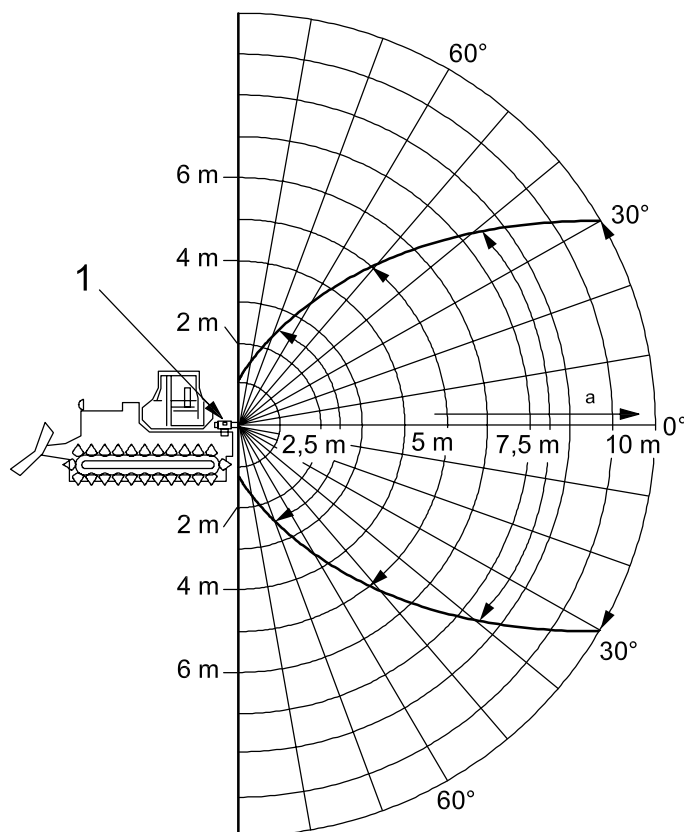

Detection range vs. angle

Range (m)	0,5	1,0	2,5	5,0	7,5	10,0
Angle (degrees)	180	180	130	100	75	60

b) Vertical pattern

Key

- 1 transducer
- a Detection range.

Figure E.3 — Detection area (60° oval type transducer)

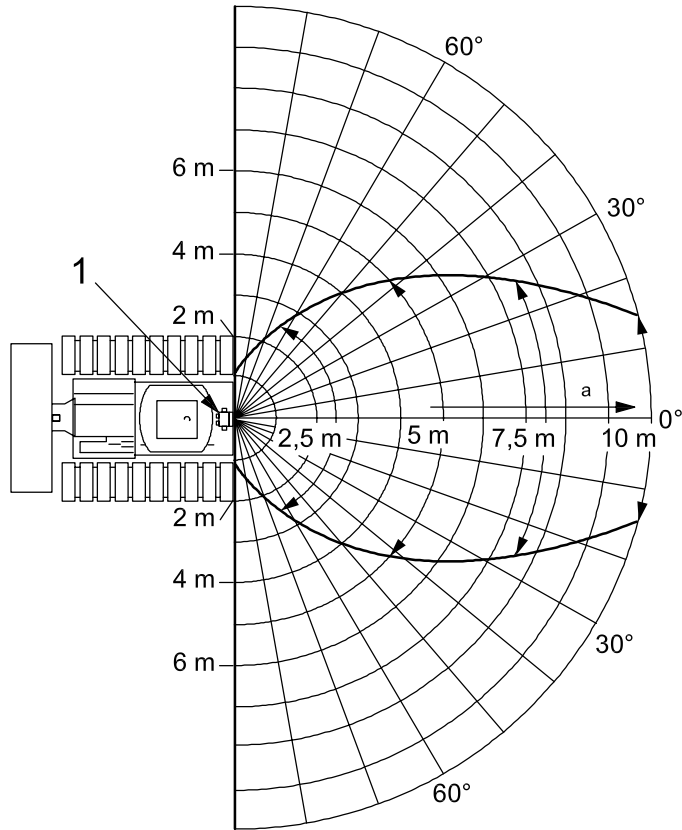

Detection range vs. angle

Range (m)	0,5	1,0	2,5	5,0	7,5	10,0
Angle (degrees)	180	180	120	80	50	30

a) Horizontal pattern

Figure E.4 (continued)

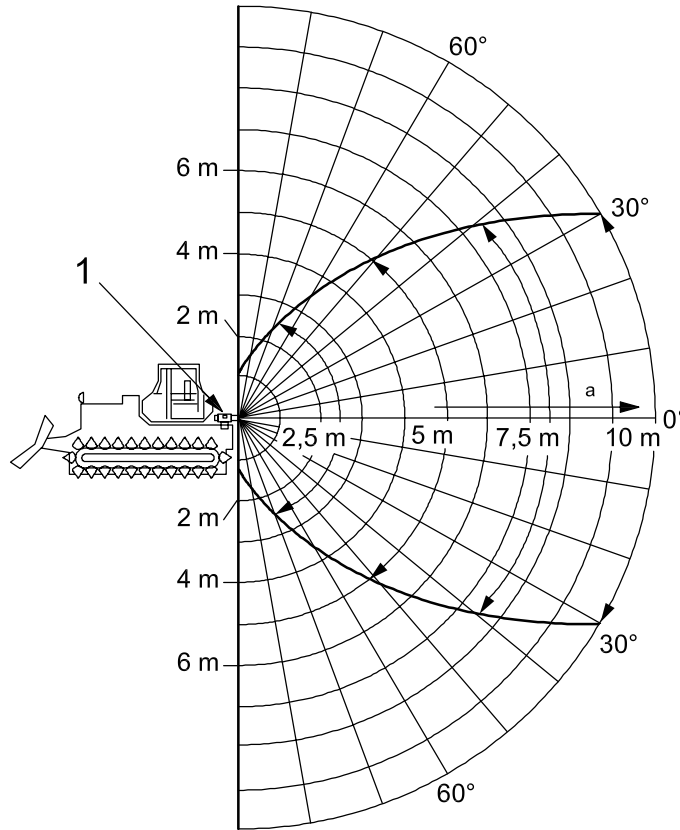

Detection range vs. angle

Range (m)	0,5	1,0	2,5	5,0	7,5	10,0
Angle (degrees)	180	180	130	100	75	60

b) Vertical pattern

Key

- a Detection range.
- 1 transducer

Figure E.4 — Detection area (30° x 60° ellipse type transducer)

E.4 Additional test

E.4.1 Directivity of responder

Since installed numbers and positions of the sensors at a helmet or vest are limited, sensing ability differs at the postures of the test body. In order to see the difference, directional sensitivity shall be checked.

E.4.1.1 Test method

With a horizontally set position, the responder shall be set at 5 m from the transducer.

Rotate the responder from 0° to 360° and check whether a non-responding area of angle exists.

E.4.1.2 Criteria

There shall be no non-responding areas of angle.

E.4.2 Audible alarm

To ensure that the alarm is loud enough for the operator and the workers, an alarm volume test shall be conducted.

E.4.2.1 Test method of alarm at operator cab and criteria

The sound pressure level shall be measured at the operator's ear position. The microphone position shall be positioned according to ISO 6394. The sound pressure level of the alarm with low idling engine noise shall be equal to or shall exceed the sound pressure level of the engine at high idling.

E.4.2.2 The alarm at the responder

Effort shall be paid to provide sufficient sound pressure for the workers. For example, the alarm shall be fitted near an ear so that a worker can hear the alarm.

E.4.3 Environmental durability

Environmental durability shall follow the requirements of the main standard unless specified.

E.5 Test report

The test report shall include the following information.

- a) Manufacturer/model.
- b) Test body.
- c) Test conditions
 - 1) Test area.
 - 2) Test environment:
 - i) temperature;
 - ii) relative humidity;
 - iii) wind velocity.

E.6 Test results

E.6.1 Detection zone shape

The detection zone shape should be recorded as a diagram or drawing of the measured zone, providing three-dimensional information (see Figures E.3 and E.4).

E.6.2 Additional tests

E.6.2.1 Directivity of responder

Verify and record that there is no position at which the test body does not respond.

E.6.2.2 Audible alarm

Record the sound pressure level at the operator's ear when

- the engine is running at high idling, and
- the engine is running at low idling and the alarm sounds.

E.6.2.3 Environmental durability

With reference to 4.8, record that no malfunction was observed for

- the temperature test,
- the humidity test, or
- the shock test.

Annex F (informative)

Test procedure for electromagnetic (EM) signal transceiver systems

F.1 Introduction and purpose

An EM signal transceiver system (including two-way radio) is a system by means of which a worker or other obstacle is detected by communication between a machine-mounted *transceiver* and an *electronic tag* worn by workers or mounted on other obstacles via an electromagnetic signal.

This annex provides a test method for determining the detection zone for EM signal transceiver systems used to detect workers and other obstacles that are outfitted with tags near earth-moving machinery. The procedure identifies the geometry of a two-dimensional zone within which a tag is detected. This procedure does not consider the changes that could occur in the detection zone from interference or other effects when the transceiver is mounted on the machinery. See F.10 for aspects that should be considered when installing these systems on actual machinery.

Because there are many variations of this technology, it will be helpful to distinguish between the main types:

- Type 1: a transmitter and antenna mounted on the machinery radiates an electromagnetic field. The tag detects this field and transmits a signal back to either a separate communications antenna on the machinery or the same antenna used to generate the detection signal. If the tag is within a specified detection range, then an alarm is generated on the machinery to warn the operator. Some systems also generate an alarm at the tag.
- Type 2: the tag radiates an electromagnetic field around the worker or object on which it is mounted. A receiver and antenna mounted on the machinery detects the signal from the tag and generates an alarm for the operator if the tag is within a certain range. An optional and separate signal may be transmitted back to the tag if an alarm is generated at the tag.

F.2 Test body

The test body shall be a stand made from wood (or other material that will not interfere with EM signals) that will allow the mounting of the tag in at least three different orientations at a height of 1 m from the ground, with no part of the stand protruding above 1 m. See Figure F.1.

Dimensions in millimetres

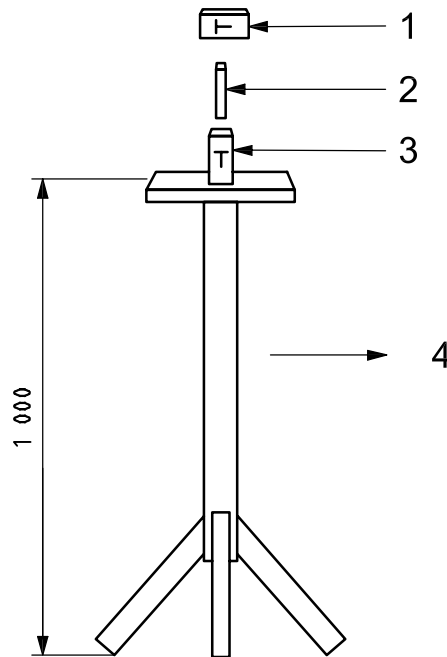

Key

- 1 orientation 3 — lying on side
- 2 orientation 2 — rotated 90°
- 3 orientation 1 — normal
- 4 direction to machine-mounted antenna

Figure F.1 — Test body showing three tag orientations

F.3 Test area

The test area shall be outdoors in an open area with no obstructions that could cause EM signal interference — buildings, vehicles, or other objects — within a 60 m radius from the centre. Mark out a polar grid with radial lines marked every 10° and concentric circles marked every metre. The total radius of the grid should be as large as the expected detection range of the system. See Figure F.2.

Values in degrees

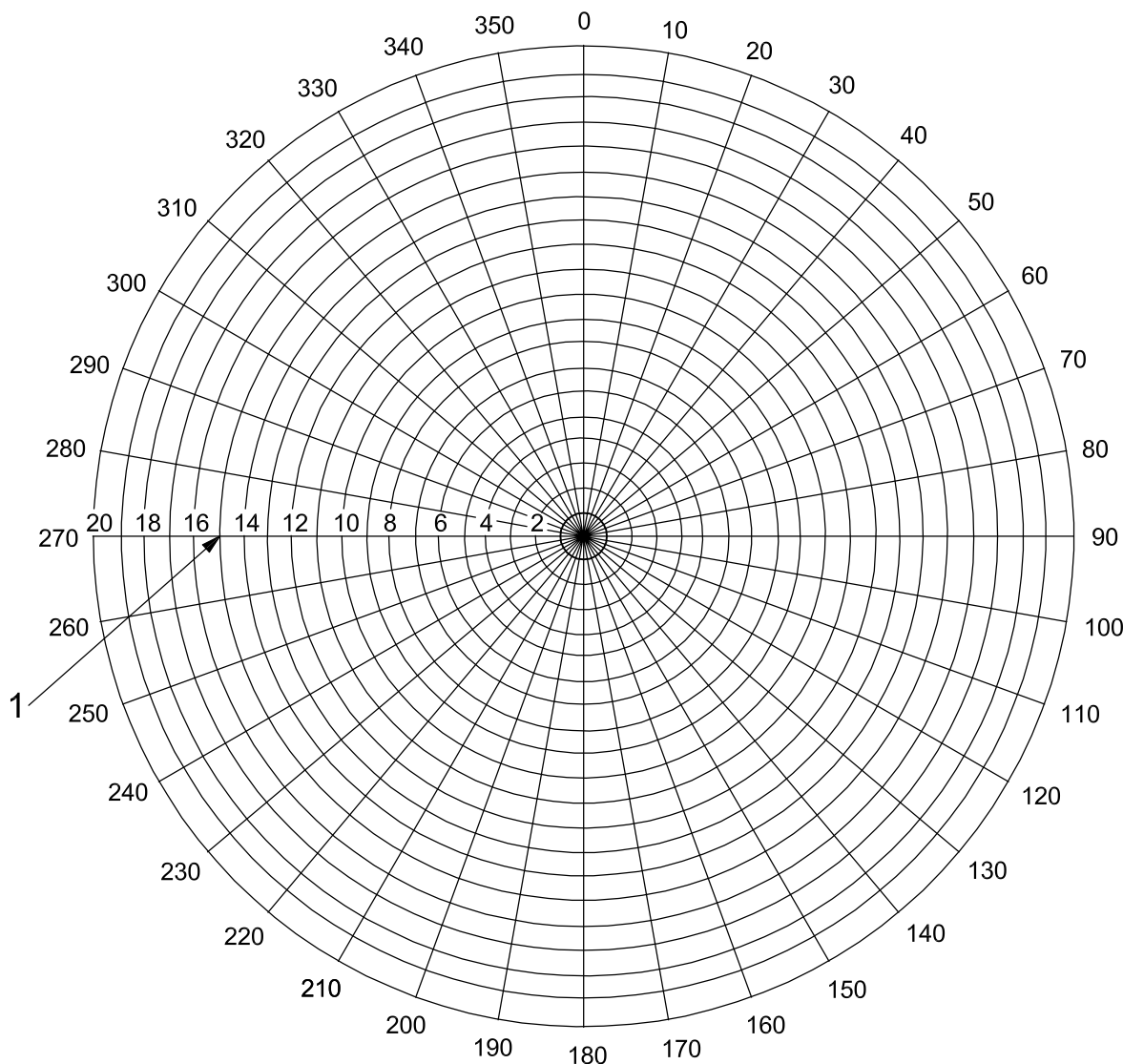

Key

1 distance (in metres) from test body

Figure F.2 — Example grid for test area and plotting paper

F.4 Test environment

The test environment shall be in accordance with 4.1.3.

F.5 Mounting of components meant for machinery

F.5.1 Type 1 system

The components that transmit the detection area signal for the system, i.e. those components normally mounted on the earth-moving machinery, shall be placed in the centre of the test area. The transmitting antenna shall be mounted on a wooden stand (or stand made of another material that will not interfere with EM signals) at a height of 2 m in the same orientation that it would normally be on the machinery; it shall remain stationary. If a separate antenna is used to communicate with the tags, it shall be mounted at a height

of 1 m, directly below the transmitting antenna. The alarm portion of the system shall be situated so that it is easily seen and heard during the tests. See Figure F.3 for an example.

F.5.2 Type 2 system

The components that receive the detection signals from the tags, i.e. those components normally mounted on the earth-moving machinery, shall be placed in the centre of the test area. The receiver antenna shall be mounted on a stand at a height of 2 m in the same orientation that it would normally be on the machinery and it shall remain stationary. If a separate antenna is used to communicate with the tags, it shall be mounted at a height of 1 m directly below the receiving antenna. The alarm portion of the system shall be situated so that it is easily seen and heard during the tests.

Dimensions in millimetres

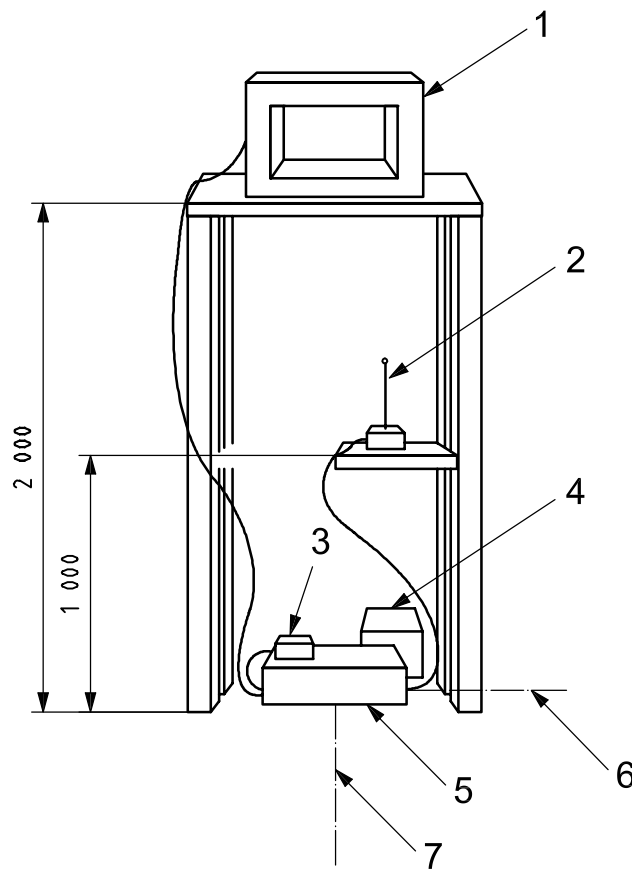

Key

- | | |
|---|-----------------------|
| 1 transmitter or receiver normally mounted on machine | 5 control electronics |
| 2 optional tag communications antenna | 6 270° radial line |
| 3 alarm display | 7 0° radial line |
| 4 power source | |

Figure F.3 — Example of machine component test stand

F.6 Tag mounting

The tag, or component normally worn on the worker or mounted on other obstacles, shall be placed on the test body platform in an orientation expected in working situations. For example, a tag worn on the belt shall be placed on the stand in an upright position similar to the orientation that it would have on the belt of a person facing the components on the machinery (see orientation 1 in Figure F.1). Tags inside a hard hat shall

remain in the hard hat and the hat should be placed on the test body platform in an orientation similar to the one it would have on a person standing upright and facing the components on the machinery.

Besides the above tag orientation, two additional orientations shall be tested with the tag in orthogonal positions to simulate, firstly, a person turned 90° in relation to the first test, and secondly, a person bent over at the waist or lying down facing the machinery. See Figure F.1.

F.7 Test procedure

F.7.1 System settings

If the range of the system is adjustable, i.e. the range over which a tag is detected can be adjusted according to equipment size or speed, then two sets of tests as described in F.7.2 shall be conducted — one with the range set at minimum and the other with the range set at the manufacturer's recommended maximum.

F.7.2 Measuring detection zone

With the machine components at the centre of the test area according to F.3, place the test body and tag on the 1 m radius circle at the 0° radial line. Record whether or not detection occurs. Rotate the tag to the second and third positions as described in F.6, recording detection for each case. The person conducting the test should step aside while detection is noted to ensure they are not causing interference.

Move the test body away from the centre to the next circle along the 0° radial line and repeat the steps described above. Continue along the radial line until detection does not occur for any tag orientation.

Move to the next radial line and repeat the tests. The test body and tag shall be oriented to face the machine components as described in F.6 (the test body will need to rotate to compensate for movement around the circle). Continue until detection has been recorded for all radial lines and distances from the centre.

F.8 Recording detection zones

Each test point specified in F.7.2 shall be recorded on a polar grid as shown in Figure F.4 in order to indicate the dimensions and shape of the detection zone. Reliable detection should be noted for those points where all three tag orientations were immediately detected by the system. Sporadic detection should be noted for those points where only one or two tag orientations were detected. Furthermore, tag detection shall be considered sporadic if any tag orientation resulted in inconsistent detection at that point. The detection area shall be outlined to indicate the overall shape of the reliable detection zone with sporadic areas identified.

Values in degrees

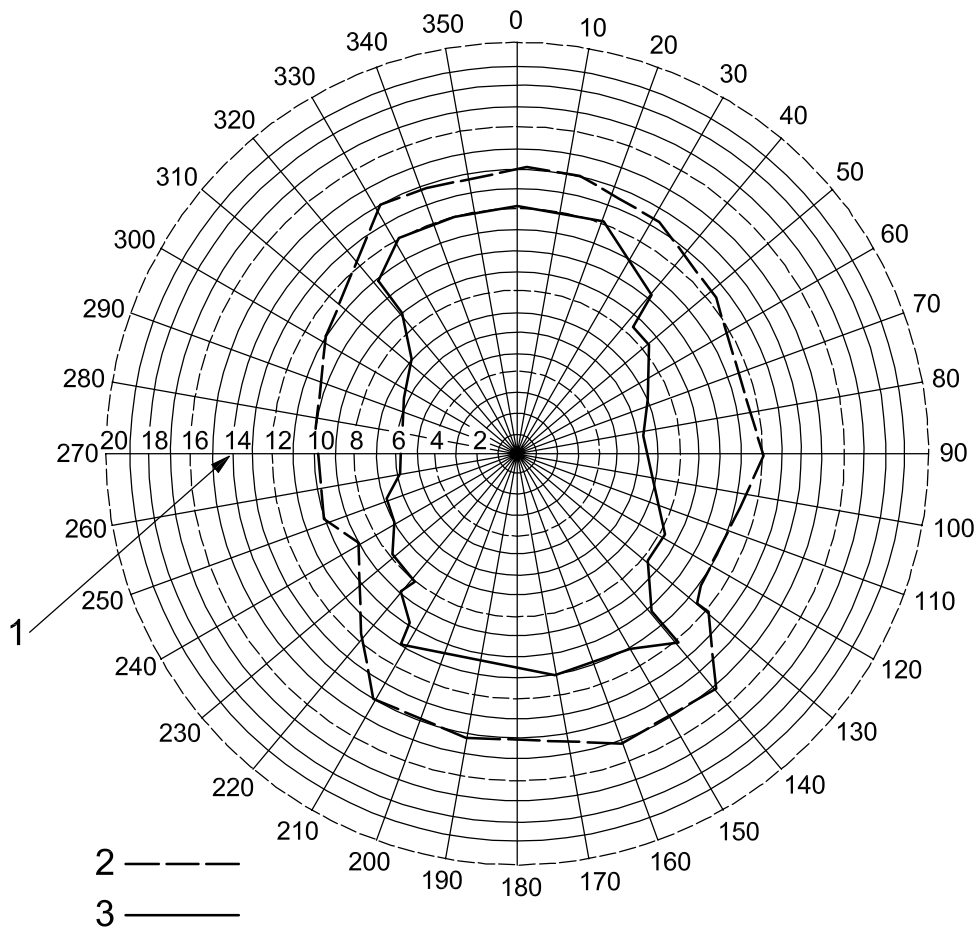

Key

- 1 distance (in metres) from test body
- 2 sporadic detection area
- 3 reliable detection area

Figure F.4 — Example plot of reliable and sporadic detection zones

F.9 Verification test for tag on a human

Human shielding of a tag can cause interference and missed detection. An additional test shall be conducted to verify that a tag intended to be worn by a human worker is detected in all orientations. The tag shall be worn on an average-sized person (height between 1,65 m and 1,75 m) in a typical orientation and location as recommended by the manufacturer. The test person shall stand upright facing the machine components mounted on the stand as described in F.5. The person shall stand on the intersection of the 180° radial line and the 8 m circle. Tag detection shall be recorded as “Yes” or “No” for this orientation. The test person shall then rotate his body in place in 45° increments, recording tag detection at each orientation. Results shall be recorded as shown in Table F.1.

Table F.1 — Recording of tag detection for person at range of 8 m

Person's orientation degrees	Tag detection Yes/No
0	
45	
90	
135	
180	
225	
270	
315	

F.10 Practical considerations for mounting EM transceiver systems on machines

The detection zone for these systems, when recorded as described above, could be very different to the detection zone that results after mounting the system on machinery. Interference from the metallic structures on the machine can block portions of the signal, resulting in a detection zone that is truncated in one or more directions. Mounting height and location can also affect the shape of the detection zone. Some manufacturers use this quality of EM signals to limit detection to one area of the machinery. For instance, an antenna mounted on the rear axle of a dump truck might only detect tags at the rear of the truck, and conversely for an antenna mounted on the front bumper. Manufacturers must make these limitations clear in the installation or operation manual so that it is understood that multiple antennas could be needed for full protection around a piece of machinery. It is recommended that manufacturers include an example plot of the detection area of the system when mounted on a typical piece of machinery.

F.11 Commissioning test for machine types

Because of the potential for metallic structures on the machine to block portions of the signal (see F.10), a commissioning test based on the method described in F.7 shall be carried out on each machine type to determine the limitations of detection of the system as installed on the machine. The results shall be recoded in accordance with F.8 and the plot compared with that obtained in the original component test. Where there is significant truncation of the signal, a risk assessment shall be used to determine whether multiple antennae are needed to provide additional protection to the areas of truncation.

Bibliography

- [1] ISO 3411, *Earth-moving machinery — Physical dimensions of operators and minimum operator space envelope*
- [2] ISO 5006, *Earth-moving machinery — Operator's field of view — Test method and performance criteria*
- [3] ISO/TR 9953, *Earth-moving machinery — Warning devices for slow-moving machines — Ultrasonic and other systems*
- [4] ISO 14401 (all parts), *Earth-moving machinery — Field of vision of surveillance and rear-view mirrors*
- [5] EN 50132-7:1996, *Alarm systems — CCTV surveillance systems for use in security applications — Application guidelines*
- [6] NIOSH RI 9652, *Test Results of Collision Warning Systems for Surface Mining Dump Trucks*
- [7] NIOSH RI 9654, *Test Results of Collision Warning Systems on Off-Highway Dump Trucks: Phase II*
- [8] NIOSH RI 9657, *Recommendations for Testing Radar-Based Collision Warning Systems on Heavy Equipment*

.....

ICS 53.100

Price based on 50 pages