Indoor air —

Part 10:

**Determination of the emission of volatile
organic compounds from building
products and furnishing — Emission test
cell method**

Air intérieur —

*Partie 10: Dosage de l'émission de composés organiques volatils de
produits de construction et d'objets d'équipement — Méthode de la
cellule d'essai d'émission*



Reference number
ISO 16000-10:2006(E)

© ISO 2006

PDF disclaimer

This PDF file may contain embedded typefaces. In accordance with Adobe's licensing policy, this file may be printed or viewed but shall not be edited unless the typefaces which are embedded are licensed to and installed on the computer performing the editing. In downloading this file, parties accept therein the responsibility of not infringing Adobe's licensing policy. The ISO Central Secretariat accepts no liability in this area.

Adobe is a trademark of Adobe Systems Incorporated.

Details of the software products used to create this PDF file can be found in the General Info relative to the file; the PDF-creation parameters were optimized for printing. Every care has been taken to ensure that the file is suitable for use by ISO member bodies. In the unlikely event that a problem relating to it is found, please inform the Central Secretariat at the address given below.

© ISO 2006

All rights reserved. Unless otherwise specified, no part of this publication may be reproduced or utilized in any form or by any means, electronic or mechanical, including photocopying and microfilm, without permission in writing from either ISO at the address below or ISO's member body in the country of the requester.

ISO copyright office
Case postale 56 • CH-1211 Geneva 20
Tel. + 41 22 749 01 11
Fax + 41 22 749 09 47
E-mail copyright@iso.org
Web www.iso.org

Published in Switzerland

Contents

Page

Foreword	iv
Introduction	vi
1 Scope	1
2 Normative references	1
3 Terms and definitions	1
4 Symbols and abbreviated terms	3
5 Principle	4
6 Emission test cell system	4
7 Apparatus	5
8 Test conditions	5
9 Verification of the test conditions	6
10 Test specimens	7
11 Emission test cell preparation	7
12 Test method	8
13 Calculation of area specific emission rates and expression of results	8
14 Performance characteristics	9
15 Test report	9
Annex A (normative) System for quality assurance/quality control	11
Annex B (informative) Examples of area specific air flow rates in a model room	13
Annex C (informative) Example of an emission test cell	14
Bibliography	16

Foreword

ISO (the International Organization for Standardization) is a worldwide federation of national standards bodies (ISO member bodies). The work of preparing International Standards is normally carried out through ISO technical committees. Each member body interested in a subject for which a technical committee has been established has the right to be represented on that committee. International organizations, governmental and non-governmental, in liaison with ISO, also take part in the work. ISO collaborates closely with the International Electrotechnical Commission (IEC) on all matters of electrotechnical standardization.

International Standards are drafted in accordance with the rules given in the ISO/IEC Directives, Part 2.

The main task of technical committees is to prepare International Standards. Draft International Standards adopted by the technical committees are circulated to the member bodies for voting. Publication as an International Standard requires approval by at least 75 % of the member bodies casting a vote.

Attention is drawn to the possibility that some of the elements of this document may be the subject of patent rights. ISO shall not be held responsible for identifying any or all such patent rights.

ISO 16000-10 was prepared by the European Committee for Standardization (CEN) Technical Committee CEN/TC 264, *Air quality*, in collaboration with Technical Committee ISO/TC 146, *Air quality*, Subcommittee SC 6, *Indoor air*, in accordance with the Agreement on technical cooperation between ISO and CEN (Vienna Agreement).

ISO 16000 consists of the following parts, under the general title *Indoor air*:

- *Part 1: General aspects of sampling strategy*
- *Part 2: Sampling strategy for formaldehyde*
- *Part 3: Determination of formaldehyde and other carbonyl compounds — Active sampling method*
- *Part 4: Determination of formaldehyde — Diffusive sampling method*
- *Part 5: Measurement strategy for volatile organic compounds (VOCs)*
- *Part 6: Determination of volatile organic compounds in indoor and test chamber air by active sampling on Tenax TA sorbent, thermal desorption and gas chromatography using MS/FID*
- *Part 7: Sampling strategy for determination of airborne asbestos fibre concentrations*
- *Part 8: Determination of local mean ages of air in buildings for characterizing ventilation conditions*
- *Part 9: Determination of the emission of volatile organic compounds from building products and furnishing — Emission test chamber method*
- *Part 10: Determination of the emission of volatile organic compounds from building products and furnishing — Emission test cell method*
- *Part 11: Determination of the emission of volatile organic compounds from building products and furnishing — Sampling, storage of samples and preparation of test specimens*

The following parts are under preparation:

- *Part 12: Sampling strategy for polycyclic aromatic hydrocarbons (PAHs), polychlorinated dibenzo-p-dioxins (PCDDs), polychlorinated dibenzo-furans (PCDFs) and polychlorinated biphenyls (PCBs)*

- *Part 13: Determination of total (gas and particle-phase) polychlorinated dioxin-like biphenyls and polychlorinated dibenzo-p-dioxins/dibenzofurans — Collection on sorbent-backed filters with high-resolution gas chromatographic/mass spectrometric analysis*
- *Part 14: Sampling strategy for nitrogen dioxide (NO₂)*
- *Part 15: Measurement of nitrogen dioxide (NO₂)*
- *Part 16: Detection and enumeration of moulds — Sampling of moulds by filtration*
- *Part 17: Detection and enumeration of moulds — Culture-based method*

Introduction

The determination of volatile organic compounds (VOCs) emitted from building products using emission test cells in conjunction with the standardised sampling, storage of samples and preparation of test specimens has objectives such as:

- to provide manufacturers, builders, and end users with emission data useful for the evaluation of the impact of building products on the indoor air quality;
- to promote the development of improved products;
- on-site investigation of building product surfaces.

The method can in principle be used for most building products used indoors.

Indoor air —

Part 10:

Determination of the emission of volatile organic compounds from building products and furnishing — Emission test cell method

1 Scope

This part of ISO 16000 specifies a general laboratory test method for determination of the area specific emission rate of volatile organic compounds (VOCs) from newly produced building products or furnishing under defined climate conditions. The method can in principle also be applied to aged products. The emission data obtained can be used to calculate concentrations in a model room.

According to the definition of an emission test cell, it is also possible to perform non-destructive emission measurements on building products on-site in buildings. However, the procedure for such measurements is not described in this part of ISO 16000.

Sampling, transport and storage of materials to be tested, and preparation of test specimens are described in ISO 16000-11. Air sampling and analytical methods for the determination of VOCs are described in ISO 16000-6 and ISO 16017-1^[20].

An example of an emission test cell is described in Annex C of this part of ISO 16000.

For the determination of formaldehyde emissions from wood-based panels, refer to EN 717-1:2004^[21] and ISO 12460-1^[1]. However, this part of ISO 16000 is also applicable to wood-based panels and other building products in order to determine the emission rate of formaldehyde. The measurement procedure for formaldehyde is described in ISO 16000-3^[2].

2 Normative references

The following referenced documents are indispensable for the application of this document. For dated references, only the edition cited applies. For undated references, the latest edition of the referenced document (including any amendments) applies.

ISO 554:1976, *Standard atmospheres for conditioning and/or testing — Specifications*

ISO 16000-11, *Indoor air — Part 11: Determination of the emission of volatile organic compounds from building products and furnishing — Sampling, storage of samples and preparation of test specimens*

3 Terms and definitions

For the purposes of this document, the following terms and definitions apply.

3.1

air change rate

ratio of the volume of clean air brought into the emission test chamber per hour and the free emission test chamber volume measured in identical units

- 3.2**
air flow rate
air volume entering into the emission test cell per time
- 3.3**
air velocity
air speed over the surface of the test specimen
- 3.4**
area specific air flow rate
ratio between the supply air flow rate and the area of the test specimen
- 3.5**
building product
product produced for incorporation in a permanent manner in construction works
- 3.6**
emission test cell
a small chamber for the determination of volatile organic compounds emitted from indoor materials/products that is placed on the surface of the test specimen and is designed so that the surface of the test specimen becomes a part of the emission cell
- 3.7**
emission test cell concentration
concentration of a specific volatile organic compound, VOC_x , (or groups of volatile organic compounds) measured in the emission test cell outlet
- 3.8**
product loading factor
ratio of exposed surface area of the test specimen and the free emission test cell volume
- 3.9**
recovery
measured mass of a target volatile organic compound in the air leaving the emission test cell during a given time period divided by the mass of target volatile organic compound added to the emission test cell in the same time period, expressed in percent
- NOTE The recovery provides information about the performance of the entire method.
- 3.10**
sample
part or piece of a building product that is representative of the production
- 3.11**
specific emission rate
 q_m
product specific rate describing the mass of a volatile organic compound emitted from a product per time at a given time from the start of the test
- NOTE 1 Area specific emission rate, q_A , is used in this part of ISO 16000. It describes the emitted volatile organic compounds per exposed area per time. (For other specific emission rates see Clause 4.)
- NOTE 2 The term area specific emission rate is sometimes used in parallel with the term emission factor.
- 3.12**
target volatile organic compound
product specific volatile organic compound

3.13**test specimen**

part of the sample specially prepared for emission testing in an emission test cell in order to simulate the emission behaviour of the material or product that is tested

3.14**total volatile organic compounds****TVOC**

sum of the concentrations of identified and unidentified volatile organic compounds eluting between and including *n*-hexane and *n*-hexadecane

NOTE 1 For quantification of the identified compounds, their individual responses are used. The areas of the unidentified peaks are converted on molecular mass basis to concentrations using the toluene response factor [3].

NOTE 2 Due to practical reasons to be taken into account for emission test chambers, this definition differs slightly from that in ISO 16000-6:2004. In ISO 16000-6, TVOC are related to the sampling medium Tenax TA^{®1)} on which the TVOC are adsorbed.

3.15**volatile organic compound****VOC**

organic compound that is emitted from the test specimen and all those detected in the test cell outlet air

NOTE 1 Due to practical reasons to be taken into account for emission test chambers, this definition differs from that in ISO 16000-6:2004. In ISO 16000-6, the definition is based on the boiling point range (50 °C to 100 °C) to (240 °C to 260 °C).

NOTE 2 The emission test method described in this part of ISO 16000 is optimum for the range of compounds specified by the definition of total volatile organic compounds (TVOC).

4 Symbols and abbreviated terms

The symbols and abbreviated terms used in this part of ISO 16000 are given below.

Symbol	Name	Unit
ρ_x	mass concentration of a VOC _x in the emission test cell	micrograms per cubic metre
L	product loading factor	square metres per cubic metre
n	air change rate	changes per hour
q	area specific air flow rate (= n/L)	cubic metres per square metre and hour
q_A	area specific emission rate	micrograms per square metre and hour
q_l	length specific emission rate	micrograms per metre and hour
q_m	mass specific emission rate	micrograms per gram and hour
q_V	volume specific emission rate	micrograms per cubic metre and hour
q_u	unit specific emission rate	micrograms per unit and hour
t	time after start of the test	hours or days

1) Tenax TA[®] is the trade name of a product manufactured by Supelco, Inc. This information is given for the convenience of users of this part of ISO 16000 and does not constitute an endorsement by ISO of the product named. Equivalent products may be used if they can be shown to lead to the same results.

5 Principle

The principle of the test is to determine the area specific emission rates of VOCs emitted from the surface of a product test specimen. The test is performed in an emission test cell at constant temperature, relative air humidity, and area specific air flow rate. Measurements of the VOC concentration in the air at the outlet are representative of the air in the emission test cell.

Area specific emission rates at a given time, t , are calculated from the emission test cell air concentrations and the area specific air flow rate, q (see Clause 13).

With knowledge of the concentration in the air, the air flow through the emission test cell, and the surface area of the test specimen, the area specific emission rates of VOCs from the product under test can be determined.

6 Emission test cell system

6.1 General

An emission test cell system designed and operated to determine area specific emission rates of VOCs from building products shall contain the following: emission test cell, clean air generation and humidification system, monitoring and control systems, to ensure that the test is carried out according to specified conditions [4], [5], [6], [7].

For solid products with smooth surface, the emission test cell is placed directly against the surface of the product test specimen. To secure air tightness, other products shall be placed in specially constructed test specimen holders.

General specifications and requirements that apply to all types of emission test cells in this part of ISO 16000 are given in 6.2 to 6.6 below.

Quality assurance / quality control activities shall be carried out as in Annex A.

6.2 Emission test cell materials

The emission test cell and the parts of the sampling system coming in contact with the emitted VOCs (all tubings and couplings) are normally made of surface treated (polished) stainless steel or glass. However, in all cases the requirements in 6.3 and 6.5 shall be fulfilled.

The sealing material that links together the emission test cell and the test specimen shall be low emitting and low adsorbing and shall not contribute to the emission test cell background concentration.

6.3 Air supply

The emission test cell shall be supplied with pure and humidified air and have a device for controlling the air flow rate with an accuracy of $\pm 5\%$.

6.4 Air tightness

The emission test cell shall be airtight in order to avoid uncontrolled air exchange with external air.

The emission test cell shall be operated slightly above atmospheric pressure to avoid any influence from the laboratory atmosphere.

The emission test cell is considered sufficiently tight if the inlet and outlet air flows differ by less than 5 %.

Products with a large air permeability or irregular surface may cause leakage. According to the demand for air tightness given above they shall therefore be placed in airtight test specimen holders.

6.5 Air sampling devices

The exhaust air (at the emission test cell outlet) shall be used for sampling. Sampling of the outlet air (e.g. with a sampling pump) is achieved by connecting adsorbent tubes to the outlet couplings.

The sum of sampling air flows shall be smaller than 90 % of the inlet air flow to the emission test cell.

A multiport sampling manifold can provide the flexibility for duplicate air sampling. The sampling manifold shall enter directly to the outlet air stream. If a duct shall be used, it shall be as short as possible and maintained at the same temperature as the emission test cell.

NOTE The exhaust from the emission test cell should be ducted into a fume hood, ensuring that any chemicals emitted from the test material are isolated from the laboratory environment.

6.6 Recovery and sink effects

The recovery of a target VOC can be determined using a VOC source of known specific emission rate in the emission test cell. The concentrations generated shall be of similar magnitude as those expected during the emission tests of building products.

Recovery tests shall be performed in the test cell on an inert surface (glass or stainless steel), using toluene and *n*-dodecane. Test cell air concentrations shall be determined at 24 h after start of the test. The mean recovery shall be greater than 80 % for toluene and *n*-dodecane. The results of this recovery test shall be reported in the test report as concentration expected versus concentration measured.

NOTE 1 Low recovery of hygroscopic VOCs may occur in humidified air.

NOTE 2 Sink effects, leaks or poor calibration can cause difficulties to meet the minimum requirements. Sink and adsorption characteristics are very much dependent on the type of compound emitted. Additional recovery tests using target VOCs with different molecular weight and polarity can be used to increase understanding of these effects.

7 Apparatus

The equipment necessary for carrying out an emission test are listed below.

7.1 Clean air supply, e.g. pressurised purified air or synthetic air in gas cylinders.

7.2 Emission test cell system.

7.3 Humidification system.

7.4 Air humidity and temperature monitoring systems.

7.5 Air flow meters.

7.6 Facilities for recovery testing.

7.7 Either cleaning agent for the emission test cell, or oven for heating and cleaning the emission test cell.

8 Test conditions

8.1 Temperature and relative air humidity

Products for use in Europe shall be tested at temperature and relative air humidity 23 °C, 50 % RH during the emission test (ISO 554). The tolerances are ± 2 °C and ± 5 % RH.

For products with applications under other climatic conditions alternative temperature and air humidity conditions may be used, preferably as specified in ISO 554.

8.2 Supply air quality and background concentration

Supply air shall not contain any VOCs at levels greater than the emission test cell background requirements.

Background concentrations shall be low enough not to interfere with the emission determinations beyond quality assurance limits.

The TVOC background concentration shall be lower than $20 \mu\text{g}/\text{m}^3$. The background concentration of any single target VOC shall be lower than $2 \mu\text{g}/\text{m}^3$.

The water used for humidification shall not contain interfering VOCs.

8.3 Air velocity

The calculated or measured air velocity over the surface of the test specimen shall be in the range of 0,003 m/s to 0,3 m/s.

NOTE The air velocity can be important for evaporative controlled emissions, e.g. from liquid products. This depends on the substrate.

EXAMPLE Examples of air velocities are given in Annex C.

8.4 Area specific air flow rate and air change rate

The emission test cell concentration depends on the area specific air flow rate that is selected as a parameter in designing the test conditions.

EXAMPLE Examples of area specific air flow rates are given in Annex B of this part of ISO 16000.

9 Verification of the test conditions

9.1 General

All control measures shall be traceable to a certified standard according to the quality assurance and quality control schemes (Annex A of this part of ISO 16000).

9.2 Temperature and relative air humidity control systems

Control of temperature can be made by placing the emission test cell within a location controlled to the required temperature.

Control of relative air humidity and temperature can be made by various systems with e.g. built-in humidity control of the supply air.

Temperature and relative air humidity shall be measured independently of the systems for controlling the temperature and relative air humidity.

9.3 Test conditions in the emission test cell

Temperature, relative air humidity, and air flow rate shall be measured with instruments meeting the following accuracy:

- temperature $\pm 1,0$ °C;
- relative air humidity ± 3 % RH;
- air flow rate ± 3 %.

The relative air humidity shall be measured at the air outlet. The temperature sensors shall be placed either in the emission test cell or in the air outlet.

9.4 Air velocity and air flow rate in the emission test cell

The air flow rate shall be checked and readjusted prior to air sampling using a calibrated gas flow meter. The air flow rates shall not vary by more than ± 5 % of the set value. The air velocity in the emission test cell shall be constant.

NOTE If the test is carried out with a gas volume meter / flow meter that is not permanently installed, be aware that the back pressure introduced by the meter can lower the flow rate through the emission test cell.

9.5 Emission test cell air tightness

The emission test cell air tightness shall be checked at the beginning of an emission test, by comparison of air flow rates at the inlet and the outlet ports, see 6.4.

10 Test specimens

Studies of the emission of VOCs from building products in emission test cells require proper handling of the product prior to testing.

Follow the procedures for test specimen preparation as specified in Annex A (for solid products) and in Annex B (for liquid products) of ISO 16000-11:2005.

11 Emission test cell preparation

The emission test cell shall be cleaned in accordance with either 11.1 or 11.2.

11.1 Cleaning by using a detergent

The emission test cell is cleaned by washing the inner surface with a diluted alkaline detergent, followed by two separate rinsings with freshly distilled water. Then wash the inner surface with non-denatured ethanol or other appropriate solvent.

11.2 Cleaning by thermal desorption

The emission test cell can also be cleaned by heating in a vacuum oven at elevated temperature (70 °C to 100 °C) over night.

12 Test method

12.1 Background concentrations

Place the emission test cell on a clean and planar surface (e.g. glass or stainless steel). An air sample of the emission test cell background is taken before the start of a new emission test to quantify any background contribution of volatile organic compounds from the empty emission test cell.

Background concentrations shall meet the requirements in 8.2.

12.2 Test specimen location in the emission test cell

The positioning of the emission test cell shall ensure that the direction of the air flow is evenly distributed over the emitting surface of the test specimen.

12.3 Time for measurements of emission test cell air concentration

The concentration measurements shall be carried out at predefined sampling times. Depending on the objective of the test, it can be appropriate to sample the air at additional times. Air sampling duration for concentration measurements depends on the analytical methods to be used and they shall be documented.

Duplicate air samples shall be taken at (72 ± 2) h and (28 ± 2) days after the start of the test.

After termination of the emission test, the emission test cell shall be cleaned according to Clause 11.

Emission test duration is determined by the purpose of the test. For long-term testing, the test specimen shall be stored under controlled conditions as prescribed in 8.1, if it is removed from the emission test cell. During this storage, the aging process of the test specimen shall be similar to that occurring in the test cell. Any contamination by other stored test specimens has to be avoided. The test specimen shall then be re-introduced into the test cell at least 24 h prior to air sampling. Each removal of the test specimen has to be documented in the test protocol.

NOTE 1 If decay studies are required, air samples can be taken after 1, 3, 7, 14, 28 and 56 days, or longer, after the start of the test.

Background concentrations of VOCs should be sufficiently controlled in order to avoid contamination of test specimens.

NOTE 2 To minimize contamination of test specimens between testing times, well ventilated shelves or storage cabinets can be used.

13 Calculation of area specific emission rates and expression of results

At a given test condition, ρ_x depends on the area specific emission rate of the test specimen and the air flow rate through the emission test cell. For individual VOCs, the compounds found both in the material and in the background shall be subtracted compound by compound. For TVOC, the measured background shall be subtracted. The relation between ρ_x , the area specific emission rate (q_A) and the area specific air flow rate (q) of the emission test cell can be expressed as:

$$\rho_x = q_A \cdot (L/n) = q_A / q \quad (1)$$

Equation (1) shows that the area specific air flow rate, q , equals the n/L ratio. For a given product tested under given emission test cell conditions, the concentration of VOC_x depends on the area specific air flow rate.

The measured concentration, ρ_x , of a VOC in the outlet air from the emission test cell shall be converted to an area specific emission rate, q_A . ρ_x is the mean concentration of a VOC_x calculated from a duplicate air samples as described in 12.3.

$$q_A = \rho_x \cdot q \quad \text{at time } t \quad (2)$$

The result shall be related to the time of the emission measurement after placing the test specimen in the emission test cell and may be reported quantitatively as the area specific emission rate, of individual VOCs and/or TVOC according to the objective of the test.

The sum of emitted compounds, TVOC, should be regarded only as a factor specific to the product studied and only to be used for comparison of products with similar target VOC profiles.

NOTE For certain purposes, area specific emission rates can be calculated from time concentration profiles, or by means of various mathematical models, e.g. first-order decay from concentration time data. This and other models are referred to in References [8] and [9].

14 Performance characteristics

Performance characteristics of this test method when used in conjunction with ISO 16000-6, are discussed in ISO 16000-6 and ISO 16017-1.

15 Test report

The test report shall include the following information:

- a) test laboratory:
 - 1) name and address of the laboratory;
 - 2) name of the responsible person;
 - 3) description of the equipment and methods used (test cell, clean air system, environmental control, sample collection, analytical instrumentation, standard generation and calibration);
- b) sample description:
 - 1) type of product (and brand name if appropriate);
 - 2) sample selection process (e.g. random);
 - 3) product history (date of production, date of arrival to the test laboratory);
- c) test specimen preparation:
 - 1) date and time of unpacking and test specimens preparation (hour, day, month and year);
 - 2) method of preparation, including thickness and substrate, including for liquid products the substrate, the amount per unit area, and/or the thickness;
- d) experimental conditions and procedures:
 - 1) test cell conditions (temperature, relative air humidity, air change rate, air velocity);
 - 2) test specimen area and loading ratio;
 - 3) sampling of emitted compounds (adsorbent used, volume sampled, sampling duration and times after introduction into the cell);

e) data analysis:

describe the method used to derive specific emission rates from measured cell concentrations (specify mathematical models or equations used);

f) results:

specific emission rates shall be reported for each test specimen, for individual VOCs and/or TVOC, at the times of air sampling;

g) quality assurance / quality control:

- 1) background test cell concentrations of target compounds;
- 2) recovery data of toluene and *n*-dodecane (to evaluate sinks);
- 3) results of duplicate sampling/analysis;
- 4) quality of the environmental variables (temperature, relative air humidity, air change rate, air velocity).

Annex A (normative)

System for quality assurance/quality control

A.1 General

Emission cell testing of organic emissions from indoor materials/products shall be conducted within the framework of a Quality Assurance Project Plan (QAPP). The QAPP shall contain a project description, data quality objectives/acceptance criteria, QA/QC approaches/activities, and QA/QC audits.

A.2 Project description

A brief description shall include what materials are to be tested; how the testing is to be conducted; and who is responsible for various project activities. The project experimental design shall contain the necessary information for this portion of the QAPP.

A.3 Data quality objectives/Acceptance criteria

This section of the QAPP defines the precision, accuracy, and completeness desired for each parameter being measured.

A.4 QA/QC Approaches/Activities ^[10]

The types of QA/QC activities that can be specified in the QAPP include establishment of a system of records/notebooks to ensure proper operation of equipment and recording of data, such as:

- a) sample log to record receipt, storage, and disposition of materials;
- b) GC standards preparation log to document preparation of all organic compound substances;
- c) permeation tube log to record weight loss data for all permeation tubes;
- d) calibration logs to contain environmental systems calibration data;
- e) instrument maintenance logs to document maintenance and repairs of all equipment;
- f) materials testing logs in which to record all pertinent information for each test, including sample details, sample ID number, and GC run ID number;
- g) sorbent cartridge cleanup/desorption log detailing thermal cleanup and QC validation of sorbent cartridges;
- h) separate electronic log to document location and content of electronically stored data;
- i) manuals governing operation of all equipment used by the project.

QC activities are carried out by project staff in a routine, consistent manner to provide necessary feedback in operation of all measurement systems. Such activities can include:

- routine maintenance and calibration of systems;
- daily recording of GC calibration accuracy and precision (i.e. control charting);
- timely monitoring of percent recovery of the internal standard that was added to all samples;
- collection and analysis of duplicate samples;
- QC checking of organic collection sorbent tubes;
- periodic analysis of audit gases supplied by an independent source.

A.5 QA/QC Audits

Finally, the QA/QC program shall include periodic audits by QA personnel to evaluate compliance with QAPP protocols.

Annex B (informative)

Examples of area specific air flow rates in a model room

Table B.1 — Examples of area specific air flow rates in a model room

Model room ^a	Area specific air flow rate $\text{m}^3/(\text{m}^2\cdot\text{h})$ or n/L
17,4 m ³ , $n = 0,5 \text{ h}^{-1}$:	
Floor area = 7 m ²	1,2
Wall area = 24 m ²	0,4
Sealant area = 0,2 m ²	44
^a See Reference [5].	

NOTE A calculated concentration may differ from reality. Also one should remember that the figure of emission rate is a mean for one hour, but one day later the emission may have changed many times.

Annex C (informative)

Example of an emission test cell

Volume (m ³)	3,5 × 10 ⁻⁵	—	—	—
Maximum exposed test surface area (m ²)	0,017 7	—	—	—
Inlet air slit (mm)	1,0	—	—	—
Diameter (mm)	150	—	—	—
Height at centre (mm)	18	—	—	—
Maximum material loading (m ² /m ³)	507	—	—	—
Airflow rate (l/min)	0,100	0,300	1,400	2,800
Air change rate, <i>n</i> (h ⁻¹)	171	514	2 400	4 800
Air velocity ^a at slit (m/s)	0,003 5	0,01	~ 0,05	~ 0,1
Area specific airflow rate ^b [m ³ /(h·m ²)]	0,34	1	5	9
Reynolds number (20°C), <i>Re</i>				10
Wall surface micro structure ^c <i>R_a</i> (µm)	< 0,1			
Wall sink		Time to reach cell equilibrium for polar VOCs < 2 h at an air supply of 400 ml/min (air velocity ≈ 0,014 m/s)		
Recovery percentage of VOC (%) ^d				
Dodecane	106 ± 2			
2-Ethylhexanol	99 ± 2			

^a Calculated according to the geometry and airflow.

^b Total exposed area of the test specimen.

^c Inner surface is hand polished → uniform surface microstructure, *R_a* = Roughness value (see ISO 1302-02 [19]).

^d The air supply was 100 ml/min at 50% relative air humidity, but for 2-ethylhexanol, 0% relative air humidity was used instead.

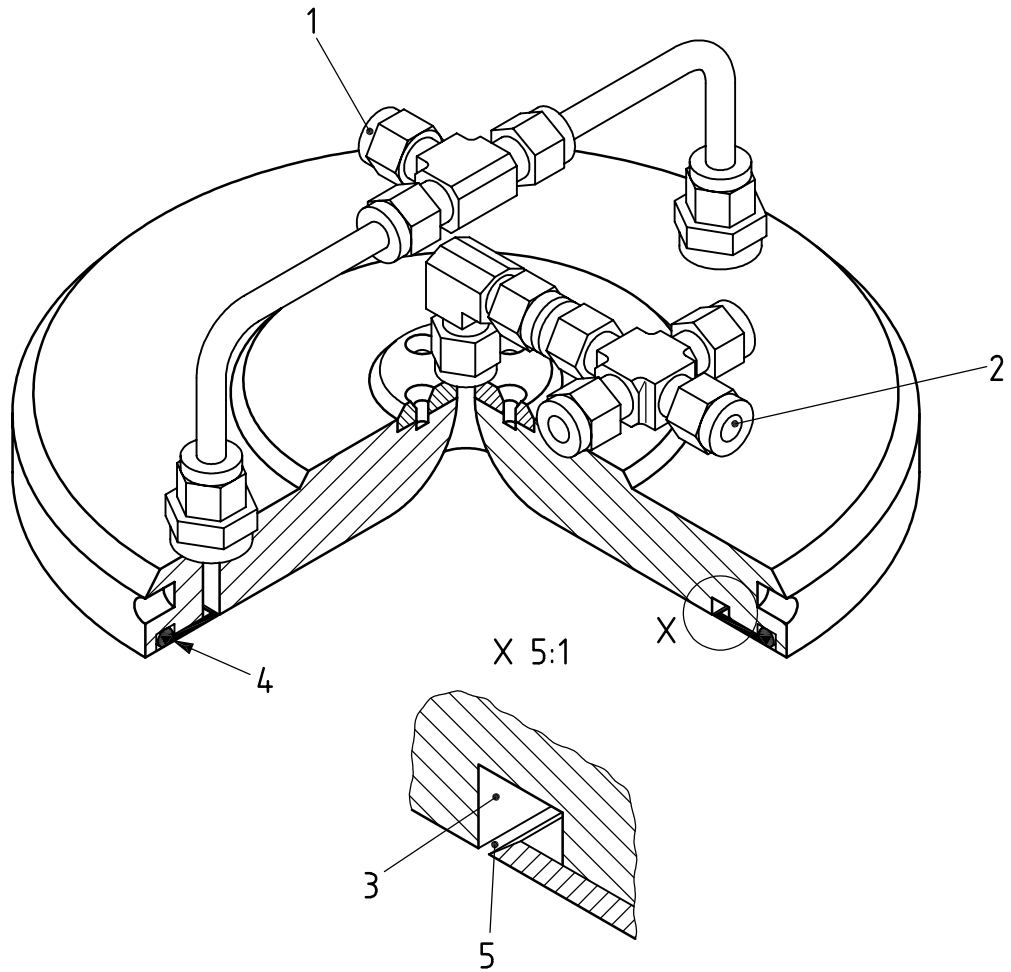

Key

- 1 air inlet
- 2 air outlet
- 3 channel
- 4 sealing material
- 5 slit

NOTE For further information, see References [11] to [19].

Figure C.1 — Description of an example of an emission test cell — General description in three dimensions of the field and laboratory emission cell

Bibliography

- [1] ISO 12460-1:—²⁾, *Wood-based panels — Determination of formaldehyde release — Part 1: Formaldehyde emission by the 1-cubic metre chamber method*
- [2] ISO 16000-3:2001, *Indoor air — Part 3: Determination of formaldehyde and other carbonyl compounds — Active sampling method*
- [3] ECA (European Collaborative Action "Indoor Air Quality and its Impact on Man"). *Total Volatile Organic Compounds (TVOC) in Indoor Air Quality Investigations*. Report No. 19, EUR 17675 EN. Luxembourg: Official Publications of the European Communities, 1997
- [4] ECA (European Collaborative Action "Indoor Air Quality and its Impact on Man"). *Evaluation of VOC Emissions from Building Products - Solid Flooring Materials*. Report No. 18, EUR 17334 EN. Luxembourg: Official Publications of the European Communities, 1997
- [5] Danish Standard/INF 90 "Directions for the determination and evaluation of the emission from building products" (*Anvisning for bestemmelse og vurdering af afgangning fra byggevarer*), Dansk Standard, København, 1994
- [6] ECA, European Collaborative Action - Indoor Air Quality and Its Impact on Man, COST Project 613, *Guideline for the Characterization of Volatile Organic Compounds Emitted from Indoor Materials and Products Using Small Test Chambers*, EUR 13593 EN, Report No 8, Commission of the European Communities, 1991, Joint Research Centre
- [7] NIELSEN, P.A., JENSEN, L.K., ENG, K., BASTHOLM, P., HUGOD, C., HUSEMOEN, T., MØLHAVE, L., WOLKOFF, P. (1994) *Health-Related Evaluation of Building Products based on Climate Chamber Tests*, *Indoor Air* 1994, **4**, pp. 146-153
- [8] TICHENOR, B.A. *Indoor air sources; using small environmental test chambers to characterize organic emissions from indoor materials and products*, EPA-600 8-89-074, Air and Energy Engineering Research Laboratory, U.S. Environmental Protection Agency, 1989., Section 6C
- [9] ECA, European Collaborative Action - Indoor Air Quality and Its Impact on Man, COST Project 613, *Formaldehyde Emissions from Wood Based Panels: Guideline for the establishment of Steady state Concentrations in Test Chambers*, Report No 2, EUR 12196 EN, Commission of the European Communities, Joint Research Centre
- [10] TICHENOR, B.A. *Indoor air sources; using small environmental test chambers to characterize organic emissions from indoor materials and products*, EPA-600 8-89-074, Air and Energy Engineering Research Laboratory, U.S. Environmental Protection Agency, 1989, Section 7
- [11] GUSTAFSSON, H. and JONSSON, B. "Review of small devices for measuring chemical emission from materials", Report 1991:25, Swedish National Testing and Research Institute, Borås, 1991
- [12] ROACHE, N., GUO, Z., FORTMANN, R. and TICHENOR, B.A. *Comparing the Field and Laboratory Emission Cell (FLEC) with Traditional Emissions Testing Chambers*. TICHENOR, B. (ed) *Characterizing Sources of Indoor Air Pollution and Related Sink Effects*, Philadelphia, ASTM STP 1287, 1996, pp. 98-111

2) To be published.

- [13] WOLKOFF, P. *An emission cell for measurement of volatile organic compounds emitted from building materials for indoor use - the field and laboratory emission cell FLEC³⁾*, *Gefahrstoffe - Reinhaltung der Luft*, **56**, 1996, pp. 151-157
- [14] WOLKOFF, P., CLAUSEN, P.A. and NIELSEN, P.A. *Application of Field and Laboratory Emission Cell "FLEC" - Performance Study, Intercomparison Study, and Case Study of Damaged Linoleum*, *Indoor Air*, **5**, 1995, pp. 196-203
- [15] WOLKOFF, P., CLAUSEN, P.A., NIELSEN, P.A. and GUNNARSEN, L. *"Documentation of Field and Laboratory Emission Cell "FLEC" - Identification of Emission Processes from Carpet, Linoleum, Paint, and Sealant by Modelling"*, *Indoor Air*, **3**, 1993, pp. 291-297
- [16] WOLKOFF, P., CLAUSEN, P.A., NIELSEN, P.A., GUSTAFSSON, H., JONSSON, B. and RASMUSEN, E. *Field and Laboratory Emission Cell: FLEC*, *Healthy Buildings '91*, American Society of Heating, Refrigerating, and Air-Conditioning Engineers, Atlanta, 1991, pp 160-165
- [17] WOLKOFF, P. *Impact of air velocity, temperature, humidity, and air on long-term VOC emissions from building products*", *Atmospheric Environment*, **32**, 1998, pp. 1-11
- [18] Additional information about FLEC^{® 3)} applications can be found on the internet address: <http://www.flec.com>
- [19] ISO 1302:2002, *Geometrical Product Specifications (GPS) — Indication of surface texture in technical product documentation*
- [20] ISO 16017-1:2000, *Indoor, ambient and workplace air — Sampling and analysis of volatile organic compounds by sorbent tube/thermal desorption/capillary gas chromatography — Part 1: Pumped sampling*
- [21] EN 717-1:2004, *Wood-based panels — Determination of formaldehyde release — Part 1: Formaldehyde emission by the chamber method*

3) FLEC[®] is the trade name of a product manufactured by CHEMATEC. This information is given for the convenience of users of this part of ISO 16000 and does not constitute an endorsement by ISO of the product named. Equivalent products may be used if they can be shown to lead to the same results.

ICS 13.040.20

Price based on 17 pages