

INTERNATIONAL STANDARD

ISO 15996

First edition
2005-04-01

Gas cylinders — Residual pressure valves — General requirements and type testing

*Bouteilles à gaz — Robinets à pression résiduelle — Exigences
générales et essais de type*



Reference number
ISO 15996:2005(E)

© ISO 2005

PDF disclaimer

This PDF file may contain embedded typefaces. In accordance with Adobe's licensing policy, this file may be printed or viewed but shall not be edited unless the typefaces which are embedded are licensed to and installed on the computer performing the editing. In downloading this file, parties accept therein the responsibility of not infringing Adobe's licensing policy. The ISO Central Secretariat accepts no liability in this area.

Adobe is a trademark of Adobe Systems Incorporated.

Details of the software products used to create this PDF file can be found in the General Info relative to the file; the PDF-creation parameters were optimized for printing. Every care has been taken to ensure that the file is suitable for use by ISO member bodies. In the unlikely event that a problem relating to it is found, please inform the Central Secretariat at the address given below.

© ISO 2004

All rights reserved. Unless otherwise specified, no part of this publication may be reproduced or utilized in any form or by any means, electronic or mechanical, including photocopying and microfilm, without permission in writing from either ISO at the address below or ISO's member body in the country of the requester.

ISO copyright office
Case postale 56 • CH-1211 Geneva 20
Tel. + 41 22 749 01 11
Fax + 41 22 749 09 47
E-mail copyright@iso.org
Web www.iso.org

Published in Switzerland

Contents

Page

Foreword	iv
Introduction	v
1 Scope	1
2 Normative references	1
3 Terms and definitions	1
4 Valve requirements	2
4.1 General	2
4.2 Description	2
4.3 Valve outlet geometry	2
4.4 Performance requirements of the residual pressure device	3
4.4.1 Leakage tightness	3
4.4.2 Endurance	3
4.4.3 Resistance against reverse over pressure	3
4.4.4 Resistance to ignition	3
5 Type testing	3
5.1 General	3
5.2 Documents	4
5.3 Test valves	4
5.4 Residual pressure device performance tests	5
5.4.1 General	5
5.4.2 Leak tightness tests	5
5.4.3 Cycle life test	5
5.4.4 Resistance test against reverse over-pressure	5
5.4.5 Oxygen pressure surge test	5
5.5 Test report	6
Annex A (informative) Various examples of residual pressure valve designs	7
Annex B (informative) Test equipment	10
B.1 Tightness test equipment for residual pressure valve	10
B.2 Cycle life test equipment for residual pressure valve	11
Annex C (informative) Conveyance test	12
Annex D (informative) Integrity under high flow	13
Bibliography	15

Foreword

ISO (the International Organization for Standardization) is a worldwide federation of national standards bodies (ISO member bodies). The work of preparing International Standards is normally carried out through ISO technical committees. Each member body interested in a subject for which a technical committee has been established has the right to be represented on that committee. International organizations, governmental and non-governmental, in liaison with ISO, also take part in the work. ISO collaborates closely with the International Electrotechnical Commission (IEC) on all matters of electrotechnical standardization.

International Standards are drafted in accordance with the rules given in the ISO/IEC Directives, Part 2.

The main task of technical committees is to prepare International Standards. Draft International Standards adopted by the technical committees are circulated to the member bodies for voting. Publication as an International Standard requires approval by at least 75 % of the member bodies casting a vote.

Attention is drawn to the possibility that some of the elements of this document may be the subject of patent rights. ISO shall not be held responsible for identifying any or all such patent rights.

ISO 15996 was prepared by Technical Committee ISO/TC 58, *Gas cylinders*, Subcommittee SC 2, *Cylinder fittings*.

Introduction

Gas cylinders are fitted with valves, to contain and control the discharge of their contents.

Increased requirements about avoidance of contamination of gases and gas cylinders has led to the development of gas cylinder valves incorporating residual pressure devices.

These devices are designed to maintain a small positive differential pressure between the inlet and the outlet of the cylinder valve. This prevents the gas cylinder from being completely empty in customer use and stops ingress of atmospheric contamination.

Many of these devices include a non-return function that protects the cylinder from back flow from downstream processes.

1

Gas cylinders — Residual pressure valves — General requirements and type testing

1 Scope

This International Standard specifies requirements for residual pressure valves, with or without a non-return function, for gas cylinders and the methods of testing such valves, for type approval.

This International Standard is applicable to valves to be fitted to gas cylinders of up to 150 l water capacity, intended to contain compressed, liquefied or dissolved gases.

This International Standard does not cover valves for fire extinguishers, cryogenic equipment or liquefied petroleum gas.

These requirements are in addition to those laid down in ISO 10297.

2 Normative references

The following referenced documents are indispensable for the application of this document. For dated references, only the edition cited applies. For undated references, the latest edition of the referenced document (including any amendments) applies.

ISO 10156, *Gases and gas mixtures — Determination of fire potential and oxidizing ability for the selection of cylinder valve outlets*

ISO 10297:1999, *Gas cylinders — Refillable gas cylinder valves — Specification and type testing*.

3 Terms and definitions

For the purposes of this document the following terms and definitions apply.

3.1 working pressure

p_w

settled pressure, at a uniform temperature of 15 °C, for a full gas cylinder

3.2 valve test pressure

p_{vt}

for compressed gases $p_{vt} = 1,2 \times p_w$ and for liquefied gases and dissolved gases under pressure (e.g. acetylene), p_{vt} is greater or equal to the minimum test pressure of the cylinder quoted in the relevant transportation regulation for that gas or gas group and filling ratio

3.3 flow direction

path taken through the valve by the gas when flowing out of the cylinder through the outlet

3.4

filling direction

path taken through the valve by the gas when filling from the outlet into the gas cylinder

3.5

opening pressure

differential pressure between upstream and downstream pressures at which the residual pressure device starts to open

NOTE Due to the effects of manufacturing tolerances this is normally expressed as a range of pressures.

3.6

closing off pressure

differential pressure between upstream and downstream pressures at which the residual pressure device closes

NOTE Due to the effects of manufacturing tolerances this is normally expressed as a range of pressures.

4 Valve requirements

4.1 General

Valves shall operate satisfactorily over the full range of service temperatures, normally from $-20\text{ }^{\circ}\text{C}$ to $+65\text{ }^{\circ}\text{C}$. The range may be exceeded for short periods (e.g. during filling). Where higher or lower service temperatures are required for longer periods, the purchaser shall specify them accordingly.

Valves shall be capable of withstanding the mechanical stresses or chemical attack they may experience during normal service e.g. during storage, valving into cylinders, filling processes, transportation and end use of the cylinder.

Valves shall be cleaned to meet the requirements of the intended service. However, valves to be tested shall be in a condition that the manufacturer intends to supply, prior to any test or test preparation.

4.2 Description

There are currently two main types of residual pressure valves (see Figures A.1 and A.2). The valve shown in Figure A.1 leaves a small positive or residual pressure in the cylinder. The valve shown in Figure A.2 not only leaves a small positive pressure, but also incorporates a non-return function to prevent back-flow into the cylinder from a higher pressure source.

The valve shown in Figure A.2 requires either an adapter or a manual adjustment to overcome the non-return function for filling, whereas the valve shown in Figure A.1 usually does not.

Two other schematic designs are shown in Annex A.

4.3 Valve outlet geometry

The residual pressure device, if placed in a valve outlet, shall be designed so that it does not interfere with a gas withdrawal connection made in accordance with the relevant national or international standard.

The diameter of the gas passage between the valve outlet and the body of the valve is permitted to be larger than is quoted in the relevant standard provided safety is not compromised.

4.4 Performance requirements of the residual pressure device

4.4.1 Leakage tightness

The leak rate for residual pressure devices shall not exceed 6 cm³/h at 20 °C and 1 013 mbar when tested at 0,5 bar and a room temperature normally between 15 °C and 30 °C.

NOTE Leakage rate may vary at extremes of temperature. Therefore it should be considered for acceptability for individual applications.

Test details are given in 5.4.2.

4.4.2 Endurance

Residual pressure devices shall perform to the manufacturer's specification for opening and closing-off pressures over a life of at least 100 000 cycles. This requirement is in addition to any cycle tests required to satisfy the endurance test specified in ISO 10297, where the cylinder valve is to be tested with the residual pressure device neutralized using the manufacturer's recommended method or by using a valve not fitted with the residual pressure device.

The test cycle is described in 5.4.3.

Leakage rate at the end of the test cycle shall not exceed 6 cm³/h at 20 °C and 1 013 mbar when tested at 0,5 bar and a room temperature normally between 15 °C and 30 °C.

4.4.3 Resistance against reverse over pressure

Where a residual pressure valve incorporates a non-return function, this shall be able to resist a reverse pressure of $1,5 \times p_{vt}$.

The test is described in 5.4.4.

4.4.4 Resistance to ignition

Residual pressure valves for oxygen and highly oxidizing gases as defined in ISO 10156 shall be subjected to an oxygen pressure surge test in accordance with the requirements of 5.4.5.

After the test, valves shall show no evidence of ignition.

NOTE In addition, the design should ensure that the valve will resist ignition in normal service conditions, in particular under certain flow conditions vibration (noise) can occur which may be a cause of ignition.

5 Type testing

5.1 General

Before valves are introduced into service, they shall be submitted for type testing. Type testing is valid for a given family of valves having the same basic design.

Variations to connections do not require further type testing.

Changes to the basic dimensions of components or changes of material for reasons of compatibility of the material with gases (e.g. O-ring, packing, diaphragm, spindle, lubricant) constitute a type variant within the given family.

Type variants require repetition of the relevant parts of the type test.

Changes of the basic design dimensions of components or changes of valve body material, constitute a new family and require the full type test.

Where valves require a device to neutralize the residual pressure functions for filling the device used in type testing, these shall operate in a manner approved by the manufacturer.

5.2 Documents

The manufacturer shall make available, when necessary, the following documents:

- a set of drawings consisting of the general arrangement (residual pressure valve and the main part of the filling adapter), parts list, material specifications and detail drawings; any type variant, within the given family, shall be clearly identified;
- description of valve and method of operation including details of opening pressure of the residual pressure device and closing-off pressures of the residual pressure device at specified flow rates;
- information on the field of application of the residual pressure valve (gases and gas mixtures, pressures etc.);
- certificates of material compatibility as required.

5.3 Test valves

A minimum of five samples of residual pressure valves is required in addition to those necessary for the test sequences of ISO 10297 (see Table 1). More samples may be necessary, depending on the number of type variants to be tested.

Table 1 — Test valve sequences
(examples with no variant and one or two variants)

Test sequence	Test and sub-clause No.	Valve sample number in the case of no variant	Number of tests in the case of no variant	Valve sample number with one type variant (a)	Number of tests in the case of one type variant (a)	Valve sample number with two type variants (b) and (c)	Total Number of tests with two type variants (b) and (c)
1	Leak tightness 5.4.2	1 to 5	5	1 to 3 4a and 5a	5	1 and 2 3b and 4b 5c and 6c	6
2	Cycle life test 5.4.3	1 to 3	3	1 and 2 3a	3	1 2b 3c	3
3	Resistance test against reverse over-pressure 5.4.4	4 and 5	2	4 5a	2	4 5b 5c	3
4	Oxygen pressure surge test 5.4.5	6 to 8	3	6 to 8 6a to 8a	6	6 to 8 6b to 8b 6c to 8c	9

NOTE For a given type of valve, normally only one type (or variant) is intended for oxygen service. In the above table it was assumed that the main type and the variant(s) are all for oxygen service. This is unlikely but chosen to indicate the maximum number of tests that might have been to be performed.

5.4 Residual pressure device performance tests

5.4.1 General

Before beginning tests, the closing-off pressure and the opening pressure of all test sample valves shall be measured and checked against the manufacturer's specifications.

This test is performed at room temperature with N₂ or air and, if required, the service gas.

An example of test equipment for this test is shown in Figure B.1.

Test sample valves cannot be introduced into service.

5.4.2 Leak tightness tests

A minimum of 5 samples is required with a minimum of 2 samples per type variant:

- a) with the main valve orifice open, a pressure of 0,5 bar is to be applied in the flow direction;
- b) if the valve incorporates a non-return function, a pressure shall also be applied in the filling direction to continuously increase the pressure from 0,1 bar to p_{VT} .

These tests shall be carried out at room temperature normally between 15 °C and 30 °C and at the extremes of the temperature range specified in 4.1. Leakage rates measured are to be recorded.

5.4.3 Cycle life test

A minimum of 3 samples is required with a minimum of one sample per type variant.

The residual pressure device shall be cycled from closing-off pressure to 2 × the maximum specified opening pressure or 10 bar whichever is the greater. The cycle time shall be set between 3 s and 10 s. A device may be used for visual indication that the residual pressure device opens and closes. Leakage rate at ambient temperature should be measured at 10 000 cycle intervals [see 5.4.2 a)].

At the completion of the test the leakage rate shall be measured [see 5.4.2 a) and b)] and the closing-off and opening pressures measured, recorded and checked in accordance with 5.4.1.

An example of test equipment for cycle life test is shown in Figure B.2.

5.4.4 Resistance test against reverse over-pressure

A minimum of 2 samples is required with a minimum of 1 sample per type variant.

The residual pressure valve shall be tested by hydraulically pressurizing in the filling direction, without neutralization of the residual pressure device. The test pressure is $1,5 \times p_{VT}$. The rate of the pressure increase shall be less than or equal to 600 bar/min. No destructive failure shall occur during a period of 2 min.

5.4.5 Oxygen pressure surge test

For this test 3 samples of each variant are required.

The oxygen pressure surge test and the acceptance criteria shall be in accordance with the requirements of ISO 10297.

The following tests shall be performed in the filling direction.

- a) Valve designs requiring neutralization of the residual pressure device for filling (type B):
- valve operating system closed, residual pressure device neutralized;
 - valve operating system open, residual pressure device neutralized, stem passage sealed with a screwed metallic plug;
 - valve operating system open, residual pressure device not neutralized, stem passage sealed with a screwed metallic plug;
 - valve operating system closed, residual pressure device not neutralized.
- b) Valve designs not requiring neutralization of the residual pressure device for filling (type A):
- valve operating system closed;
 - valve operating system open, stem passage sealed with a screwed metallic plug.

WARNING — Valves tested in accordance with this International Standard are intended to be used in gas cylinders only. If they were to be used for other applications (e.g. bundle master valves or manifold stop valve, etc.), additional oxygen surge tests would be necessary to assure their safety.

5.5 Test report

A written report shall be prepared summarizing all the tests carried out and the results obtained. The report shall be obtainable from the valve manufacturer on request. This report shall be signed by the responsible person(s) carrying out the tests and shall include:

- a) a set of drawings consisting of a general arrangement, parts list, material specifications and detailed drawings; any type variant, within the given family, shall be clearly identified;
- b) description of valve and method of operation;
- c) information on the field of application of the valve (gases and gas mixtures, pressures, use with or without valve protection device, etc.); it shall be clearly indicated which gases and gas mixtures can be used with each type variant;
- d) evidence of material compatibility as required.

Annex A (informative)

Various examples of residual pressure valve designs

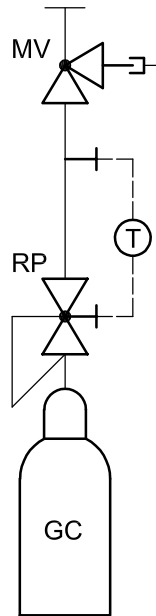

Key

- MV main valve
- RP residual pressure device
- GC gas cylinder
- T tool

Figure A.1 — Special tool needed to operate residual pressure valve during evacuation

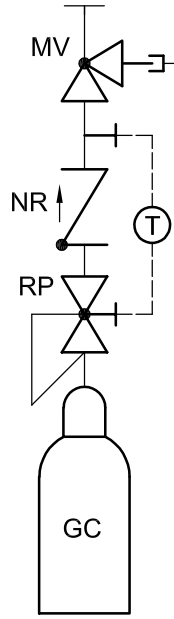

Key

- MV main valve
- RP residual pressure device
- NR non-return valve
- GC gas cylinder
- T tool

Figure A.2 — Special tool needed to operate residual pressure valve during filling and during evacuation

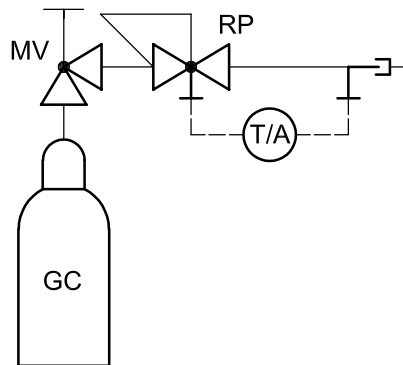

Key

- MV main valve
- RP residual pressure device
- GC gas cylinder
- T tool
- A magnet

Figure A.3 — Special filling connector needed for evacuation

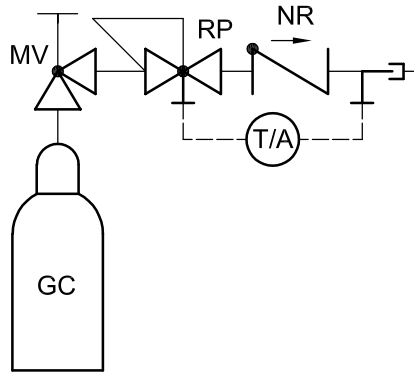

Key

- MV main valve
- RP residual pressure device
- GC gas cylinder
- NR non-return valve
- T tool
- A magnet

Figure A.4 — Special connector needed for filling and evacuation

Annex B (informative)

Test equipment

B.1 Tightness test equipment for residual pressure valve

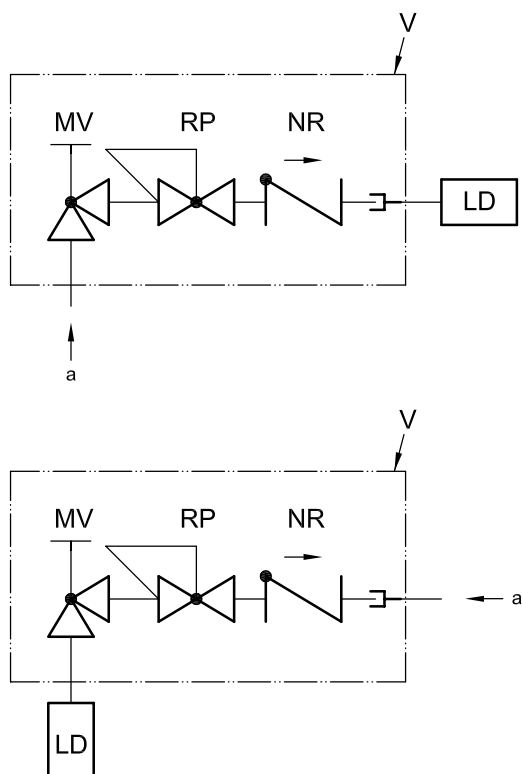

Key

- MV main valve
- RP residual pressure device
- NR non-return valve
- LD leak detector
- V valve
- a Gas in.

Figure B.1

B.2 Cycle life test equipment for residual pressure valve

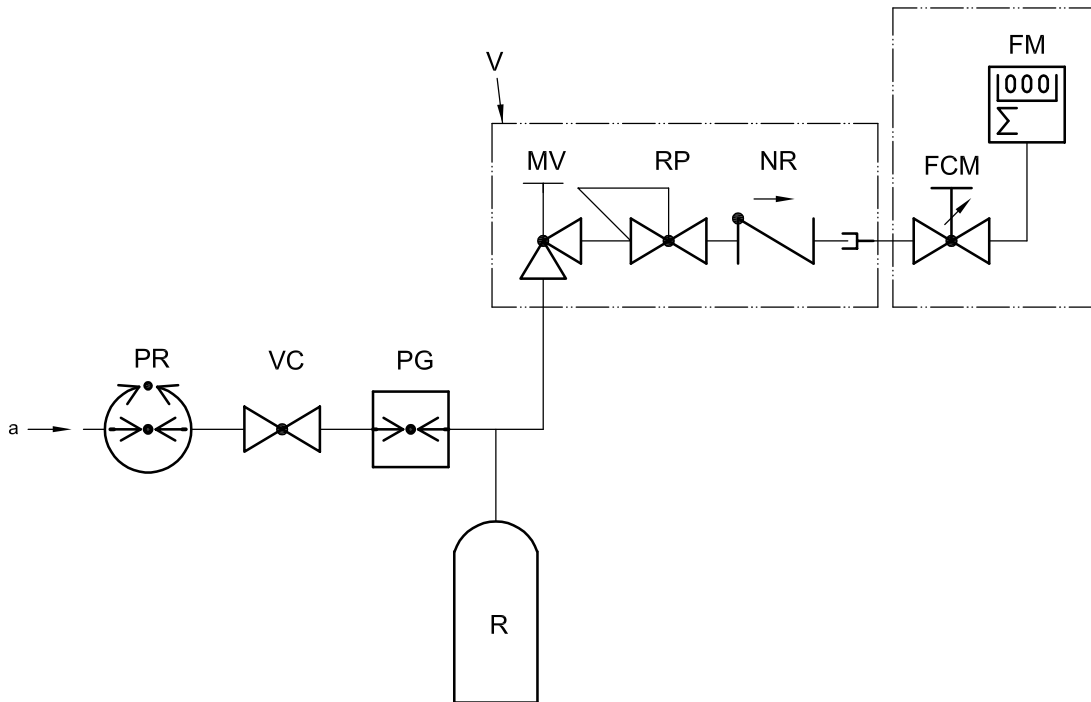

Key

- PR pressure reducer
- VC control valve
- PG pressure gauge
- R reservoir
- MV main valve
- RP residual pressure device
- NR non-return valve
- V valve
- FCM flow control meter
- FM flowmeter
- a Gas in.

Figure B.2

Annex C (informative)

Conveyance test

The residual pressure function of the valve should minimize gas leakage due to vibration experienced in transport.

The following test is intended to reproduce the vibration during transportation.

A minimum of 3 samples is required (1 per type variant).

The residual pressure valve shall be connected to a 5 l gas cylinder mounted on a vibration apparatus. The test shall be carried out with an initial pressure of 0,5 bar in the gas cylinder and with the main valve orifice open. After being subjected to vibration along the axis of the residual pressure device and in accordance with the procedure given below, the cylinder pressure shall be greater \geq 0,25 bar.

- 1) Resonance test run before testing
 - sine wave run, one sweep from 5 Hz to 1 000 Hz with an acceleration of 0,5 *g*.
- 2) Sine wave test. 300 Hz to 1 000 Hz with an acceleration of 2,0 *g*.
 - duration of test 10 min.
- 3) Repeat test 1 above.
- 4) Random vibration.
 - 10 Hz to 1 000 Hz, 8,181 *g*.
- 5) Repeat test 1 above.

Annex D (informative)

Integrity under high flow

A minimum of 5 samples is required (minimum of 2 per variant).

The residual pressure valve is connected to a cylinder with a volume of 20 l water capacity. For the test, air or nitrogen is used. The flow test is carried out on the residual pressure valve in the flowing and filling directions, the main valve orifice should be fully open.

NOTE 1 For valves used for nitrous oxide, carbon dioxide or carbon dioxide mixtures, these tests are repeated using liquid carbon dioxide.

NOTE 2 The following tests can create an oxygen deficient atmosphere. Suitable precautions should be taken to avoid risk of asphyxiation to personnel:

- flow direction: a cylinder with a minimum volume of 20 l water capacity filled via inlet 1 to p_w for compressed gases or to the correct filling ratio for carbon dioxide (and with a minimum pressure of 40 bar at the start of the test) should have its contents discharged safely to the atmosphere through the residual pressure valve and outlet 2 in the flow direction 10 times. The valve should be in the fully open condition and with the outlet unobstructed (see Figure D.1);
- filling direction: a cylinder with a minimum volume of 20 l water capacity filled via inlet 1 to p_w or to the correct filling ratio for carbon dioxide (and with a minimum pressure of 40 bar at the start of the test) should have its contents discharged safely to the atmosphere through the residual pressure valve and outlet 2 in the filling direction 10 times. Any residual pressure valve device should be neutralized (see Figure D.2).

Residual pressure valves should be able to withstand the gas dynamic and thermal loads created during cylinder filling and venting.

NOTE 3 If the valve is to be used in liquefied gas service, this test should ensure liquefied gas is passed through the test valve.

At the conclusion of the tests the residual pressure valves should operate correctly to specification.

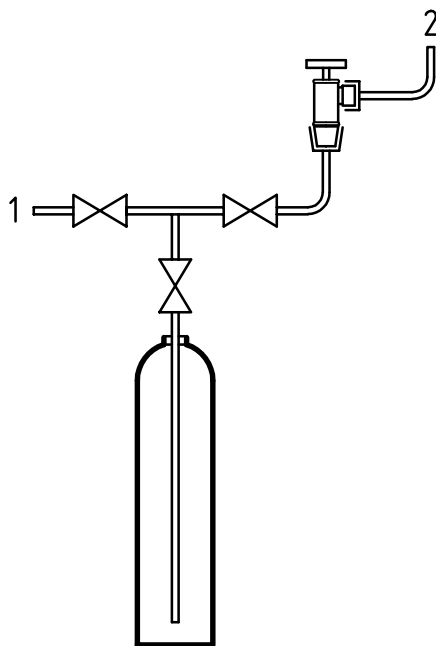

Key

- 1 inlet
- 2 outlet

Figure D.1 — Flow direction test

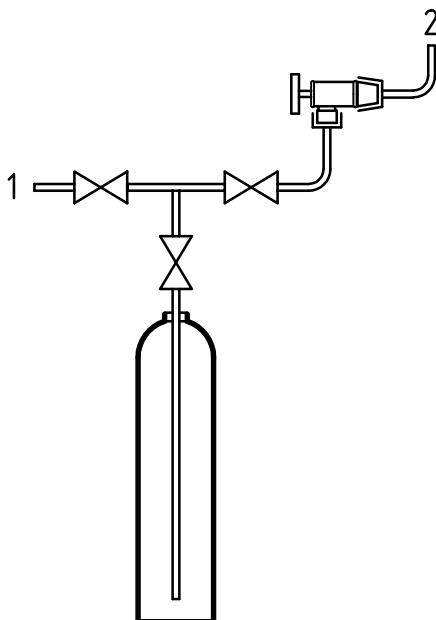

Key

- 1 inlet
- 2 outlet

Figure D.2 — Filling direction test

Bibliography

- [1] ISO 188, *Rubber, vulcanized or thermoplastic — Accelerated ageing and heat resistance tests*
- [2] ISO 1817, *Rubber, vulcanized — Determination of the effect of liquids*
- [3] ISO 5145, *Cylinder valve outlets for gases and gas mixtures — Selection and dimensioning*
- [4] ISO/TR 7470, *Valve outlets for gas cylinders — List of provisions which are either standardized or in use*
- [5] ISO 10286, *Gas cylinders — Terminology*
- [6] ISO 11114-2, *Transportable gas cylinders — Compatibility of cylinder and valve materials with gas contents — Part 2: Non-metallic materials*

Vertical line of small characters or a barcode-like artifact.

ICS 23.020.30

Price based on 15 pages