

INTERNATIONAL
STANDARD

ISO
15872

Second edition
2017-03

Aerospace — UNJ threads — Gauging

Aéronautique et espace — Filetage UNJ — Vérification par calibres



Reference number
ISO 15872:2017(E)

© ISO 2017



COPYRIGHT PROTECTED DOCUMENT

© ISO 2017, Published in Switzerland

All rights reserved. Unless otherwise specified, no part of this publication may be reproduced or utilized otherwise in any form or by any means, electronic or mechanical, including photocopying, or posting on the internet or an intranet, without prior written permission. Permission can be requested from either ISO at the address below or ISO's member body in the country of the requester.

ISO copyright office
Ch. de Blandonnet 8 • CP 401
CH-1214 Vernier, Geneva, Switzerland
Tel. +41 22 749 01 11
Fax +41 22 749 09 47
copyright@iso.org
www.iso.org

Contents

Page

Foreword	iv
1 Scope	1
2 Normative references	1
3 Terms, definitions, symbols and abbreviated terms	1
3.1 Terms and definitions.....	1
3.2 Symbols and abbreviated terms.....	2
4 Types of gauges	3
4.1 Gauges and setting plugs for external threaded products.....	3
4.2 Gauges for internal threaded products.....	3
5 Reference temperature	3
6 Function, design and use of gauges	4
6.1 Gauges for external threads.....	4
6.1.1 Virtual pitch diameter indicating thread gauges.....	4
6.1.2 Solid or adjustable GO screw ring gauges.....	4
6.1.3 Simple pitch diameter indicating thread gauges.....	4
6.1.4 Major diameter gauges.....	5
6.1.5 Minor diameter gauges.....	5
6.1.6 Optical comparator checks.....	5
6.2 Gauging for internal threads.....	5
6.2.1 GO screw plug gauges.....	5
6.2.2 NOT GO screw plug gauges.....	5
6.2.3 Minor diameter gauges.....	5
6.2.4 Virtual pitch diameter indicating thread gauges.....	5
6.2.5 Simple pitch diameter indicating thread gauges.....	6
7 Setting of gauges	6
7.1 Setting gauges for external threads.....	6
7.2 Setting ring gauge for indication thread gauges.....	6
8 Gauging of threads	6
8.1 General.....	6
8.2 Internal threads evaluation.....	7
Bibliography	22

Foreword

ISO (the International Organization for Standardization) is a worldwide federation of national standards bodies (ISO member bodies). The work of preparing International Standards is normally carried out through ISO technical committees. Each member body interested in a subject for which a technical committee has been established has the right to be represented on that committee. International organizations, governmental and non-governmental, in liaison with ISO, also take part in the work. ISO collaborates closely with the International Electrotechnical Commission (IEC) on all matters of electrotechnical standardization.

The procedures used to develop this document and those intended for its further maintenance are described in the ISO/IEC Directives, Part 1. In particular the different approval criteria needed for the different types of ISO documents should be noted. This document was drafted in accordance with the editorial rules of the ISO/IEC Directives, Part 2 (see www.iso.org/directives).

Attention is drawn to the possibility that some of the elements of this document may be the subject of patent rights. ISO shall not be held responsible for identifying any or all such patent rights. Details of any patent rights identified during the development of the document will be in the Introduction and/or on the ISO list of patent declarations received (see www.iso.org/patents).

Any trade name used in this document is information given for the convenience of users and does not constitute an endorsement.

For an explanation on the voluntary nature of standards, the meaning of ISO specific terms and expressions related to conformity assessment, as well as information about ISO's adherence to the World Trade Organization (WTO) principles in the Technical Barriers to Trade (TBT) see the following URL: www.iso.org/iso/foreword.html.

This document was prepared by ISO/TC 20, *Aircraft and space vehicles*, Subcommittee SC 4, *Aerospace fastener systems*.

This second edition cancels and replaces the first edition (ISO 15872:2002), which has been technically revised and includes the following changes:

- unused symbols have been removed from [Table 1](#): WGO, WNG, Z1, ZPL, and ZR.
- Figures have been changed to align with [8.1](#).
- Normative references have been updated.
- Terminology has been updated.
- The document has been editorially revised.

Aerospace — UNJ threads — Gauging

1 Scope

This document provides methods for the gauging of ISO UNJ threads complying with ISO 3161.

Other methods of ensuring that the product is within the specified limits can be used, provided that correlation with the specified gauges is established.

2 Normative references

The following documents are referred to in the text in such a way that some or all of their content constitutes requirements of this document. For dated references, only the edition cited applies. For undated references, the latest edition of the referenced document (including any amendments) applies.

ISO 1, *Geometrical product specifications (GPS) — Standard reference temperature for the specification of geometrical and dimensional properties*

ISO 3161, *Aerospace — UNJ threads — General requirements and limit dimensions*

3 Terms, definitions, symbols and abbreviated terms

3.1 Terms and definitions

For the purposes of this document, the terms and definitions given in ISO 5408 and the following apply.

ISO and IEC maintain terminological databases for use in standardization at the following addresses:

- IEC Electropedia: available at <http://www.electropedia.org/>
- ISO Online browsing platform: available at <http://www.iso.org/obp>

3.1.1

best wire size

cylinder or sphere which has a radius so that it will contact the thread flanks at the pitch cylinder intersection

Note 1 to entry: The radius of the best wire or sphere is theoretically equal to $0,288\ 68P$.

3.1.2

indicating gauge

device having contacts which will precisely compare the size of a work piece thread to a setting standard of known dimensions

Note 1 to entry: The value for the indicated characteristic thus established is the dimensional value attributed to the work piece. An indicating gauge can have contacts designed to measure any thread characteristic. This document specifies the characteristics and designs for ISO UNJ threads.

3.1.3

simple pitch diameter

diameter of an imaginary cylinder intersecting an actual thread over the width of one groove where that width is equal to one half of the basic pitch

3.1.4

virtual pitch diameter

pitch diameter of the smallest (for external threads) or largest (for internal threads) perfect thread form with GO gauge profile which can engage the product threads for a distance equal to the GO gauge thread engagement

3.2 Symbols and abbreviated terms

See [Table 1](#).

Table 1 — Symbols, abbreviated terms and definitions

Symbol or abbreviated term	Definition	Symbol or abbreviated term	Definition
D_1	Basic minor diameter of the internal thread of a workpiece	$T_{\alpha 1/2}$	Tolerance for each flank angle of a profile with complete flanks
d_2	Basic pitch diameter of the external thread of a workpiece	$T_{\alpha 2/2}$	Tolerance for each flank angle of a profile with truncated flanks
es	Fundamental deviation of the external thread of a workpiece	T_{CP}	Tolerance on the pitch diameter of GO and NOT GO screw check plugs, wear check plugs and setting plugs
EI	Fundamental deviation of the internal thread of a workpiece	T_d	Tolerance for the major diameter of the external thread of a workpiece
H	Height of the triangle of a thread profile	T_{d2}	Tolerance for the pitch diameter of the external thread of a workpiece
H_1	Tolerance for the diameter of plain plug gauges	T_{d3}	Tolerance for the minor diameter of the external thread of a workpiece
H_P	Tolerance on the size of check plug gauges for plain calliper gauges	T_{D1}	Tolerance for the minor diameter of the internal thread of a workpiece
(LSL)	Lower specification limit	T_P	Pitch tolerance
m	Distance between the middle of the tolerance zones TR of a screw ring gauge and TCP of a GO check plug	T_{D2}	Tolerance for the pitch diameter of the internal thread of a workpiece
(USL)	Upper specification limit	T_{PL}	Tolerance for the pitch diameter of GO and NOT GO screw plug gauges
P	Pitch	T_R	Tolerance for the pitch diameter of GO and NOT GO screw ring gauges

4 Types of gauges

4.1 Gauges and setting plugs for external threaded products

The function, design and use of gauges and setting plugs for external threads are explained in the following subclauses.

Gauge type	Subclause
a) GO screw ring gauges	6.1.2
b) Setting plug for adjustable GO screw ring and indicating thread gauges	7.1.1
c) Virtual pitch diameter indicating thread gauges	6.1.1
d) Simple pitch diameter indicating thread gauges	6.1.3
e) Flat contact gauges for major diameter	6.1.4
f) Point contact indicating thread gauges for minor diameter	6.1.5
g) Optical comparator for root radius and minor diameter	6.1.6

4.2 Gauges for internal threaded products

The function, design and use of gauges for internal threads are explained in the following subclauses.

Gauge type	Subclause
a) GO screw plug gauges	6.2.1
b) NOT GO screw plug gauges	6.2.2
c) Plain gauges for minor diameter (plug gauge)	6.2.3.1
d) GO full form screw plug gauges	6.2.3.2
e) Virtual pitch diameter indicating thread gauges	6.2.4
f) Simple pitch diameter indicating thread gauges	6.2.5
g) Setting ring gauge for indicating thread gauges (solid type)	7.2

5 Reference temperature

In accordance with ISO 1, the dimensions of the gauge and the product shall be checked at the temperature of 20 °C.

If the product and the gauge have the same coefficients of linear expansion, the temperature may deviate from 20 °C, provided the temperature of the product and the gauge are the same.

If the product and the gauge have different coefficients of linear expansion, the temperature of both, at the time of gauging, shall be:

- a) 20 °C ± 2 °C for sizes 1,000 UNJ and smaller;
- b) 20 °C ± 1 °C for larger threads.

6 Function, design and use of gauges

6.1 Gauges for external threads

6.1.1 Virtual pitch diameter indicating thread gauges

6.1.1.1 It measures, on two or three segments or rolls, the maximum material virtual pitch diameter taking into account variations of form such as pitch variation, helix and flank variations, roundness and taper which produces an enlargement of the virtual pitch diameter. In addition, virtual pitch diameter control ensures the flank angle contact is sufficient to ensure that the root radius does not exceed the maximum limit. Measurement of virtual pitch diameter with indicating gauges shall be obtained to calculate virtual minus simple pitch diameter differential unless the simple pitch diameter limits, gauged in accordance with [6.1.3](#), are within the limits defined by the maximum pitch diameter and the form variation limits in ISO 3161.

6.1.1.2 Indicating gauges have two or three contacts at 180° or 120°, respectively. Gauges with segments or rolls are designed with the length of the GO virtual maximum material gauging elements equal to the GO ring gauge length equal to nine pitches (P) or the basic major diameter of the thread, whichever is the smallest. For configuration and profile requirements, see [Figure 1](#).

6.1.1.3 The minor diameter of the GO virtual maximum material thread segments and the diameter of the circle surrounded by the roll cluster of GO virtual maximum material rolls shall be equal to the pitch diameter of the product minus $0,375H$, less the T_{PL} value in [Table 2](#) minus tolerance when assembled in the gauge frame. This corresponds to a flat width of $0,3125P$ on the minor crest for the thread. The crest shall be flat in an axial plane and parallel to the axis of the segments or rolls.

6.1.1.4 The major diameter of the GO virtual maximum material segments and the root of the GO virtual maximum material rolls shall be cleared beyond a $0,125P$ flat either by an extension of the flanks of the thread toward a sharp vee or by an undercut no greater than $0,125P$ maximum width and approximately central. The root clearance shall be such that the major diameter of the full form section of the thread setting plug gauge is cleared after the assembled gauge has been properly set to size.

6.1.1.5 The pitch diameter cylinder axis of threaded segments and rolls shall be straight within the diameter tolerance zone equal to T_{PL} specified in [Table 2](#). The half-angle variations in the segment or roll thread shall be within the limits specified in [Table 3](#). For the pitch variations, see [Table 4](#).

6.1.2 Solid or adjustable GO screw ring gauges

To ensure the ease of assembly of product threads and conformance to the maximum material virtual pitch diameter limits, solid or adjustable, GO screw ring gauges with thread form in accordance with [Figure 1](#) and setting gauges in accordance with [7.1.1](#) may be used. Solid GO screw ring gauges shall not be permitted to exceed the product thread dimensional limits. The gauge thickness/length shall be standardized (see [6.1.1.2](#)). Details on adjustable GO thread ring gauges and truncated setting plugs may be obtained from ASME B1.2.

6.1.3 Simple pitch diameter indicating thread gauges

The simple pitch diameter indicating gauge with cone and vee rolls or segments or rolls with best wire size radius is applied to ensure that the pitch diameter is greater than the minimum limit. The indicators are set to the GO threaded setting plug gauge. Readings indicate the position of the pitch diameter and the minimum measurement shall be no less than the minimum pitch diameter limit. The minimum measured pitch diameter shall be within the ISO 3161 form variation limit compared to the virtual pitch diameter measurement in accordance with [6.1.1](#), i.e. the differential value.

The simple pitch diameter contacts have cone and vee rolls or segments which contact the product pitch cylinder. Other designs have two or three rolls with radii on annular ribs on rolls made to best

wire size. The product thread contacts are restricted to 1,5 pitch lengths. See [Figure 2](#) and [Figure 3](#) for design and contact form.

6.1.4 Major diameter gauges

The maximum limit of the major diameter may be checked with a plain ring gauge, a plain GO calliper, or plain diameter-measuring device; see [Figure 4](#). The minimum limit of the major diameter shall be checked with a plain diameter measuring device set to a plain diameter plug with H_P tolerance (see [Table 5](#)). A plain micrometer calliper may be used to measure the major diameter and may have standard gauge block settings.

6.1.5 Minor diameter gauges

It shall be set to the plain minor diameter setting plug with H_P tolerance (see [Table 5](#)). See [Figure 5](#) for design and contact form.

6.1.6 Optical comparator checks

The optical comparator shall be used to verify the root radius by comparing the shadow contour to the radius charts. The minor diameter may also be measured with an optical comparator using appropriate measuring techniques.

6.2 Gauging for internal threads

6.2.1 GO screw plug gauges

To ensure the ease of assembly of threads and conformance to the maximum material virtual pitch and major diameter limits, GO screw plug gauges or the full form GO screw plug gauge in accordance with [6.2.3.2](#) shall be used. For gauge tolerances, see [Table 2](#) to [Table 4](#).

6.2.2 NOT GO screw plug gauges

To check that the simple pitch diameter is not greater than the maximum limit, NOT GO screw plug gauges shall be used. For gauge tolerances, see [Table 2](#) to [Table 4](#).

6.2.3 Minor diameter gauges

6.2.3.1 The minimum minor diameter may be evaluated by a plain cylindrical GO plug gauge or a GO full form screw plug gauge in accordance with [6.2.3.2](#). The maximum minor diameter may be checked with a plain cylindrical NOT GO plug gauge. The diameters of the plain plugs shall be based on the minimum minor diameter specified in ISO 3161 with gauge tolerance H_1 specified in [Table 7](#). Internal micrometer callipers may be used to measure the minor diameter.

6.2.3.2 The GO full form screw plug gauge shall be a modified GO screw plug gauge with a controlled root radius on the gauge (see [Figure 6](#)) equal to the maximum external thread root radius specified in ISO 3161 with a radius tolerance in accordance with [Table 8](#).

6.2.4 Virtual pitch diameter indicating thread gauges

6.2.4.1 It measures, on two or three segments or rolls, the maximum material virtual pitch diameter taking into account variations of form such as pitch variation, helix and flank variations, roundness and taper which produces a decrease in the virtual pitch diameter. The virtual pitch diameter shall be measured using indicating gauges to calculate the simple minus virtual pitch diameter differential unless the simple pitch diameter limits are within the limits defined by the minimum pitch diameter and the form variation limits in ISO 3161.

6.2.4.2 Indicating gauges have two or three contacts at 180° or 120°, respectively. Gauges with segments or rolls are designed with the length of the GO virtual maximum material gauging elements equal to the GO plug gauge length equal to nine pitches (P) or the basic major diameter of the thread, whichever is the smallest. For configuration and profile requirements, see [Figure 7](#).

6.2.5 Simple pitch diameter indicating thread gauges

The simple pitch diameter indicating thread gauge with cone and vee rolls or segments or rolls with the best wire size radius is applied to ensure that the pitch diameter is not greater than the maximum limit. The indicators are set to the GO threaded ring gauge. Readings indicate the position of the pitch diameter and the maximum measurement shall be not greater than the maximum pitch diameter limit. The maximum measured pitch diameter shall be within the ISO 3161 form variation limit compared to the virtual pitch diameter measurement made in accordance with [6.2.4.1](#).

The simple pitch diameter contacts have cone and vee rolls or segments which contact the product pitch cylinder. Other designs have two or three rolls with radii on annular ribs on rolls made to best wire size. The product thread contacts are restricted to 1,5 pitch lengths. See [Figure 8](#) and [Figure 9](#) for design and contact form for simple pitch diameter indicating thread gauges.

7 Setting of gauges

7.1 Setting gauges for external threads

7.1.1 The virtual pitch diameter indicating gauge is set to the threaded setting plug whose average simple pitch diameter (see [Figure 10](#)) is equal to basic size. Set and check the GO screw ring gauge as required. Check the GO screw plug gauge as required.

7.1.2 Set the simple pitch diameter indicating gauge to the calibrated or marked pitch diameter setting plug gauge. These gauges are the same setting gauges as described in [7.1](#) to permit differential measurement calculations.

7.1.3 Set the major and minor diameter indicating gauges to their respective plain setting plugs. The diameter of these plain setting plugs shall be made to the maximum dimension with a negative tolerance of H_p (see [Table 6](#), [Figure 11](#) and [Figure 12](#)). The micrometer callipers may have standard gauge block settings.

7.2 Setting ring gauge for indication thread gauges

The virtual pitch diameter indicating thread gauge and the simple pitch diameter indicating thread gauge to measure internal threads is set with the solid GO screw ring gauge.

8 Gauging of threads

8.1 General

Gauges with a wear allowance, which allows gauges to exceed the maximum or minimum limits of the product thread, are not permitted for UNJ threads.

A product thread characteristic is acceptable when any appropriate standardized gauge can be assembled. The manufacturer is responsible for ensuring that, whatever the case, the means ultimately ensures characteristics in accordance with the envelope requirements.

External threads shall be evaluated as follows.

- a) Check the virtual pitch diameter by measurement using either an indicating gauge or an assembly with a GO threaded ring gauge.

- b) Measure the simple pitch diameter with an indicating gauge.
- c) Compare the difference between the virtual and simple pitch diameter measurements to evaluate the cumulative effect of variations defined in ISO 3161.
- d) Check thread minor and major diameters with indicating gauge and root contour with an optical comparator or tracing machine.
- e) Normally, the use of more than one gauge option is not required. A product thread characteristic is accepted if it satisfies any one appropriate standard gauge. However, if there is a conflict between gauges for the product external thread maximum material limit, the product thread shall be accepted as long as the thread satisfies the GO thread ring gauge.

8.2 Internal threads evaluation

- Check the maximum material limit of the virtual pitch diameter as well as the minimum major diameter with a GO screw plug gauge. A full form screw plug gauge may be used for this check. A check for the virtual pitch diameter by measurement with an indicating thread gauge may be used also.
- Check the minimum material pitch diameter with a NOT GO screw plug gauge. Measuring the simple pitch diameter with an indicating thread gauge is (except for thread sizes less than 0.190 in) required.
- Check the minimum minor diameter with either a GO plain plug gauge or GO full form screw plug gauge. Use a NOT GO plain plug gauge to check the maximum minor diameter.

Table 2 — Tolerances for pitch diameter of GO and NOT GO screw plug gauges and on pitch diameter of GO and NOT GO screw check plugs, and setting plugs

Tolerances in inches

T_{d2} or T_{D2}		T_{CP}^a	T_{PL}
over	up to and including		
—	0.002	0.000 2	0.000 2
0.002	0.003		
0.003	0.006	0.000 3	0.000 3
0.006	0.008	0.000 35	0.000 4
0.008	0.012	0.000 47	0.000 5
0.012	0.020	0.000 6	0.000 7
0.020	0.026	0.000 7	0.000 9

^a See [Figure 10](#).

Table 3 — Tolerances for each half-angle

Tolerances in minutes of an angle

Number of threads per inch	Pitch P in	$T_{\alpha 1}/2^a$	$T_{\alpha 2}/2^a$
80	0.012 500	±60	
72	0.013 889	±48	
64	0.015 625	±40	
56	0.017 857	±35	
48	0.020 833	±31	
44	0.022 727	±26	
40	0.025 000	±25	
36	0.027 778	±21	
32	0.031 250	±18	
28	0.035 714	±17	±17
24	0.041 667	±16	±16
20	0.050 000	±15	
18	0.055 556	±13	±16
16	0.062 500	±12	
14	0.071 429	±11	
13	0.076 923	±10	±14
12	0.083 333		
11	0.090 909	±9	±13
10	0.100 000		±12
9	0.111 111	±8	±11
8	0.125 000		
7	0.142 857		
6	0.166 667		±10
5	0.200 000		
4,5	0.222 222		
4	0.250 000		

^a See [Figure 13](#).

Table 4 — Pitch tolerances

Values in inches

Thread length		
≤ 1.250	> 1.250 ≤ 2.000	> 2.000 ≤ 3.150
T_P		
0.000 2	0.000 24	0.000 28
<p>NOTE The pitch tolerance, T_P, applies to the maximum measured error whether it occurs as a cumulative progressive error over the total length of thread or as a periodic error or as a local error of pitch.</p> <p>For a double-length setting plug, the thread length used when determining the pitch deviation is one-half of the overall thread length of the setting plug, and the pitch tolerance is the maximum permissible deviation between any two threads spaced apart by not more than one half the overall length of the setting plug.</p>		

Table 5 — Tolerances for plain setting plug for major and minor diameters of external threads

Tolerances in inches

T_d		Tolerance
over	up to and including	H_p^a
—	0.003	0.000 08
0.003	0.005	0.000 1
0.005	0.013	0.000 15
0.013	0.033	0.000 24
0.033	0.037	0.000 31
<p>^a See Figure 11 and Figure 12.</p>		

Table 6 — Tolerances for plain plug for minor diameters of internal threads

Tolerances in inches

T_{D1}		Tolerance
over	up to and including	H_1
—	0.004	0.000 15
0.004	0.007	0.000 2
0.007	0.015	0.000 3
0.015	0.028	0.000 5
0.028	0.050	0.000 9

Table 7 — Controlled root radius tolerances for GO full form screw plug gauges

Tolerances in inches

Threads per inch	Radius tolerance	Threads per inch	Radius tolerance
80	0.000 21	36	0.000 51
72	0.000 24	32	0.000 55
64	0.000 28	28	0.000 71
56	0.000 31	24	
48	0.000 35	20	0.000 9
44	0.000 43	18 to 10	0.001
40	0.000 51	9 to 4	0.002

Table 8 — Factor m for setting gauges

Values in inches

T_{d2}		m^a
over	up to and including	
—	0.002	0.004
0.002	0.003	0.005
0.003	0.005	0.006
0.005	0.008	0.007
0.008	0.012	0.008
0.012	0.020	0.010
0.020	0.026	0.013
^a See Figure 10 .		

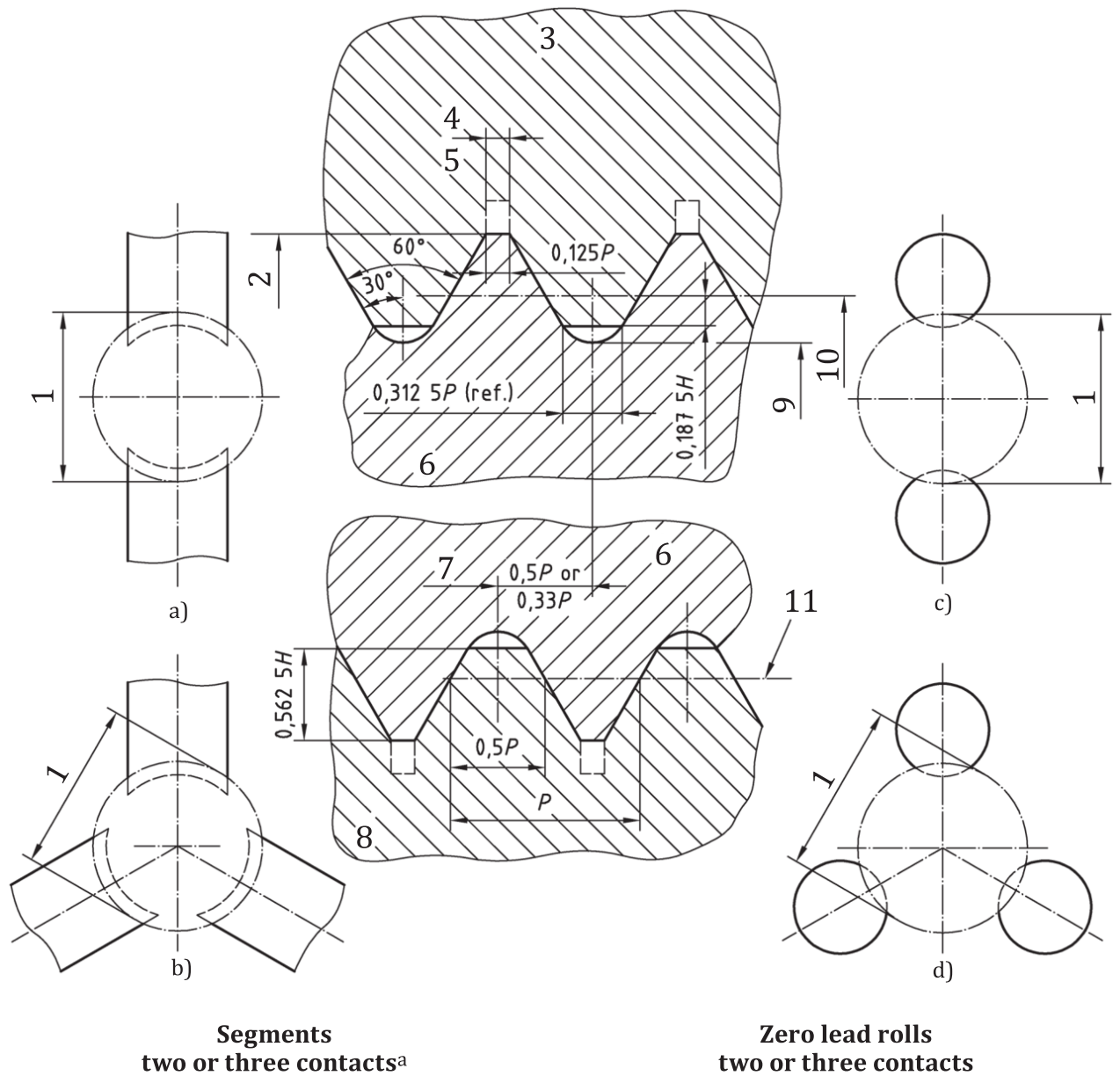

Key

- | | | | |
|---|---|----|---|
| 1 | pitch diameter | 7 | for two or three contacts respectively |
| 2 | maximum major diameter of product external thread | 8 | form of segment or roll |
| 3 | gauge thread form | 9 | maximum minor diameter of product external thread |
| 4 | clear $0,125P$ when not undercut | 10 | maximum pitch diameter of product external thread |
| 5 | form of relief optional — width approximately central when undercut | 11 | pitch cylinder |
| 6 | maximum product external thread | | |

^a The total segment contact to be a minimum of 25 % of circumference.

Figure 1 — Virtual pitch diameter indicating thread gauges for external threads

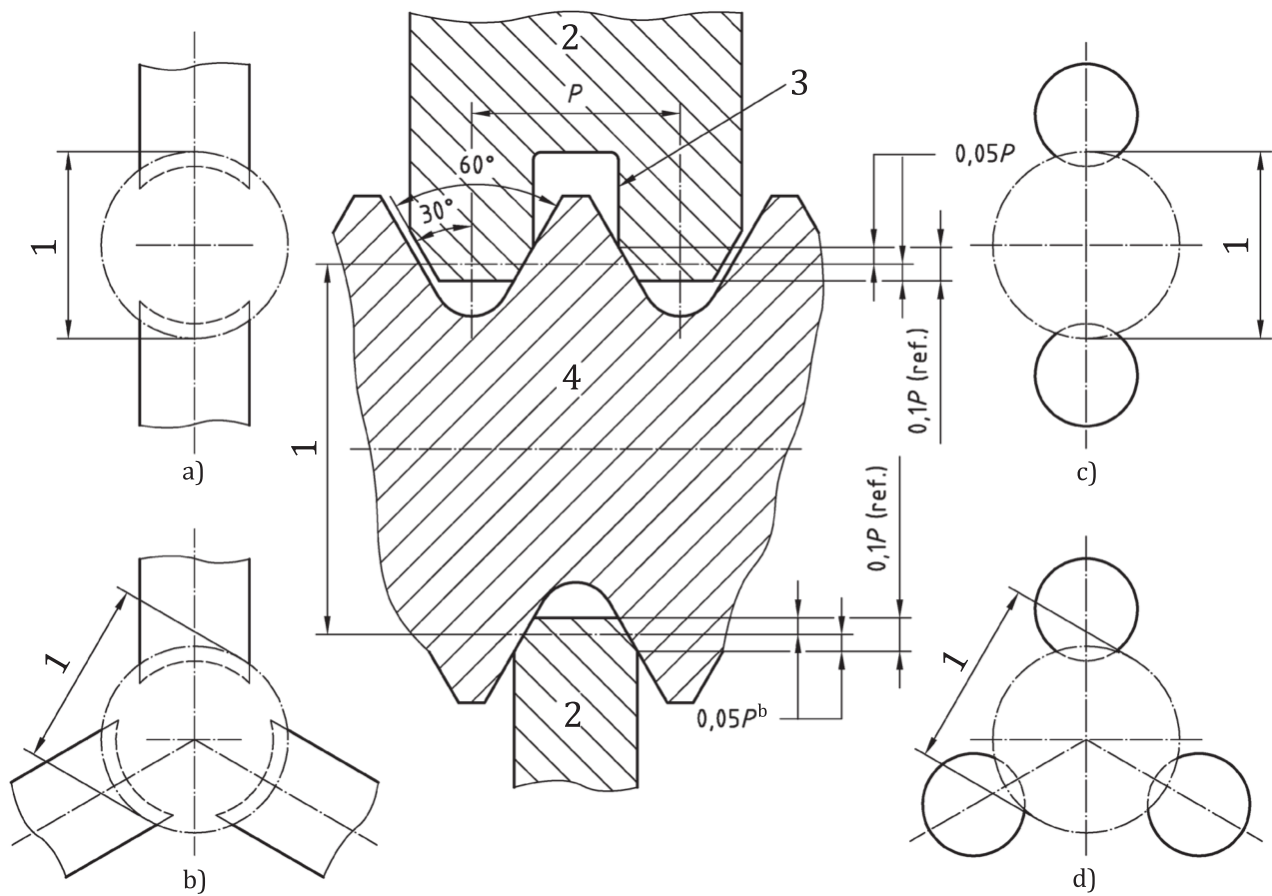

**Segments
two or three contacts^a**

**Zero lead rolls
two or three contacts**

Key

- 1 pitch diameter
- 2 gauging element
- 3 form of relief optional
- 4 external thread

^a The total segment contact to be a minimum of 25 % of circumference.

^b Contact central on pitch line.

Figure 2 — Simple pitch diameter indicating thread gauges with cone and vee for external threads

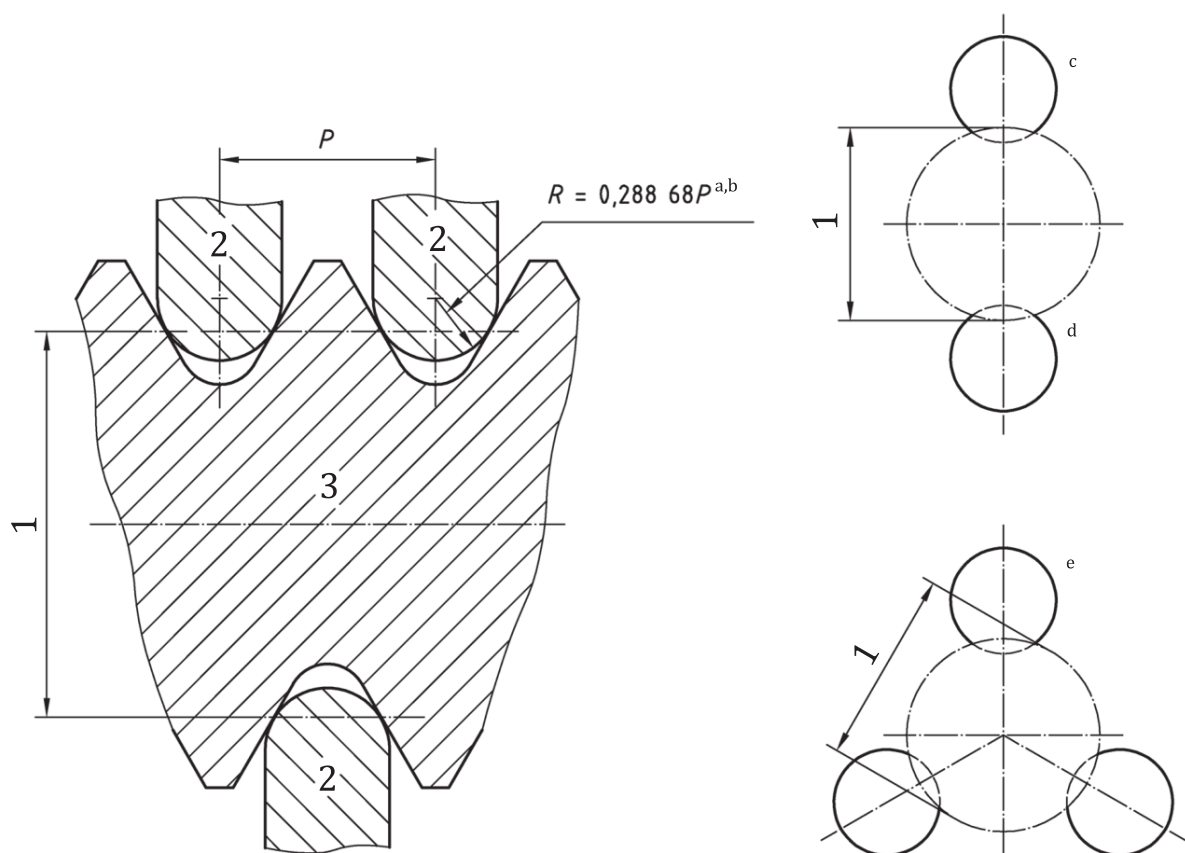

**Rolls
three or two contacts**

Key

- 1 pitch diameter
- 2 roll
- 3 external thread
- a Rolls — Gauging contacts.
- b Best wire size radius.
- c Two ribs on top roll.
- d One rib on bottom roll.
- e One rib on each roll, one-third pitch apart.

Figure 3 — Simple pitch diameter indicating thread gauges with radius roll for external threads

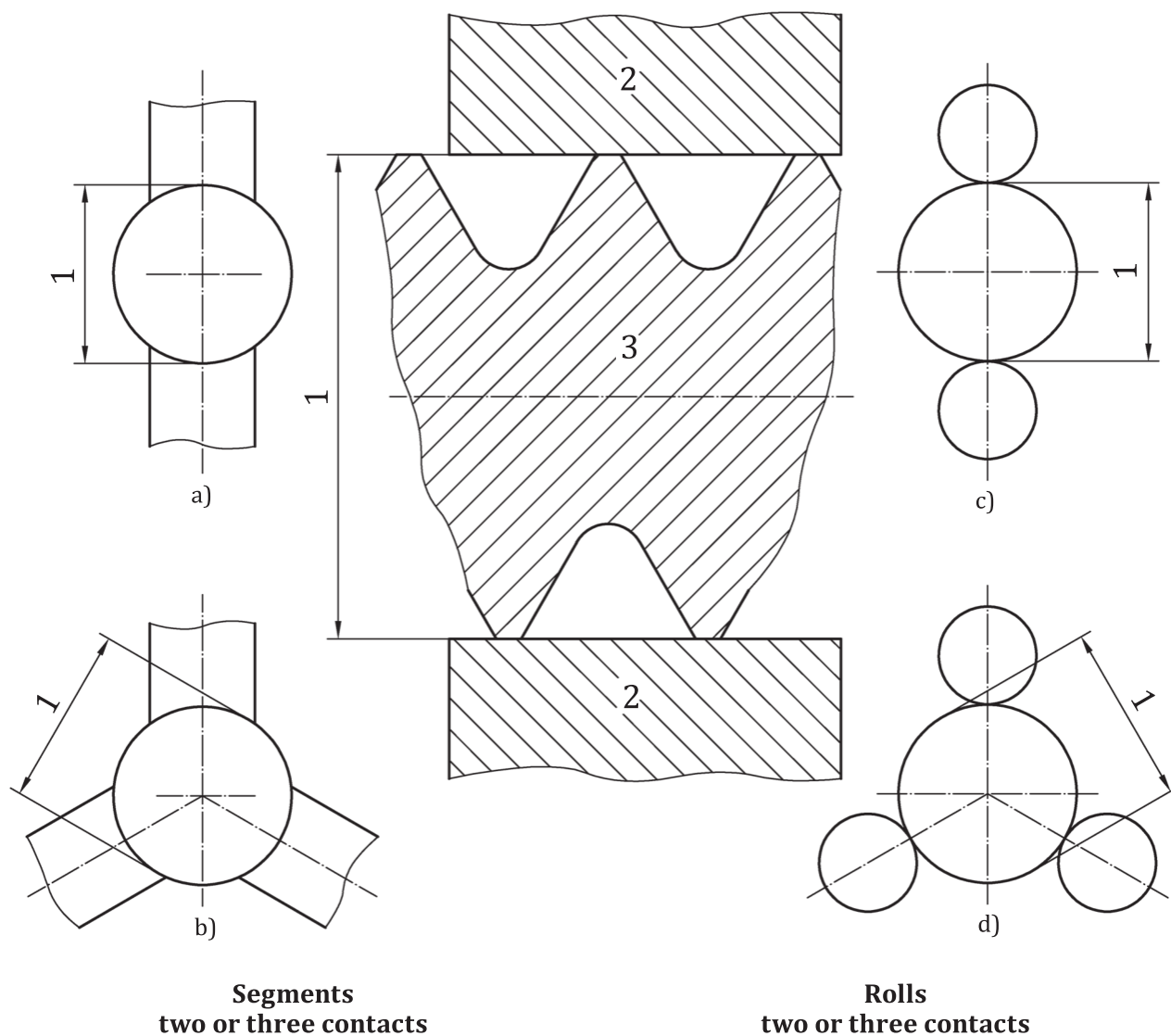

Key

- 1 major diameter
- 2 plain gauge contact
- 3 external thread

Figure 4 — Major diameter indicating plain gauges for external threads

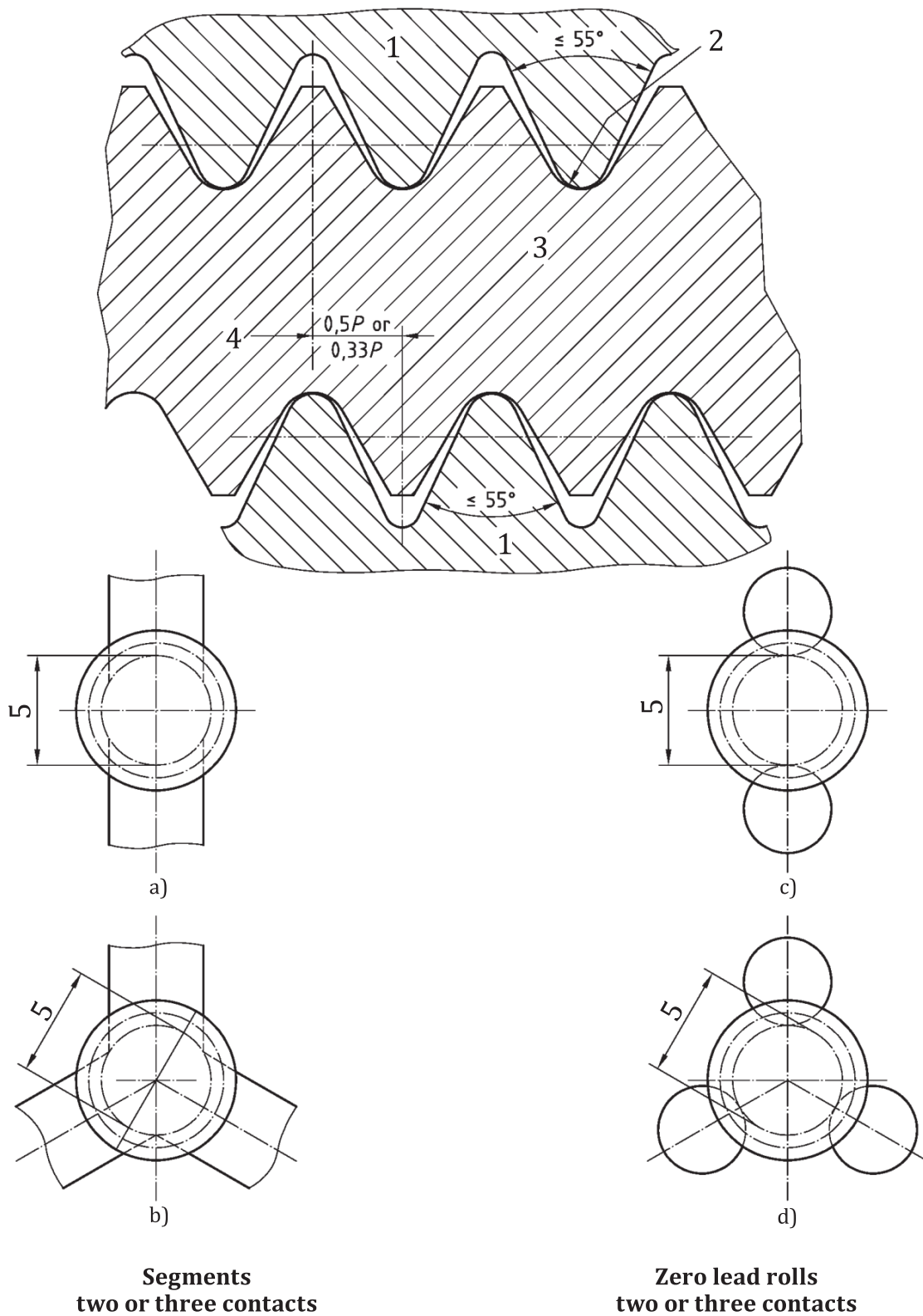

Key

- | | | | |
|---|--|---|--|
| 1 | three thread segments or rolls | 4 | for two or three contacts respectively |
| 2 | radius not to exceed root radius of part | 5 | minor diameter |
| 3 | external thread | | |

Figure 5 — Minor diameter indicating thread gauges for external threads

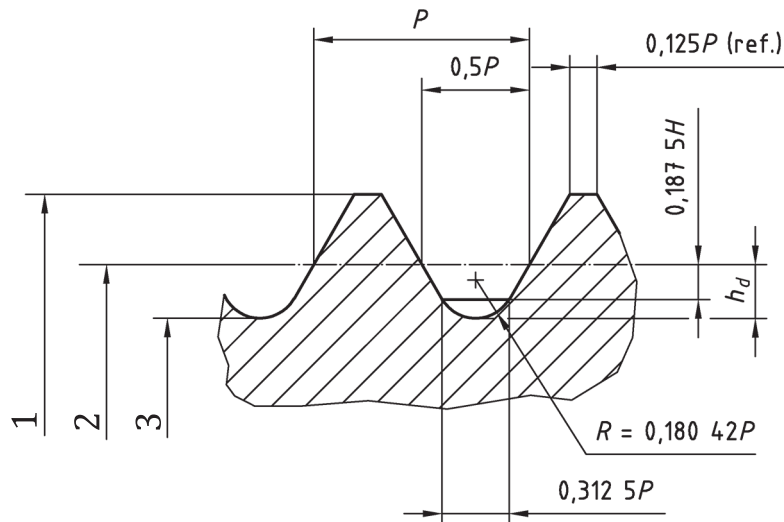

Key

- 1 major diameter
- 2 pitch diameter
- 3 minor diameter

Figure 6 — GO full form screw plug gauges for maximum material, internal threads

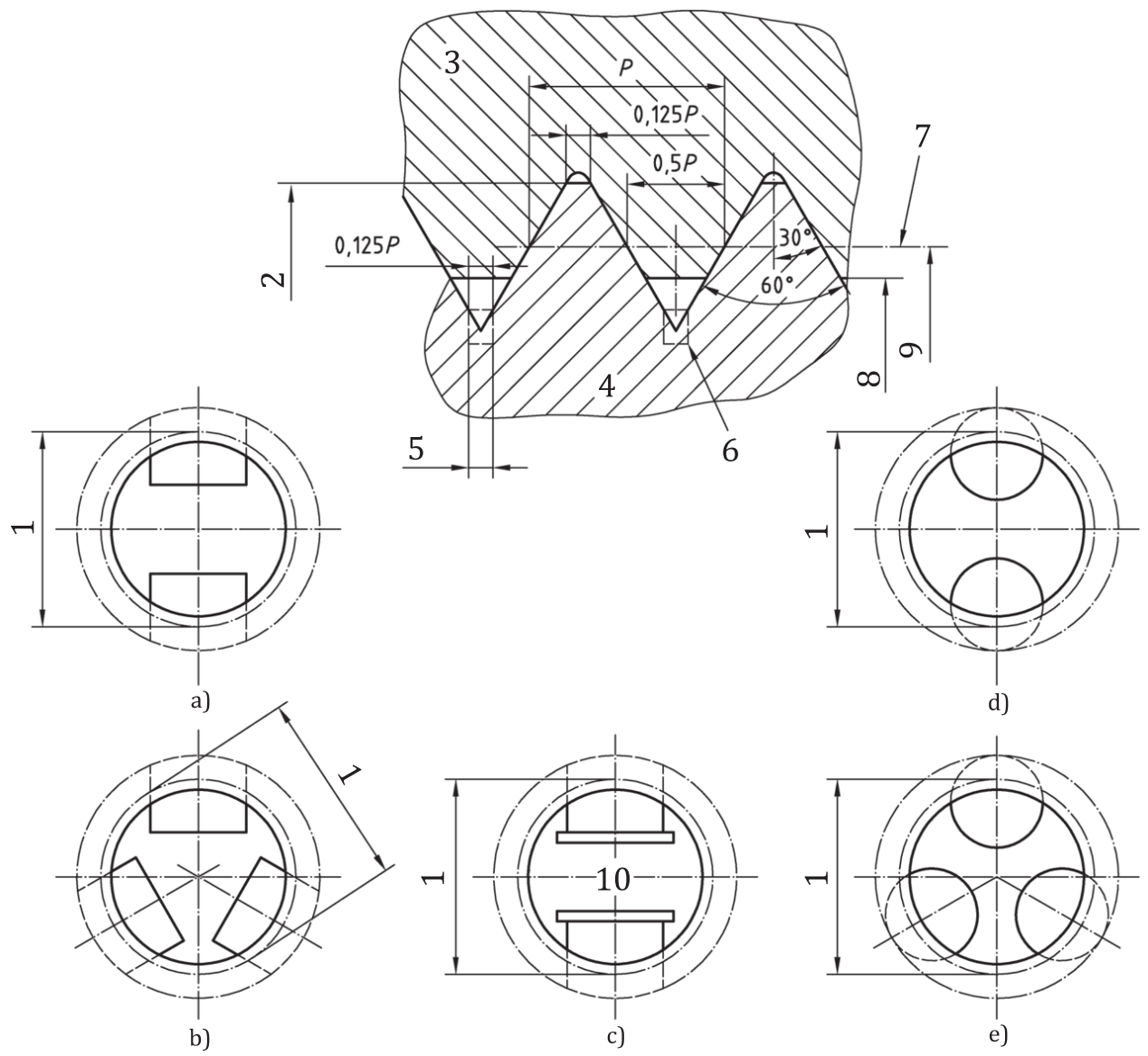

**GO threaded segments
two or three contacts^a**

Threaded contacts

**GO zero lead rolls
two or three contacts**

Key

- | | | | |
|---|---|----|---|
| 1 | pitch diameter | 6 | form of relief optional — width approximately central when undercut |
| 2 | minimum major diameter of product internal thread | 7 | pitch cylinder |
| 3 | minimum product internal thread | 8 | minimum minor diameter of product internal thread |
| 4 | gauge thread form | 9 | minimum pitch diameter of product internal thread |
| 5 | clear $0,125P$ when undercut | 10 | fingers |

^a The total segment contact to be a minimum of 25 % of circumference.

Figure 7 — Virtual pitch diameter indicating thread gauges for internal threads

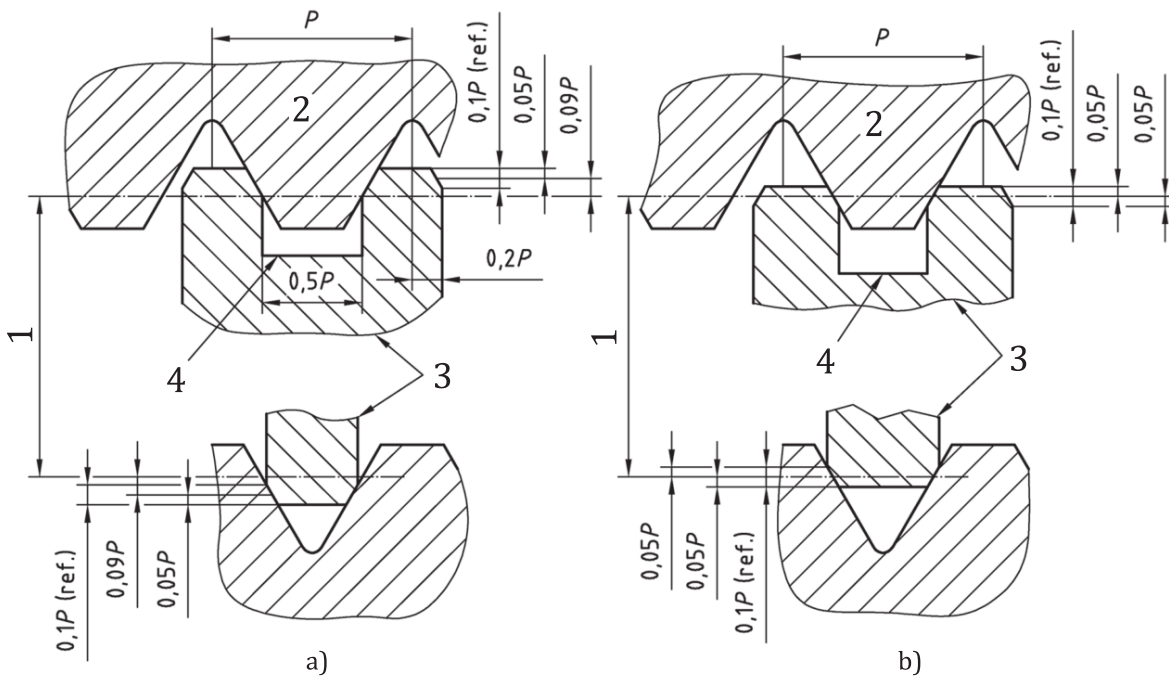

Contacts above pitch line^a

Contacts central on pitch line^a

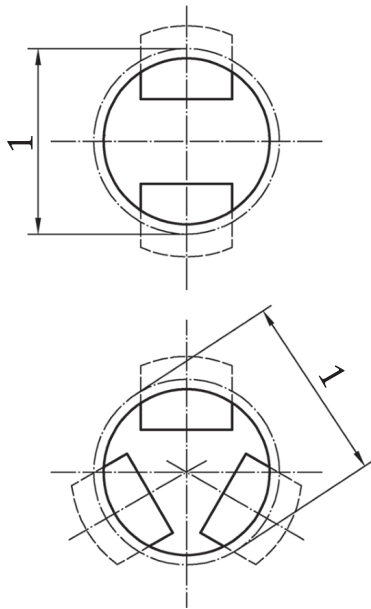

**Segments
two or three contacts^b**

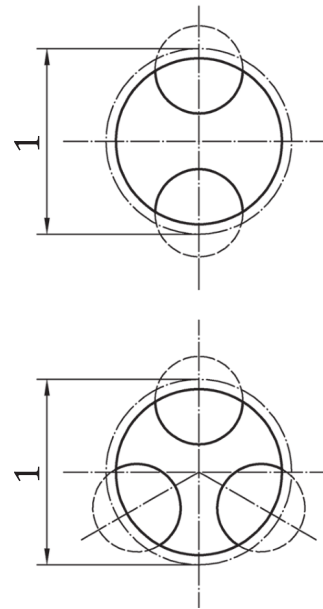

**Rolls
two or three contacts**

Key

1 pitch diameter 2 internal thread 3 gauging elements 4 form of relief optional

^a Alternate designs: Contacts in other positions near the pitch cylinder may also be applied.

^b The total segment contact to be 25 % or more of circumference.

Figure 8 — Simple pitch diameter indicating thread gauges with cone and vee for internal threads

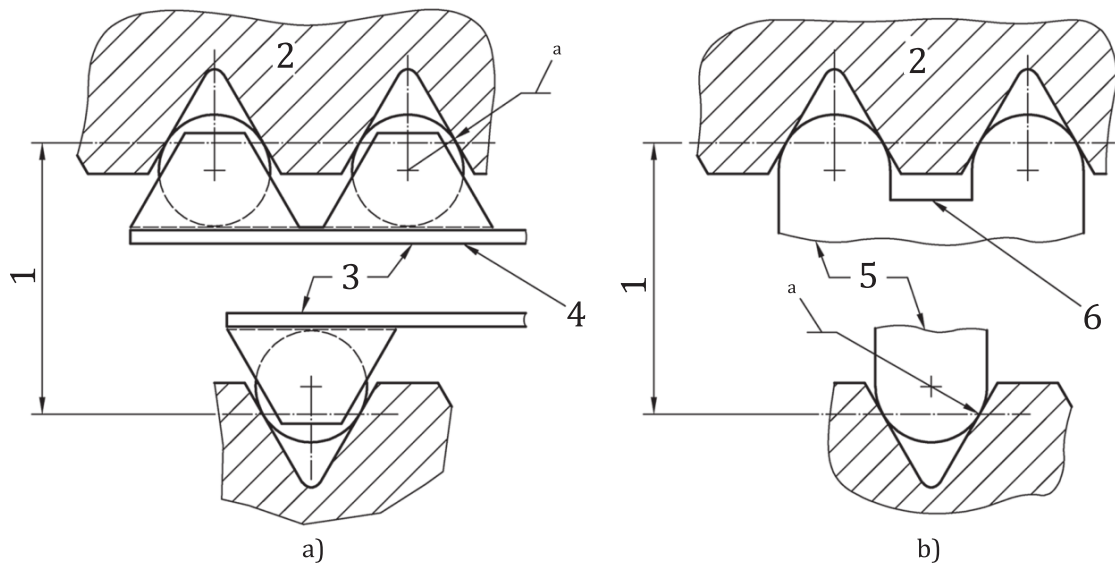

Three roll type: one rib on each roll, one third pitch apart

Two roll type: two ribs on one roll, one rib on other roll, one-half pitch apart

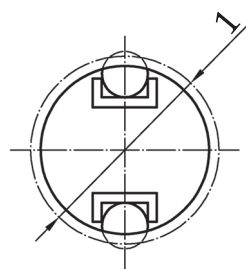

Ball design

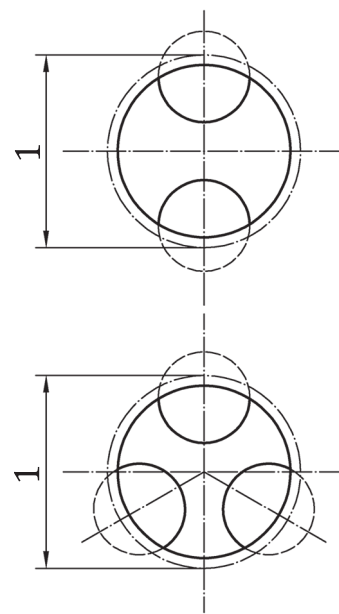

**Rolls
two or three contacts**

Key

- | | | | |
|---|--|---|---|
| 1 | pitch diameter | 5 | gauging contacts with one-half best size thread wire diameter |
| 2 | internal thread | 6 | form of relief optional |
| 3 | gauging contacts with best size thread balls | | |
| 4 | floating — spaced three pitches apart | | |
| a | Best wire size radius = $0,288\ 68P$. | | |

Figure 9 — Simple pitch diameter indicating thread gauges with radius roll for internal threads

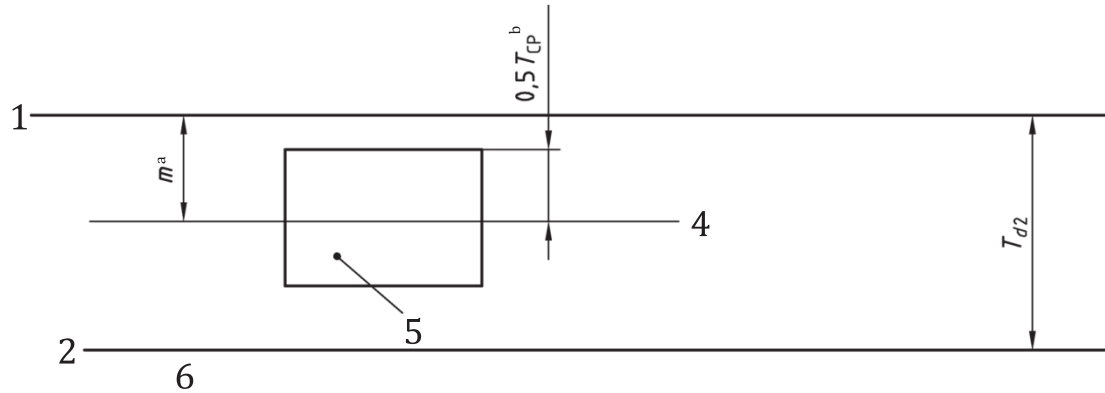

Key

- | | | | |
|---|---------------------------|---|-------------------------------|
| 1 | GO | 4 | average simple pitch diameter |
| 2 | NOT GO | 5 | gauge pitch diameter |
| 3 | maximum limit, max. d_2 | 6 | lower limit, min. d_2 |

a See 7.1.1

b See Table 2.

Figure 10 — Tolerance zone for the pitch diameter of GO thread setting plug gauges for external threads and gauge setting

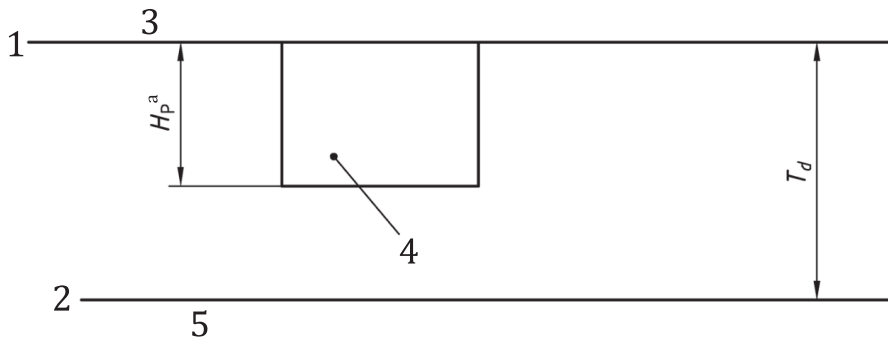

Key

- | | | | |
|---|---------------------------|---|-------------------------|
| 1 | GO | 4 | setting plug gauge |
| 2 | NOT GO | 5 | lower limit, min. d_2 |
| 3 | maximum limit, max. d_2 | | |

a See 6.1.4.

Figure 11 — Tolerance zone for setting plain plug gauges for major diameter of external threads

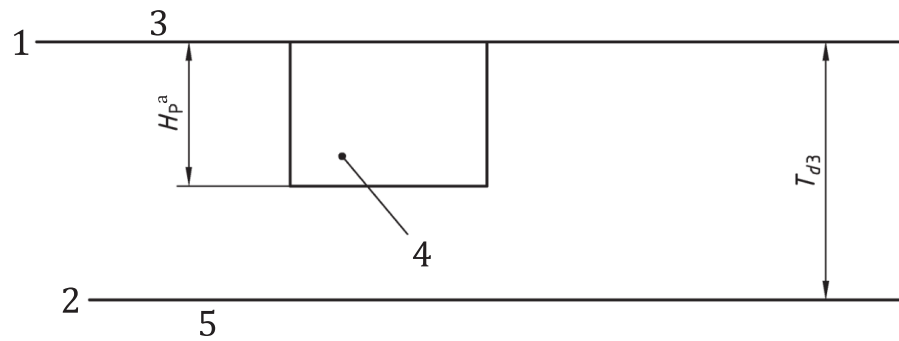

Key

- 1 GO
- 2 NOT GO
- 3 maximum limit, max. d_3 ^a
- 4 setting plug gauge
- 5 lower limit, min. d_3

^a See 6.1.5.

Figure 12 — Tolerance zone for setting plain plug gauges for minor diameter of external threads

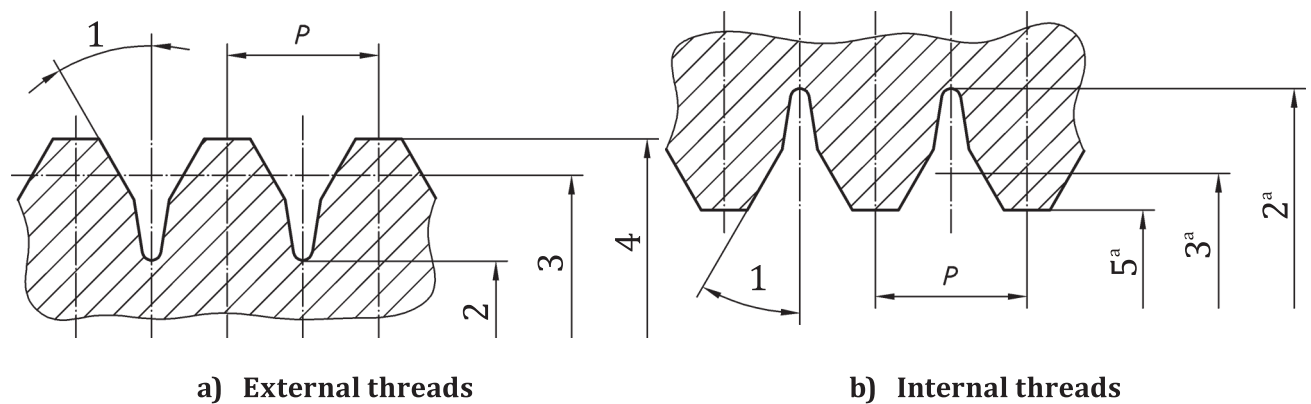

Key

- 1 $30^\circ \pm T_{\alpha 1}/2$ for profile with complete flanks
 $30^\circ \pm T_{\alpha 2}/2$ for profile with truncated flanks
- 2 clearing diameter
- 3 pitch diameter
- 4 major diameter
- 5 minor diameter
- ^a These diameters do not exist on anvils for GO (complete flanks) NOT GO (truncated flanks) screw calliper gauges.

Figure 13 — Half-angle profile

Bibliography

- [1] ISO 5408, *Screw threads — Vocabulary*
- [2] ISO 8015, *Geometrical product specifications (GPS) — Fundamentals — Concepts, principles and rules*
- [3] ISO 14253-1, *Geometrical product specifications (GPS) — Inspection by measurement of workpieces and measuring equipment — Part 1: Decision rules for proving conformity or nonconformity with specifications*
- [4] ISO 14638, *Geometrical product specifications (GPS) — Matrix model*
- [5] ASME B1.2, *Gages and Gaging for Unified Screw Threads*¹⁾

1) ASME International, 345 East 47th Street, New York, NY 10017-2392, USA.

