

First edition
2014-12-15

**Aircraft ground equipment -
Boarding vehicle for persons with
reduced mobility - Functional and
safety requirements**

*Matériel au sol pour aéronefs - Véhicule d'embarquement de
personnes à mobilité réduite - Exigences fonctionnelles et de sécurité*



Reference number
ISO 15845:2014(E)

© ISO 2014



COPYRIGHT PROTECTED DOCUMENT

© ISO 2014

All rights reserved. Unless otherwise specified, no part of this publication may be reproduced or utilized otherwise in any form or by any means, electronic or mechanical, including photocopying, or posting on the internet or an intranet, without prior written permission. Permission can be requested from either ISO at the address below or ISO's member body in the country of the requester.

ISO copyright office
Case postale 56 • CH-1211 Geneva 20
Tel. + 41 22 749 01 11
Fax + 41 22 749 09 47
E-mail copyright@iso.org
Web www.iso.org

Published in Switzerland

Contents

	Page
Foreword	iv
Introduction	v
1 Scope	1
2 Normative references	2
3 Terms and definitions	2
4 General requirements	4
4.1 Vehicle.....	4
4.2 Van body.....	6
4.3 Boarding platform.....	7
5 Controls	9
5.1 General.....	9
5.2 Upper operator's position.....	10
5.3 Driver's position.....	10
6 Stability and mobility	10
6.1 Stability requirements.....	10
6.2 Stabilizers.....	11
6.3 Mobility.....	11
7 Protection of persons	12
7.1 Safeguards against falling.....	12
7.2 Access.....	13
7.3 Malfunctions.....	13
8 Tail lift	14
9 Transfer plate	14
10 Back-up systems	15
11 Emergency evacuation	16
12 Optional features	16
13 Instructions and markings	16
13.1 Manufacturer's instructions.....	16
13.2 Markings.....	17
Annex A (normative) Minimum space requirements for a wheelchair or stretcher	18
Bibliography	20

Foreword

ISO (the International Organization for Standardization) is a worldwide federation of national standards bodies (ISO member bodies). The work of preparing International Standards is normally carried out through ISO technical committees. Each member body interested in a subject for which a technical committee has been established has the right to be represented on that committee. International organizations, governmental and non-governmental, in liaison with ISO, also take part in the work. ISO collaborates closely with the International Electrotechnical Commission (IEC) on all matters of electrotechnical standardization.

The procedures used to develop this document and those intended for its further maintenance are described in the ISO/IEC Directives, Part 1. In particular the different approval criteria needed for the different types of ISO documents should be noted. This document was drafted in accordance with the editorial rules of the ISO/IEC Directives, Part 2 (see www.iso.org/directives).

Attention is drawn to the possibility that some of the elements of this document may be the subject of patent rights. ISO shall not be held responsible for identifying any or all such patent rights. Details of any patent rights identified during the development of the document will be in the Introduction and/or on the ISO list of patent declarations received (see www.iso.org/patents).

Any trade name used in this document is information given for the convenience of users and does not constitute an endorsement.

For an explanation on the meaning of ISO specific terms and expressions related to conformity assessment, as well as information about ISO's adherence to the WTO principles in the Technical Barriers to Trade (TBT), see the following URL: [Foreword — Supplementary information](#).

The committee responsible for this document is ISO/TC 20, *Aircraft ground equipment*, Subcommittee SC 9, *Air cargo and ground equipment*.

Introduction

This International Standard specifies the functional and safety requirements for boarding vehicles used at airports for elevation, boarding and disembarkation of reduced mobility passengers to/from civil transport aircraft.

Throughout this International Standard, the minimum essential criteria are identified by use of the key word “shall”. Recommended criteria are identified by use of the key word “should” and, while not mandatory, are considered to be of primary importance in providing effective and intrinsically safe boarding vehicles. Deviation from recommended criteria should only occur after careful consideration, extensive testing, and thorough service evaluation have shown alternate methods to be satisfactory.

The requirements of this International Standard are expressed in the applicable SI units, with approximate inch-pound units conversion between brackets for convenience in those countries using that system. Where it is deemed necessary to use exact values, the SI unit ones are to be used.

1
2
3
4
5
6
7
8
9
10
11
12
13
14
15
16
17
18
19
20
21
22
23
24
25
26
27
28
29
30
31
32
33
34
35
36
37
38
39
40
41
42
43
44
45
46
47
48
49
50
51
52
53
54
55
56
57
58
59
60
61
62
63
64
65
66
67
68
69
70
71
72
73
74
75
76
77
78
79
80
81
82
83
84
85
86
87
88
89
90
91
92
93
94
95
96
97
98
99
100

Aircraft ground equipment - Boarding vehicle for persons with reduced mobility - Functional and safety requirements

1 Scope

1.1 This International Standard specifies the minimum functional and safety requirements for enclosed self-propelled boarding vehicles designed for transporting and boarding/de-boarding persons with reduced mobility onto/from the main deck or upper deck of main line civil transport aircraft on which they are travelling as a passenger.

1.2 The intent of this International Standard is not to specify equipment design, but rather to define minimum functional and safety requirements and highlight those criteria which are known to be essential to an efficient and safe operation on civil transport aircraft in the environment of international airports.

1.3 This International Standard specifies the worldwide requirements recognized by aircraft and vehicle manufacturers as well as airlines and airport authorities. In addition, it shall be applied with due reference to the national governmental regulations of the country where the vehicle is to be operated. The main though not exclusive areas in which such national regulations can apply are:

- general requirements applicable to road vehicles, or similar local airport regulations;
- sanitary requirements regarding design, cleaning, disinfection and equipment of vehicles that can be used to carry diseased persons with or without medical attendance;
- safety requirements applicable to elevating equipment carrying persons in the elevated position.

Nothing in this International Standard, however, shall be deemed to supersede any locally applicable law or regulation, unless a specific exemption has been obtained for this purpose from the appropriate Authority. See NOTE of [4.1.1](#) hereafter as regards legal requirements applicable in the European Union and EFTA.

1.4 This International Standard assumes that a disabled or incapacitated passenger can be accompanied by at least one attendant, and can be seated in a wheelchair or reclining on a stretcher trolley. Major factors in the design of the vehicle, with relevance to safety, are the consideration of psychological aspects, i.e. feelings of well-being and security, and the physical comfort of the passenger and the avoidance of panic.

1.5 This International Standard also assumes that any type of wheelchair, e.g. standard type with or without occupant self-restraint system, aircraft aisle width wheelchairs without armrests, non-occupant propelled wheelchairs, battery powered wheelchairs, etc., or any type of stretcher transport trolley, can be employed.

NOTE It is assumed that battery powered wheelchairs will not be taken into the cabin of an aircraft.

1.6 This International Standard does not apply to other forms of aircraft loading equipment which can be used but is not specifically designed for boarding of incapacitated or disabled persons, e.g. mobile lounges, passenger boarding bridges, or externally mounted pods such as used on medical evacuation helicopters.

1.7 This International Standard does not apply to unmodified automotive parts approved for public vehicles, e.g. chassis, when used on a boarding vehicle for the purpose for which they were designed.

1.8 Certain requirements of this International Standard are specifically dictated by overwing access to doors of certain aircraft types, and might not apply to other aircraft types. However, the intent of this International Standard is that any vehicle capable of reaching the upper deck of very large capacity aircraft (VLCA) shall be able to safely handle this specific situation.

2 Normative references

The following documents, in whole or in part, are normatively referenced in this document and are indispensable for its application. For dated references, only the edition cited applies. For undated references, the latest edition of the referenced document (including any amendments) applies.

ISO 6966-1, *Aircraft ground equipment — Basic requirements — Part 1: General design requirements*

ISO 6966-2, *Aircraft ground equipment Basic requirements Part 2: Safety requirements*

ISO 7000, *Graphical symbols for use on equipment — Registered symbols*

ISO 7010, *Graphical symbols — Safety colours and safety signs — Registered safety signs*

ISO 7718-1, *Aircraft — Passenger doors interface requirements for connection of passenger boarding bridge — Part 1: Main deck doors*

ISO 7718-2, *Aircraft — Passenger doors interface requirements for connection of passenger boarding bridge — Part 2: Upper deck doors*

ISO 10254, *Air cargo and ground equipment — Vocabulary*

ISO 10542-1, *Technical systems and aids for disabled or handicapped persons — Wheelchair tiedown and occupant-restraint systems — Part 1: Requirements and test methods for all systems*

ISO 10542-2, *Technical systems and aids for disabled or handicapped persons — Wheelchair tiedown and occupant-restraint systems — Part 2: Four-point strap-type tiedown systems*

ISO 10542-3, *Technical systems and aids for disabled or handicapped persons — Wheelchair tiedown and occupant-restraint systems — Part 3: Docking-type tiedown systems*

ISO 11228-1, *Ergonomics — Manual handling — Part 1: Lifting and carrying*

ISO 11532, *Aircraft ground equipment — Graphical symbols*

ISO 11995, *Aircraft — Stability requirements for loading and servicing equipment*

ISO 13849-1, *Safety of machinery — Safety-related parts of control systems — Part 1: General principles for design*

ISO 13857, *Safety of machinery — Safety distances to prevent hazard zones being reached by upper and lower limbs*

ISO 14122-2, *Safety of machinery — Permanent means of access to machinery — Part 2: Working platforms and walkways*

ISO 16004, *Aircraft ground equipment — Passenger boarding bridge or transfer vehicle — Requirements for interface with aircraft doors*

ISO 27470, *Aircraft ground equipment — Upper deck catering vehicle — Functional requirements*

DIN 51130, *Testing of floor coverings — Determination of the anti-slip property — Workrooms and fields of activities with slip danger, walking method — Ramp test*

3 Terms and definitions

For the purposes of this document, the terms and definitions given in ISO 10254 and the following apply.

3.1**attendant**

airline, airport or handling company person who can assist a disabled/incapacitated person

Note 1 to entry: Examples of the ways in which attendants can assist disabled persons are, e.g. pushing wheelchairs, operating hoists, assisting with entering and leaving seats, stretchers, and wheelchairs.

3.2**back-up**

separate means to ensure a function in the event of a primary power loss or system failure

3.3**boarding platform**

platform for transshipment between vehicle van body and aircraft

3.4**disabled person**

person with one or more impairments, one or more disabilities, one or more handicaps, or a combination of impairment, disability, and/or handicap, which restricts his/her mobility

3.5**emergency evacuation**

necessity to evacuate all persons on board of the vehicle to the ground in as short a time as possible, in order to escape an immediate major hazard, e.g. fire

Note 1 to entry: Since an emergency stop might have been actuated or the main vehicle systems damaged, the main power source can be unavailable.

3.6**incapacitated person**

person whose mobility is temporarily impaired

Note 1 to entry: Mobility impairments range from persons having difficulty walking due to use of a prosthetic to a quadriplegic.

3.7**person with reduced mobility**

PRM

person meeting definitions [3.4](#) or [3.6](#) above. He/She can move by oneself or on a wheelchair or a stretcher

3.8**rated load**

maximum mass (including persons) the vehicle is intended to carry. It is the lowest of applicable constraints, general structural strength (including lifting), capability of usable floor surfaces, vehicle's driving gross mass, maximum allowable occupancy (e.g. emergency exits), etc.

3.9**restraint device**

device for preventing movement of a person or a load

3.10**safety barrier**

movable element to prevent access into an area

3.11**safety shoe**

pressure-sensitive switch placed underneath the open door of an aircraft to detect excessive downward motion of the aircraft

3.12

side-guard

rigid device which is designed to prevent another vehicle from becoming entrapped underneath the side of a vehicle when the vehicle is struck from either side

3.13

stretcher trolley

wheeled trolley with integral or removable stretcher (which might be capable of being folded or dismantled), attendant operated, non-self-propelled

3.14

tail lift

tailgate

moveable platform at the rear of a vehicle used for assisting the entry or exit of passengers, with or without wheelchairs or stretcher trolleys, into and out of vehicles from the ground level

3.15

transfer plate

movable accessory used to bridge the aircraft door sill to smoothly roll in and out wheelchairs or trolleys

3.16

under-run guard

rigid or flexible bumper device which is designed to prevent another vehicle from becoming entrapped underneath the rear of a vehicle when the vehicle is struck from behind

3.17

van body

enclosed body for carrying loads, e.g. disabled/incapacitated persons, wheelchairs, stretcher trolleys

3.18

wheelchair

wheeled chair, either occupant-propelled, pushed or power operated, which might be capable of being folded or dismantled, fitted with or without an occupant restraint system

Note 1 to entry: Special, narrower, pushed wheelchairs limited to the airports and usually without armrests are used in order to move in aircraft cabins aisles.

4 General requirements

4.1 Vehicle

4.1.1 The vehicle's design, construction, equipment, and, where necessary, operating rules shall meet all the applicable requirements of ISO 6966-1 and ISO 6966-2.

NOTE For operation in Europe (EU and EFTA), EU Machinery Directive's essential safety requirements legally apply. They can be met by complying with the requirements of the following European Standards (see Bibliography):

- EN 1915-1, *Aircraft ground support equipment — General requirements — Part 1: Basic safety requirements*;
- EN 1915-2, *Aircraft ground support equipment — General requirements — Part 2: Stability and strength requirements, calculations and test methods*;
- EN 1915-3, *Aircraft ground support equipment — General requirements — Part 3: Vibration measurement methods and reduction*;
- EN 1915-4, *Aircraft ground support equipment — General requirements — Part 4: Noise measurement methods and reduction*;

— EN 12312-14, *Aircraft ground support equipment — Specific requirements — Part 14: Disabled/incapacitated passenger boarding equipment.*

In addition, the pertinent requirements of applicable governmental regulations such as EC Regulation N° 1107-2006 and FAA Advisory Circular N° 150/5220-21C shall be taken into account.

4.1.2 The vehicle shall be equipped with a fully enclosed elevating van body capable of safely lifting the maximum allowable rated load defined in [4.2.3](#), and a boarding platform capable of reaching the passenger door sill heights of the aircraft types it is intended to serve.

NOTE Door sill heights of current main line transport airplanes are usually over 2,50 m (100 in) and can be up to a maximum of 8,40 m (330 in) above the ground.

4.1.3 Where intended to use public roads, the vehicle's dimensions, laden weight, and other characteristics shall satisfy the applicable government regulations for vehicles.

4.1.4 The overall plan-view dimensions of the boarding vehicle shall be kept to a minimum, consistent with its functions. The overall width of the vehicle in the driving condition (with stabilizers retracted) should not exceed 2,60 m (102 in). The overall height of the vehicle in the fully lowered position shall not exceed 4,00 m (157 in), in order to be compatible with the airport infrastructures. In order to facilitate use on aircraft, the vehicle's overall length should preferably not exceed 12,20 m (40 ft). See [Annex A](#) for the dimensioning space requirements of wheelchairs and stretchers.

NOTE Local road traffic regulations can require narrower vehicle widths.

4.1.5 The vehicle's swept turning radius shall be kept to a minimum, and should not exceed 12,20 m (40 ft). The vehicle chassis shall be protected against adjacent vehicles by continuous aft under-run guard and side guards. The ground clearance of the boarding vehicle shall allow without interference the traversing of two surfaces intersecting at an angle of 3° (5 %) either in bridging or in cresting.

4.1.6 The width of any gaps between the different floors of van body, boarding platform and tail lift or parts thereof in the load transfer position shall be less than 10 mm (3/8 in). Height variation between the van body floor, boarding platform, and tail lift or parts thereof shall not exceed 6 mm (1/4 in). Where the difference in height is more than 6 mm in the load transfer position a ramp inclined at a maximum angle of 15° shall be provided.

4.1.7 The boarding vehicle's driver shall have maximum unobstructed view of the platform and aircraft interface and any potential interference areas (e.g. engines, wing) under all operating conditions. Particularly, for final positioning to the aircraft at walking speed, the driver's position while at the steering wheel shall provide a free line of sight towards these critical areas. Where the driver's position (see [5.3](#)) is not elevating with the van body, this visibility field can be achieved through appropriate window section(s), equipped with wiper and defrosting, in the cabin's roof, and either:

- a) on the boarding platform in its fully retracted position leaving the minimum visibility field unobstructed, or
- b) allowing it to be raised enough during final positioning to leave the visibility field unobstructed.

4.1.8 The boarding vehicle's rated load capacity shall be defined by the manufacturer, and consistent with maximum allowed occupancy as defined in [4.2.3](#). See [13.2](#) for rated load marking requirements.

4.1.9 The boarding vehicle's structural strength, and stability shall meet the applicable requirements and be accordingly demonstrated by testing, or numeric simulation substantiated as equivalent.

Calculations, testing and simulations shall be performed using recognised structural engineering codes.

The stability and strength requirements to be met are those resulting from the present international Standard (see [Clause 6](#) for stability requirements), as well as governmental regulations (e.g. EN 1915-2 for vehicles to be operated in Europe) or the codes derived from them.

4.1.10 The design of electrical equipment shall take into account any potential interference with passengers fitted with pacemakers, or electrical medical equipment. Consideration should be given to the requirements of IEC 60601-1 in relation with any medical equipment that can be used on the boarding vehicle.

4.2 Van body

4.2.1 The van body shall be sufficient to carry the passengers on wheelchairs or stretchers plus attendants and any ancillary equipment as intended. See [Annex A](#) hereafter for the minimum space requirements for a wheelchair. Minimum space requirements shall be 0,75 m × 1,20 m (30 in × 48 in) floor space for a wheelchair and 0,75 m × 2,10 m (30 in × 83 in) for a stretcher trolley, and in accordance with [Figure A.2](#) of [Annex A](#) for required clear pathway.

4.2.2 The van body floor structure shall be designed for a load of 2 000 N·m⁻² (42 lb/sq ft), equally distributed over its whole surface, but withstand without permanent deformation a local load of 3 600 N·m⁻² (75 lb/sq ft) on any single area of 0,9 m² (10 sq ft) or less. The maximum mass of a single wheelchair within the floor space defined in [Figure A.1](#) of [Annex A](#) shall be taken for calculation as 320 kg (700 lb).

NOTE This is composed of a mobility device maximum weight of 160 kg (350 lb) and a reduced mobility person's maximum weight of 160 kg (350 lb), in accordance with FAA AC N° 150/5220-21C (see [Clause 2](#)). The weight footprint of a stretcher trolley is considered to be always less.

4.2.3 Maximum occupancy of the van body (wheelchairs, stretchers, other persons) shall be defined by the manufacturer (see [13.1](#)). The van body's total rated load shall be a minimum of 400 kg (880 lb) where intended for a single wheelchair, adding 160 kg (350 lb) per other wheelchair or stretcher and 80 kg (175 lb) per attendant or other person. See [13.2](#) for rated load and maximum occupancy marking requirements.

4.2.4 The van body floor surface material shall be smooth and free from any joint or recess allowing accumulation of dirt or rubbish, provide the possibility of easy elimination of water and snow, and be selected to minimize wear and comply with cleaning and sanitary requirements. This material, even in a wetted condition, shall provide a durable slip-resistant surface, with a minimum R11 slip-resistance classification in accordance with Table 3 of DIN 51130. Drainage shall be provided for elimination of any spilled fluids. Any gaps or height variations in the floor material shall meet the requirements of [4.1.6](#).

Where the floor surface is carpeted, the carpet shall be low pile, hard friction, with a thickness not exceeding 13 mm (0,5 in). The above slip-resistance and fluids elimination requirements are entirely applicable.

4.2.5 The van body's internal clear height, with doors open or closed, shall be no less than 2,00 m (79 in), and should preferably be at least 2,10 m (83 in). The usable internal width should be no less than 2,30 m (91 in), if permitted by vehicle size and design within locally applicable vehicles outer width limitations.

4.2.6 The van body shall be equipped with at least two doors at the forward (boarding platform) and rear (ground access) ends, with a minimum usable width of 0,90 m (36 in) and a minimum clear height of 2,00 m (79 in) when open. If another door is provided for staff or attendants access, it shall have a minimum usable width of 0,75 m (30 in) and a minimum clear height of 2,00 m (79 in) when open.

4.2.7 Means shall be provided for access of persons with reduced mobility from the ground to the van body in the lowered position, e.g. lowering capability of the lifting system to ground level or installation of a tail lift (see [Clause 8](#)). Steps are not permitted for wheelchair or stretcher access. Where a ramp is used for wheelchair/stretcher access, it shall not exceed a slope of 5° (1/12 ratio), or 7° (1/8 ratio) if the length of the ramp does not exceed 1,5 m (5 ft).

4.2.8 The interior of the van body shall be fully lined with a smooth, non-moisture absorbent, non-toxic material, approved for utilization in sanitary facilities. In addition

- a) the lining material shall be compatible with repeated cleaning using strong detergents and disinfecting agents, as well as suitable for repeated water pressure and steam cleaning,
- b) any joints or appurtenances inside the van body shall be flush, rounded, sloped or otherwise protected to prevent any accumulation of dirt or rubbish and facilitate comprehensive cleaning, and
- c) the inner surfaces of the van body shall include no projections or corners that could cause injuries, e.g. corners shall be chamfered or rounded to a minimum radius of 6 mm (1/4 in), unless smooth corners are provided by the intrinsic design of the standard material profiles used in the construction.

4.2.9 The van body shall have windows along each longitudinal side. The windows should be located so that passengers on seats, wheelchairs and stretchers are able to look through.

4.2.10 Seats with a lap belt, that may be folding, or as a minimum standing stations with hand holds, shall be provided in the van body for as many attendants or other persons as the vehicle is intended to carry.

4.2.11 Restraint devices anchorage points shall be provided to restrain as many wheelchairs and/or stretcher trolleys as the vehicle is intended to carry. The design of restraint devices and anchorage points shall be capable of withstanding the imposed loads (see [4.2.2](#) for maximum wheelchair mass to be taken into account) under driving conditions up to the maximum driving speed of the boarding vehicle. Restraint systems where provided shall be designed according to ISO 10542-1, ISO 10542-2, or ISO 10542-3.

4.2.12 The van body shall be ventilated with a minimum fresh air rate of 50 m³·h⁻¹ (30 cu ft/min). Heating and/or air conditioning shall be considered in accordance with the weather conditions at the airport of operation. Combustion heating open flame heaters are not permissible.

4.2.13 Ambient lighting shall be fitted within the van body to provide a minimum illumination of 150 lx (15 ft-candle) at any point of the floor including access areas and 200 lx (20 ft-candle) in a horizontal plane located 0,8 m (30 in) over the floor. Emergency lighting shall be provided and ensure a minimum of 10 lx (1 ft-candle) at the floor in the event of main lighting system failure.

4.3 Boarding platform

4.3.1 The vehicle shall be equipped with a boarding platform enabling safe transshipment of reduced mobility persons between the van body and the aircraft. The boarding platform may consist of a fixed part and (a) movable part(s), which can be telescoping, sliding, turning, folding or otherwise adapting, and shall be level with the van body floor within the required working height range according to the aircraft types intended to be served (see [4.1.2](#)).

NOTE 1 Boarding platforms can be an integrated extending part of the van body. As an option, they can be fully enclosed or covered with a fixed or retractable canopy (see [4.3.10](#) for aircraft interface).

NOTE 2 Where the vehicle is intended to serve the upper deck of very large capacity aircraft (VLCA), an additional requirement applies to provide an aircraft wing overhanging capability. See ISO 27470, 3.4.9, Upper deck catering vehicle, for resulting specific requirements which are also applicable to PRM boarding vehicles.

4.3.2 The boarding platform shall have a minimum usable length of 1,20 m (48 in) where only wheelchairs are considered, or 2,10 m (83 in) where stretchers can be carried. Its minimum clear width between side panels shall be 0,90 m (36 in) as per [Figure A.2](#) of [Annex A](#).

4.3.3 The boarding platform shall be fitted on both sides with continuous side panels with a minimum height of 1,10 m (43 in) to continuously close the gap between the van body and the aircraft during operation. The side panels shall include a fixed part and a forward part adjustable to the aircraft. They

shall be entirely filled, support continuous handrails (see [7.1.2](#)), and comply with ISO 14122-2 geometry and strength requirements for guard-rails.

4.3.4 The adjustable part of the side panels shall be fitted with a positive locking device fitted with a handle release, in either deployed or stored position, with as many intermediate positions as may be necessary. It shall be possible to deploy and retract the adjustable part of side panels without putting the operator into an unsafe position.

4.3.5 For this purpose, it is recommended adjustment movements be powered and controlled from the upper control panel (see [5.2](#)). The adjustable sections to close the gap with the aircraft fuselage may remain manual, but with an operating force not exceeding 60 N (15 lbf).

NOTE Alternately, the side panels can be replaced by an enclosed boarding platform with overhead canopy. The same requirements apply for adjustment and aircraft door opening (see [12.1](#)).

The maximum force exerted onto the aircraft by telescopic parts of the boarding platform and guard-rails/side panels shall not exceed 400 N (90 lbf). When the maximum force caused by movement of the aircraft exceeds 400 N (90 lbf), these telescopic parts shall give way.

4.3.6 An aircraft docking configuration shall provide a safe position for opening and closing the aircraft door: in the docking configuration, the minimum clear width between the inner faces of side panels shall be equal to the added widths of the aircraft door in the open and closed positions, plus a positioning clearance commensurate with the nature and accuracy of the docking systems/width adjustment devices. Where this requirement cannot be met, e.g. for certain half-cabin vehicles, the boarding platform's design shall provide equivalent protection against the risk of the operator falling while opening and closing the aircraft door.

4.3.7 The fixed section of the boarding platform shall be designed to support a minimum total distributed load of 5 900 N (1 320 lb), or 3 600 N·m⁻² (75 lb/sq ft), whichever is highest, or a minimum 3 140 N (700 lb) concentrated load on either forward quarter area of the fixed part, without deflecting by more than 6 mm (1/4 in). No permanent deformation is allowable.

4.3.8 The movable section(s) of the platform shall be designed to support a minimum total distributed load of 3 450 N (770 lb), or 3 600 N·m⁻² (75 lb/sq ft) of maximum deployed area, whichever is highest, or a minimum local single load of 980 N (220 lb) at its (their) leading edge when fully extended. The maximum deflection of the leading edge shall not exceed 20 mm (0,8 in) under the maximum allowed loads of the platform. No permanent deformation is allowable.

4.3.9 Continuous flooring shall be provided between the side panels, including in temporary docking or operating positions where different from the travelling one. The floor material, even in a wetted condition, shall provide a durable slip-resistant surface, with a minimum R11 slip-resistance classification in accordance with Table 3 of DIN 51130. Drainage shall be provided for elimination of water and snow. Any gaps or height variations in the floor material shall meet the requirements of [4.1.6](#).

4.3.10 The boarding platform and the side panels adjacent to the aircraft shall provide an adaptation to its contours. They shall conform to the interface requirements given in ISO 7718-1, if applicable ISO 7718-2, and ISO 16004. Side panels adjustment shall leave a maximum gap of 120 mm (5 in) from protective padding to the aircraft fuselage.

4.3.11 The forward edge of the boarding platform and side panels shall be designed so that damage to the aircraft is avoided, as a minimum by a full width aircraft interface device (padding) designed to protect the aircraft, that

- is of a non-marking semi-soft material with a Shore surface hardness not exceeding A50,
- ensures a minimum 60 mm crushing capability, and

— is designed to minimize any force locally exerted onto the aircraft (see [4.3.5](#)).

Padding can be complemented by proximity detection devices or flexible aircraft contact detection devices. In this case, the device shall provide an electrical signal when or before contact with the aircraft is achieved at any point, that can be used to stop vehicle movement. The related interlocking systems shall ensure a Performance Level “b” according to ISO 13849-1.

4.3.12 The boarding platform shall be designed so that damage to the aircraft door, open during boarding/de-boarding, as a result of aircraft movement is avoided. This can be achieved by either

- leaving the space underneath the aircraft door in the open position unconfined. All safety requirements in [4.3.3](#) and [4.3.6](#) shall be complied with, or
- a mechanism, e.g. sensor or safety “shoe” which prevents the aircraft door from setting upon the boarding platform during dispatch of the aircraft. The related systems shall ensure a Performance Level “b” according to ISO 13849-1.

4.3.13 In order to prevent the hazards resulting from handling persons and heavy items high above the ground without a complete safeguard, all movements of movable platform parts should be powered and controlled from the upper control panel (see [5.2](#)).

4.3.14 A safe operator position shall be provided either on the fixed part of the boarding platform or the forward part of the van body to allow direct visibility of the aircraft interface area during vehicle positioning. It shall be within reach of the upper control panel (see [5.2](#)) and protect the operator against the risk of falling while the platform’s movable part(s) and corresponding side panels are not yet extended and locked.

4.3.15 In order to facilitate positioning at aircraft doors interface at night and under poor visibility conditions, a working light shall be provided on the platform or forward exterior face of the van body, to provide the platform and aircraft interface area with a non-glare minimum illumination of 200 lx (20 ft-candle).

5 Controls

5.1 General

5.1.1 Controls for raising and lowering the van body as well as the boarding platform shall be provided at the driver’s position and at an upper operator’s position. These controls shall be interlocked so that only one position is enabled at a given time. Selection of raising and lowering priority between both controls shall be located only at the upper operator’s position. The related interlock system shall ensure a Performance Level “c” according to ISO 13849-1

5.1.2 It shall be possible to start and stop the engine from both the driver’s position and the upper control panel.

5.1.3 Emergency stop (engine kill) buttons in accordance with ISO 6966-2, 4.9.1 shall be provided at both control panels. Where an additional emergency stop is provided, it shall be accessible from ground level, on the vehicle side opposite the driver’s position. Activation of an emergency stop shall not activate the travelling brakes.

5.1.4 Non-lockable hold-to-run control actuators shall be used for all functions except vehicle travelling. All controls shall be identified by the appropriate ISO 11532 graphic symbol for their function.

5.1.5 The layouts of control panels should, insofar as practical, meet the requirements of IATA AHM 915 (see Reference [\[5\]](#)).

5.2 Upper operator's position

5.2.1 The upper control panel shall be located at the forward end of the van body, or on the fixed section of the boarding platform under the requirement that the corresponding operator's position be fully protected by the platform's side panels and the safety barrier (see [7.1.3](#)). Its location shall ensure an unobstructed view over the platform, side panels, and aircraft interface area.

5.2.2 All functions for positioning and adjusting the vehicle at the aircraft, except vehicle travelling, shall be controllable from the upper control panel (see [4.3.14](#)). Controls for any powered movable parts of the boarding platform, side panels sections and optional canopy shall be provided only at the upper control panel.

5.3 Driver's position

5.3.1 The driver's position shall be seated, and might be located either on the chassis at ground level, or on the elevating platform supporting the van body. In the first case, it shall be contained in an automotive vehicle cabin or equivalent enclosed location. In the second case, it shall be separated from the van body's interior by at least a half-height partition or gate, and shall not obstruct direct passage of wheelchairs or stretchers to and from the aircraft (see [Figure A.2](#) of [Annex A](#) for minimum required through way).

5.3.2 Travelling controls shall be provided only at the driver's position.

5.3.3 Controls for extending and retracting the stabilizers if provided (see [6.2](#)) shall be located only at the driver's position control panel, and shall be protected against inadvertent activation. Positive confirmation by warning lights or equivalent that the stabilizers are either fully retracted, or fully extended and supporting the vehicle's weight against a supporting surface, shall be provided at both the driver's position and the upper control panel.

5.3.4 An indication showing the van body is not fully lowered shall be provided at the driver's position.

5.3.5 Where a warning device is provided to indicate when a van body door is open, it shall be installed at the driver's position.

6 Stability and mobility

6.1 Stability requirements

6.1.1 The vehicle in both the maximum payload and empty conditions shall meet the static and wind stability requirements of ISO 11995 with both the van body and front platform in the maximum elevated positions and the most unfavourable distribution of loads.

6.1.2 The required stability can be achieved either intrinsically by design, or through the use of stabilizers. See [6.3](#) hereafter for associated mobility restrictions in either case.

6.1.3 In addition to actual calculated or tested stability, i.e. prevention of the risk of the vehicle tipping over, utmost design care should be brought to minimizing any feeling of instability for persons standing on the boarding platform in the elevating position, resulting from vehicle structure oscillations and perceived vibrations due to wind gusts or movement of persons and loads on board the vehicle. For instance

- stabilizers and their attachment structure should be designed to eliminate any flexibility,
- mechanical play between structural or lifting system parts should be minimized,
- structural parts found to contribute to flexibility and oscillations should be stiffened,

- damper devices should be provided where effective,
- wheelchair and trolley rolling surfaces should be as smooth as possible,
- side panels should be provided with a positive locking device ensuring they do not deflect, and
- etc., according to vehicle design.

6.1.4 Stability in the intended conditions of use shall be demonstrated by the manufacturer in accordance with [4.1.9](#).

6.2 Stabilizers

6.2.1 Unless stability is ensured by intrinsic means, a minimum of four retractable stabilizers shall be provided for van body elevation. If stabilizers are provided, their controls shall be located at the driver's position (see [5.3.3](#)).

6.2.2 Stabilizers shall be so designed that it is possible to compensate gradients up to 1,5° (2,5 %) and unevenness in the ground. Base plates shall be capable of being pivoted in all directions at least 5° from the horizontal plane when in the working position.

6.2.3 The stabilizers in the retracted position shall not protrude from the vehicle's overall width defined in 4.1.4.

6.2.4 The stabilizers in the extended position with the van body elevated at aircraft main deck height [up to 5,60 m (220 in) over the ground] should preferably not protrude from the vehicle's overall width, and in any event shall not protrude out of the vehicle width by more than 0,30 m (12 in) on each side.

6.2.5 The stabilizers in the extended position with the van body elevated at aircraft upper deck height [over 6,00 m (240 in) over the ground] may protrude from the vehicle width to the extent required to meet the stability objectives, but shall not protrude out of the vehicle width by more than 0,75 m (30 in) on each side.

6.2.6 Stabilizers collapse or uncontrolled lowering of van body and/or boarding platform in the event of any system failure or as a result of unintentional shift shall be prevented by fail-safe mechanical devices in both the working and retracted positions.

6.3 Mobility

6.3.1 It shall not be possible to drive the vehicle when the stabilizers were not retracted or the van body is not in the fully lowered position, unless the vehicle has been designed to meet the ISO 11995 stability objectives under this operational condition.

6.3.2 Retraction of stabilizers shall not be possible under normal or emergency conditions until the van body has been lowered to no more than 2,50 m (100 in) height, or within the ISO 11995 stability objectives.

6.3.3 It shall not be possible to raise the van body above 2,50 m (100 in) height unless the stabilizers are fully extended and supporting the vehicle's weight against a supporting surface.

6.3.4 It shall not be possible to raise the boarding platform when stabilizers are not extended, unless the ISO 11995 stability objectives are met.

6.3.5 The boarding vehicle should be capable of moving at a smooth, non-jerking speed not exceeding 0,7 m·s⁻¹ (2,5 km·h⁻¹, 1 ½ mph). In addition, where designed to travel with the van body or boarding platform raised, it shall be limited to a speed not exceeding 6 km·h⁻¹ (3 ¾ mph) in either forward or aft

directions when in this condition. For final positioning, it should be possible to move the vehicle at an inching speed not exceeding $0,2 \text{ m}\cdot\text{s}^{-1}$ ($0,8 \text{ km}\cdot\text{h}^{-1}$, $\frac{1}{2}$ mph). Alternately, final positioning can be ensured by a telescopic section of the boarding platform. In this case, the telescoping speed shall not exceed $0,1 \text{ m}\cdot\text{s}^{-1}$ ($0,4 \text{ km}\cdot\text{h}^{-1}$, $\frac{1}{4}$ mph).

6.3.6 In order to allow development by the manufacturing industry, the final positioning requirements in [6.3.5](#) are intended to become mandatory within this International Standard at its next revision (5 years from its publication date). See ISO 6966-2 for aircraft contact protection or detection systems to be considered.

6.3.7 The interlocking systems corresponding to the requirements in [6.3.1](#) to [6.3.5](#) shall ensure a Performance Level “c” according to ISO 13849-1. For the requirements of [6.3.1](#) and [6.3.2](#), a manual override of this interlock shall be possible for emergencies (see [10.5](#)).

7 Protection of persons

7.1 Safeguards against falling

7.1.1 Safeguards against falling shall be provided on all open sides of the boarding platform except for access to the van body, as follows.

7.1.2 The side panels on both sides shall be fitted with continuous handrails at 1,10 m (43 in) height, conforming with the geometry and strength requirements of ISO 14122-2.

- a) Full continuity shall be maintained at all points between handrail segments. For handrail segments placed side by side, the distance between overlapping segments shall be 6 mm ($\frac{1}{4}$ in) maximum in accordance with ISO 13857, 4.2.4.1.
- b) Handrails shall not include projections or corners that could cause injury. They shall be smooth including the underside. Open junctions are not allowed. Edges or corners shall be rounded with a minimum radius of 6 mm ($\frac{1}{4}$ in).

NOTE Where the side panels height exceeds 1,10 m, an inner handrail between 1,00 and 1,10 m height is intended to be provided.

7.1.3 A movable safety barrier shall be provided across the boarding platform for eliminating or reducing the risk of falling of persons from the platform when the vehicle is not completely connected to the aircraft. The safety barrier shall

- a) meet the requirements of ISO 14122-2 for guard-rails and be capable of being latched in position,
- b) be located so as to allow actuating the movable side panels to/from the docking configuration as well as the upper control panel from a position protected by the latched barrier (see [4.3.14](#)), providing continuous flooring and complete enclosure by guard-rails,
- c) be clearly visible from either side, including at night and in fog,
- d) be padded to avoid any damage where it may interfere with open aircraft doors or doors being opened, and
- e) be easy to unlatch and handle by one person with a force not exceeding 60 N (15 lbf), and able to be stowed safely, i.e. retained in the stowed position by a positive fit device requiring deliberate action for release.

7.1.4 Barrier opening should be prevented unless the boarding platform’s forward edge has achieved contact with the aircraft and both platform side panels have been fully extended. “Contact”, for this purpose, means the maximum distance between any point of the platform’s and side panels forward edge

and the aircraft fuselage does not exceed 120 mm (5 in). The related sensors and interlocking systems (see [4.3.11](#)) shall ensure a Performance Level “b” according to ISO 13849-1.

7.1.5 Lifting and lowering of the boarding platform shall be prohibited unless the safety barrier is deployed into position and latched. The related interlocking systems shall ensure a Performance Level “c” according to ISO 13849-1.

7.1.6 See [Clause 8](#) as regards safeguards against falling on a vehicle tail lift.

7.2 Access

7.2.1 The van body shall be equipped with a door accessible from the ground for staff or attendants access while in its lowered position. This door may be one of the van body doors specified in [4.2.6](#). If separate, it shall have a minimum usable width of 0,75 m (30 in) and a minimum clear height of 2,00 m (79 in), and be able to be opened from both sides. Doors and gates shall not open towards the outside of the vehicle.

7.2.2 This door shall be accessible from the ground in the absence of power (without operating the tail lift) through vertical or preferably stair steps. The steps shall be fitted with anti-slip treads and tread noses as well as handholds or a handrail.

7.2.3 Where direct access from the ground to the boarding platform while in its lowered position is also provided, it shall include steps as per [7.2.2](#) and a self-closing gate through the side panel, meeting the requirements of ISO 14122-2 and [7.1.2](#).

7.2.4 It shall not be possible to open a door or a gate in an elevated position higher than 0,30 m (12 in) over resting, except the door between the van body and the boarding platform. This also applies to the outer door of a cabin elevated with the van body and to self-closing gate used for direct access to the boarding platform.

7.2.5 It shall not be possible to raise the van body higher than 0,30 m (12 in) over the lowered (resting) position with a door open, except the door between the van body and the boarding platform. In both instances outlined in [7.2.4](#) and [7.2.5](#), the related interlocking systems shall ensure a Performance Level “b” according to ISO 13849-1

7.3 Malfunctions

7.3.1 Hydraulic van body and boarding platform lifting system(s) shall be equipped with an automatic fail-safe device to limit unintentional lowering to a maximum of 100 mm and to stop the platform at any height, in the event of hydraulic supply line rupture. This device shall be designed to carry 150 % of the rated load.

7.3.2 Devices shall be fitted to stop the descent of the van body and boarding platform if the descent speed exceeds the maximum design speed. The platform shall be stopped before the descent speed exceeds $0,25 \text{ m}\cdot\text{s}^{-1}$. This does not apply to structural failure. If line rupture valves are used to stop the platform on (a) multi-cylinder lifting system(s), it shall be impossible for any hydraulic cylinder to be overloaded by more than 100 %.

7.3.3 A risk assessment conducted by the manufacturer shall identify the other potential vehicle malfunctions capable of resulting in a hazard for persons, and safety devices or functions shall be implemented in order to prevent them.

8 Tail lift

8.1 The tail lift if provided shall be designed according to EN 1756-2 [ISO equivalent TBD]. It shall accommodate at least one wheelchair and attendant, or one stretcher trolley and attendant if intended. Its surface material shall meet the slip-resistance requirements of [4.2.4](#).

8.2 It shall only be possible to drive the boarding vehicle or to lift or lower the van body with the tail lift in a defined safe stowing position. The related interlocking systems shall ensure a Performance Level “b” according to ISO 13849-1.

8.3 Means shall be provided to prevent persons from falling off the tail lift during operation. They shall include at least one 1,10 m (43 in) high guard-rail on each side, meeting the requirements of ISO 14122-2.

If foldable to allow tail lift stowage, the guard-rails direction of swing or tilt shall not be outwards and, in the protective position, these guard-rails shall be secured against moving by an automatic positive fit.

8.4 Restraint means, automatic or usable by the attendants, shall be provided to prevent an un-braked wheelchair or stretcher trolley from inadvertently rolling off the tail lift in any position.

8.5 Tail lift controls shall be provided both on the ground level, adequately protected from interferences and weather, and inside the rear part of the van body, with full visibility over the lift’s surface.

9 Transfer plate

9.1 A transfer plate accessory shall be provided to enable bridging the door sill between the boarding platform and the aircraft to safely and smoothly roll in and out wheelchairs and stretcher trolleys.

NOTE A set of different transfer plates can be required for the variety of aircraft types to be serviced. See [13.1](#), Instructions, for listing by the manufacturer of the aircraft types and doors the vehicle is intended to serve.

9.2 The transfer plate while in use shall be held to the boarding platform so as to prevent any risk of relative slippage or the plate becoming otherwise dislodged. This can be achieved by either

- the transfer plate being permanently attached or hinged to the forward part of the boarding platform, or
- it being a removable item, with provisions in the forward part of the boarding platform to position it with positive mechanical restraint against slippage and disengagement.

Where a removable transfer plate is used, a safe stowage location once removed shall be provided, including securing devices to prevent the transfer plate from moving or falling during transport.

9.3 In either case, the attachment or interface provisions shall allow longitudinal and lateral adjustment of the transfer plate’s position in order to allow an accurate fit in relation to the aircraft door sill.

9.4 The transfer plate shall be profiled to rise in its centre area (of the long axis) to avoid hinging around the aircraft door sill. Its underside shall be designed or protected to avoid damage to the aircraft door sill or flooring.

9.5 The design of the transfer plate shall ensure smooth transition of the wheelchairs/stretcher trolleys from the boarding vehicle to the aircraft and back. The walking surface shall meet the requirements of [4.3.9](#). Any discontinuity shall meet the requirements of [4.1.7](#).

9.6 In order to minimize the ergonomic constraint for the operators, the design shall ensure that the horizontal force to be exerted to move a 120 kg (265 lb) wheelchair or stretcher trolley does not exceed

225 N (50 lbf) for handling by one person as per ISO 11228-1. This requires, within the foreseeable range of relative height variation between the aircraft and the boarding platform, a transfer plate long enough not to exceed an angle of 12 degrees from the horizontal.

9.7 The minimum width of the transfer plate shall be 0,60 m (24 in) in order to accept aisle-width wheelchairs designed for entry into aircraft. Wider transfer plates in excess of 0,75 m (30 in), where possible according to the aircraft type, facilitate operators work, and may accept a passenger's own folding wheelchair.

NOTE 1 It is assumed that stretcher trolleys do not enter aircraft, the stretcher being removed and carried by hand.

NOTE 2 In the case of a removable transfer plate, the requirements of 9.6 and 9.7 can be achieved by using different plates according to the aircraft type. See 13.1, Instructions, for listing by the manufacturer of the aircraft types and doors the vehicle is intended to serve.

9.8 The minimum height of the transfer plate's side/toe rails shall be 100 mm (4 in).

NOTE Since this constitutes a significant part of the plate's stiffness, it will often be advisable for the longer plates to use higher sides in order to minimize weight.

9.9 The transfer plate's strength shall be sufficient to withstand an operator and a 120 kg (265 lb) wheelchair or stretcher trolley without permanent deformation. The force to be manually applied for its positioning, removal or storage shall not exceed 225 N (50 lb), in accordance with ISO 11228-1 for handling by one person. Handholds capable of being used with a gloved hand shall be provided for positioning and handling.

10 Back-up systems

10.1 The vehicle shall be equipped with (a) back up system(s) to

- retract and lower the boarding platform,
- lower the van body,
- retract the stabilizers if provided, and
- tow the vehicle away

in the event of a primary power or system failure.

10.2 The tail lift if provided shall be equipped with a back-up system able to lower and lift it for as many cycles as necessary to evacuate in an emergency the maximum allowable number of wheelchairs, stretchers, and attendants.

10.3 The back-up systems shall operate from a power source independent from the vehicle's primary power. Their controls, except for the tail lift, shall be located at the driver's position, accessible only by positive action, and be protected by a cover or equivalent.

10.4 Back-up system lowering shall not compromise vehicle stability, i.e. it shall not be possible to retract the stabilizers using the back-up system while the van body is above 2,50 m (100 in) height, unless the vehicle has been designed to meet the ISO 11995 stability objectives under this operational condition.

10.5 Whenever chassis propulsion is still available while the van body cannot be completely lowered, it shall be possible to manually override the interlock preventing the vehicle being driven while the van body is not fully down. The override control shall be located together with the other back up controls and sealed or otherwise protected against inadvertent or unauthorized use.

11 Emergency evacuation

11.1 Systems and procedures shall be provided to perform if required an emergency descent then a complete evacuation of all wheelchair and stretcher passengers from the vehicle in the lowered position to the ground, in the event of an emergency.

11.2 It shall be possible to operate an emergency evacuation while the vehicle is subject to a primary power loss or system failure (see [Clause 10](#)).

12 Optional features

12.1 The following optional additional features can be considered:

- stowage for a drinking water supply;
- stowage for hand baggage and umbrellas;
- stowage for unoccupied wheelchairs;
- stowage for pillows, blankets and first-aid equipment;
- stowage for medical equipment and/or therapeutic oxygen supplies, crutches or walking aids;
- communication system between the van body and driver's position;
- interior heating and/or air conditioning;
- automatic levelling system for boarding platform adjustment during aircraft height changes;
- detection device on the boarding platform that initiates a flashing light or audible alarm, in the event of the vertical clearance between platform and aircraft door becoming too small;
- fixed, sliding or folding canopy over the boarding platform. The canopy shall not interfere with opening and closure of aircraft doors, and shall meet the requirements of [4.3.10](#);
- guidance system to assist the driver for accurate positioning at aircraft;
- CCTV system to improve aft visibility when backing the vehicle away from aircraft or terminal.

12.2 Where one or several of these or other optional items is (are) provided, it (they) shall not compromise either of the safety requirements in [Clauses 4](#) to [7](#). The manufacturer shall carry out a specific risk assessment taking into account potential overlapping influences.

13 Instructions and markings

13.1 Manufacturer's instructions

Operating and maintenance instructions shall be supplied by the manufacturer with each boarding vehicle. They shall contain, appropriate to the design of the boarding vehicle, information about the following:

- aircraft types and doors the vehicle is intended to serve;
- allowable wind limitations;
- maximum allowable occupancy, rated load, rationale and loading conditions;
- wheelchairs, stretcher trolleys and persons safety;
- boarding platform and tail-lift operation;

- positioning of the vehicle at the aircraft;
- safety procedures for opening and closing aircraft doors;
- measures to be taken in the event of emergency situations or vehicle breakdown;
- routine checks to be carried out by the operator;
- minimum training programme for the operators;
- safety requirements for maintenance resulting from the specific design of the vehicle;
- positioning and use of the transfer plate(s).

13.2 Markings

13.2.1 The vehicle shall bear the general markings, including maximum rated load, required by ISO 6966-1, 6.6 and ISO 6966-2, Clause 5.

13.2.2 The interior of the van body shall also bear in a prominent location a placard indicating the maximum allowable occupancy in wheelchairs, stretchers, and attendants.

13.2.3 The maximum allowable occupancy of the boarding platform shall be similarly indicated by a placard, preferably located on the forward face of the van body exterior, visible from the aircraft and any point on the platform.

13.2.4 Any necessary advice to passengers and attendants shall be posted inside the van body, preferably using the appropriate ISO 7000 (e.g. ISO 7000 symbol 0100) or ISO 7010 international graphic symbols due to variability of international passengers language abilities.

13.2.5 In large size vehicles, it is recommended that the locations, anchorage points and restraint positions for wheelchairs and stretcher trolleys be identified by painted lines on the floor or interior linings.

Annex A (normative)

Minimum space requirements for a wheelchair or stretcher

A.1 Clear floor space

The minimum dimensions of the clear floor needed to accommodate a single wheelchair or stretcher are 0,75 m (30 in) wide by respectively 1,20 m (48 in) or 2,10 m (82 in) long, as shown in [Figure A.1](#).

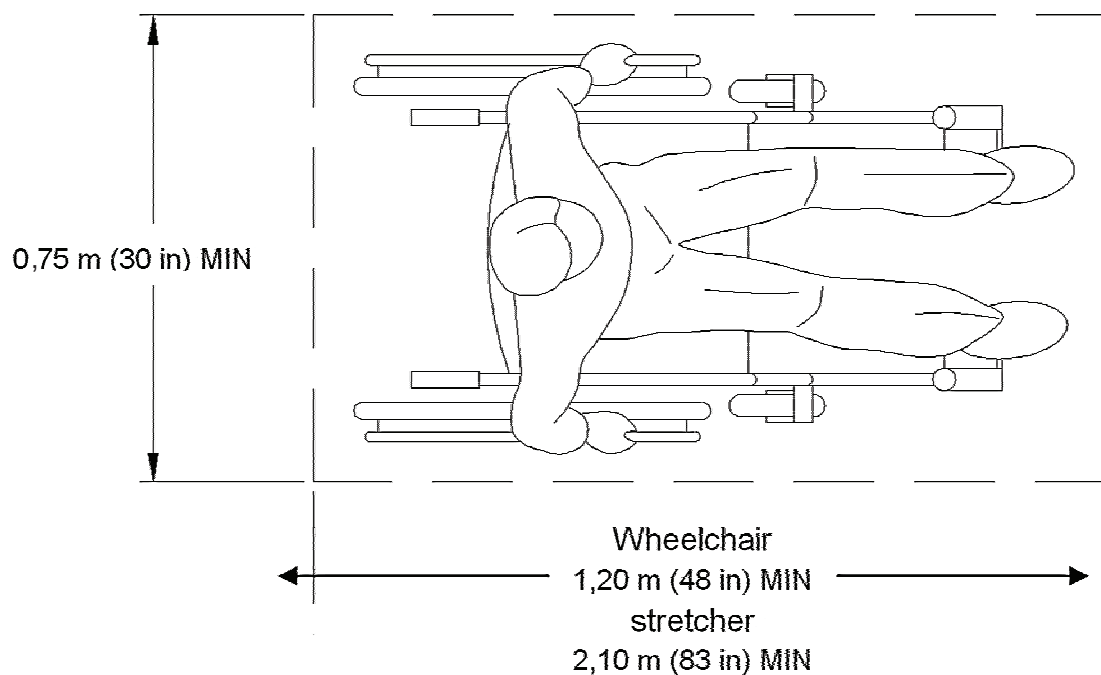

Figure A.1 — Clear floor space

A.2 Clear pathway

The minimum clear width of any pathway to be used by a wheelchair, including the boarding platform where intended, within a height range of 0,30 m (12 in) to 1,60 m (64 in) over the floor, shall be per [Figure A.2](#):

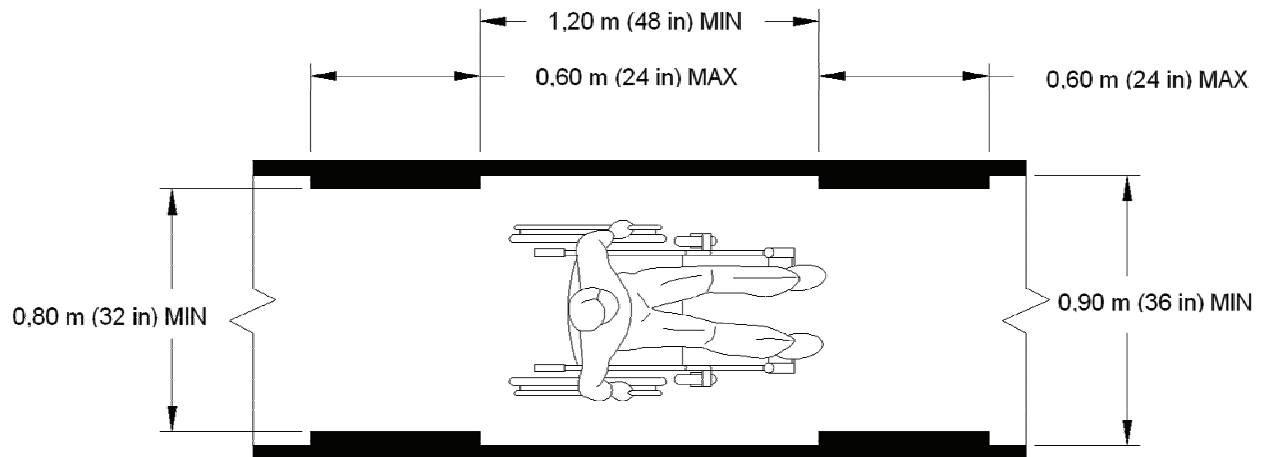

Figure A.2 — Clear pathway

A.3 Transfer plate

The requirements in [A.1](#) and [A.2](#) above do not apply to transfer plates used to bridge the aircraft door sill.

Bibliography

- [1] ISO 7176, *Wheelchairs*
- [2] ISO 9999, *Assistive products for persons with disability — Classification and terminology Society of Automotive Engineers (SAE) recommended practices¹⁾*
- [3] SAE/ARP 5140, *Design criteria for lifts used to board passengers with mobility impairments onto aircraft with door sill heights of 144 in or less*
- [4] SAE/ARP 5141A, *Design criteria for lifts used to board passengers with mobility impairments onto aircraft with door sill heights of more than 144 in* International Air Transport Association (IATA), *Airport Handling Manual (AHM), Section 9²⁾*
- [5] AHM 915, *Standard controls*
- [6] AHM 921, *Functional specification for incapacitated passenger loading vehicle*
- [7] AHM 921A, *Functional specification for incapacitated passenger loading vehicle with integrated driver's position* European Standards³⁾
- [8] EN 1915-1, *Aircraft ground support equipment — General requirements — Part 1: Basic safety requirements*
- [9] EN 1915-2, *Aircraft ground support equipment — General requirements — Part 2: Stability and strength requirements, calculations and test methods*
- [10] EN 1915-3, *Aircraft ground support equipment — General requirements — Part 3: Vibration measurement methods and reduction*
- [11] EN 1915-4, *Aircraft ground support equipment — General requirements — Part 4: Noise measurement methods and reduction*
- [12] EN 12312-14, *Aircraft ground support equipment — Specific requirements — Part 14: Disabled/incapacitated passenger boarding equipment* European Union legislation⁴⁾
- [13] E.U. Council Directive 2006/42/EC of 17 May 2006 on machinery, and amending Directive 95/16/EC
- [14] ISO/TR 22411, *Ergonomics data and guidelines for the application of ISO/IEC Guide 71 to products and services to address the needs of older persons and persons with disabilities*
- [15] IEC 60601-1-11, *Medical electrical equipment — Part 1-11: General requirements for basic safety and essential performance — Collateral standard: Requirements for medical electrical equipment and medical electrical systems used in the home healthcare environment*
- [16] EN 1756-2+A1, *Platform lifts for mounting on wheeled vehicles — Safety requirements — Part 2: Tail lifts for passengers [ISO equivalent not found, TBD]*
- [17] Regulation (EC) No. 1107-2006 of the European Parliament and of the Council of 5 July 2006 concerning *the rights of disabled persons and persons with reduced mobility when travelling by air*

-
- 1) Society of Automotive Engineers (SAE), 400 Commonwealth Drive, Warrendale PA, 15096-0001, USA.
 - 2) Publications Assistant, International Air Transport Association, 800 Place Victoria, P.O.Box 113, Montréal, Québec, Canada, H4Z 1M1.
 - 3) Comité Européen de Normalisation (CEN), Avenue Marnix 17, B-1000 Brussels, Belgium, or any of the European national Standards Institutes, member bodies of CEN.
 - 4) Official Journal of the European Communities (9.6.2006, pages L157/24 through L157/86), rue de la Loi 200, B-1049 Brussels, Belgium, available at info@publications.europa.eu.

- [18] United States Department of Transportation/Federal Aviation Administration (FAA) Advisory Circular (AC) No. 150/5220-21C, *Aircraft Boarding Equipment*

© ISO 2014. All rights reserved.

15845:2014