

INTERNATIONAL STANDARD

ISO 15785

First edition
2002-07-01

Technical drawings — Symbolic presentation and indication of adhesive, fold and pressed joints

*Dessins techniques — Représentation symbolique et indication des
assemblages collés, repliés et clinchés*



Reference number
ISO 15785:2002(E)

© ISO 2002

PDF disclaimer

This PDF file may contain embedded typefaces. In accordance with Adobe's licensing policy, this file may be printed or viewed but shall not be edited unless the typefaces which are embedded are licensed to and installed on the computer performing the editing. In downloading this file, parties accept therein the responsibility of not infringing Adobe's licensing policy. The ISO Central Secretariat accepts no liability in this area.

Adobe is a trademark of Adobe Systems Incorporated.

Details of the software products used to create this PDF file can be found in the General Info relative to the file; the PDF-creation parameters were optimized for printing. Every care has been taken to ensure that the file is suitable for use by ISO member bodies. In the unlikely event that a problem relating to it is found, please inform the Central Secretariat at the address given below.

© ISO 2002

All rights reserved. Unless otherwise specified, no part of this publication may be reproduced or utilized in any form or by any means, electronic or mechanical, including photocopying and microfilm, without permission in writing from either ISO at the address below or ISO's member body in the country of the requester.

ISO copyright office
Case postale 56 • CH-1211 Geneva 20
Tel. + 41 22 749 01 11
Fax + 41 22 749 09 47
E-mail copyright@iso.ch
Web www.iso.ch

Printed in Switzerland

Contents

Page

Foreword.....	iv
1 Scope	1
2 Normative references	1
3 Terms and definitions	1
4 Graphical symbols.....	2
5 Indication of joints in drawings.....	3
6 Basic conventions for symbolic presentation and indication of joints	4
7 Designation examples	5
Annex A (normative) Presentation and dimensions of graphical symbols	7

Foreword

ISO (the International Organization for Standardization) is a worldwide federation of national standards bodies (ISO member bodies). The work of preparing International Standards is normally carried out through ISO technical committees. Each member body interested in a subject for which a technical committee has been established has the right to be represented on that committee. International organizations, governmental and non-governmental, in liaison with ISO, also take part in the work. ISO collaborates closely with the International Electrotechnical Commission (IEC) on all matters of electrotechnical standardization.

International Standards are drafted in accordance with the rules given in the ISO/IEC Directives, Part 3.

The main task of technical committees is to prepare International Standards. Draft International Standards adopted by the technical committees are circulated to the member bodies for voting. Publication as an International Standard requires approval by at least 75 % of the member bodies casting a vote.

Attention is drawn to the possibility that some of the elements of this International Standard may be the subject of patent rights. ISO shall not be held responsible for identifying any or all such patent rights.

ISO 15785 was prepared by Technical Committee ISO/TC 10, *Technical product documentation*, Subcommittee SC 6, *Mechanical engineering documentation*.

Annex A forms a normative part of this International Standard.

Technical drawings — Symbolic presentation and indication of adhesive, fold and pressed joints

1 Scope

This International Standard establishes rules for the symbolic presentation and indication of adhesive, fold and pressed joints in technical drawings.

2 Normative references

The following normative documents contain provisions which, through reference in this text, constitute provisions of this International Standard. For dated references, subsequent amendments to, or revisions of, any of these publications do not apply. However, parties to agreements based on this International Standard are encouraged to investigate the possibility of applying the most recent editions of the normative documents indicated below. For undated references, the latest edition of the normative document referred to applies. Members of ISO and IEC maintain registers of currently valid International Standards.

ISO 128-20, *Technical drawings — General principles of presentation — Part 20: Basic conventions for lines*

ISO 128-22, *Technical drawings — General principles of presentation — Part 22: Basic conventions and applications for leader lines and reference lines*

ISO 128-24:1999, *Technical drawings — General principles of presentation — Part 24: Lines on mechanical engineering drawings*

ISO 129-1:—¹⁾, *Technical drawings — Indication of dimensions and tolerances — Part 1: General principles*

ISO 2553, *Welded, brazed and soldered joints — Symbolic representation on drawings*

ISO 3098-0:1997, *Technical product documentation — Lettering — Part 0: General requirements*

ISO 17659:2002, *Welding — Multilingual terms for welded joints with illustrations*

3 Terms and definitions

For the purposes of this International Standard, the terms and definitions given in ISO 128-22 and the following apply.

3.1 joint

junction of workpieces or edges of workpieces that are to be joined or have been joined

[ISO 17659:2002, definition 3.1]

1) To be published. (Revision of ISO 129:1985)

3.1.1

adhesive joint

joint of two or more parts of similar or different materials made using adhesives

3.1.2

fold joint

joint of two edges of surfaces of similar or different materials made by catching and coupling

3.1.3

pressed joint

joint of two or more parts of sheet materials made by simultaneous deformation from two sides by means of (cylindrical, rectangular etc.) tools

4 Graphical symbols

4.1 General

The joints specified in this International Standard are identified by the symbols shown in Figures 1 to 4.

The manner of presentation and the dimensions of these symbols are given in Annex A.

NOTE The symbols shown in Figures 1 to 3 are identical to those given in ISO 2553 for joints of identical configuration.

4.2 Adhesive joints

Adhesive joints shall be identified by the symbols shown in Figures 1 and 2.

A surface joint shall be identified by the symbol shown in Figure 1.



Figure 1 — Symbol for surface joint

An inclined joint shall be identified by the symbol shown in Figure 2.



Figure 2 — Symbol for inclined joint

4.3 Fold joint

A fold joint shall be identified by the symbol shown in Figure 3.

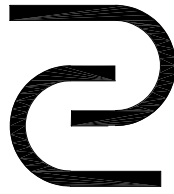

Figure 3 — Symbol for fold joint

4.4 Pressed joint

A pressed joint shall be identified by the symbol shown in Figure 4.



Figure 4 — Symbol for pressed joint

5 Indication of joints in drawings

The symbols shall be drawn using a continuous wide line in accordance with ISO 128-24 (see Figure 5 for an example), supplemented by the applicable information in accordance with ISO 2553.

The distance between the graphical symbol and the reference line shall be at least $2d$ (for d , see Annex A).

The leader line and reference line shall be drawn using a continuous narrow line in accordance with ISO 128-22.

The leader line shall end in an arrow (see Figure 5) and the reference line may begin with a fork (see Figure 6), where additional requirements may be indicated (see Figure 7).

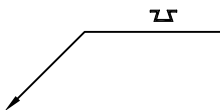

Figure 5 — Symbol with reference line and leader line

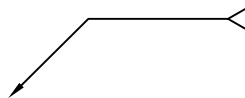

Figure 6 — Reference line with fork

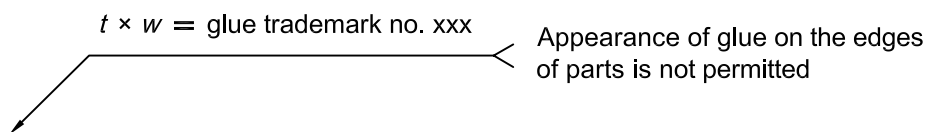

Figure 7 — Additional information with reference line

In addition to the symbol, the following may be indicated with the reference line, as necessary:

- a) the dimensions of the cross-section of the joint (width and height, punch diameter, depth of punching etc.), placed at left of symbol;
- b) other characteristics, for example, designations of the material, placed at right of symbol;
- c) additional requirements for the joint, placed in the fork (see Figure 7).

The dimensions that locate the joint shall be indicated in accordance with ISO 129-1.

6 Basic conventions for symbolic presentation and indication of joints

6.1 Adhesive joints

Adhesive joints shall be shown without an indication of the adhesive, as shown in Figures 8 and 9.

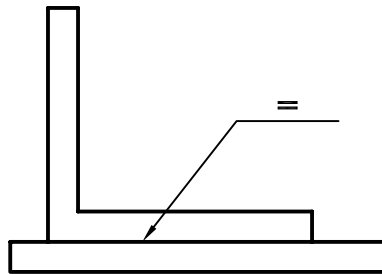

Figure 8 — Indication of surface joint

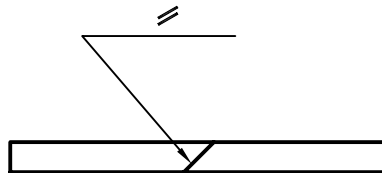

Figure 9 — Indication of inclined joint

To indicate a continuous adhesive joint formed around the periphery of a part, a circle shall be added at the intersection between the leader and reference lines in accordance with ISO 128-22 (see Figure 10).

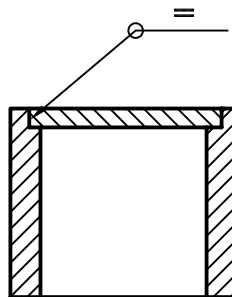

Figure 10 — Indication of joint around periphery

An adhesive joint limited to an area shall be indicated using a type 05.1.8 long-dashed double-dotted narrow line in accordance with ISO 128-24:1999 (see Figure 11).

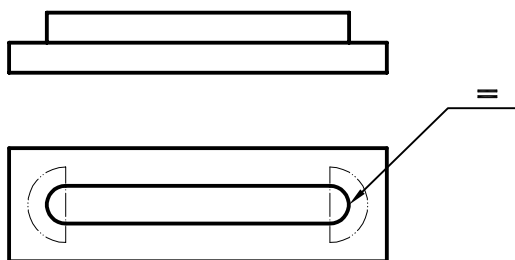

Figure 11 — Indication of limited area

6.2 Fold joints

Fold joints shall be presented in accordance with the general principles given in ISO 128-20, ISO 128-22 and ISO 128-24.

6.3 Pressed joints

If a joint is made by mechanical pressing in more than one place, the dimensions specifying the locations of the pressings shall be shown on the presentation of the parts being jointed (see Figure 12).

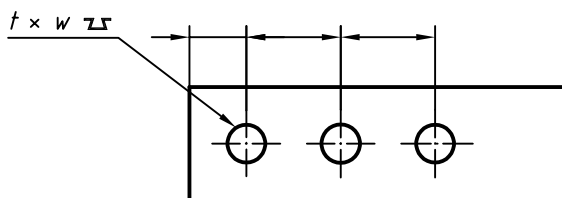
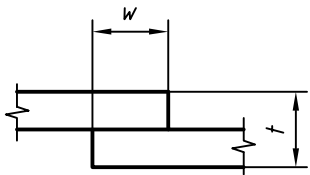
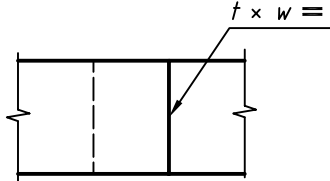
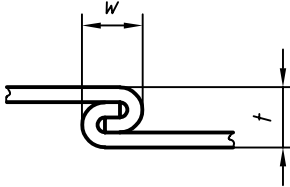
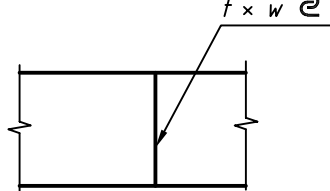
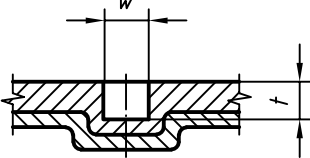
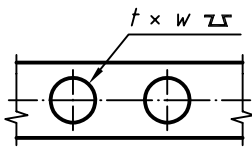

Figure 12 — Indication of pressed joint

7 Designation examples

Examples of designations are given in Table 1.

Table 1 — Designation examples

Type of connection	Presentation	Designation
Adhesive		
Fold		
Pressed		

Annex A
(normative)

Presentation and dimensions of graphical symbols

The presentation and dimensions of the graphical symbols shall be as shown in Figures A.1 to A.4.

The line width, d , for both graphical symbols and upright letters shall be

$$d = 0,1 h$$

where h is the lettering height according to ISO 3098-0:1997.

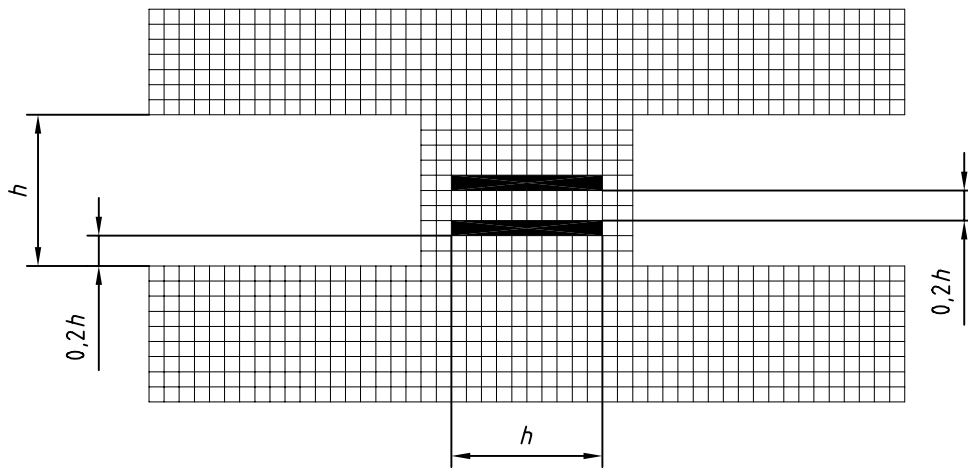

Figure A.1 — Adhesive joint — Surface joint

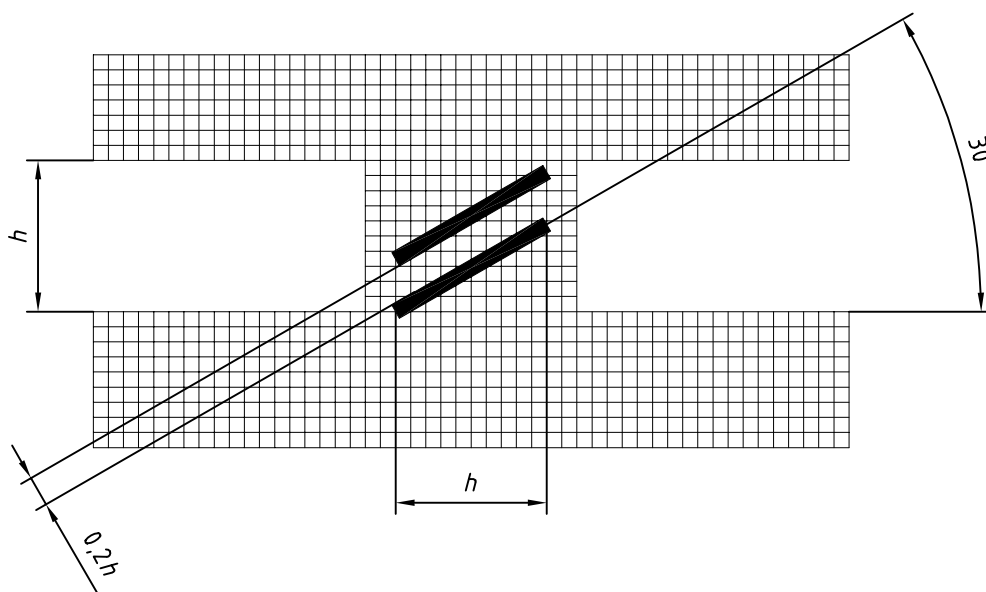

Figure A.2 — Adhesive joint — Inclined joint

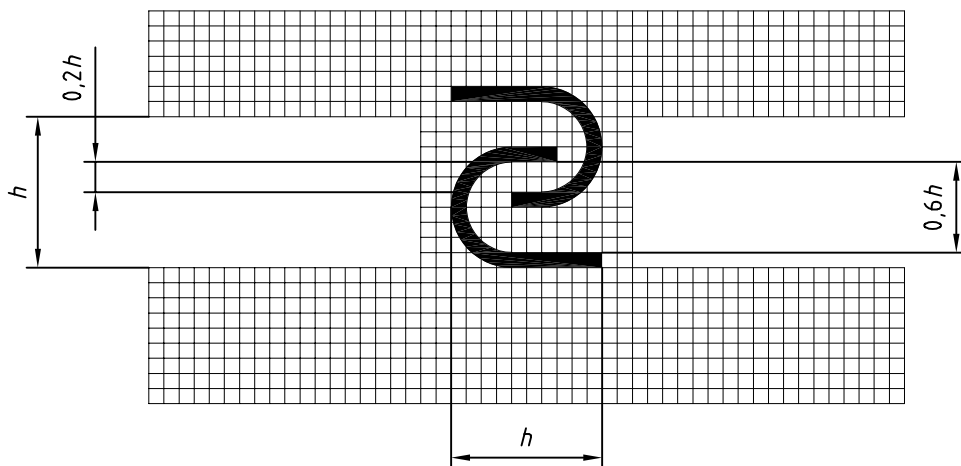

Figure A.3 — Fold joint

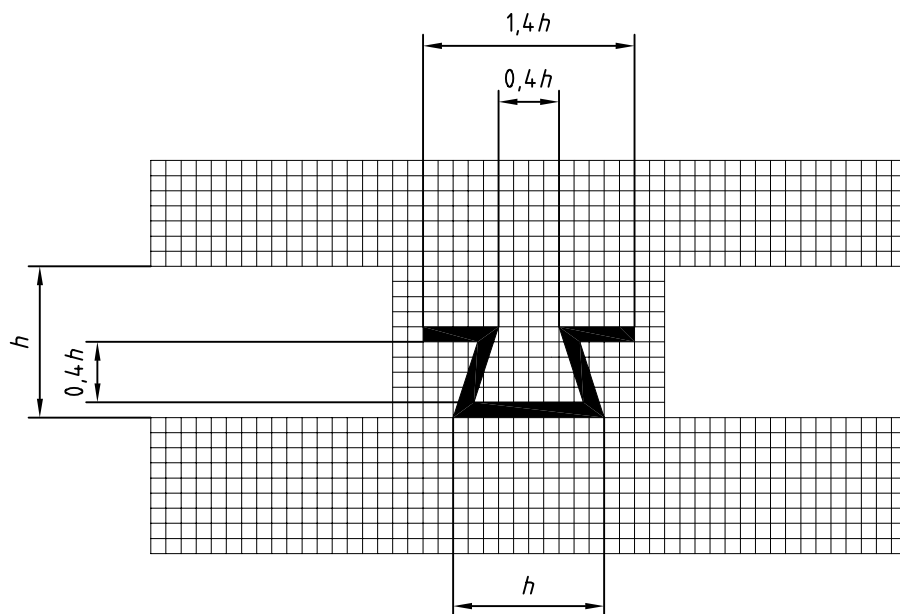
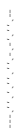

Figure A.4 — Pressed joint



ICS 01.100.20

Price based on 8 pages

© ISO 2002 – All rights reserved