

---

---

**Ships and marine technology —  
Drainage systems on ships and  
marine structures —**

**Part 3:  
Sanitary drainage, drain piping for  
vacuum systems**

*Navires et technologie maritime — Installations de drainage sur navires  
et structures maritimes —*

*Partie 3: Drainage sanitaire, conduits de décharge au système de vide*



Reference number  
ISO 15749-3:2004(E)

© ISO 2004

**PDF disclaimer**

This PDF file may contain embedded typefaces. In accordance with Adobe's licensing policy, this file may be printed or viewed but shall not be edited unless the typefaces which are embedded are licensed to and installed on the computer performing the editing. In downloading this file, parties accept therein the responsibility of not infringing Adobe's licensing policy. The ISO Central Secretariat accepts no liability in this area.

Adobe is a trademark of Adobe Systems Incorporated.

Details of the software products used to create this PDF file can be found in the General Info relative to the file; the PDF-creation parameters were optimized for printing. Every care has been taken to ensure that the file is suitable for use by ISO member bodies. In the unlikely event that a problem relating to it is found, please inform the Central Secretariat at the address given below.

© ISO 2004

All rights reserved. Unless otherwise specified, no part of this publication may be reproduced or utilized in any form or by any means, electronic or mechanical, including photocopying and microfilm, without permission in writing from either ISO at the address below or ISO's member body in the country of the requester.

ISO copyright office  
Case postale 56 • CH-1211 Geneva 20  
Tel. + 41 22 749 01 11  
Fax + 41 22 749 09 47  
E-mail [copyright@iso.org](mailto:copyright@iso.org)  
Web [www.iso.org](http://www.iso.org)

Published in Switzerland

# Contents

Page

<b>Foreword</b> .....	<b>iv</b>
<b>1 Scope</b> .....	<b>1</b>
<b>2 Normative references</b> .....	<b>1</b>
<b>3 Terms and definitions</b> .....	<b>2</b>
<b>4 Vacuum system</b> .....	<b>2</b>
<b>5 Pipes</b> .....	<b>3</b>
<b>6 Fittings</b> .....	<b>4</b>
<b>7 Laying of drain lines</b> .....	<b>5</b>
<b>8 Capacity of drain lines</b> .....	<b>7</b>
<b>9 Collector tank and sewage treatment plant</b> .....	<b>7</b>
<b>10 Determination of air capacity</b> .....	<b>8</b>
<b>11 Testing and operation of pipelines</b> .....	<b>9</b>
<b>12 Disposal</b> .....	<b>9</b>
<b>13 System example</b> .....	<b>9</b>
<b>Annex A (informative) Example of a cleaning direction within an operating instruction for the cleaning of a pipe system by pickling</b> .....	<b>11</b>
<b>Annex B (normative) Test methods</b> .....	<b>17</b>
<b>Bibliography</b> .....	<b>20</b>

## Foreword

ISO (the International Organization for Standardization) is a worldwide federation of national standards bodies (ISO member bodies). The work of preparing International Standards is normally carried out through ISO technical committees. Each member body interested in a subject for which a technical committee has been established has the right to be represented on that committee. International organizations, governmental and non-governmental, in liaison with ISO, also take part in the work. ISO collaborates closely with the International Electrotechnical Commission (IEC) on all matters of electrotechnical standardization.

International Standards are drafted in accordance with the rules given in the ISO/IEC Directives, Part 2.

The main task of technical committees is to prepare International Standards. Draft International Standards adopted by the technical committees are circulated to the member bodies for voting. Publication as an International Standard requires approval by at least 75 % of the member bodies casting a vote.

Attention is drawn to the possibility that some of the elements of this document may be the subject of patent rights. ISO shall not be held responsible for identifying any or all such patent rights.

ISO 15749-3 was prepared by Technical Committee ISO/TC 8, *Ships and marine technology*, Subcommittee SC 3, *Piping and machinery*.

ISO 15749 consists of the following parts, under the general title *Ships and marine technology — Drainage systems on ships and marine structures*:

- *Part 1: Sanitary drainage-system design*
- *Part 2: Sanitary drainage, drain piping for gravity systems*
- *Part 3: Sanitary drainage, drain piping for vacuum systems*
- *Part 4: Sanitary drainage, sewage disposal pipes*
- *Part 5: Drainage of decks, cargo spaces and swimming pools*

# Ships and marine technology — Drainage systems on ships and marine structures —

## Part 3: Sanitary drainage, drain piping for vacuum systems

### 1 Scope

This part of ISO 15749 applies to the design of sanitary drain lines in vacuum systems on ships and marine structures.

For planning and basic requirements, see ISO 15749-1.

### 2 Normative references

The following referenced documents are indispensable for the application of this document. For dated references, only the edition cited applies. For undated references, the latest edition of the referenced document (including any amendments) applies.

IMO Resolution A.753 (18), *Guidelines for the application of plastic pipes on ships*<sup>1)</sup>

ISO 65, *Carbon steel tubes suitable for screwing in accordance with ISO 7-1*

ISO 264, *Unplasticized polyvinyl chloride (PVC) fittings with plain sockets for pipes under pressure — Laying lengths — Metric series*

ISO 4200, *Plain end steel tubes, welded and seamless — General tables of dimensions and masses per unit length*

ISO 9329-1, *Seamless steel tubes for pressure purposes — Technical delivery conditions — Part 1: Unalloyed steels with specified room temperature properties*

ISO 9330-1, *Welded steel tubes for pressure purposes — Technical delivery conditions — Part 1: Unalloyed steel tubes with specified room temperature properties.*

ISO 15749-1, *Ships and marine technology — Drainage systems on ships and marine structures — Part 1: Sanitary drainage-system design*

ISO 15749-4, *Ships and marine technology — Drainage systems on ships and marine structures — Part 4: Sanitary drainage, sewage disposal pipes*

---

1) Published by International Maritime Organization, London.  
Available from IMO Secretariat, Publications Section, 101-104 Piccadilly, London W1V, United Kingdom.

### 3 Terms and definitions

For the purposes of this document, the terms and definitions given in ISO 15749-1 apply.

## 4 Vacuum system

### 4.1 Functional description

The vacuum drainage system operates as follows:

- wastewater is collected from water closets, urinals, and bidets or from other drainage items in branch lines or manifolds;
- the wastewater is carried by means of the vacuum to a wastewater collector tank or a sewage treatment plant.

The wastewater is evacuated in the form of a “plug” (sewage plug) owing to a pressure difference in the pipes before and behind the plug.

### 4.2 Description

**4.2.1** Drain lines in the vacuum system commence at the drain of a drainage item.

Vacuum-operated water closets have an integrated vacuum mechanism, other drainage items are connected to a separate vacuum valve via a short non-vacuum line.

Drain lines in the vacuum system terminate at a vacuum-generating unit.

**4.2.2** The wastewater is conveyed through pressure pipes from the vacuum generation unit to a collector tank or sewage treatment plant.

NOTE The vacuum-generating unit may also be integrated into the collector tank or sewage treatment plant.

**4.2.3** The sewage disposal pipes downstream of the collector tank or sewage treatment plant are not part of the vacuum system.

For the design of these and other pressure pipes, ISO 15749-4 is applicable.

Figure 2 of this standard shows an example of a vacuum-operated drainage system with drain lines.

**4.2.4** Depending on the ship type, its architecture, arrangement of ship's rooms and number of persons, one, two or more vacuum sewage systems, which serve separate sections of a ship, can be provided.

### 4.3 Operating pressure

The operating pressure is between 0,4 bar and 0,7 bar absolute pressure (corresponding to a permissible negative pressure of between – 0,3 bar and – 0,6 bar).

## 4.4 Drainage items

### 4.4.1 Vacuum-operated water closet

A water closet fitted with a mechanism for drain and flush valve control shall be provided.

The water volume for one flushing operation is approximately 1,2 litres.

#### 4.4.2 Urinals and bidets

These sanitary drainage items do not have built-in vacuum mechanisms and shall therefore be connected to a separate vacuum mechanism (vacuum valve) via connecting lines.

#### 4.4.3 Washbasins and other drainage items

These sanitary drainage items do not have built-in vacuum mechanisms and shall therefore be connected to a separate vacuum mechanism (vacuum valve) via connecting lines.

### 5 Pipes

Depending on the location, the following pipes shall be used for vacuum drain lines and vent lines:

- steel pipes in accordance with 5.1;
- steel pipes and CuNiFe pipes with spigot and socket joints, hereinafter referred to as spigot and socket pipes;
- CuNiFe pipes in accordance with 5.3;
- PVC-U pipes in accordance with 5.4; plastic pipes shall be approved in accordance with IMO-Resolution A.753 (18);
- pipes with low flame spread and smoke emission properties are at the discretion of the classification society.

For nominal bores see Table 1.

**Table 1 — Nominal bores for drain lines**

Type of pipe	Steel and CuNiFe pipes	PVC-U and spigot and socket pipes
Nominal bore, NB	40	40
	50	50
	100	—

#### 5.1 Steel pipes

The following types of pipes are applicable:

- seamless steel pipes in accordance with ISO 4200 and ISO 9329-1, of S 235 JR;
- welded steel pipes in accordance with ISO 4200 and ISO 9330-1, of S 235 JR;
- threaded pipes in accordance with ISO 65, of S 185.

For outside diameter and wall thickness see Table 2.

Table 2 — Dimensions of steel pipes

Nominal bore, NB	Outside diameter, $d$ mm	Wall thickness, $s_{\min}$ mm
40	48,3	2,3
50	60,3	2,3
100	114,3	3,2

## 5.2 Spigot and socket pipes

Spigot and socket pipes with dimensions in accordance with Table 3 are applicable. Also, CuNi10Fe1,6Mn pipes with these dimensions are applicable.

Table 3 — Dimensions of spigot and socket pipes

Nominal bore, NB	Outside diameter, $d$ mm	Wall thickness, $s_{\min}$ mm
40	42	1,4
50	53	1,4

## 5.3 CuNiFe pipes

CuNi10Fe1,6Mn pipes with dimensions in accordance with Table 4 are applicable.

Table 4 — Dimensions of CuNiFe pipes

Nominal bore, NB	Outside diameter, $d$ mm	Wall thickness, $s_{\min}$ mm
40	44,5	2
50	57	

## 5.4 PVC-U pipes

Pipes with dimensions in accordance with Table 5 are applicable.

Table 5 — Dimensions of PVC-U pipes

Nominal bore, NB	Outside diameter, $d$ mm	Wall thickness, $s_{\min}$ mm
40	50	3,7
50	63	4,7

# 6 Fittings

## 6.1 Requirements

Fittings shall be suitable for vacuum use in accordance with 4.3. Shut-off valves shall provide smooth passage.



## 6.2 Testing

Testing for tightness is specified in B.2.

## 7 Laying of drain lines

### 7.1 Line routing

In accordance with ISO 15749-1, vacuum drain lines may run in any direction. However, changes in direction at short intervals should be avoided.

### 7.2 Horizontal laying

#### 7.2.1 Gradient

Horizontally laid piping should have a slight gradient (approximately 2:1 000) towards the point of suction.

#### 7.2.2 Water traps

Water traps shall be integrated into horizontally installed pipes at distances of not more than 40 m, immediately before riser branches.

### 7.3 Connecting lines

Non-vacuum lines connecting drainage units to vacuum valves shall have an adequate gradient of not less than 2:1 000. Unimpeded supply with venting of the line, if required, shall be ensured.

### 7.4 Riser branches

**7.4.1** Not more than three vacuum toilets or vacuum valves may be connected to one riser branch, all of which shall be located on the same deck. The length of the riser branch shall not exceed one deck height (max. 3 m). Longer branches should be subject to the manufacturer's consent.

NOTE It is assumed that the max. three items will not be operated simultaneously.

**7.4.2** If only one vacuum toilet or vacuum valve is connected, the riser branches may pass through more than one deck, provided a horizontal conduit with a safety device against back flow is installed on each deck. See Figure 2.

**7.4.3** Immediately before the riser branch feeds into the horizontal manifold, a vacuum no-return fitting should be installed above the manifold, unless there is an elevation of the line of  $3 \times d$  at the inlet.

**7.4.4** If a collecting pipeline feeds into the horizontal manifold from above, a device preventing back flow should be installed just before the connection of a riser branch to the manifold.

### 7.5 Feeding pipes

The angle at which pipes feed into manifolds in the direction of flow shall not exceed 45°. Tees and 90° elbows may not be used. Connections from below, or located opposite to each other, are not permitted (see examples in Figure 1). The internal surface at the connections shall be smooth.

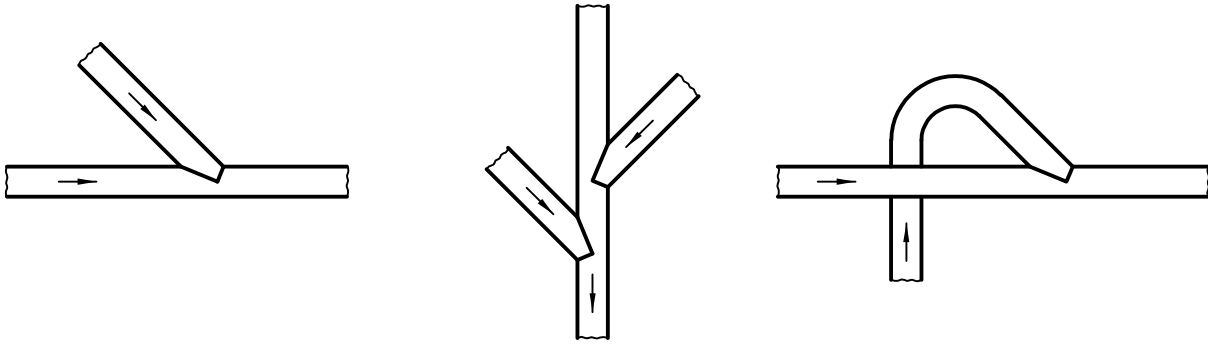

Figure 1 — Feeding pipes

## 7.6 Pipe elbows

The radius of bends in pipes shall not be less than three times the outer pipe diameter.

## 7.7 Cleaning openings

Cleaning openings shall be provided in pipe sections of drain lines which cannot be cleaned otherwise.

### 7.7.1 Cleaning openings in steel pipes

The following shall be provided:

- branch pipes with hex-head screw plugs; or
- blank flanges; or
- ball valves (arranged where frequent cleaning can be expected).

### 7.7.2 Cleaning openings in spigot and socket pipes

Suitable cleaning openings for vacuum pipes shall be provided.

### 7.7.3 Cleaning openings in PVC-U pipes

The following PVC-U moulded fittings for bonding shall be used:

- union-type adapter nipples in accordance with ISO 264;
- adapter bushings and threaded caps as closing devices.

### 7.7.4 Cleaning openings in CuNiFe pipes

The following shall be provided:

- branch pipes made of CuNiFe; or
- blank flanges; or
- ball valves.

## 8 Capacity of drain lines

### 8.1 Connections

For nominal bores of pipes and the number of vacuum mechanisms in drain lines, see Table 6.

**Table 6 — Dimensions of piping**

Pipes	Nominal bore, NB	Number of vacuum mechanisms <sup>a</sup>
Single branches	40	2
Collecting branches	50	2 to 32
Riser branches	40	1 to 3
Manifolds	50	32 max.
<sup>a</sup> Vacuum-operated water closets (with integrated mechanisms) and vacuum valves.		

One vacuum valve shall not serve more than two drainage items without vacuum mechanisms.

### 8.2 Manifolds

Systems with several vacuum mechanisms should be separated into at least two manifolds to save the function in case of blockage in one line.

In-line water closet systems installed in one room should be connected to two separate manifolds.

### 8.3 Main sewers

Manifolds which cannot be connected separately to a vacuum-generating unit shall be routed to a main sewer (or valve manifold).

Main sewers shall be designed so that they are as short as possible with a gradient towards the vacuum-generating unit.

If a main sewer is to serve more than six manifolds, it shall have a nominal bore of NB 100.

## 9 Collector tank and sewage treatment plant

Concerning details for the design of tanks and sewage treatment plants, the following shall be taken into account:

- the minimum volume of wastewater in accordance with to ISO 15749-1:2004, Table 2;
- if necessary, the volume differing from the minimum volume of wastewater;
- necessary or agreed, holding time of wastewater in tanks or sewage treatment plants depending on the ship's trading area;
- general requirements in accordance with ISO 15749-1.

## 10 Determination of air capacity

### 10.1 Air capacity for sewage

The air capacity for sewage  $P_1$  is determined on the basis of the following equation:

$$P_1 = W \times b_1 \times f_1 \times f_2 \tag{1}$$

where

$b_1$  is the air consumption, in litres, for one activation of a vacuum mechanism for sewage (usually 60 L);

$f_1$  is the number of water closet uses per hour (usual values, see Table 7);

$f_2$  is the factor for loss through system leakage (usually 1,25);

$P_1$  is the air capacity of sewage, in litres per hour;

$W$  is the number of water closets with integrated vacuum mechanisms and urinals with vacuum mechanisms connected.

**Table 7 — Number of water closet uses per hour ( $f_1$ )**

Type of vessel	Cargo vessel	Passenger ship	Ferry	Day excursion boat
$f_1$	5	6	7 to 9	12

### 10.2 Air capacity for grey water

The air capacity required for handling of grey water,  $P_2$ , is determined by means of equation (2). The values determined by means of this equation are not valid for certain areas of application, for example, vessels designed for one-day tourist excursions. In these cases, it is recommended to consult the manufacturer.

$$P_2 = \frac{K \times m \times b_2}{a \times n} + \frac{K \times m}{a} \tag{2}$$

where

$a$  is the number of peak periods (usually 2);

$b_2$  is the air consumption, in litres, for one activation of a vacuum mechanism for grey water (usually 50 L);

$K$  designates the number of persons<sup>2)</sup> whose grey water portion is discharged via vacuum-operated drain lines;

$m$  is the water consumption per person<sup>2)</sup> in 24 h, in litres (usually 60 L);

$n$  is the quantity of water handled due to one activation of a vacuum mechanism, in litres (usual 5 L or 15 L)<sup>3)</sup>;

$P_2$  is the air capacity of grey water, in litres per hour.

2) This number only refers to the number of persons for whom accommodation is available on board.

3) The usual design-related evacuation quantities.

## 11 Testing and operation of pipelines

For acceptance tests, leakage test, and information concerning the operation of the plant, see ISO 15749-1 and Annex B of this part of ISO 15749.

## 12 Disposal

For details concerning sewage disposal pipes downstream of collector tanks or sewage treatment plants, see ISO 15749-4.

## 13 System example

Figure 2 shows a simplified example of vacuum-operated drain lines leading to the collector tank or sewage treatment plant (here with integrated vacuum generation unit) as part of a sanitary drainage system.

For graphic symbols and simplified representations, see ISO 15749-1.

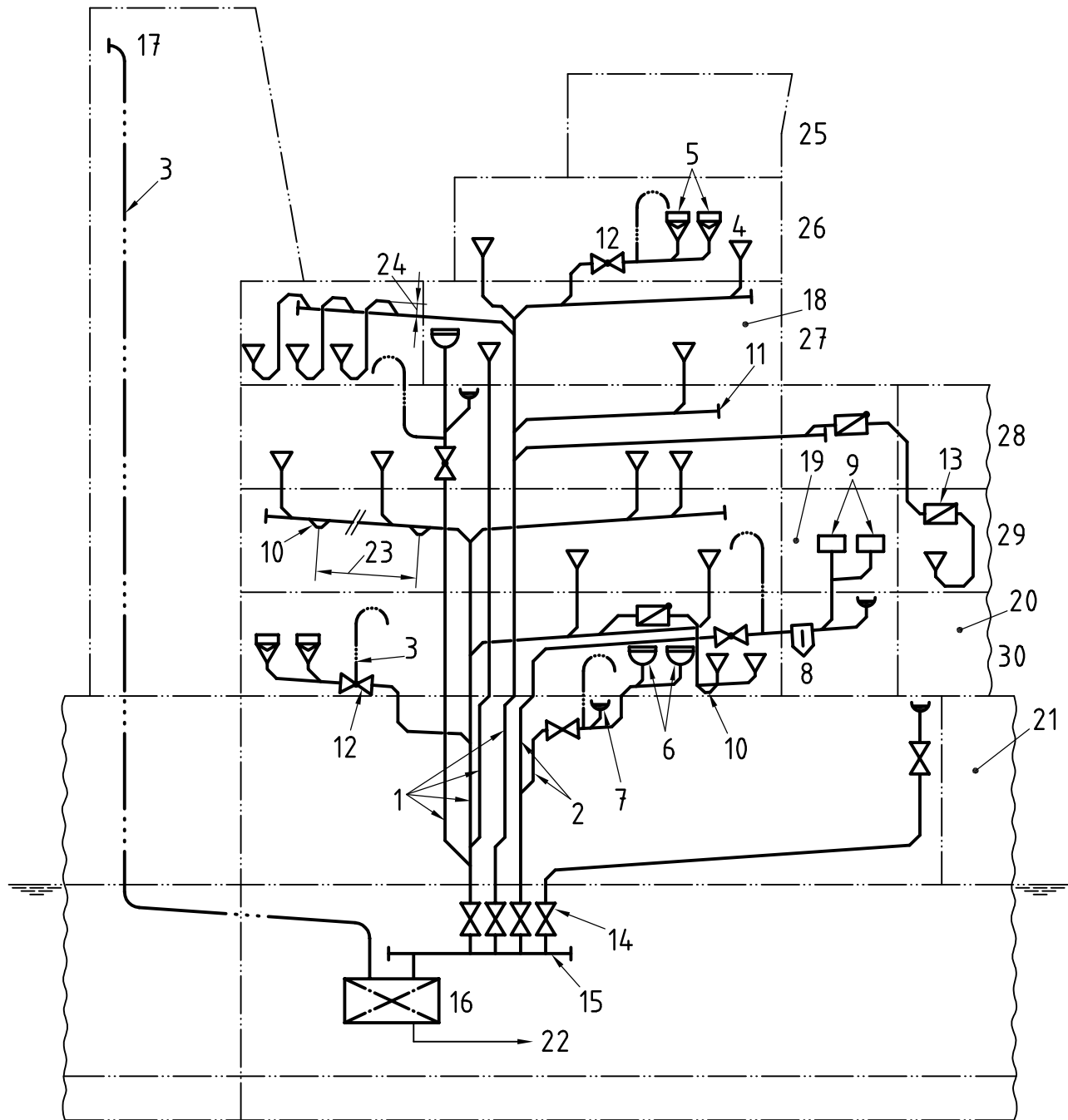

**Key**

- |    |                              |    |  |
|----|------------------------------|----|--|
| 1  | sewage system                | 16 | vacuum generation unit with collector tank |
| 2  | grey water system            | 17 | funnel                                     |
| 3  | vent line                    | 18 | hospital                                   |
| 4  | water closet (vacuum toilet) | 19 | galley                                     |
| 5  | urinal                       | 20 | provisions room                            |
| 6  | washbasin                    | 21 | hold                                       |
| 7  | drain with odour seal        | 22 | disposal in accordance with ISO 15749-4    |
| 8  | grease separator             | 23 | distance 30 m to 40 m                      |
| 9  | sink                         | 24 | 120 mm                                     |
| 10 | water trap                   | 25 | bridge                                     |
| 11 | cleaning closure             | 26 | 4 <sup>th</sup> superstructure deck        |
| 12 | vacuum valve                 | 27 | 3 <sup>rd</sup> superstructure deck        |
| 13 | vacuum non-return fitting    | 28 | 2 <sup>nd</sup> superstructure deck        |
| 14 | shut-off fitting             | 29 | 1 <sup>st</sup> superstructure deck        |
| 15 | valve manifold or main sewer | 30 | 1 <sup>st</sup> deck, freeboard/bulkhead   |

**Figure 2 — Example of a sanitary drainage system with vacuum-operated drain lines**

## Annex A (informative)

### Example of a cleaning direction within an operating instruction for the cleaning of a pipe system by pickling

**WARNING — Before starting with the pickling process, the pipeline system shall be checked for leakage.**

This tightness test is necessary as acid may leak from pipes which have been repaired only provisionally and cause damage to equipment.

The following acid may be used to clean the pipeline system .....

For neutralisation after cleaning the pipes use .....

**WARNING — Persons appointed for the cleaning shall be provided with appropriate protective equipment (e.g. gloves, protective goggles and protective clothes) because of the acidic effect of the chemicals used.**

**WARNING — It is pointed out that the disposal of cleaning liquids may be subject to the restrictions of the port state.**

If required, the acid to be used for the cleaning shall be diluted in accordance with the instructions.

The cleaning process shall be carried out in the following order.

**A.1** The line to be pickled (port or starboard) shall be closed by valves (1) and (2) (see Figures A.1 and A.2) and the vacuum generation unit shall be switched off.

**A.2** If there are no shut-off devices between the individual decks, the vacuum-water closets, excluding the water closets at the end of the line, shall be dismantled; the remaining openings shall be closed with plugs (4) (see Figure A.4). These plugs shall withstand the static pressure of the pipeline system to be filled.

**A.3** When shut-off fittings are installed, which close the pipelines on each deck against the pipes of the other decks then close the fittings (3), (4), (5), (6), (7) and (8) (see Figure A.3).

**A.4** The control line at the wastewater valve shall be separated from all water closets which are still connected with the pipeline system; the nipple shall be closed with a plug (see Figure A.5).

**A.5** The cleaning liquid (9) (see Figure A.3) shall be filled in the last water closet of the line to be cleaned (see A.3) and the discharge valve shall be opened by hand.

Fill up the line with cleaning liquid (9) until it remains in the bowl. With the arrangement as given in Figure A.4, the pipeline at the end of the line of each deck shall be vented by means of the plugs (4) in order to ensure that the pipe system is completely filled with the cleaning liquid.

**A.6** The cleaning liquid shall rest in the pipeline system for 24 h.

**A.7** After the time period according to A.6, switch on the vacuum-generating unit; open valves (1) to (8) and reinstall the control line at the water closets.

**A.8** Rinse the water closets three to four times. Start at the lowest deck and with the water closet next to the gravity delivery line [(sequence: 1st deck, 2nd deck, 3rd deck, etc. and closet 1, closet 2, closet 3, etc. (see Figure A.3)], to prevent blocking of the pipeline by loose scale.

**A.9** The procedure described in A.8 is not applicable for pipeline systems in accordance with Figure A.2. In that case, first, the pipeline system shall be ventilated through the plugs. The sequence described in A.8 shall be observed, i.e. starting with the first deck and at the beginning of the line. Close valves (1) and (2) and reinstall the water closets. Open valves (1) and (2) and rinse the water closets three to four times as stated in A.8.

**A.10** After rinsing, fill neutralisation fluid in the water closet at the end of the line of each deck and rinse.

The water/acid mixture in the collecting tank will thus be neutralised. The liquid in the collector tank shall be checked by an indicator paper before being pumped out of the collector tank.

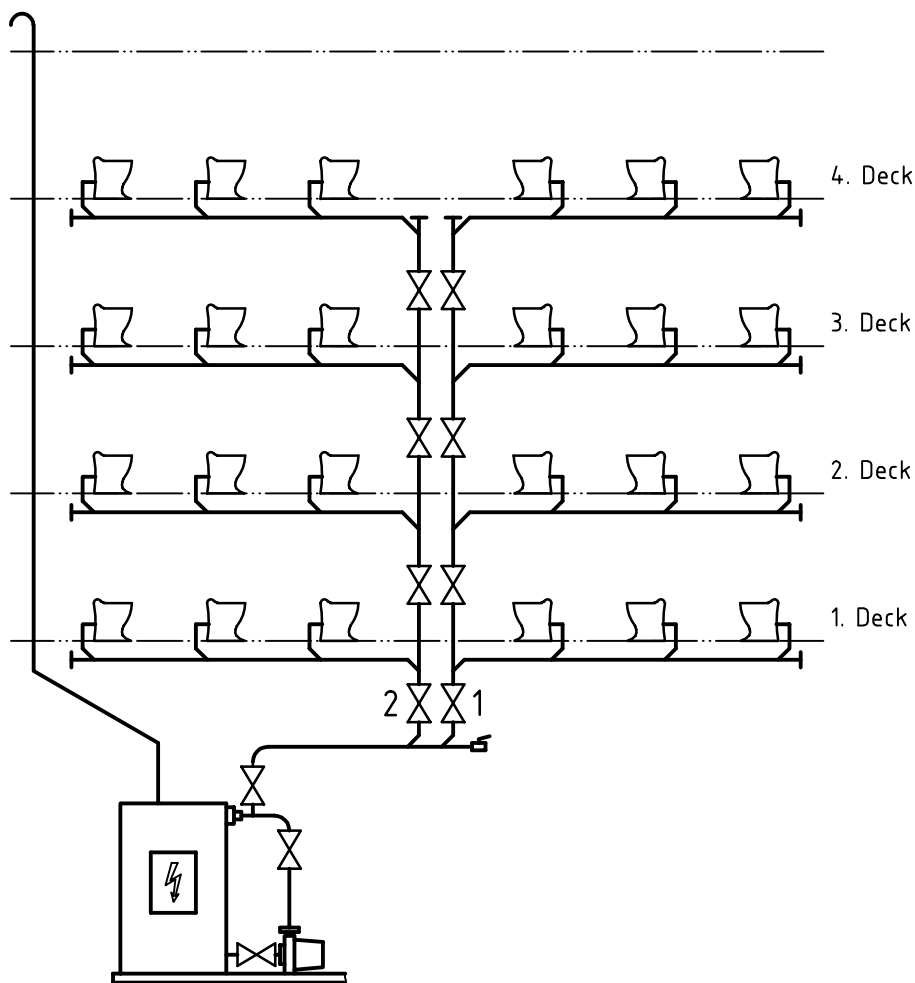

- Key**
- 1 valve – shut-off fitting
  - 2 valve – shut-off fitting

**Figure A.1 — Pipeline system with shut-off fittings between the decks**



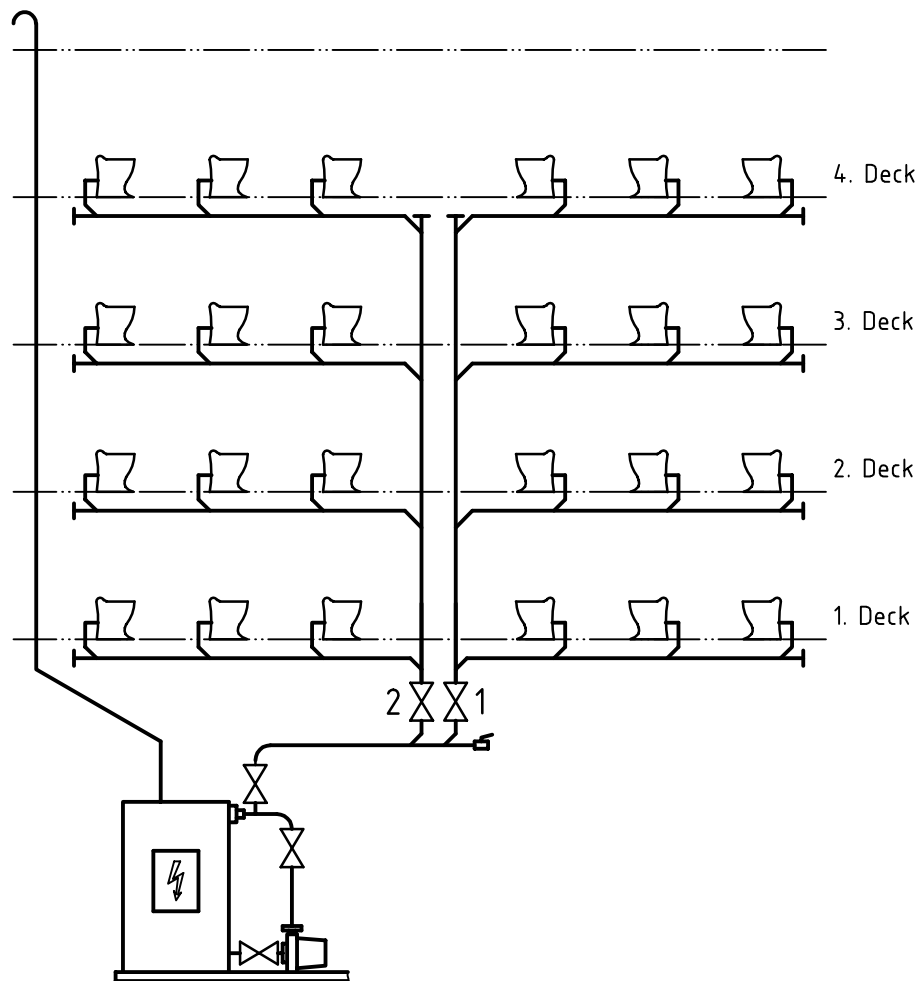

**Key**

- 1 valve – shut-off fitting
- 2 valve – shut-off fitting

**Figure A.2 — Pipeline system without shut-off fittings between the decks**

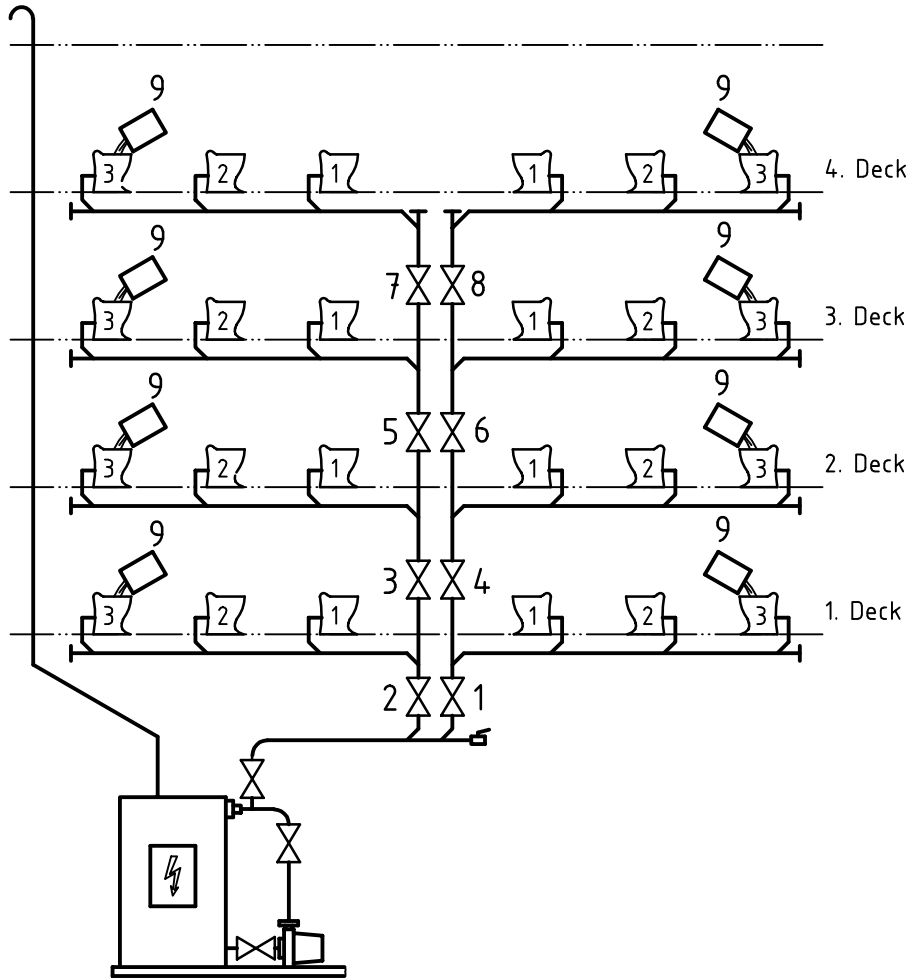

**Key**  
 1 to 8 valve – shut-off fitting  
 9 cleaning liquid

**Figure A.3 — Filling of acid and rinsing by a system according to Figure A.1**

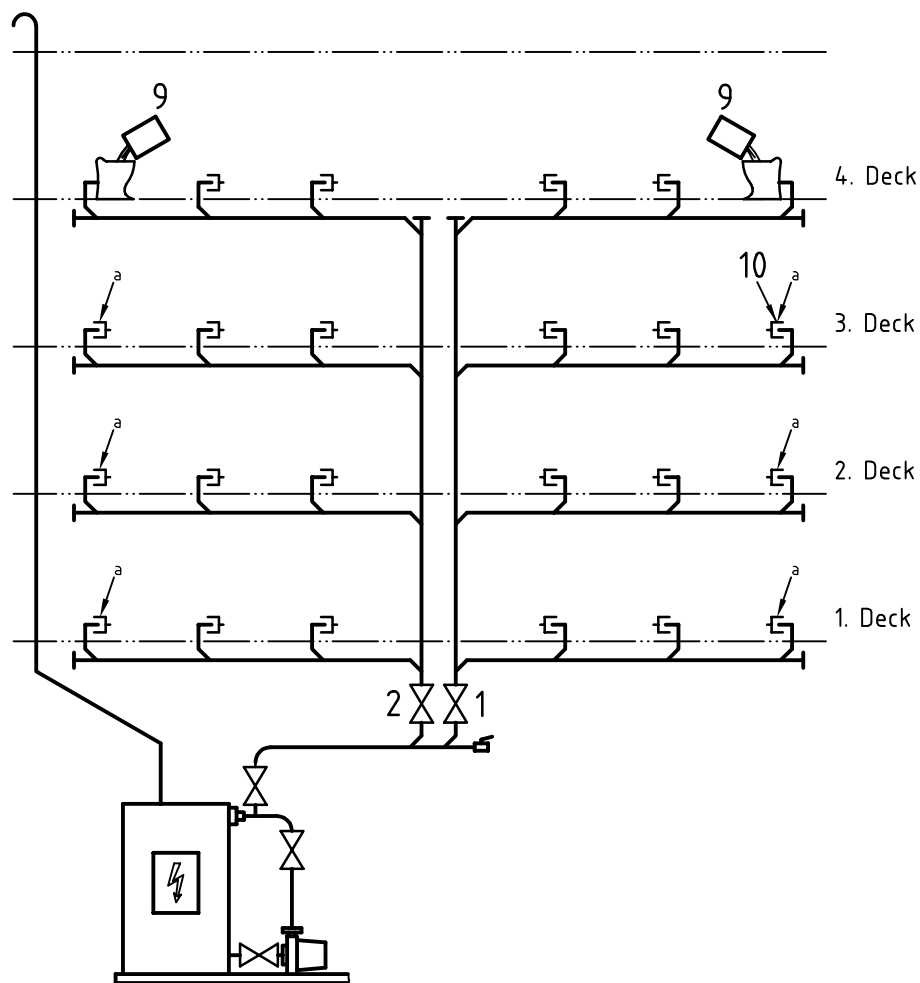

**Key**

- 1 valve – shut-off fitting
- 2 valve – shut-off fitting
- 9 cleaning liquid
- 10 plug
- a Acid.

**Figure A.4 — Filling of acid and rinsing by a system according to Figure A.2**

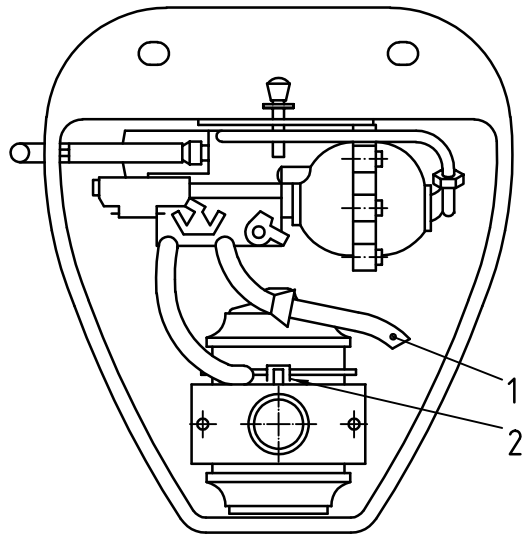

**Key**

- 1 control line
- 2 locking cap

**Figure A.5 — Vacuum-operated water closet**

## Annex B (normative)

### Test methods

#### B.1 General

The following tests shall be done when no other test specifications between the customer and contractor are agreed upon.

#### B.2 Leakage test

##### B.2.1 Test method

The whole pipeline system and/or parts of the system shall be tested in accordance with the following method.

- a) All openings shall be closed with appropriate plugs.
- b) The system or the part of the system to be tested shall be evacuated up to  $-80$  kPa (the pipe system shall be evacuated with a test pump).

##### B.2.2 Testing criteria

###### B.2.2.1 Final leakage test of the plant

The following has to be fulfilled.

- a) Having a system without connected evacuation valves, the vacuum shall not decrease by more than 10 kPa:
  - after a testing period of  $(180 \pm 2)$  min in systems with a low-pressure container;
  - after a testing period of  $(60 \pm 2)$  min in systems without a low-pressure container.
- b) After connecting the evacuation valves, before testing the system capacity, check whether there are severe operating faults (if necessary, replace the defective unit).

#### B.3 Testing of system capacity

##### B.3.1 Drainage of wastewater

With this test, a design flow and a minimum drainage shall be simulated at atmospheric pressure and temperature.

The system shall be at regular operational stand-by.

###### B.3.1.1 Test method

The following steps shall be applied.

- a) Determine the number of sanitary items within the whole system.
- b) Determine, for the whole system and in accordance with Table B.1, the number of sanitary items which shall drain wastewater at the same time.
- c) For testing, choose those sanitary items which are far away from the vacuum station. Choose sanitary items which are connected to different main sewers.
- d) The chosen sanitary items, such as washstands, kitchen sinks, bathtubs, etc. shall be filled with water until overflow. Bathtubs and washing machines, if present, shall be preferred to washstands, and dishwashers shall be preferred to kitchen sinks. Washing machines and dishwashers shall run with a full load.
- e) The test shall be carried out while the chosen sanitary items are drained at the same time and so that the automatic evacuation units operate at least three times by wastewater drainage. Vacuum closets shall be rinsed once.

**Table B.1 — Testing the power with drainage at the same time**

Ship type	Number of pieces of sanitary equipment at a main sewer	Number and type of simultaneously operated sanitary equipment	
		Vacuum closet	Other items
Cargo vessel	1 to 9	1	1
Passenger ship	1 to 9	1	1
	10 to 20	2	2
	21 to 32	3	2
Day excursion boat	1 to 9	1	1
	10 to 20	3	2
	21 to 32	5	3

**B.3.1.2 Testing criteria**

All sanitary items shall be drained completely and without damming-up in any equipment, irrespective of whether they have been drained individually or together.

No difference in operating behaviour of the sanitary items may occur, irrespective of whether they have been drained individually or together.

**B.3.2 Checking of vacuum in the lines**

**B.3.2.1 Test method**

The vacuum shall be controlled during testing the wastewater drainage according to B.3.1.

Connect a pressure gauge at the evacuation unit at the end of a line for which the highest static pressure loss may be expected and at the end of a line for which the highest flow may be expected. Pressure gauges existing at the vacuum station shall be used for testing.

**B.3.2.2 Testing criteria**

The vacuum shall be higher than the necessary vacuum for operating the evacuation unit.

### **B.3.3 Operation of the vacuum station**

#### **B.3.3.1 Power of vacuum producers and wastewater pumps**

The system shall be observed during all the above-mentioned tests. It shall be checked whether the capacity of the technical equipment is high enough for the system by controlling the operating time and the on-off values for the level of the wastewater and the vacuum.

All values shall correspond to the requirements of the invitation to tender.

#### **B.3.3.2 Control and monitoring systems of the vacuum station**

The test methods shall be harmonised for each system because the details of controlling and monitoring for each system are laid down individually.

The function at regular operation has to be tested by monitoring the control system during the tests in accordance with the following paragraph.

The ability of the system to recognise and indicate special malfunctions shall be checked by simulating these malfunctions in the equipment one by one, corresponding to the control logic and by observing and recording the response of the system (shut-down and alarm).

## Bibliography

- [1] ISO 727-1, *Fittings made from unplasticized poly(vinyl chloride) (PVC-U), chlorinated poly(vinyl chloride) (PVC-C) or acrylonitrile/butadiene/styrene (ABS) with plain sockets for pipes under pressure — Part 1: Metric series*





---

---

**ICS 47.020.30**

Price based on 20 pages