

---

---

**Steel for the reinforcement of concrete —  
Headed bars —**

**Part 2:  
Test methods**

*Aciers pour l'armature du béton — Barres avec platine d'ancrage —  
Partie 2: Méthodes d'essai*



Reference number  
ISO 15698-2:2012(E)

© ISO 2012



## COPYRIGHT PROTECTED DOCUMENT

© ISO 2012

All rights reserved. Unless otherwise specified, no part of this publication may be reproduced or utilized in any form or by any means, electronic or mechanical, including photocopying and microfilm, without permission in writing from either ISO at the address below or ISO's member body in the country of the requester.

ISO copyright office  
Case postale 56 • CH-1211 Geneva 20  
Tel. + 41 22 749 01 11  
Fax + 41 22 749 09 47  
E-mail [copyright@iso.org](mailto:copyright@iso.org)  
Web [www.iso.org](http://www.iso.org)

Published in Switzerland

# Contents

Page

Foreword .....	iv
<b>1 Scope .....</b>	<b>1</b>
<b>2 Normative references .....</b>	<b>1</b>
<b>3 Terms and definitions .....</b>	<b>1</b>
<b>4 Symbols .....</b>	<b>2</b>
<b>5 Load transfer tests .....</b>	<b>2</b>
<b>5.1 General .....</b>	<b>2</b>
<b>5.2 Testing machine .....</b>	<b>2</b>
<b>5.3 Testing procedure .....</b>	<b>3</b>
<b>5.4 Measurements and measurement equipment .....</b>	<b>3</b>
<b>5.5 Test set-up with the headed bar embedded in concrete .....</b>	<b>3</b>
<b>5.6 Test set-up with the headed bar in air .....</b>	<b>6</b>
<b>5.7 Anchorage capacity under static loading .....</b>	<b>7</b>
<b>5.8 Anchorage capacity under high-cycle elastic fatigue loading .....</b>	<b>9</b>
<b>5.9 Anchorage capacity under low-cycle elastic-plastic loading .....</b>	<b>11</b>
<b>6 Joint robustness tests .....</b>	<b>12</b>
<b>6.1 General .....</b>	<b>12</b>
<b>6.2 Wedge tensile test .....</b>	<b>12</b>
<b>6.3 Bend test .....</b>	<b>14</b>
<b>7 Test report .....</b>	<b>15</b>
<b>Bibliography .....</b>	<b>16</b>

## Foreword

ISO (the International Organization for Standardization) is a worldwide federation of national standards bodies (ISO member bodies). The work of preparing International Standards is normally carried out through ISO technical committees. Each member body interested in a subject for which a technical committee has been established has the right to be represented on that committee. International organizations, governmental and non-governmental, in liaison with ISO, also take part in the work. ISO collaborates closely with the International Electrotechnical Commission (IEC) on all matters of electrotechnical standardization.

International Standards are drafted in accordance with the rules given in the ISO/IEC Directives, Part 2.

The main task of technical committees is to prepare International Standards. Draft International Standards adopted by the technical committees are circulated to the member bodies for voting. Publication as an International Standard requires approval by at least 75 % of the member bodies casting a vote.

Attention is drawn to the possibility that some of the elements of this document may be the subject of patent rights. ISO shall not be held responsible for identifying any or all such patent rights.

ISO 15698-2 was prepared by Technical Committee ISO/TC 17, *Steel*, Subcommittee SC 16, *Steels for the reinforcement and prestressing of concrete*.

ISO 15698 consists of the following parts, under the general title *Steel for the reinforcement of concrete* — *Headed bars*:

- *Part 1: Requirements*
- *Part 2: Test methods*

# Steel for the reinforcement of concrete — Headed bars —

## Part 2: Test methods

### 1 Scope

This part of ISO 15698 specifies test methods applicable to headed steel bars to be used as reinforcement of concrete structures.

This part of ISO 15698 is intended to be applicable in relation to the various reinforced concrete design standards, as well as in relation to the various standards for steel reinforcing bars.

Testing of headed bars under impact loading is outside the scope of this part of ISO 15698.

### 2 Normative references

The following referenced documents are indispensable for the application of this document. For dated references, only the edition cited applies. For undated references, the latest edition of the referenced document (including any amendments) applies.

ISO 898-1, *Mechanical properties of fasteners made of carbon steel and alloy steel — Part 1: Bolts, screws and studs with specified property classes — Coarse thread and fine pitch thread*

ISO 1920-3, *Testing of concrete — Part 3: Making and curing test specimens*

ISO 1920-4, *Testing of concrete — Part 4: Strength of hardened concrete*

ISO 4965, *Axial load fatigue testing machines — Dynamic force calibration — Strain gauge technique*

ISO 6935-1, *Steel for the reinforcement of concrete — Part 1: Plain bars*

ISO 6935-2, *Steel for the reinforcement of concrete — Part 2: Ribbed bars*

ISO 7500-1, *Metallic materials — Verification of static uniaxial testing machines — Part 1: Tension/compression testing machines — Verification and calibration of the force-measuring system*

ISO 9513, *Metallic materials — Calibration of extensometers used in uniaxial testing*

ISO 15630-1, *Steel for the reinforcement and prestressing of concrete — Test methods — Part 1: Reinforcing bars, wire rod and wire*

ISO 15698-1:2012, *Steel for the reinforcement of concrete — Headed bars — Part 1: Requirements*

ISO 16020, *Steel for the reinforcement and prestressing of concrete — Vocabulary*

ISO 22965-2, *Concrete — Part 2: Specification of constituent materials, production of concrete and compliance of concrete*

### 3 Terms and definitions

For the purposes of this document, the terms and definitions given in ISO 15698-1 and ISO 16020 apply.

## 4 Symbols

For the purposes of this document, the symbols in Table 1 apply.

**Table 1 — Symbols**

Symbol	Unit	Designation
$D_{H,max}$	mm	The head's major dimension (ISO 15698-1)
$N$	-	Specified number of load cycles in axial load fatigue test
$R_{eH,spec}$	MPa	Specified characteristic (or nominal) yield strength value of the reinforcing bar
$d$	mm	Nominal diameter of the reinforcing bar
$2\sigma_a$	MPa	Stress range for high-cycle elastic fatigue loading test
$\sigma_{max}$	MPa	Maximum stress in axial load fatigue test
$\sigma_{min}$	MPa	Minimum stress in axial load fatigue test
$l_b$	mm	Required bond length for the reinforcing bar
$c$	mm	Concrete cover to the bar head
$c_d$	mm	Clearance between reinforcing bar and wedge hole
$b$	mm	Width of concrete specimen
$h_a$	mm	Height of concrete specimen type a
$h_b$	mm	Height of concrete specimen type b
$\alpha_A$	-	Aspect ratio between the minor and the major head dimension (ISO 15698-1)
$\delta$	mm	Anchor head movement
$w$	mm	Clearance between supports

1 MPa = 1 N/mm<sup>2</sup>

## 5 Load transfer tests

### 5.1 General

This clause specifies methods for testing the capability of transmitting a specified force to the surrounding concrete through headed reinforcing bars and to determine anchorage characteristics. The tests are tensile tests, intended for the verification of:

- size and shape of head bearing area;
- stiffness of the anchorage;
- strength of the head-to-bar connection in realistic conditions;
- required additional bond length and the composite action of head and bond (for heads of Category B1 only).

The tests are intended for qualification testing of headed reinforcing bars in order to determine the category to which they belong. The test with the head embedded in concrete is not limited to failure in the head-to-bar connection or in the bar itself, but does also include the surrounding concrete with respect to crushing or excessive non-elastic deformation.

All tests shall be carried out on headed bars produced or assembled in the same manner as they are prepared for normal use in construction. Each test shall comprise a minimum of three specimens.

### 5.2 Testing machine

The testing machine shall be verified and calibrated in accordance with ISO 7500-1 and shall be of class 1 or better, or of a corresponding class in accordance with an equivalent recognized standard.

The force range of the testing machine shall be suitable for the expected failure force of the test piece.

The test with the specimen embedded in concrete and the test in air may be carried out vertically or horizontally depending on the testing machine. All four sides of the concrete specimen have to be visible.

### 5.3 Testing procedure

The specimen shall be placed on the bearing plate, provided with a central hole, of the tension device as specified below. The tension force shall be applied to the protruding end of the reinforcing bar.

During the testing of concrete specimens, cracks in the concrete surface shall be observed and recorded.

If the test specimen fails in the gripping zone, and the head-to-bar connection is still intact, the test may be continued after re-gripping the test specimen.

### 5.4 Measurements and measurement equipment

The following measurements shall be taken:

- a) the applied force shall be measured with an accuracy of  $\pm 1\%$  or better;
- b) the strain in the reinforcing bar shall be measured with an accuracy of  $\pm 5\%$  or better and additionally for the concrete test specimens;
- c) the head displacement shall be measured by an extensometer of Class 1 or better according to ISO 9513, or of a corresponding class in accordance with an equivalent recognized standard.

The strain in the reinforcing bar shall be measured according to ISO 15630-1 or an equivalent recognized standard.

The results shall be recorded.

### 5.5 Test set-up with the headed bar embedded in concrete

#### 5.5.1 Geometry and set-up

The concrete test specimen shall be a prism of concrete where the headed bar is located in the centre of the prism. The headed bar shall consist of the full cross-section of the bar as-rolled with a head attached to one end of the reinforcing bar and cast into the concrete prism. The concrete prism shall have a square cross-section. The specimen shall be placed in the testing machine as shown in Figure 1. The specimen shall be supported concentrically with the longitudinal axis of the reinforcing bar. The free end of the reinforcing bar, without a head attached, shall be gripped by the testing machine.

For heads of Categories B2 and B3, the test set-up shown in Figure 1 a) applies. The reinforcing bar is provided with a plastic tube or similar, in order to prevent bond and allow the full applied force to be anchored by the head.

For heads of Category B1, a portion ( $l_b$ ) of the bar, corresponding to the required bond length shall be embedded in concrete. The remaining embedded portion of the reinforcing bar shall be provided with a plastic tube or similar.

For heads of Category B1, the surface geometry of the reinforcing steel to be tested shall be described in terms of surface condition (rust, etc.) and relative rib area in accordance with ISO 6935-2 and measured in accordance with ISO 15630-1. All the parameters required for calculating the relative rib area (or relative indentation area) shall be measured and recorded.

The tube shall fit with a clearance of about 1 mm around the bar and its thickness shall not exceed 2 mm.

In order to measure the head displacement (i.e. stiffness of the anchorage) and indicate possible crushing, a steel pin shall be attached to the bar head. The steel pin shall protrude out of the concrete surface as shown in Figure 1 and be provided with a plastic tube or similar in order to prevent bond to the concrete.

The dimensions of the test specimens are given in Table 2.

Table 2 — Test specimen dimensions in mm <sup>a</sup>

Bar diameter	$d$	16	20	25	28	32	40	50	57
Width of concrete specimen (both sides)	$b$	290	300	350	370	400	450	500	530
Height of concrete specimen type a	$h_a$	360	400	450	470	500	600	680	750
Height of concrete specimen type b	$h_b$	$h_a + h_b$							
Concrete cover to bar head	$c$	40							
<sup>a</sup> The dimensions for other diameters may be found by interpolation and extrapolation.									

NOTE The experience of testing bars with diameters larger than 32 mm is limited. To use the test method for such large diameters, a type testing programme should be performed to evaluate the applicability of the test method. Note that the specimens weigh from about 85 kg to about 500 kg.

The concrete test specimen shall be supported and gripped in the testing equipment in such a way that the load is transmitted axially and, as much as possible, free of any bending moment.

The concrete test specimen shall be provided with reinforcement in order to prevent premature splitting of the specimen. The reinforcement shall consist of straight small-diameter reinforcing bars positioned crosswise at both sides of the headed bar evenly distributed over the distance  $b$  from the head downwards. The total necessary reinforcement at each side and in each direction is given in Table 3.

Table 3 — Reinforcement in the concrete test specimen <sup>a</sup>

Headed bar diameter	mm	16	20	25	28	32	40	50	57
Reinforcement at each side and in each direction	mm <sup>2</sup>	100	150	200	250	390	560	800	1 000
Recommended maximum reinforcing bar size	mm	8	8	8	8	10	12	16	16
<sup>a</sup> Intermediate values may be found by interpolation.									

NOTE The necessary confinement reinforcement is based on a specimen with a Grade 500 headed bar with a maximum tensile strength of 775 MPa (upper region) and an allowable stress in the confinement reinforcement of 200 MPa. The total amount of confinement reinforcement is four times the values in Table 3.

If splitting of the concrete specimen occurs, the test may be repeated with an amount of splitting reinforcement increased to a feasible amount, just enough to avoid splitting. The new amount of reinforcement shall be stated in the test report.



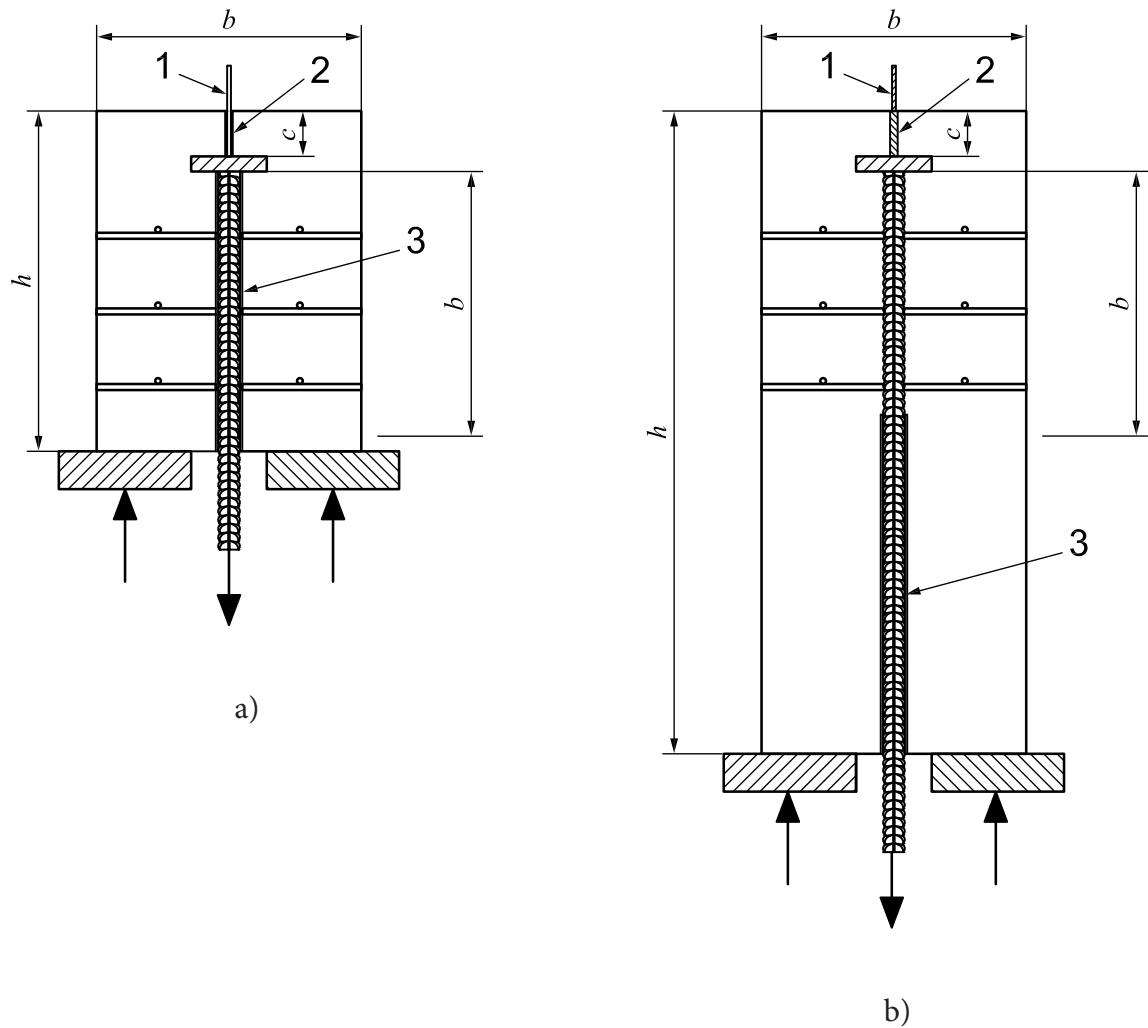

### Key

- 1 pin for measurement of head displacement
- 2 sleeve for prevention of bond
- 3 sleeve for prevention of bond
- $h$  height of specimen
- $b$  width of specimen in both directions
- $c$  concrete cover to head

Figure 1 — Set-up for testing with heads embedded in concrete

### 5.5.2 Concrete material and making of the concrete test specimen

The manufacturer shall specify the concrete strength of the test specimen.

The concrete shall be made of well-graded aggregates with a maximum aggregate size of 16 mm. Compaction is carried out to the same degree as for the cubes or cylinders used for the control of the strength of concrete.

The concrete strength shall be verified by cylinders or cubes from the same batch and tested at the same age as the concrete test specimen. The concrete strength shall be determined according to ISO 1920-4 and classified according to ISO 22965-2.

The making and curing of the concrete test specimens shall be performed according to ISO 1920-3 or an equivalent recognized standard to the extent that the requirements are relevant and not in conflict with this part of ISO 15698. The test shall preferably be executed after 28 days.

The concrete test specimen shall be cast upside down (i.e. the bar shall be vertical with the head at the bottom of the mould, see Figure 1) in rigid moulds that are capable of providing concrete test specimens with the dimensions and tolerances that conform to this part of ISO 15698. The moulds shall be watertight and shall be non-absorbent.

The placing and compaction of concrete and the surface levelling, marking and curing of the concrete test specimens shall be carried out in accordance with ISO 1920-3.

The following tolerances apply:

- 1) the tolerance on the width,  $b$ , shall be  $\pm 5\%$ ;
- 2) the tolerance on the height,  $h_a$  or  $h_b$ , shall be  $\pm 5\%$ ;
- 3) the tolerance on the perpendicularity of the bar axis with reference to the base (i.e. load bearing surface) shall be  $\pm 0,75^\circ$ ;
- 4) The tolerance on the flatness of the load-bearing surface shall be  $\pm 1,0$  mm.

NOTE The tolerances are defined according to ISO 1920-3.

## 5.6 Test set-up with the headed bar in air

### 5.6.1 General

This clause specifies an alternative method for testing the capability of transmitting a specified force from the bar to the head when the suitability of the head for transmitting the force into concrete is already verified. The method may be used if the conditions given in ISO 15698-1:2012, 7.2.1 are met. The test is a tensile test, intended for the verification of the strength of the head-to-bar connection in approximately realistic conditions.

### 5.6.2 Test set-up

The specimen shall be placed vertically with the head bearing area on the bearing plate, provided with a central hole, of the tension device. The size and shape of the hole depends on the head size and shape as given below, see Figure 2. The tension force shall be applied to the protruding end of the reinforcing bar.

- a) Square head: A circular hole with diameter  $D_c = 0,72$  times the head side length
- b) Rectangular head: A circular hole with diameter  $D_c = (0,52 + 0,2\alpha_A) \cdot D_{H,max}$ , where  $\alpha_A$  is the head aspect ratio and  $D_{H,max}$  is the larger side length of the head (see ISO 15698-1:2012, 6.1).
- c) Circular head: A circular hole with diameter  $D_c = 0,69$  times the head diameter

NOTE The size and the shape of the bearing plate hole is designed so that the line load along the edge of the hole produces approximately the same bending stresses in the head as when the head bearing area is exposed to a uniformly distributed load.

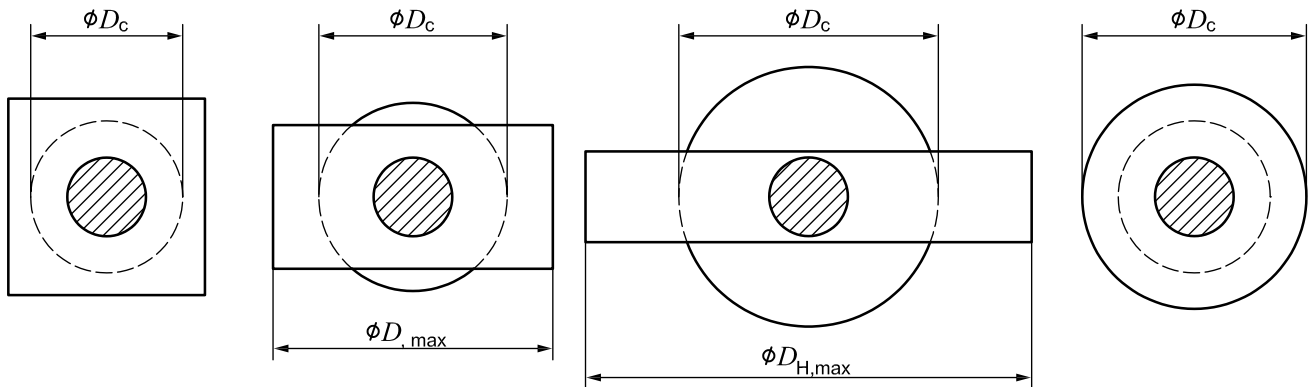

Figure 2 — Examples of head support holes

For oblong heads with aspect ratio less than 0,5 (i.e. with predominantly one-way bending) two linear supports with a clearance of  $w = 0,55D_{H,max}$  may be used as indicated in Figure 3.

## 5.7 Anchorage capacity under static loading

### 5.7.1 General

The purpose of the static loading test is to verify the static anchorage capacity of the headed bar. The testing procedure is applicable for both testing of the headed bar embedded in concrete and for optional testing in air.

The principle of the test in concrete is to load the anchorage part of a headed bar that is incorporated in a concrete prism by a tensile force. The relation between the tensile force and the relative displacement between head and concrete surface is measured up to failure. The force is increased up to failure. The principle of the test is illustrated in Figure 1.

The principle of the test in air is that the size of the hole will allow slight bending of the head similar to an embedded head with uniformly distributed concrete contact pressure. The principle of the test is illustrated in Figure 2, Figure 3 and Figure 4.

NOTE It is impossible to achieve exactly the same moment for all cases, it is just an approximation.

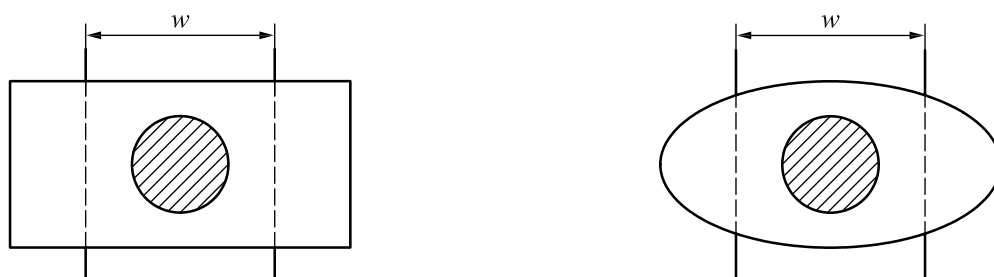

#### Key

$w$  clearance between supports

Figure 3 — Optional head support for heads with aspect ratio less than 0,5

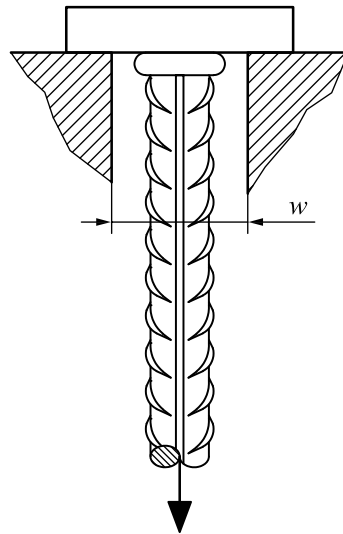

Figure 4 — Test set-up for load transfer test in air

### 5.7.2 Test procedure

The load shall be applied monotonically at a loading rate that corresponds to approximately 10 MPa/s steel bar stress increase.

The head displacement shall be measured continuously.

When testing in concrete, it shall be permissible that specimens of all categories be pre-loaded up to  $0,9 \cdot R_{eH,spec}$  and released a number of times, in order to stabilize the head-to-concrete interaction before the specimen is exposed to static loading and head displacement is determined.

**NOTE** By starting the test by pre-loading the specimen a number of times, some concrete deformation will be accumulated and the loading to failure will, thus, be executed in a more realistic manner (see Figure 5). The required number is to be assessed by the test laboratory. Normally 10 cycles should be sufficient. Too many cycles is assumed not to improve the results.

### 5.7.3 Test results

When testing in concrete, applied force vs. the bar head displacement shall be plotted (see Figure 5). Significant non-proportional displacement may indicate the beginning of concrete crushing in the head bearing zone, i.e. when the curve indicates a significant loss of stiffness. If the force cannot be increased any more, i.e. the force-displacement curve is horizontal, the attained force shall be considered as the anchorage capacity of the specimen. As long as the force can be increased, the loading shall continue until failure of the bar or head-to-bar joint.

If the load-displacement curve does not give a clear indication whether concrete crushing has taken place or not, the concrete test specimen shall be cut through the middle plane in order to identify any concrete crushing in the head bearing zone.

**NOTE** Incipient crushing of the concrete will normally be seen on the load-deformation curve as a loss of stiffness in terms of significantly increased head displacement. The magnitude of non-proportional displacement depends on a number of parameters. The most important ones are the type and grade of concrete, the bar steel grade, the head size and shape. Figure 5 shows a sample graph with bar break without concrete crushing. The specimen is grade C35/40 normal density concrete and a headed bar with grade 500 bar and a net head bearing area of six times the bar cross-section. The failure displacement is, in this case, exceeding the linear elastic displacement by about 10 %. No concrete crushing was observed, even with a 10x-scope.

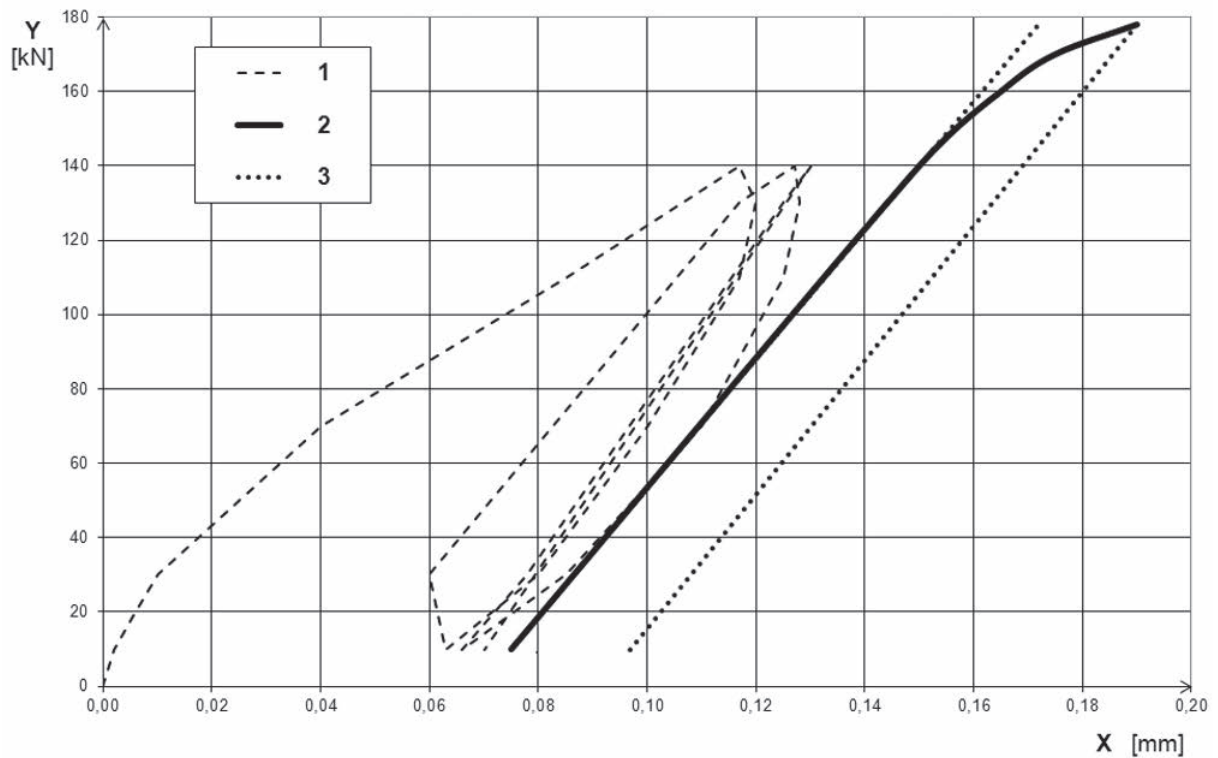

### Key

- 1 pre-loading (first 3 cycles)
- 2 loading (after 15 cycles of pre-loading)
- 3 theoretical linear force-displacement
- X displacement (mm)
- Y force (kN)

**Figure 5 — Typical force-displacement curve for normal density concrete**

## 5.8 Anchorage capacity under high-cycle elastic fatigue loading

### 5.8.1 General

The purpose of the high-cycle elastic fatigue test is to verify the fatigue anchorage capacity of the headed bar. The testing procedure is applicable for both testing of the headed bar embedded in concrete and for optional testing in air.

The fatigue performance of a headed bar will either be lower than that of the parent bar (Category F1) or equal to the parent bar (Category F2). The purpose of the fatigue testing of headed bars is to verify the fatigue strength of the headed bar, including the fatigue performance of the concrete in the head bearing zone, and determine the category in which it belongs.

**NOTE 1** The head size and design will influence the fatigue performance of the concrete in the head bearing zone. As few headed bars have been tested for high cycle fatigue in concrete, there is currently little experience with the various types of heads on the market.

In the fatigue test, the test specimen shall be subject to an axial pull-out load which varies cyclically according to a sinusoidal wave-form of constant frequency in the elastic range.

The tests shall be performed at two stress ranges with an upper stress level ( $\sigma_{\max}$ ) of  $0,6 R_{eH, \text{spec}}$ . A minimum of three test pieces at each stress range shall be tested, amounting to a total of six tests.

The stress ranges selected shall be such that the results can be compared to the S-N curve of the parent bar at the upper and lower part of the curve (see Figure 7).

NOTE 2 Unless otherwise stated, a low stress range  $2\sigma_a$  of  $0,2 R_{eH,spec}$  and a high stress range  $2\sigma_a$  of  $0,5 R_{eH,spec}$  is recommended.

**5.8.2 Testing equipment**

The fatigue test shall be carried out under load control by means of a hydraulic ram operated by a programmable closed-loop servo-controlled system.

The fatigue-testing machine when testing both in concrete and in air shall be calibrated according to ISO 7500-1 and ISO 4965. The accuracy shall be  $\pm 1\%$  or better, and the machine shall be capable of maintaining the upper stress level  $\sigma_{max}$  within  $\pm 2\%$  of the specified value and the lower stress level  $\sigma_{min}$  within  $\pm 2\%$  of the specified value.

**5.8.3 Test procedure**

The frequency of load cycles shall be maintained constant during the test and also during the test series. The frequency shall be no more than 200 Hz.

For heads embedded in concrete, the head displacement shall be measured continuously, or at least, the concrete test specimen shall be cut through the middle plane at the end of the test, in order to identify any concrete crushing in the head bearing zone.

When testing in concrete, it shall be permissible that specimens of all categories be pre-loaded up to  $0,6 \cdot R_{eH,spec}$  and released a number of times in order to stabilize the head-to-concrete interaction before the specimen is exposed to fatigue loading and head displacement is determined.

The temperature of the test piece shall not exceed  $40\text{ }^\circ\text{C}$  throughout the test. The temperature in the testing laboratory shall be between  $18\text{ }^\circ\text{C}$  and  $30\text{ }^\circ\text{C}$ .

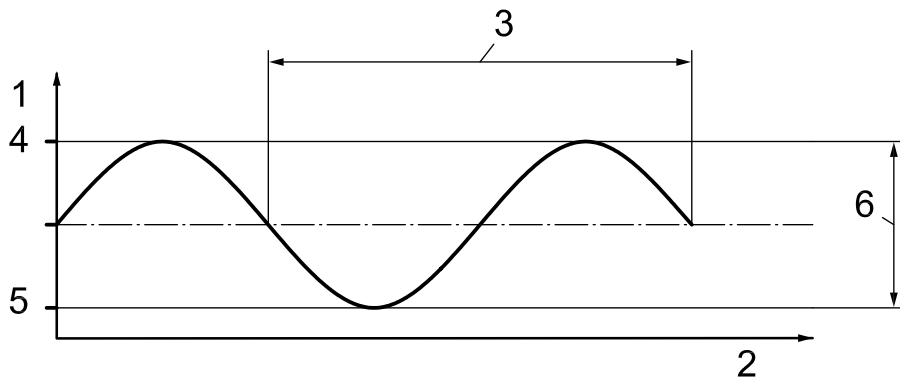

- Key**
- 1 stress
  - 2 time
  - 3 load cycle
  - 4 upper stress level ( $\sigma_{max}$ )
  - 5 lower stress level ( $\sigma_{min}$ )
  - 6 stress range ( $2\sigma_a$ )

**Figure 6 — Load cycle diagram**

The test is terminated upon fracture of the headed bar, crushing of the concrete in the head bearing zone or upon reaching a specified number of cycles without fracture. Concrete crushing (i.e. significant loss of stiffness) shall be considered as fracture.

NOTE Loss of stiffness is indicated when the angle of the force-displacement curve is decreasing.

#### 5.8.4 Test results

For concrete specimens, the bar head movement vs. applied force shall be plotted in order to determine any concrete crushing underneath the bar head.

If the load-displacement curve does not give a clear indication whether concrete crushing has taken place or not, the concrete test specimen shall be cut through the middle plane in order to identify any concrete crushing in the head bearing zone.

The number of cycles to failure for all the test specimens shall be recorded and compared with the corresponding value of the S-N diagram of the parent reinforcing bar (see Figure 7).

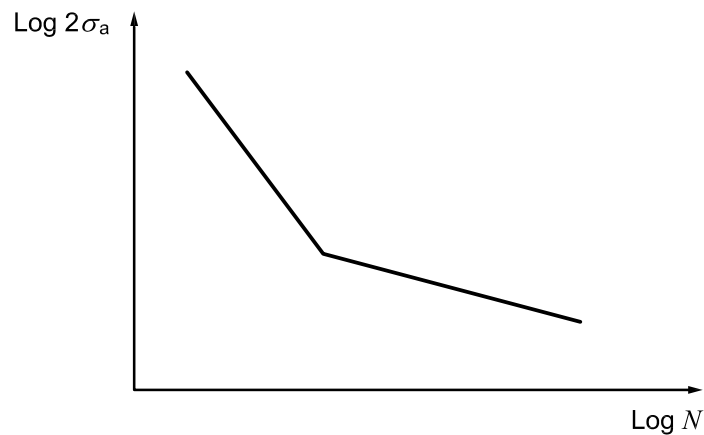

Figure 7 — Typical S-N diagram

### 5.9 Anchorage capacity under low-cycle elastic-plastic loading

#### 5.9.1 General

The purpose of the low-cycle elastic-plastic testing of headed bars is to determine the resistance to earthquake loading of the headed bar, including the performance of the concrete in the head bearing zone, and verify that it belongs to Category S. The testing procedure is applicable for testing of the headed bar embedded in concrete only.

NOTE The head size and design may influence the performance under low-cycle elastic-plastic loading of the concrete in the head bearing zone. As hardly any headed bars have been tested for low-cycle elastic-plastic loading in concrete yet, there is currently practically no experience with the various types of heads on the market.

In the low-cycle elastic-plastic test, the test piece is subject to an axial tensile load which varies cyclically into the plastic range.

#### 5.9.2 Test procedure

The concrete test specimen shall be loaded according to the loading programme given in ISO 15698-1.

The head displacement shall be measured continuously.

The test is terminated upon fracture of the headed bar, crushing of the concrete in the head bearing zone or upon reaching the specified number of cycles without fracture. Concrete crushing (i.e. significant loss of stiffness) shall be considered as fracture.

NOTE Loss of stiffness is indicated when the angle of the force-displacement curve is decreasing.

### **5.9.3 Test results**

The bar head movement vs. applied force shall be plotted in order to determine any concrete crushing underneath the bar head.

If the load-displacement curve does not give a clear indication whether concrete crushing has taken place or not, the concrete test specimen shall be cut through the middle plane in order to identify any concrete crushing in the head bearing zone.

The position of the failure and the failure mode shall be included in the test report.

## **6 Joint robustness tests**

### **6.1 General**

The robustness tests are part of the qualification testing.

The alternative tests are:

- wedge tensile test;
- bend test.

The manufacturer may decide the type of testing to be used, if not specified by the purchaser.

NOTE For some types of headed bars, the bend test is not suitable and, thus, the wedge tensile test is the only option.

### **6.2 Wedge tensile test**

#### **6.2.1 General**

Tensile test specimens shall be the full cross-section of the bar as rolled with a head attached to one end. The minimum length of the test specimen shall be at least ten times the nominal diameter of the bar and at least long enough to provide proper gripping. The test shall be based on the principles of wedge loading of full-size bolts and screws in ISO 898-1, as far as applicable.

The wedge tensile test shall be performed in accordance with the requirements specified in ISO 15698-1. The wedge angle used in the test shall be stated in the test report.

A maximum tolerance deviation  $\Delta\beta = -0,5^\circ$  is permitted.



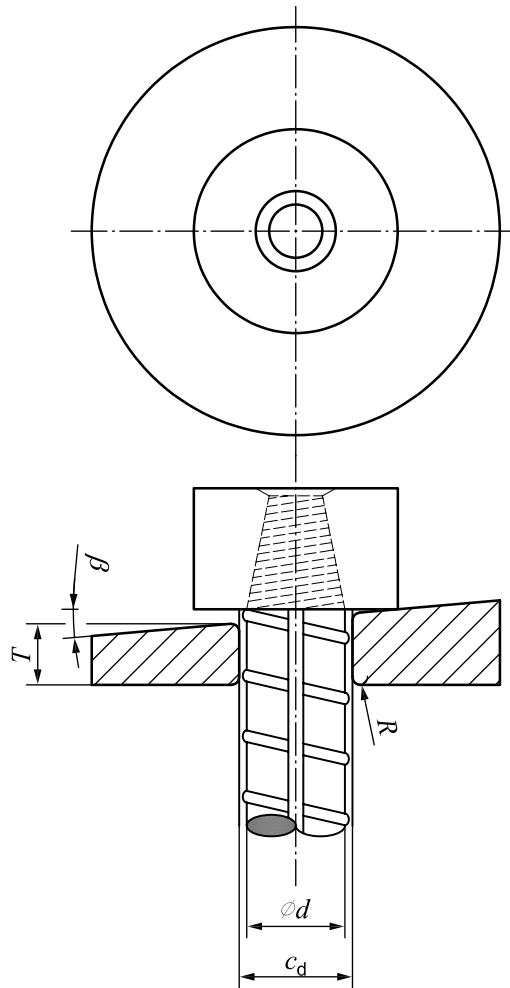

#### Key

- $c_d$  clearance of wedge hole
- $R$  chamfer radius
- $d$  nominal diameter of bar or sleeve where relevant
- $T$  thickness of wedge at short side of hole
- $\beta$  wedge angle

Figure 8 — Wedge tensile test set-up

#### 6.2.2 Test set-up

A specimen with a head attached to one end shall be placed in the testing machine with the head supported by a wedge shaped steel plate as shown in Figure 8. The diameter of the wedge shall be minimum  $1,2D_{H,max}$ . The wedge shall be made of hardened steel with a hardness of a minimum of 45 HRC. The wedge angle  $\beta$  shall be according to the required type of test as specified in ISO 15698-1. The thickness of the wedge at the short side of the hole shall equal at least one-half of the nominal diameter of the bar. The clearance  $c_d$  of the wedge hole shall be sufficient to allow the bar — or the sleeve where applicable — to move freely in the hole without any friction between the specimen and the inside of the hole. The wedge shall be placed concentrically with the longitudinal axis of the headed bar, directly against the inner surface of the head. Provisions shall be made for clearance between the support and any weld or forming material on the bar-to-head connection. Non-bearing material which conflicts with the wedge hole shall be removed. The free end of the reinforcing bar, without a head attached, shall be gripped by the testing machine.

For testing of double-headed bars, an open wedge hole may be used. Both heads may be tested at the same time.

### 6.2.3 Test procedure

Tensile testing of the headed bar assembly shall be performed in accordance with the specified requirements described in ISO 15698-1.

### 6.2.4 Test results

To meet the requirements of Category B3, the fracture shall occur in the parent reinforcing bar outside the affected zone.

In the case of Categories B1 and B2, other failure modes are permitted. The headed bar shall meet the requirements for minimum tensile strength for the appropriate category given in ISO 15698-1.

## 6.3 Bend test

### 6.3.1 General

The object of the bend test is to expose the head-to-bar intersection to high tensile strain in order to reveal any defects. The test is an optional part of the qualification testing.

### 6.3.2 Test set-up

Bend test specimens shall be the full cross-section of the bar as rolled with a head attached to one end of the reinforcing bar. The minimum length of the test specimen shall be such that it is possible to bend the bar at least 90°.

Before testing, the test specimen shall be prepared by removing head material on one side of the bar as shown on Figure 9 in order to allow contact between the mandrel and the head-to-bar intersection.

The test equipment shall be provided with mandrel, support and carrier as described in ISO 15630-1 (support and carrier not shown in Figure 8). The mandrel diameters are given in ISO 15698-1:2012, 7.3.3.

**NOTE** For nominal diameters larger than 32 mm, the performance of bend tests may have serious safety issues for the personnel involved in performing bend tests. For these bar diameters, the bend test may be replaced with the wedge tensile test.

### 6.3.3 Test procedure

The test specimen shall be bent around the mandrel to an angle of at least 60°. The test shall be carried out at a temperature between 10 °C and 35 °C.

### 6.3.4 Test results

There shall be no cracks visible to a person with normal or correct vision in the head, the bar, or the head-to-bar connection.

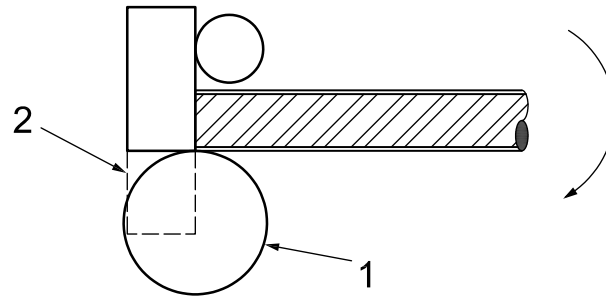
**Key**

- 1 bend test mandrel
- 2 removed head material

**Figure 9 — Bend test specimen and mandrel configuration**

## 7 Test report

The laboratory shall issue a report which shall contain the following information:

- a) identification of the laboratory;
- b) identification of the manufacturer of the product tested;
- c) product designation;
- d) steel grade and ductility class of the reinforcing steel bar with reference to ISO 6935 or other recognized standard;
- e) type of reinforcing steel and steel mill;
- f) relative rib area (if Category B1);
- g) number of this part of ISO 15698 and type of test method;
- h) nominal bar diameters and head dimensions tested;
- i) strength class of the concrete;
- j) concrete cylinder compressive strength at the date of testing and the age of the test specimen;
- k) main parameters of the test set-up, such as  $l_b$ ,  $c$  and  $b$  and increased amount of splitting reinforcement, if relevant;
- l) dates of the tests;
- m) all test results;
- n) description of the failure modes;
- o) the category or subcategory that is verified.

## Bibliography

- [1] ISO 10474, *Steel and steel products – Inspection documents*

.....

.....

---

---

**ICS 77.140.15**

Price based on 16 pages