**Road construction and maintenance
equipment — Soil stabilizers —
Terminology and commercial
specifications**

*Équipement pour la construction et l'entretien des routes —
Stabilisateurs de sol — Terminologie et spécifications commerciales*



Reference number
ISO 15688:2012(E)

© ISO 2012



COPYRIGHT PROTECTED DOCUMENT

© ISO 2012

All rights reserved. Unless otherwise specified, no part of this publication may be reproduced or utilized in any form or by any means, electronic or mechanical, including photocopying and microfilm, without permission in writing from either ISO at the address below or ISO's member body in the country of the requester.

ISO copyright office
Case postale 56 • CH-1211 Geneva 20
Tel. + 41 22 749 01 11
Fax + 41 22 749 09 47
E-mail copyright@iso.org
Web www.iso.org

Published in Switzerland

Contents

Page

Foreword	iv
Introduction	v
1 Scope	1
2 Normative references	1
3 Terms and definitions	1
4 Types and configuration of soil stabilizers	2
4.1 Types.....	2
4.2 Configuration.....	2
4.3 Tool driving principle.....	2
5 Commercial specifications	2
5.1 General.....	2
5.2 General data.....	2
5.3 Dimensional characteristics.....	3
5.4 Mass and load characteristics.....	4
5.5 Engine characteristics.....	4
5.6 Characteristics and type of wheels/crawlers.....	5
5.7 Traction transmission characteristics.....	5
5.8 Working and travelling speeds.....	5
5.9 Steering characteristics.....	6
5.10 Characteristics of the mixing devices.....	6
5.11 Equipment.....	9
Annex A (informative) Examples of soil stabilizer types, tools and dimensional characteristics	13
Bibliography	18

Foreword

ISO (the International Organization for Standardization) is a worldwide federation of national standards bodies (ISO member bodies). The work of preparing International Standards is normally carried out through ISO technical committees. Each member body interested in a subject for which a technical committee has been established has the right to be represented on that committee. International organizations, governmental and non-governmental, in liaison with ISO, also take part in the work. ISO collaborates closely with the International Electrotechnical Commission (IEC) on all matters of electrotechnical standardization.

International Standards are drafted in accordance with the rules given in the ISO/IEC Directives, Part 2.

The main task of technical committees is to prepare International Standards. Draft International Standards adopted by the technical committees are circulated to the member bodies for voting. Publication as an International Standard requires approval by at least 75 % of the member bodies casting a vote.

Attention is drawn to the possibility that some of the elements of this document may be the subject of patent rights. ISO shall not be held responsible for identifying any or all such patent rights.

ISO 15688 was prepared by Technical Committee ISO/TC 195, *Building construction machinery and equipment*.

This second edition cancels and replaces the first edition (ISO 15688:2003), which has been technically revised. The revision includes updates with respect to the state-of-the-art machine types, and exclusion of the soil stabilizers considered as agricultural machines; in addition, the scope has been limited to specialized machines used in road construction only.

Introduction

This International Standard deals with soil stabilizers used in road construction and pavement works.

It provides the terminology of the machine and its components, also the definitions of operation principles and parameters.

It deals with commercial specifications, and establishes parameters required for technical characteristics of a whole machine and its components, such as transport vehicle and mixing device.

www.iso.org

Road construction and maintenance equipment — Soil stabilizers — Terminology and commercial specifications

1 Scope

This International Standard establishes the terminology, definitions of operation and commercial specifications for soil stabilizers and their components intended for use in road construction and pavement works.

It does not apply to soil stabilizers used in agricultural applications.

2 Normative references

The following documents, in whole or in part, are normatively referenced in this document and are indispensable for its application. For dated references, only the edition cited applies. For undated references, the latest edition of the referenced document (including any amendments) applies..

ISO 3911, *Wheels and rims for pneumatic tyres — Vocabulary, designation and marking*

ISO 6746-1, *Earth-moving machinery — Definitions of dimensions and codes — Part 1: Base machine*

ISO 6746-2, *Earth-moving machinery — Definitions of dimensions and codes — Part 2: Equipment and attachments*

ISO 7134, *Earth-moving machinery — Graders — Terminology and commercial specifications*

3 Terms and definitions

For the purposes of this document, the following terms and definitions apply.

3.1

soil stabilizer

self-propelled machine, either towed or transported, with the function of pulverizing, breaking-up, aerating, homogenizing, and loosening existing and imported soil or paving materials and mixing them together with one or more additive materials such as filler, cement or lime

NOTE The main purpose of a soil stabilizer is to improve the mechanical and physical properties of the soil material by mixing it with binders (cement, lime, etc.) or filler.

3.2

transport machine

machine carrying all of the components, providing movement of the mixing device during work and between work areas

3.3

mixing device

device comprised of active components that work the materials in place, e.g. either by mixing or breaking up actions

NOTE The mixing device normally comprises a powered rotor equipped with tools, which rotates during the mixing operation (Figures A.1 to A.5). Another type of mixing device may utilize special tools that reciprocate during the mixing operation (Figure A.6).

**3.4
variable mixer chamber**

chamber, equipped with gates or flaps, which controls the time the materials remain in the mixing chamber

**3.5
fixed mixer chamber**

chamber without gates or flaps so no variation of mixing time is possible

4 Types and configuration of soil stabilizers

4.1 Types

Depending on the mixing device, there are two different types of soil stabilizer:

- a) mixing: using rotating tools to cut and reduce to aggregate the material in a mixing chamber (see Figures A.1 to A.5). The rotation axis of the rotors may be horizontal or vertical;
- b) breaking up: using special tools with reciprocating movement (digging machine, see Figure A.6).

4.2 Configuration

The configuration of soil stabilizers is determined by either the position of the mixing tools in relation to the axles of the transport machine or the type and layout of the working tools with which the machine is equipped.

- a) Position of mixing tool:
 - central: the mixing device is suspended between front and rear axles (see Figures A.1 and A.2);
 - rear: the mixing device is carried behind the axles (see Figures A.3 to A.6).
- b) Type and layout of working tool:
 - tools fixed to a horizontal axis rotary drum (see Figures A.1 to A.4 and Figures A. 7 to A.10);
 - tools fixed to the vertical axis rotary disc (see Figure A.5);
 - tools in form of digging device (see Figures A.6 and A.8).

4.3 Tool driving principle

The movement of tools is provided by mechanical or hydraulic driving systems.

5 Commercial specifications

5.1 General

The dimensional and mass characteristics specified below do not apply to grader-based soil stabilizers. For these machines, the specifications given in ISO 6746-1, ISO 6746-2 and ISO 7134 apply.

5.2 General data

Specify the following:

- a) Manufacturer or importer (if imported)
- b) Model

- | | |
|---------------------------------------|----|
| c) Power installed (specify standard) | kW |
| d) Shipping dimensions (overall) | |
| — Length | mm |
| — Width | mm |
| — Height: | |
| — without cab | mm |
| — with cab | mm |
| e) Shipping mass | kg |

5.3 Dimensional characteristics

5.3.1 Overall dimensions of a machine in operating mode

See Figure A.12.

The following dimensions shall be specified.

- | | |
|--------------------|----|
| — Length, L | mm |
| — Width, W | mm |
| — Height: | |
| — without cab, E | mm |
| — with cab, H | mm |

5.3.2 Ground clearance

Specify the ground clearance with tool raised (see Figure A.13).

5.3.3 Wheel base

See Figure A.12.

The following dimensions shall be specified:

- | | |
|---|----|
| — Distance between axles, D | mm |
| — Distance between rotor axis and front-wheel axis, F | mm |
| — Distance between rotor axis and rear-wheel axis | mm |

5.3.4 Turning radius

The following dimensions shall be specified:

- | | |
|--------------------------|----|
| — Turning radius inside | mm |
| — Turning radius outside | mm |

5.3.5 Overhangs and offsets

The following dimensions shall be specified:

ISO 15688:2012(E)

— Front overhang	mm
— Rear overhang	mm
— Right lateral offset	mm
— Left lateral offset	mm

5.3.6 Characteristic angles

The following dimensions shall be specified:

— Central articulation angle of articulated chassis	+ deg.
— Central oscillation angle of articulated chassis	+ deg.
— Oscillation angle of front axle	+ deg.
— Oscillation angle of rear axle	+ deg.
— Cross slope/angle of rotor chamber	+ deg.

5.4 Mass and load characteristics

5.4.1 Operating mass

Specify the mass of the basic machine under the following conditions:

- Ready to run;
- With or without cab (to be stated)
- Including standard equipment
- With a driver of mass 75 kg
- With fuel and additive tanks half full
- With cooling, lubrication and hydraulic systems full

5.4.2 Load per axle

The following shall be specified:

— Load measured on front axle	daN
— Load measured on rear axle	daN

5.4.3 Other masses

Specify the mass of ballast, in kilograms.

5.5 Engine characteristics

The following characteristics shall be specified:

— Manufacturer and model	
— Power (specify standard)	kW

- Cooling type
- Exhaust compliance (specify standard)

5.6 Characteristics and type of wheels/crawlers

- a) Soil stabilizers based on wheeled chassis:
- Front wheel dimensions (according to ISO 3911)
 - Rear wheel dimensions (according to ISO 3911)
 - Number of wheels:
 - front
 - rear
 - Number of driven wheels:
 - front
 - rear
- b) Soil stabilizers based on crawler:
- Number of crawlers
 - Number of idlers:
 - front
 - rear
 - Number of drive sprockets:
 - front
 - rear

5.7 Traction transmission characteristics

The following characteristics shall be specified:

- Transmission type:
 - hydrostatic
 - mechanical
 - hydro-mechanical
 - electrical

5.8 Working and travelling speeds

The following characteristics shall be specified:

- Number of speed ranges:
 - forward
 - backward
- Range of working speeds m/min
- Maximum travelling speed km/h

5.9 Steering characteristics

The following characteristics shall be specified:

- Wheel steering:
 - front-wheel drive
 - rear-wheel drive
 - front- and rear-wheel drive
 - coordinated steering
 - crab steering
- Articulated chassis:
 - front-wheel drive
 - rear-wheel drive
 - front- and rear-wheel drive
 - coordinated steering
 - crab steering

5.10 Characteristics of the mixing devices

5.10.1 Soil stabilizer with horizontal axis mixing device

5.10.1.1 Dimensions

The following dimensions shall be specified:

- Overall width of mixing chamber, W_c (see Figure A.12) mm
- Overall diameter of mixing chamber mm
- Cutting width of rotor mm
- Rotor diameter at end of tool mm

5.10.1.2 Type of tools

The following characteristics shall be specified:

- pick (see Figure A.7)
- spade (see Figure A.8)

- hammer (see Figure A.9)
- knife: curve, *L* (see Figure A.10)
- other

5.10.1.3 Positioning of tools on the rotor

Specify the following.

- helical pattern
- in line
- step mm

5.10.1.4 Tool attachment method

Specify the following:

- Wedged
- Bolted
- Tapered fit
- Spring sleeve

5.10.1.5 Tool holder

Specify the following:

- Tool holder type:
 - for single tool
 - for multiple tools
- Tool-holder attachment:
 - welded
 - bolted

5.10.1.6 Rotor-drive rotation direction and speed

Specify the following:

- Rotor-drive type:
 - mechanical
 - hydraulic
- Rotation direction:
 - reverse in relation to travelling direction
 - same as travelling direction
 - in both directions

ISO 15688:2012(E)

- Number of rotor drive speeds:
 - max./min. revolutions of rotor rev/min
 - max./min. peripheral speed at end of tool m/min

5.10.1.7 Rotor side shift

Specify the following:

- Total offset mm
- Left offset from neutral position mm
- Right offset from neutral position mm

5.10.1.8 Mixing depth

Specify the following:

- Maximum depth of mixing mm
- Limitation due to material density mm

5.10.1.9 Slope

Specify the following:

- Cutting capability degrees

5.10.2 Soil stabilizer with vertical axis

Specify the following:

- Overall width mm

5.10.2.1 Mixing depth

- Maximum depth of mixing mm

5.10.2.2 Rotors

Specify the following:

- Number of rotors
- Rotor diameter at end of teeth mm
- Number of rotor drive speeds
- Revolutions of rotor rev/min
- Drive mode:
 - mechanical
 - hydraulic

5.10.2.3 Blades

Specify the following:

- Number of blades per rotor
- Type of blades:
 - straight
 - tilted
 - articulated

5.10.2.4 Digging device

Specify the following:

- Working depth mm
- Working width mm
- Device mass kg
- Number of spades
- Spade attachment method
- Power required kW

5.11 Equipment

5.11.1 Additive system

5.11.1.1 General data for additive system

Specify the following:

- Additive delivery method:
 - by on-board pump
 - by independent pump
 - others (gravity, pressure, etc.)

5.11.1.2 Place where liquid is added

Specify whether

- Inside mixing chamber
- Outside mixing chamber

5.11.1.3 Flow regulation method

Specify whether

- Automatic control by machine movement speed with machine speed movement servo-control system (and whether this mode available for forward and reverse movements)

ISO 15688:2012(E)

- Automatic on/off control by machine movement speed
- Manual control by control valve or pump's speed

5.11.1.4 Description of parameters displayed

Specify the following:

- Max./min. flow l/min
- Max./min. pressure MPa
- Max./min. working temperature °C

5.11.1.5 Pump characteristics

Specify the following:

- Type
- Max./min. flow l/min
- Location
- Drive type

5.11.1.6 Additive supply method

Specify the following:

- Whether from machine's on-board tank
- Whether from tank independent of machine
- Tank capacity

5.11.1.7 Additive used

- Types of additive
- Max./min. working viscosity cSt
- Temperature range °C

5.11.1.8 Control of delivery when machine stops

Specify whether

- Manual
- Automatic

5.11.1.9 Functional characteristics of delivery

Specify the following:

- By ramp/width: mm

- range of setting of width or no variation mm
- variable width per sector (length of each sector) mm
- By jets (number):
 - distance between two jets mm
 - capacity of jets/nozzles l/min

5.11.2 System to measure working depth

Specify the following:

- Operating method (ultrasound, mechanical, etc.)
- Level reference (ground, machine element, laser, etc.)
- Depth reading:
 - inside cab
 - outside cab
- Depth recording
- Control type:
 - manual
 - automatic

5.11.3 Gates of mixing chamber

Specify the following:

- Location of gates in mixing chamber (front, rear, both)
- Type of gate:
 - rigid
 - flexible
- Gate adjustment method:
 - manual
 - mechanical
 - hydraulic
- Dimensional characteristics:
 - width in open position:
 - front and/or mm
 - rear mm
 - maximum height in open position in relation to ground (see Figure A.11) mm

5.11.4 Load control system for working tools

Specify the following:

- a) Whether load can be reduced by
 - infinitely variable reduction of travel speed
 - automatic control and modification of rotor rotation speed
 - raising working tool manually or automatically
- b) Whether the impact load protection of the rotor drive system is via
 - replaceable shear pin
 - torque limiting device
 - hydrostatic overload detection and protection system

5.11.5 Driving aid system

Specify the following:

- Type of system
- Information given on dashboard

Annex A
(informative)

Examples of soil stabilizer types, tools and dimensional characteristics

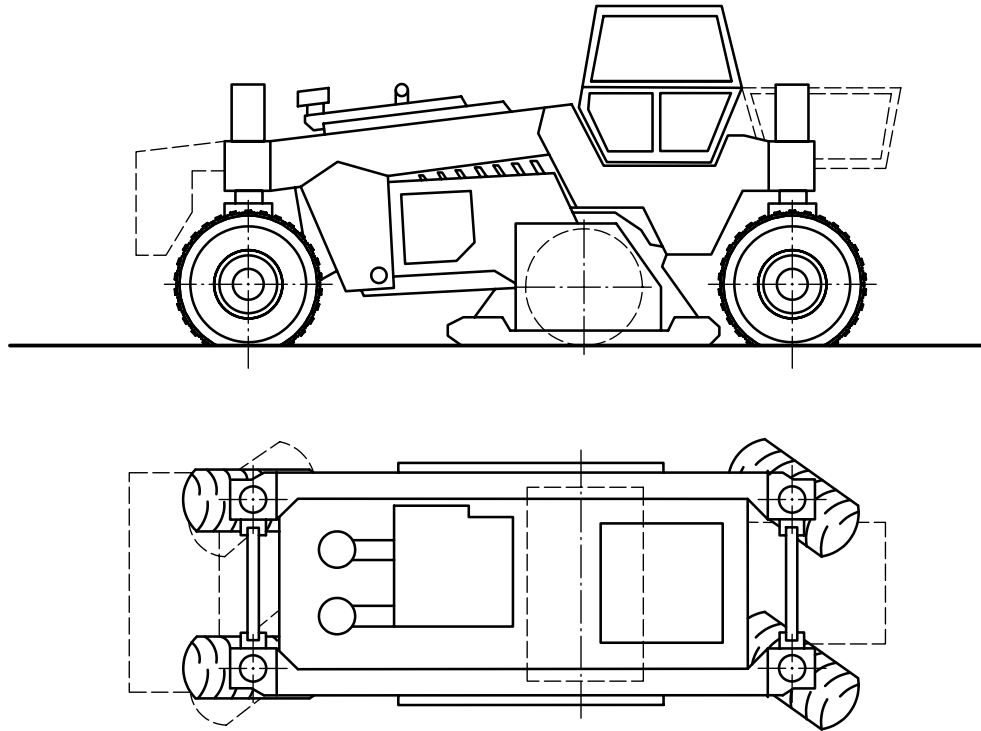

Figure A.1 — Central soil stabilizer with horizontal rotor

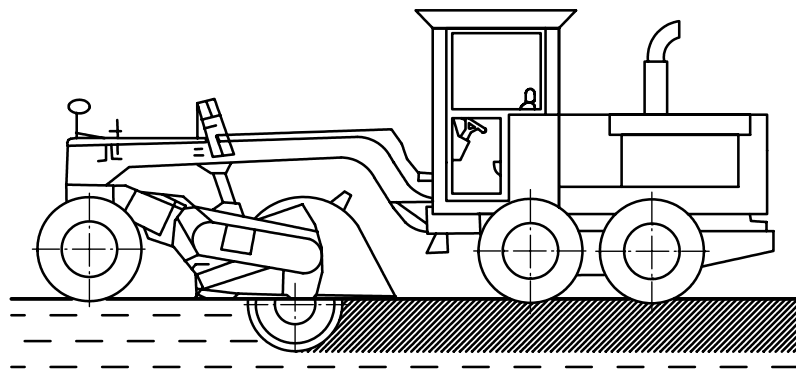

Figure A.2 — Grader-based central soil stabilizer with horizontal rotor

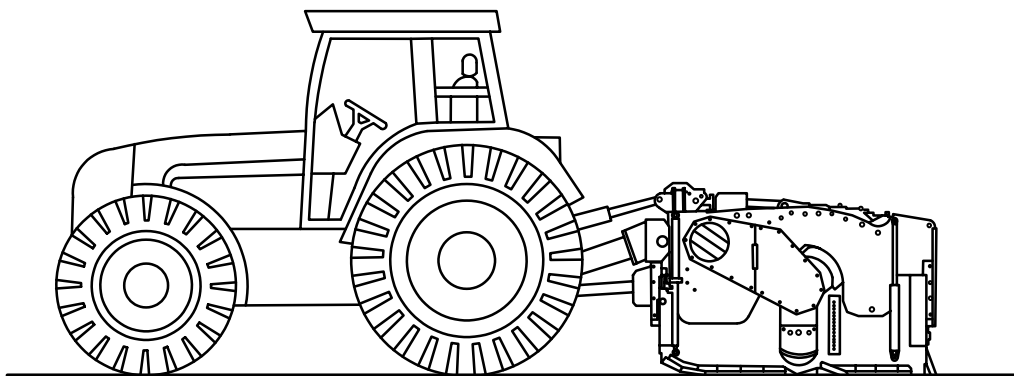

Figure A.3 — Rear soil stabilizer with horizontal rotor

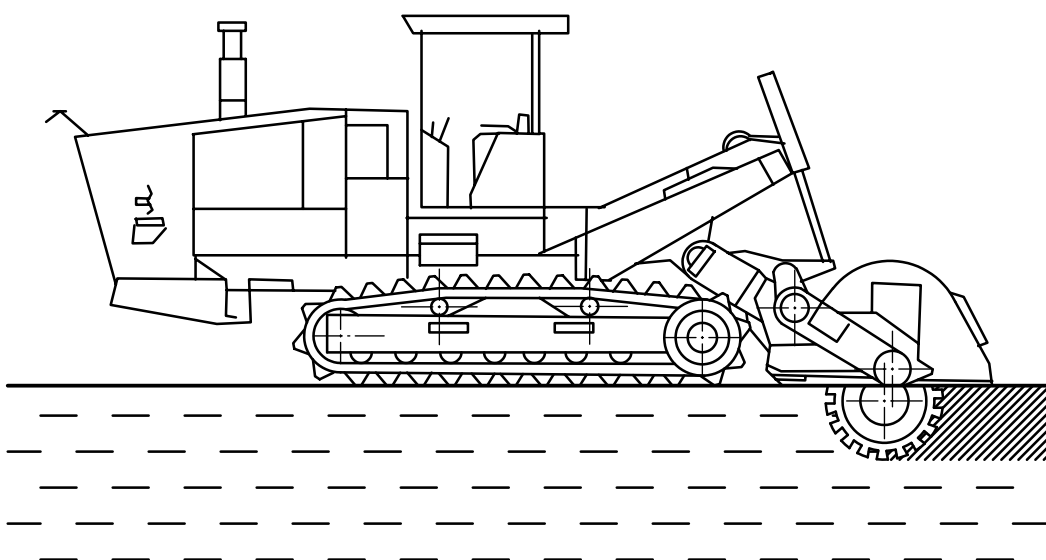

Figure A.4 — Crawler-based rear soil stabilizer with horizontal rotor

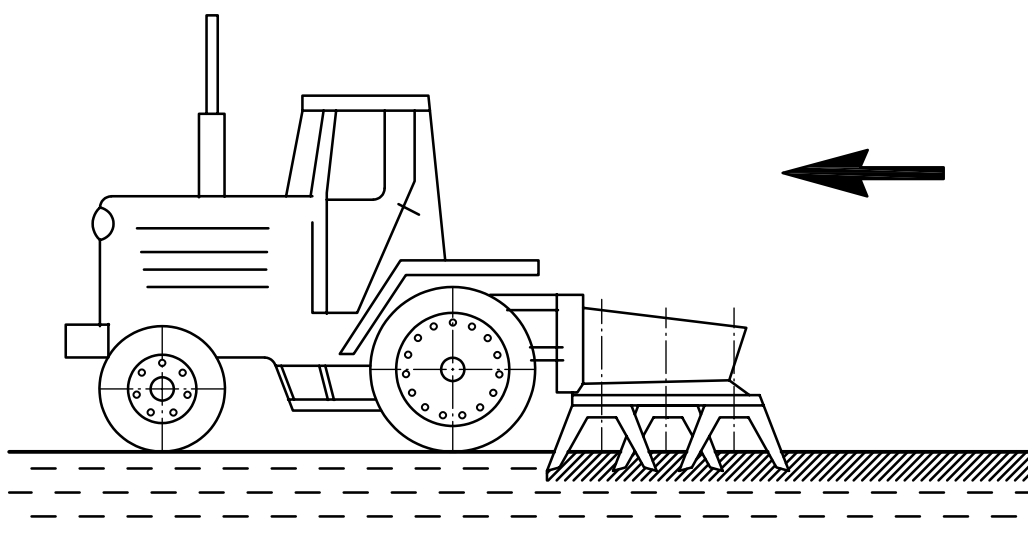

Figure A.5 — Rear soil stabilizer with vertical rotors

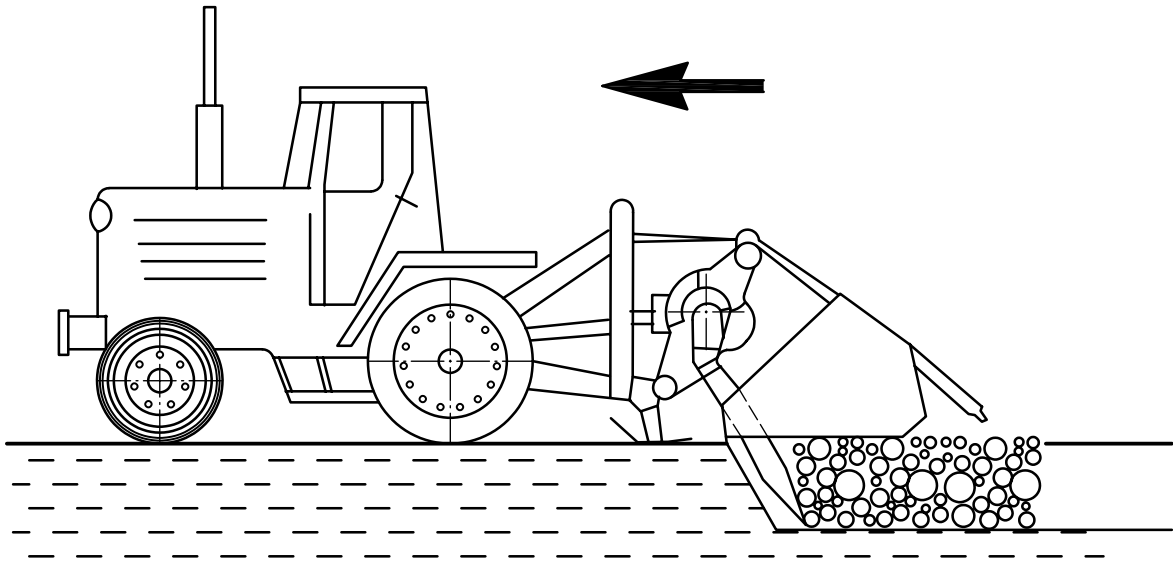

Figure A.6 — Rear digging mixer with horizontal axis

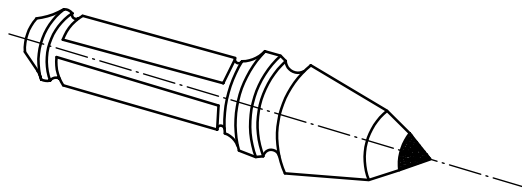

Figure A.7 — Pick-type tool

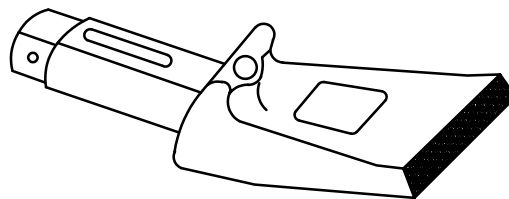

Figure A.8 — Spade-type tool

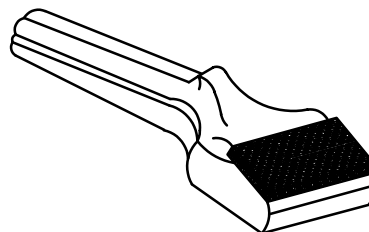

Figure A.9 — Hammer-type tool (clay spade)

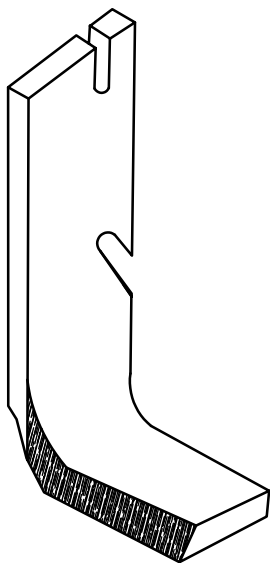
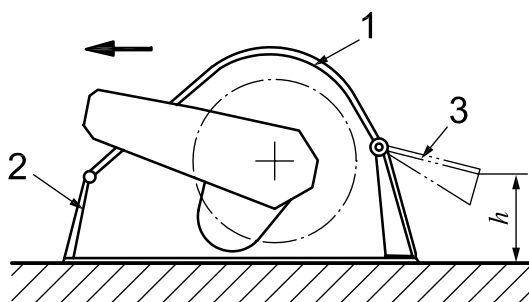

Figure A.10 — L-shaped knife tool



Key

- 1 housing of mixing chamber
- 2 front gate
- 3 rear gate

Figure A.11 — Opening height of gate in relation to ground

No reproduction or networking permitted without license from IHS

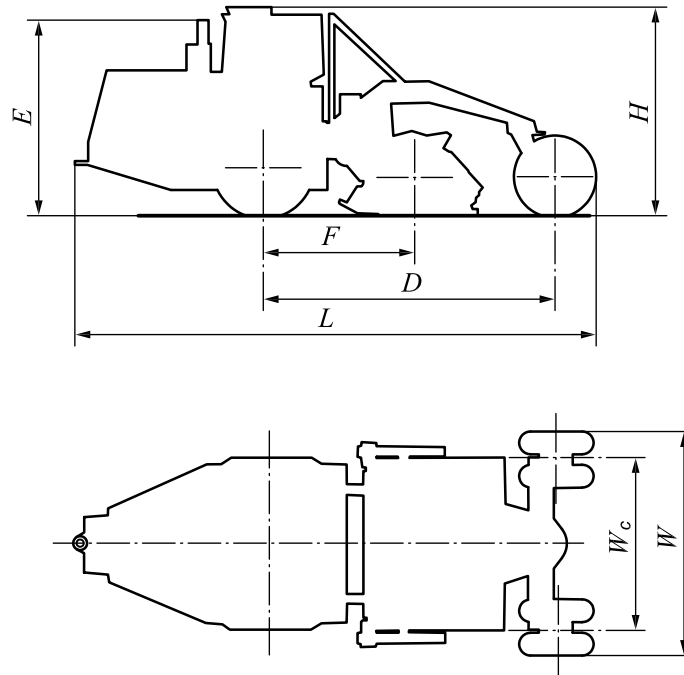

Key

- L overall length
- W overall width
- H overall height
- E height without cab
- D distance between axes
- F distance between rotor and front wheel axes
- W_c overall width of mixing chamber

Figure A.12 — Dimensional characteristics of soil stabilizer

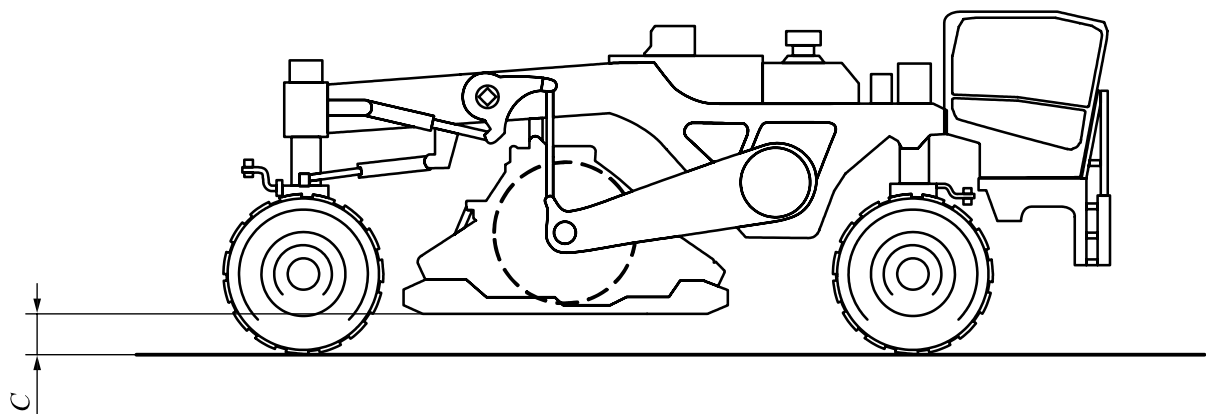

Key

- C ground clearance

Figure A.13 — Example of ground clearance dimensioning for soil stabilizer

Bibliography

- [1] NF P 98-712, *Road construction and maintenance equipment — Soil stabilization or retread process: Binder spreader plants and pulvi-mixers — Terminology*
- [2] EN 500-3:2006+A1:2009, *Mobile road construction machinery — Safety — Part 3: Specific requirements for soil stabilization machines*

