

INTERNATIONAL STANDARD

ISO 15643

First edition
2002-03-01

Road construction and maintenance equipment — Bituminous binder spreaders/sprayers — Terminology and commercial specifications

*Équipement pour la construction et l'entretien des routes —
Épandeuces/pulvérisatrices de liants bitumineux — Terminologie et
spécifications commerciales*



Reference number
ISO 15643:2002(E)

© ISO 2002

PDF disclaimer

This PDF file may contain embedded typefaces. In accordance with Adobe's licensing policy, this file may be printed or viewed but shall not be edited unless the typefaces which are embedded are licensed to and installed on the computer performing the editing. In downloading this file, parties accept therein the responsibility of not infringing Adobe's licensing policy. The ISO Central Secretariat accepts no liability in this area.

Adobe is a trademark of Adobe Systems Incorporated.

Details of the software products used to create this PDF file can be found in the General Info relative to the file; the PDF-creation parameters were optimized for printing. Every care has been taken to ensure that the file is suitable for use by ISO member bodies. In the unlikely event that a problem relating to it is found, please inform the Central Secretariat at the address given below.

© ISO 2002

All rights reserved. Unless otherwise specified, no part of this publication may be reproduced or utilized in any form or by any means, electronic or mechanical, including photocopying and microfilm, without permission in writing from either ISO at the address below or ISO's member body in the country of the requester.

ISO copyright office
Case postale 56 • CH-1211 Geneva 20
Tel. + 41 22 749 01 11
Fax + 41 22 749 09 47
E-mail copyright@iso.ch
Web www.iso.ch

Printed in Switzerland

Contents

Page

Foreword.....	iv
1 Scope	1
2 Terms and definitions	1
3 Description of spreader components.....	3
3.1 Transport vehicle.....	3
3.2 Tank.....	3
3.3 Binder transfer device.....	3
3.4 Spray bar	3
3.5 Control station	3
4 Commercial specifications	4
4.1 Spreader components list.....	4
4.2 Vehicle characteristics.....	4
4.3 Tank: performance and characteristics	5
4.4 Burner	7
4.5 Binder transfer unit: bitumen pumping and transmission characteristics	8
4.6 Spray bar: performance and characteristics	9
4.7 Control station performance	13
Bibliography.....	14

Foreword

ISO (the International Organization for Standardization) is a worldwide federation of national standards bodies (ISO member bodies). The work of preparing International Standards is normally carried out through ISO technical committees. Each member body interested in a subject for which a technical committee has been established has the right to be represented on that committee. International organizations, governmental and non-governmental, in liaison with ISO, also take part in the work. ISO collaborates closely with the International Electrotechnical Commission (IEC) on all matters of electrotechnical standardization.

International Standards are drafted in accordance with the rules given in the ISO/IEC Directives, Part 3.

The main task of technical committees is to prepare International Standards. Draft International Standards adopted by the technical committees are circulated to the member bodies for voting. Publication as an International Standard requires approval by at least 75 % of the member bodies casting a vote.

Attention is drawn to the possibility that some of the elements of this International Standard may be the subject of patent rights. ISO shall not be held responsible for identifying any or all such patent rights.

ISO 15643 was prepared by Technical Committee ISO/TC 195, *Building construction machinery and equipment*.

Road construction and maintenance equipment — Bituminous binder spreaders/sprayers — Terminology and commercial specifications

1 Scope

This International Standard establishes the terminology for soil stabilizers used in road construction and pavement works. It provides the terminology for the machine and its components, also the definitions of operation principles and parameters.

This International Standard also establishes the parameters required for the technical characteristics of the whole machine and its components, such as the transport vehicle and mixing device, for commercial specifications.

2 Terms and definitions

For the purposes of this International Standard, the following terms and definitions apply.

2.1

bituminous binder spreader

machine used to apply a film of binder on a pavement at a predetermined application rate

NOTE The particular spreader types may be defined by associating the operating principle, the shape of the components, the type of binder, and by specifying the spreading performances.

2.2

displacement pump spreader

machine in which binder transfer from the storage tank to the spray bar is provided by a pump

NOTE The pump's output is proportional to its rotating speed which may be controlled by the vehicle movement speed.

2.3

constant pressure spreader

machine in which binder transfer from the storage tank to the spray bar is provided by pressurizing the binder

NOTE The binder may be pressurized directly by compressed air above the binder, or by a pump and regulating valve maintaining a constant binder pressure in the spray bar feeder circuit.

2.4

fixed assembly spreader

machine in which the tank and its attachments are fixed to the transport vehicle

2.5

removable assembly spreader

machine in which the tank and its attachments are fixed to a removable chassis

2.6

heat-insulated spreader

machine in which the tank is equipped with thermal insulation to avoid heat loss

2.7

directly heated spreader

machine with heating provided by circulation of hot gases in a tube or by an electrical resistor in contact with the binder

2.8

indirectly heated spreader

machine with heating provided by circulation of a hot liquid supplied by a generator outside or inside the spreader

2.9

hot binder spreader

machine which enables application of binder at a temperature greater than 80 °C

2.10

cold binder spreader

machine which spreads binders at a temperature lower than 80 °C

2.11

high-viscosity-binder spreader

machine which enables application of a binder with a viscosity greater than 300 cSt at the application temperature

2.12

high-binder-pressure spreader

machine in which the binder pressure in the spray bar during spreading is greater than 0,2 MPa

2.13

medium-binder-pressure spreader

machine in which the binder pressure in the spray bar during spreading is between 0,02 MPa and 0,2 MPa

2.14

low-binder-pressure spreader

machine in which the binder pressure in the spray bar during spreading is less than 0,02 MPa

2.15

tank volume

internal volume of the tank

NOTE It is expressed in cubic metres.

2.16

rated capacity

volume of binder which can be carried

NOTE It is expressed in cubic metres.

2.17

nominal loading of tank

loading using the available capacity of the binder with the highest density

NOTE It is expressed in kilograms.

2.18

spray bar width

distance between end flow points

NOTE It is expressed in metres.

2.19**maximum output of pumping unit**

largest capacity for a binder with a viscosity of 100 cSt

NOTE It is expressed in cubic metres per hour.

2.20**nominal application rate**

application rate at maximum output of a pumping unit moving at a speed of 4 km/h with a binder of a density of 1 g/cm³ and a viscosity of 100 cSt and with maximum spray bar width

NOTE It is expressed in kilograms per square metre.

2.21**binder carrying capacity**

difference between the laden and kerb mass of a spreader

2.22**spreading height**

height measured between the average plane of the pavement and the orifice of the nozzles

NOTE 1 It is expressed in metres.

NOTE 2 See h_2 in Figure 7.

3 Description of spreader components**3.1 Transport vehicle**

This vehicle, in the form of a truck, trailer or semi-trailer, carries all the components and provides movement of the spreader during spreading and during road transfers.

3.2 Tank

The tank is used to store the binder during work and transport.

It may have a facility to heat the binder and may have a system to protect against loss of heat.

3.3 Binder transfer device

This device provides transfer of the binder from the tank to the spray bar in order to apply a specific quantity to the pavement.

3.4 Spray bar

The spray bar distributes the binder uniformly across the pavement.

3.5 Control station

The control station contains all the control, adjustment, measuring and automatic control equipment. There are two types, as follows.

- a) Manual control: the operator adjusts all the operating parameters to obtain the required application rate.
- b) Automatic control: using predetermined operating parameters, automation ensures accuracy of the application rate.

4 Commercial specifications

4.1 Spreader components list

The components of the binder spreader/sprayer and their dimensions shall be specified. An example is shown in Figure 1.

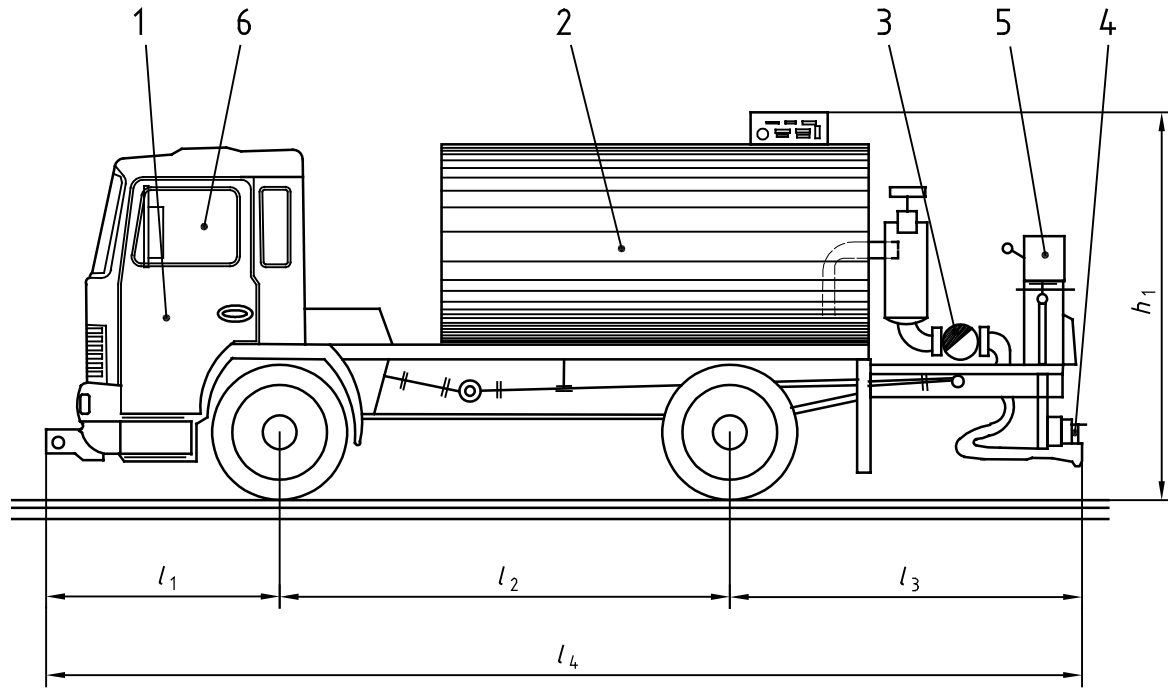

- Key**
- | | | | |
|---|----------------------|---------|--|
| 1 | Vehicle | 4 | Spray bar |
| 2 | Tank | 5 and 6 | Measuring instruments placed in driver's cab or on the rear part of the vehicle platform |
| 3 | Binder transfer unit | | |

Figure 1 — Overall view of binder spreader/sprayer

4.2 Vehicle characteristics

The following characteristics shall be specified:

- laden mass kg
- kerb mass kg
- binder carrying capacity kg
- minimum spreading speed km/h
- overall dimensions:
 - length, l_4 mm
 - width mm
 - height, h_1 mm

— front overhang, l_1	mm
— wheel base, l_2	mm
— rear overhang, l_3	mm
— external turning radius	m
— internal turning radius	m
— maximum axle load	daN
— engine rating power	kW
— maximum travel speed	km/h

4.3 Tank: performance and characteristics

4.3.1 General characteristics

The following characteristics shall be specified:

— tank volume	m^3
— rated capacity	m^3
— working pressure	MPa

4.3.2 Binder tank performance

The following units of the binder tank shall be specified (see Figures 2 and 3):

- tank itself, of the following geometrical shapes:
 - circular (see 1 in Figure 2),
 - elliptical (see 2 in Figure 2),
 - prismatic with rounded corners (see 3 in Figure 2);
- wash plate partition (see 4 in Figure 2);
- inspection hole (see 5 in Figure 2);
- cleaning orifice (see 6 in Figure 2);
- level indicator (see 7 in Figure 2);
- insulation: type and thickness (see 8 in Figure 2);
- insulation protective coating (see 9 in Figure 2);
- access equipment:
 - platform (see 10 in Figure 2),
 - access ladder to inspection hole (see 11 in Figure 2),
 - guard rail (see 12 in Figure 2);

ISO 15643:2002(E)

- heating device (see 13 in Figure 2);
- direct heating:
 - by open flame (see 1 in Figure 3),
 - by electricity (see 2 in Figure 3);
- indirect heating by thermal oil (see 3 in Figure 3).

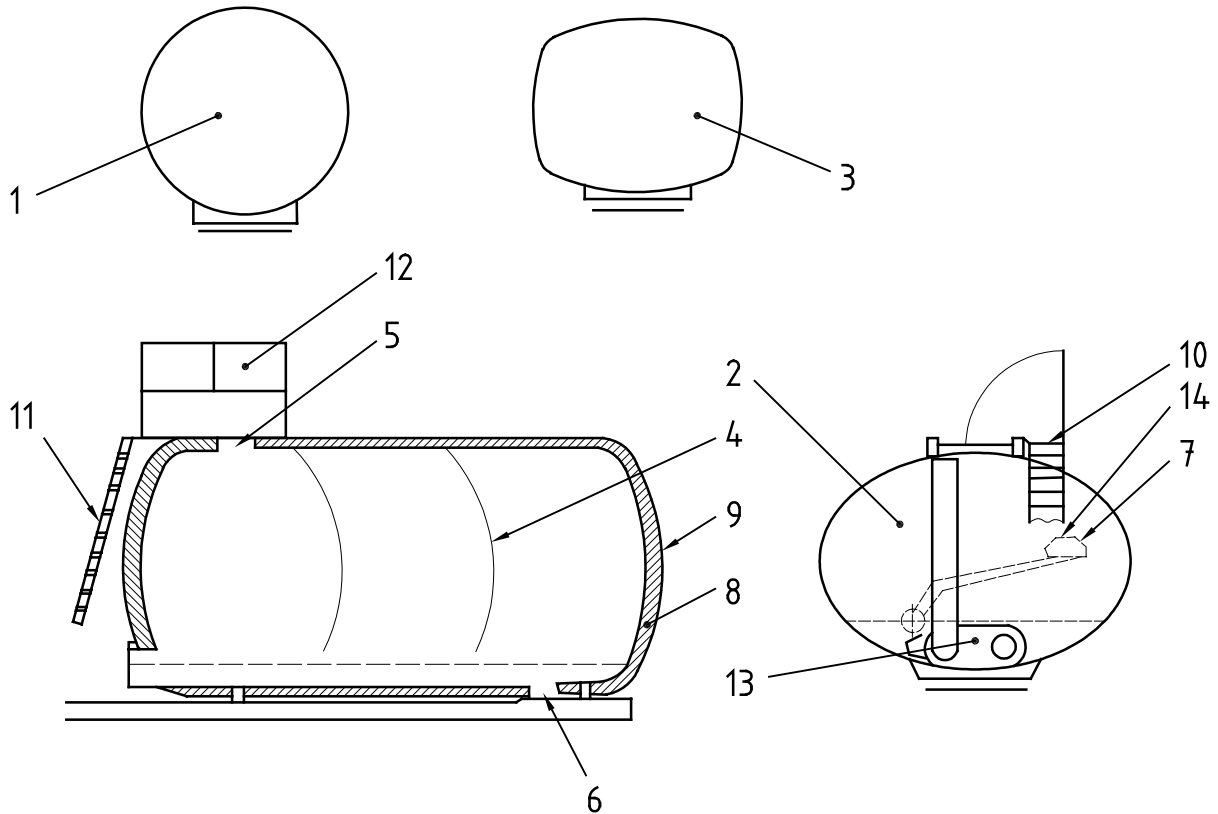

Key

- | | | | |
|---|-----------------------------------|----|--|
| 1 | Circular tank | 8 | Thickness of thermal insulation |
| 2 | Elliptical tank | 9 | Thermal insulation |
| 3 | Prismatic tank with round corners | 10 | Access platform |
| 4 | Wash plate partition | 11 | Ladder for access to inspection hole |
| 5 | Inspection hole | 12 | Guard rail |
| 6 | Cleaning orifice | 13 | Heating device |
| 7 | Level indicator | 14 | Detector for minimum/maximum level of binder |

Figure 2 — Bituminous binder tank performance

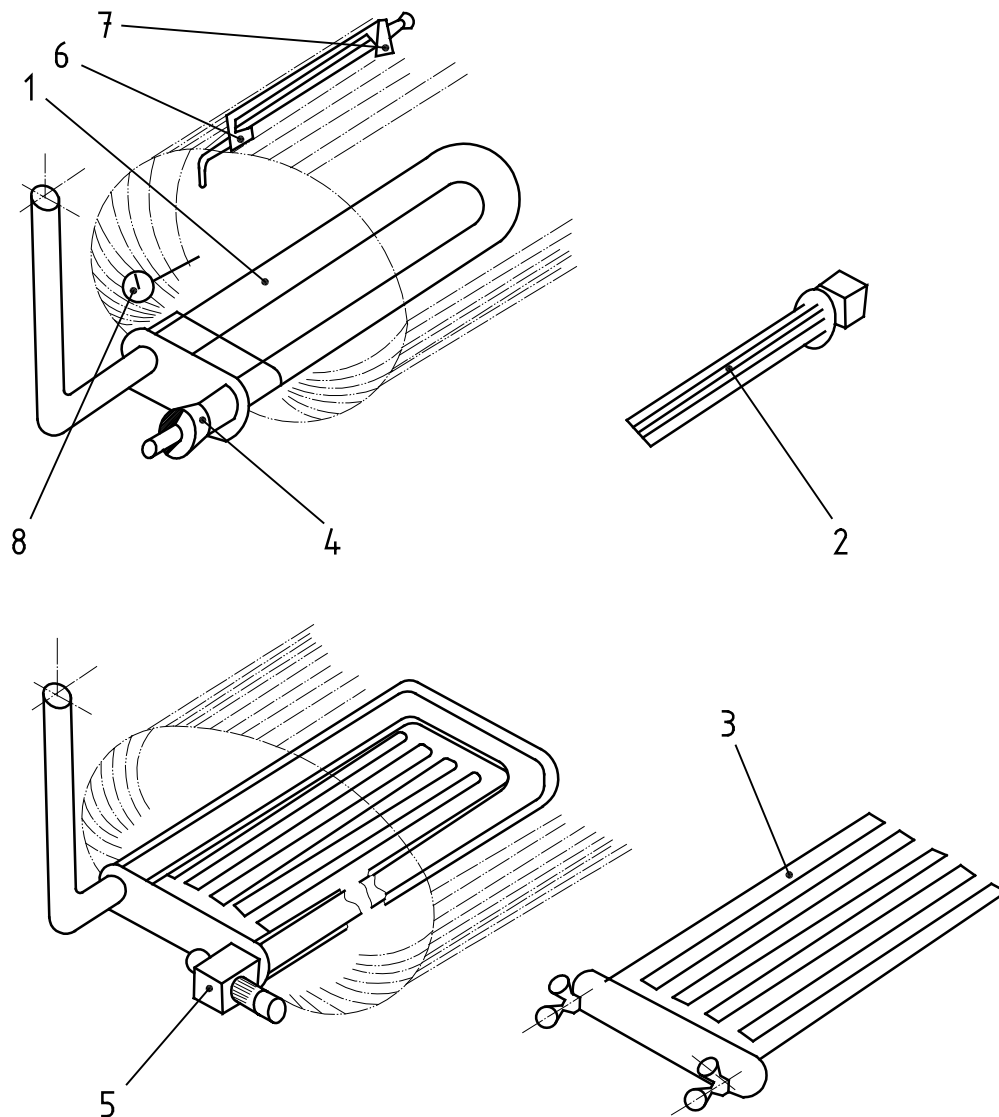

Key

- | | |
|---|--|
| 1 Direct heating by open flame | 5 Hot oil installation with automatic burner control |
| 2 Direct electric heating | 6 Venting device |
| 3 Indirect heating installation by hot oil | 7 Pressure and vacuum relief valve |
| 4 Hot oil installation with manual burner control | 8 Thermostat |

Figure 3 — Heating installation of bituminous binder tank

4.4 Burner

The following characteristics shall be specified:

- manual burner control (see 4 in Figure 3);
- automatic burner control (see 5 in Figure 3);
- detector for minimum binder level (see 14 in Figure 2);
- detector for maximum binder level (see 14 in Figure 2);
- venting device (see 6 in Figure 3);

- pressure and vacuum relief valve (see 7 in Figure 3);
- thermometer;
- thermostat (see 8 in Figure 3).

4.5 Binder transfer unit: bitumen pumping and transmission characteristics

The following characteristics shall be specified:

- displacement pump (see 1 in Figure 4):
 - rotation speed min^{-1} ,
 - output dm^3/min ;
- pump heating;
- filter (see 2 in Figure 4);
- transmission:
 - mechanical (see 3 in Figure 4),
 - hydrostatic (alternatively);
- power take-off on engine (see 4 in Figure 4);
- power take-off on gearbox (see 5 in Figure 4);
- auxiliary engine (see 2 in Figure 5);
- compressor (see 3 in Figure 5).

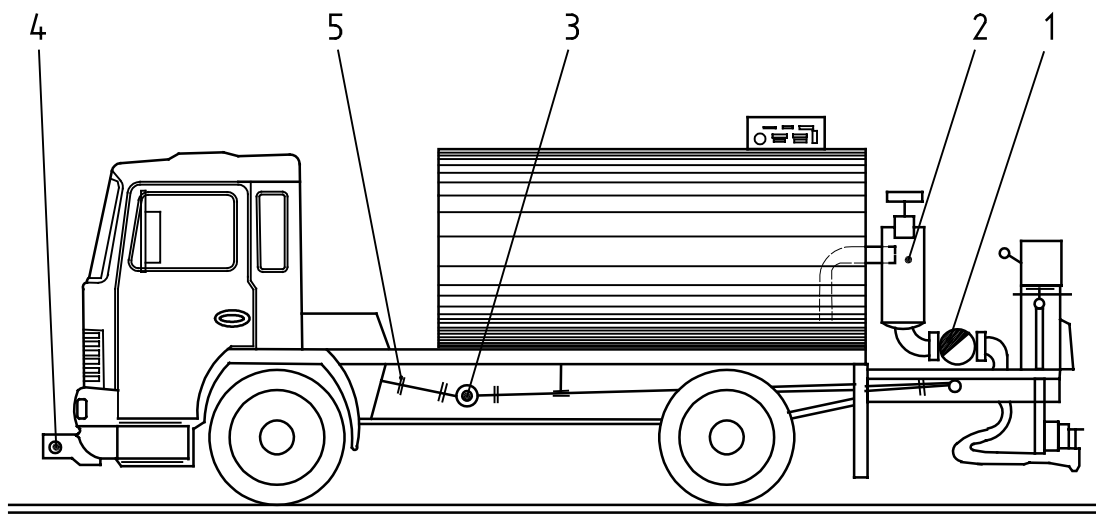

Key

- 1 Bitumen displacement pump
- 2 Bitumen filter
- 3 Bitumen pump drive
- 4 Power take-off on engine
- 5 Power take-off on gearbox

Figure 4 — Spreader with displacement pump for bitumen pumping

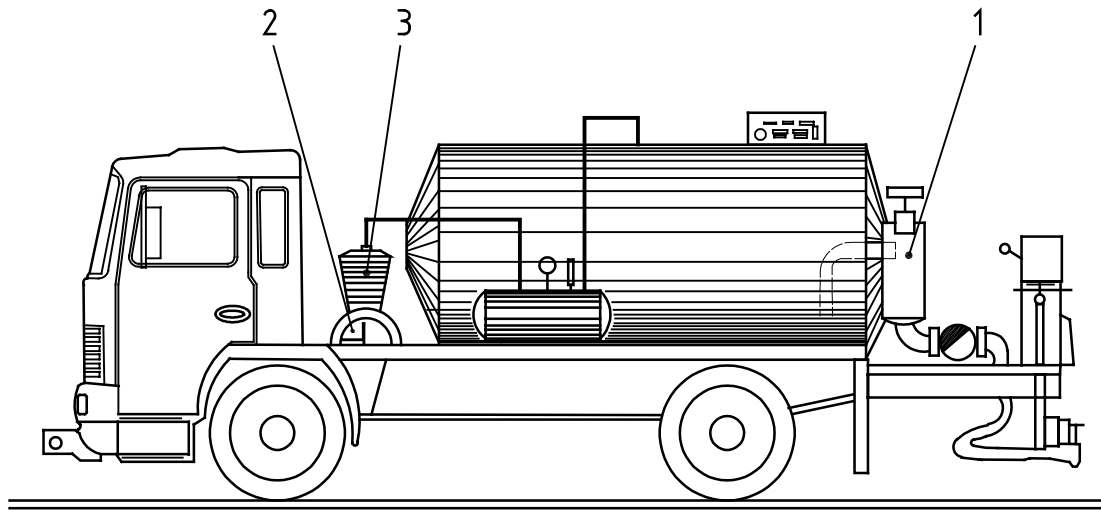

Key

- 1 Bitumen filter
- 2 Auxiliary engine for driving compressor
- 3 Air compressor

Figure 5 — Constant pressure spreader with air compressor for bitumen feeding

4.6 Spray bar: performance and characteristics

The following characteristics shall be specified:

- bar raising method:
 - mechanical,
 - pneumatic,
 - hydraulic;
- spreading height (see Figure 7), h_2 mm;
- height of spray bar in transport mm;
- minimum width of bar in transport position, b_1 mm;
- maximum width of bar in working position, b_2 mm;
- bar width (see Figure 7), b_3 mm;
- automatic correction of spray bar height during spreading, or without correction;
- pressure in the bar during operation Mpa;
- bar heated by:
 - circulation of binder,
 - hot oil,
 - electric resistor;

- spreading width:
 - full portion width (see Figure 7), b_4 mm,
 - medium width (see Figure 7), b_5 mm,
 - covered width (see Figure 7), b_6 mm;
- nozzles (see 4 in Figure 7):
 - number of nozzles,
 - nozzles control,
 - individual diffuser (see 5 in Figure 7),
 - collective diffuser for two nozzles or more,
 - mechanical,
 - pneumatic,
 - hydraulic,
 - spacing of nozzles (Figure 7), b_7 mm,
 - binder jet shape: coniform or flat (see 3 in Figure 7),
 - end flow correcting nozzle (see 4 in Figure 7);
- position of nozzles:
 - embedded in the spray bar,
 - outside the spray bar;
- orientation of nozzles (Figure 7), α 1°.

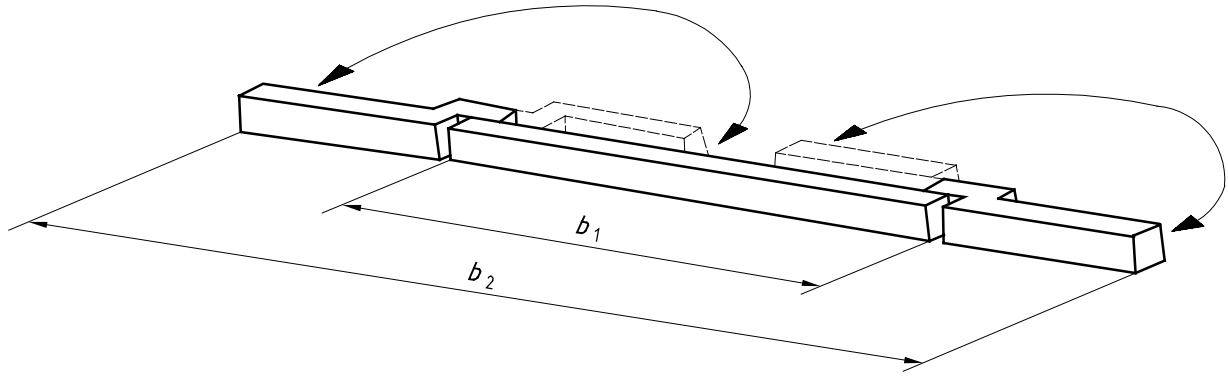

a) Spray bar with central unit and two folding extensions

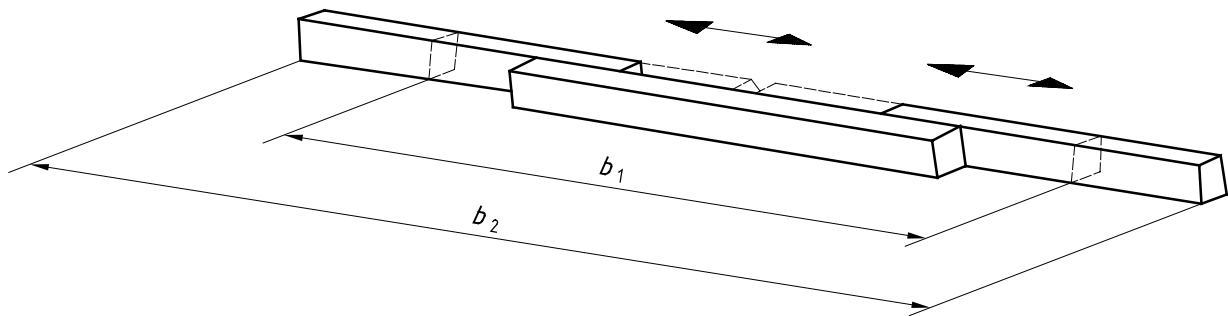

b) Spray bar with central unit and two pull-out extensions

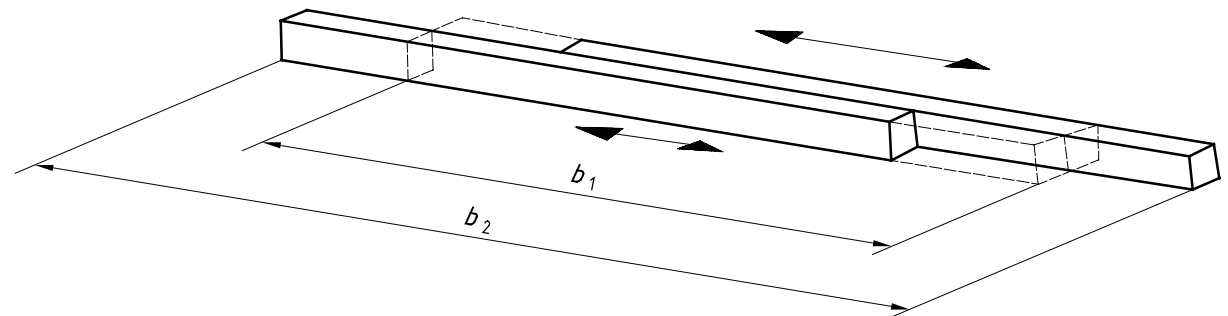

c) Bar in two pull-out extensions

b_1 Minimum width of bar in transport position

b_2 Maximum width of bar in working position

Figure 6 — Different designs of spray bar set-up

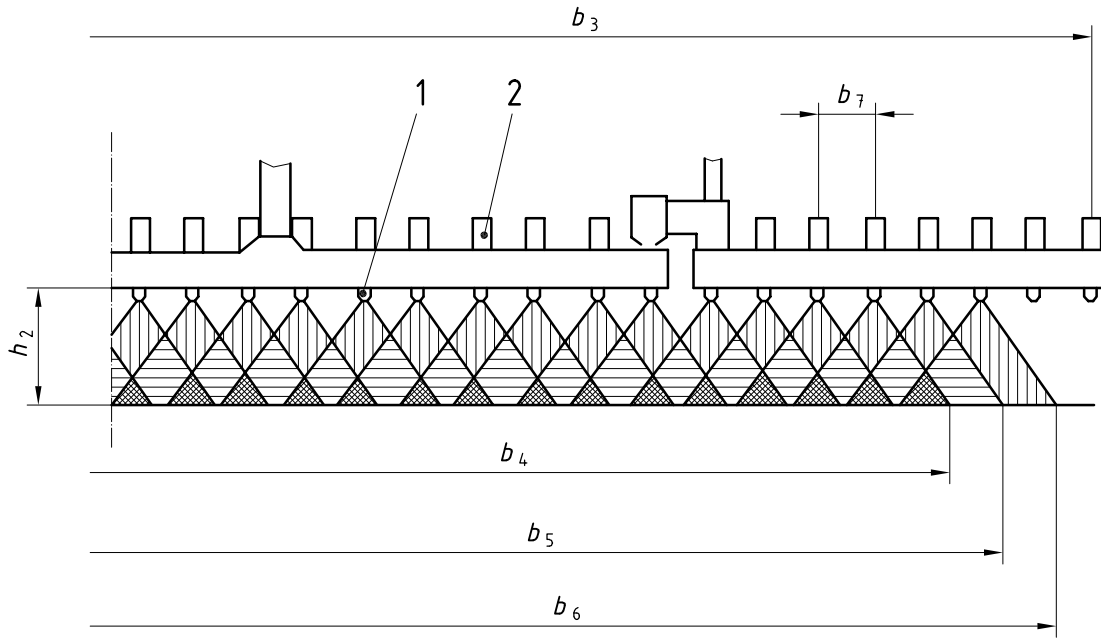

a) Spray bar composed of central unit and two extensions

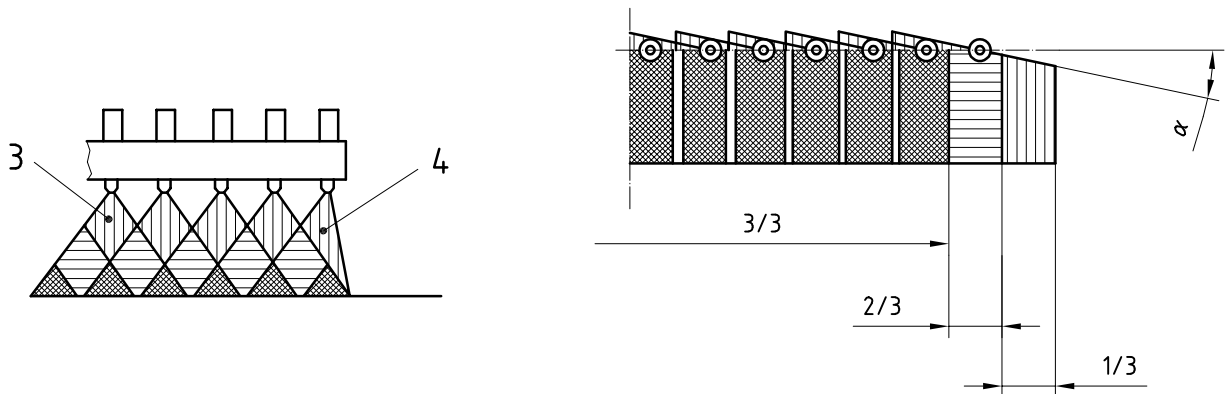

b) Extension bar with correcting nozzle

c) Spray bar with the width of the pavement covered with three (3/3), two (2/3) and one (1/3) nozzle(s)

- b_3 Bar width
- b_4 Full portion spreading width
- b_5 Medium spreading width
- b_6 Covered spreading width
- b_7 Spacing of nozzles
- h_2 Spreading height
- α Angle of nozzle placing in top view

Key

- 1 Nozzle
- 2 Individual nozzle
- 3 Flat binder jet shape
- 4 End flow correcting nozzle

Figure 7 — Spacing of nozzles and binder jet shape

4.7 Control station performance

4.7.1 Positioning, control and adjustment equipment

The type of equipment shall be specified for adjustment of:

- spray bar height;
- opening of nozzles:
 - general control,
 - individual control;
- transverse movement of the spray bar;
- spreading width.

4.7.2 Measuring and automatic control equipment

The following equipment shall be specified:

- pump speed indicator;
- truck speed indicator;
- spray bar pressure gauge;
- binder thermometer in tank;
- automatic correction device for spray bar height;
- automatic proportioning control and adjustment box;
- control to move the vehicle forward at regular speed;
- means of displaying, printing and storing parameters during adjustment and spreading;
- remote control box.

Bibliography

- [1] EN 536:1999, *Road construction machines — Asphalt mixing plants — Safety requirements*

ICS 91.220

Price based on 14 pages

© ISO 2002 – All rights reserved