Back-up pads for vulcanized fibre discs

Plateaux d'appui pour disques en fibres vulcanisées



PDF disclaimer

This PDF file may contain embedded typefaces. In accordance with Adobe's licensing policy, this file may be printed or viewed but shall not be edited unless the typefaces which are embedded are licensed to and installed on the computer performing the editing. In downloading this file, parties accept therein the responsibility of not infringing Adobe's licensing policy. The ISO Central Secretariat accepts no liability in this area.

Adobe is a trademark of Adobe Systems Incorporated.

Details of the software products used to create this PDF file can be found in the General Info relative to the file; the PDF-creation parameters were optimized for printing. Every care has been taken to ensure that the file is suitable for use by ISO member bodies. In the unlikely event that a problem relating to it is found, please inform the Central Secretariat at the address given below.

© ISO 2003

All rights reserved. Unless otherwise specified, no part of this publication may be reproduced or utilized in any form or by any means, electronic or mechanical, including photocopying and microfilm, without permission in writing from either ISO at the address below or ISO's member body in the country of the requester.

ISO copyright office
Case postale 56 • CH-1211 Geneva 20
Tel. + 41 22 749 01 11
Fax + 41 22 749 09 47
E-mail copyright@iso.org
Web www.iso.org

Published in Switzerland

Foreword

ISO (the International Organization for Standardization) is a worldwide federation of national standards bodies (ISO member bodies). The work of preparing International Standards is normally carried out through ISO technical committees. Each member body interested in a subject for which a technical committee has been established has the right to be represented on that committee. International organizations, governmental and non-governmental, in liaison with ISO, also take part in the work. ISO collaborates closely with the International Electrotechnical Commission (IEC) on all matters of electrotechnical standardization.

International Standards are drafted in accordance with the rules given in the ISO/IEC Directives, Part 2.

The main task of technical committees is to prepare International Standards. Draft International Standards adopted by the technical committees are circulated to the member bodies for voting. Publication as an International Standard requires approval by at least 75 % of the member bodies casting a vote.

Attention is drawn to the possibility that some of the elements of this document may be the subject of patent rights. ISO shall not be held responsible for identifying any or all such patent rights.

ISO 15636 was prepared by Technical Committee ISO/TC 29, *Small tools*, Subcommittee SC 5, *Grinding wheels and abrasives*.

.....

Back-up pads for vulcanized fibre discs

1 Scope

This International Standard specifies the design and dimensions of back-up pads intended for the fixing or clamping of vulcanized fibre discs in accordance with ISO 16057, or comparable grinding tools on hand-held grinding machines, e.g. angle grinders.

The connecting dimensions of support discs and clamping units are matched for spindle ends with the common practice of this kind of hand-held machine.

2 Normative references

The following referenced documents are indispensable for the application of this document. For dated references, only the edition cited applies. For undated references, the latest edition of the referenced document (including any amendments) applies.

ISO 16057, *Coated abrasives — Vulcanized fibre discs*

3 Design and dimensions

3.1 Design

See Figures 1 and 2.

Dimensions in millimetres

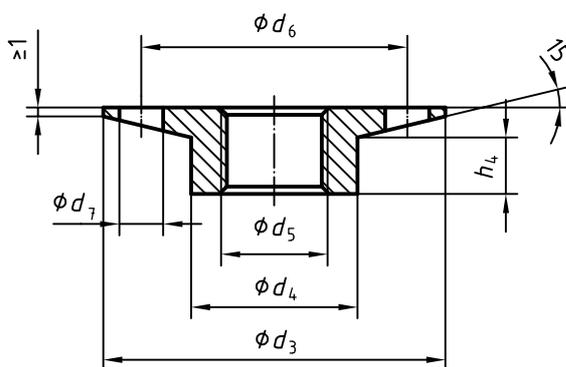

Figure 1 — Clamping nut

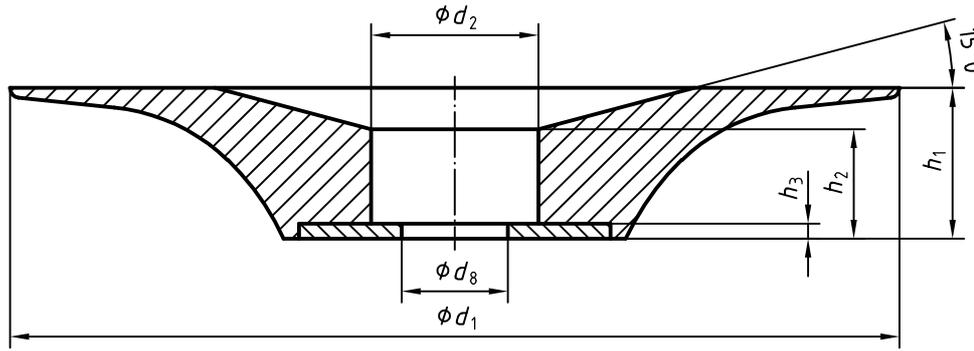

Figure 2 — Back-up pad

3.2 Dimensions

See Table 1.

Table 1 — Dimensions of back-up pads and nuts

Dimensions in millimetres

Vulcanized fibre discs ^a		Back-up pads						Nuts										
		d_1	d_2	d_8	h_1	h_2	h_3	d_3	d_4	Thread (d_5)	d_6	d_7	h_4					
D		± 1	$+0,5$ 0	H11	$\pm 0,4$	$\pm 0,4$	min.	$\pm 0,2$	0 $-0,3$		$\pm 0,1$	H12						
100	$\pm 1,5$	92,5	16	10	16	14,5	1,5	40	16	M10	20	4,5	$h_4 < h_2 - h_3$					
			22	14	20			45	22	M14	35	5,8						
115	$\pm 1,5$	107,5	22	14	20	14,5	2	45	22	M14	35	5,8						
				5/8"							5/8 UNC							
125	± 2	117	22	14	20	14,5	2,5	55	22	M14	35	5,8						
			5/8"													5/8 UNC		
150		142	22	14		12										M14		
			5/8"													5/8 UNC		
180		172	22	14		14,5				M14								
			40	14				40		5/8 UNC								
235		227	22	14		12			22	M14								
				5/8"						5/8 UNC								

^a In accordance with ISO 16057.

4 Requirements

4.1 Material

4.1.1 Back-up pad

The back-up pad shall be of polymer, the type of which shall be determined at the manufacturer's discretion.

4.1.2 Clamping nut

The clamping nut material shall be established at the manufacturer's discretion.

4.2 Scope of delivery

The scope of delivery comprises back-up pads and appropriated clamping nut.

5 Designation

A back-up pad conforming to this International Standard shall be designated by

- a) "Back-up pad";
- b) reference to this International Standard, i.e. ISO 15636;
- c) the outside diameter of the disc, d_1 , in millimetres;
- d) screw thread (the thread diameter of the nut d_5);
- e) maximum permissible frequency of rotation, minute to the power minus one (min^{-1}).

EXAMPLE A back-up pad with a diameter, $d_1 = 107,5$ mm, diameter, $d_5 = 5/8$ UNC and a maximum permissible frequency of rotation of $13\,300 \text{ min}^{-1}$ is designated as follows:

Back-up pad ISO 15636 — 107,5 × 5/8 UNC/13300

6 Marking

A back-up pad in accordance with this International Standard shall be marked with:

— manufacturer or supplier or importer or their registered trademark,

and

— maximum permissible speed of rotation.

ICS 25.100.70

Price based on 3 pages

<https://www.iso.org/standard/44122.html>