**Steel for the reinforcement and
prestressing of concrete — Test
methods —**

**Part 1:
Reinforcing bars, wire rod and wire**

*Aciers pour l'armature et la précontrainte du béton — Méthodes
d'essai —*

Partie 1: Barres, fils machine et fils pour béton armé



PDF disclaimer

This PDF file may contain embedded typefaces. In accordance with Adobe's licensing policy, this file may be printed or viewed but shall not be edited unless the typefaces which are embedded are licensed to and installed on the computer performing the editing. In downloading this file, parties accept therein the responsibility of not infringing Adobe's licensing policy. The ISO Central Secretariat accepts no liability in this area.

Adobe is a trademark of Adobe Systems Incorporated.

Details of the software products used to create this PDF file can be found in the General Info relative to the file; the PDF-creation parameters were optimized for printing. Every care has been taken to ensure that the file is suitable for use by ISO member bodies. In the unlikely event that a problem relating to it is found, please inform the Central Secretariat at the address given below.



COPYRIGHT PROTECTED DOCUMENT

© ISO 2010

All rights reserved. Unless otherwise specified, no part of this publication may be reproduced or utilized in any form or by any means, electronic or mechanical, including photocopying and microfilm, without permission in writing from either ISO at the address below or ISO's member body in the country of the requester.

ISO copyright office
Case postale 56 • CH-1211 Geneva 20
Tel. + 41 22 749 01 11
Fax + 41 22 749 09 47
E-mail copyright@iso.org
Web www.iso.org

Published in Switzerland

Contents

Page

| | |
|--|----|
| Foreword | v |
| Introduction..... | vi |
| 1 Scope | 1 |
| 2 Normative references | 1 |
| 3 Symbols..... | 1 |
| 4 General provisions concerning test pieces..... | 3 |
| 5 Tensile test..... | 3 |
| 5.1 Test piece | 3 |
| 5.2 Test equipment..... | 3 |
| 5.3 Test procedure..... | 4 |
| 6 Bend test | 5 |
| 6.1 Test piece | 5 |
| 6.2 Test equipment..... | 5 |
| 6.3 Test procedure..... | 5 |
| 6.4 Interpretation of test results..... | 6 |
| 7 Rebend test | 6 |
| 7.1 Test piece | 6 |
| 7.2 Test equipment..... | 6 |
| 7.2.1 Bending device | 6 |
| 7.2.2 Rebending device..... | 6 |
| 7.3 Test procedure..... | 6 |
| 7.3.1 General | 6 |
| 7.3.2 Bending | 7 |
| 7.3.3 Artificial ageing..... | 7 |
| 7.3.4 Rebending | 7 |
| 7.4 Interpretation of test results..... | 7 |
| 8 Axial force fatigue test | 8 |
| 8.1 Principle of test..... | 8 |
| 8.2 Test piece | 8 |
| 8.3 Test equipment..... | 8 |
| 8.4 Test procedure..... | 9 |
| 8.4.1 Provisions concerning the test piece..... | 9 |
| 8.4.2 Upper force (F_{up}) and force range (F_r)..... | 9 |
| 8.4.3 Stability of force and frequency..... | 9 |
| 8.4.4 Counting of force cycles..... | 9 |
| 8.4.5 Frequency..... | 9 |
| 8.4.6 Temperature | 9 |
| 8.4.7 Validity of the test..... | 9 |
| 9 Chemical analysis | 9 |
| 10 Measurement of the geometrical characteristics..... | 10 |
| 10.1 Test piece | 10 |
| 10.2 Test equipment..... | 10 |
| 10.3 Test procedure..... | 10 |
| 10.3.1 Heights of transverse ribs or depths of indentations..... | 10 |
| 10.3.2 Height of longitudinal ribs (a') | 10 |
| 10.3.3 Transverse rib or indentation spacing (c) | 10 |
| 10.3.4 Pitch (P) | 11 |

| | | |
|--------|---|----|
| 10.3.5 | Part of the circumference without ribs or indentations (Σe_i)..... | 11 |
| 10.3.6 | Transverse rib or indentation angle (β) | 11 |
| 10.3.7 | Transverse rib flank inclination (α)..... | 11 |
| 10.3.8 | Width of transverse rib or width of indentation (b) | 13 |
| 11 | Determination of the relative rib or indentation area (f_R or f_P)..... | 13 |
| 11.1 | Introduction | 13 |
| 11.2 | Measurements..... | 13 |
| 11.3 | Calculation of f_R | 13 |
| 11.3.1 | Relative rib area | 13 |
| 11.3.2 | Simplified formulae..... | 14 |
| 11.3.3 | Formula used for the calculation of f_R | 14 |
| 11.4 | Calculation of f_P | 15 |
| 11.4.1 | Relative indentation area | 15 |
| 11.4.2 | Simplified formulae..... | 15 |
| 11.4.3 | Formula used for the calculation of f_P | 16 |
| 12 | Determination of deviation from nominal mass per metre..... | 16 |
| 12.1 | Test piece | 16 |
| 12.2 | Accuracy of measurement..... | 16 |
| 12.3 | Test procedure | 16 |
| 13 | Test report | 17 |
| | Bibliography..... | 18 |

Foreword

ISO (the International Organization for Standardization) is a worldwide federation of national standards bodies (ISO member bodies). The work of preparing International Standards is normally carried out through ISO technical committees. Each member body interested in a subject for which a technical committee has been established has the right to be represented on that committee. International organizations, governmental and non-governmental, in liaison with ISO, also take part in the work. ISO collaborates closely with the International Electrotechnical Commission (IEC) on all matters of electrotechnical standardization.

International Standards are drafted in accordance with the rules given in the ISO/IEC Directives, Part 2.

The main task of technical committees is to prepare International Standards. Draft International Standards adopted by the technical committees are circulated to the member bodies for voting. Publication as an International Standard requires approval by at least 75 % of the member bodies casting a vote.

Attention is drawn to the possibility that some of the elements of this document may be the subject of patent rights. ISO shall not be held responsible for identifying any or all such patent rights.

ISO 15630-1 was prepared by Technical Committee ISO/TC 17, *Steel*, Subcommittee SC 16, *Steels for the reinforcement and prestressing of concrete*.

This second edition cancels and replaces the first edition (ISO 15630-1:2002), which has been technically revised.

ISO 15630 consists of the following parts, under the general title *Steel for the reinforcement and prestressing of concrete — Test methods*:

- *Part 1: Reinforcing bars, wire rod and wire*
- *Part 2: Welded fabric*
- *Part 3: Prestressing steel*

Introduction

The aim of ISO 15630 is to provide all relevant test methods for reinforcing and prestressing steels in one standard. In that context, the existing International Standards for testing these products have been revised and updated. Some further test methods have been added.

Reference is made to International Standards on the testing of metals, in general, as they are applicable. Complementary provisions have been given if needed.

Steel for the reinforcement and prestressing of concrete — Test methods —

Part 1: Reinforcing bars, wire rod and wire

1 Scope

This part of ISO 15630 specifies test methods applicable to reinforcing bars, wire rod and wire for concrete.

2 Normative references

The following referenced documents are indispensable for the application of this document. For dated references, only the edition cited applies. For undated references, the latest edition of the referenced document (including any amendments) applies.

ISO 6892-1, *Metallic materials — Tensile testing — Part 1: Method of test at room temperature*

ISO 7500-1, *Metallic materials — Verification of static uniaxial testing machines — Part 1: Tension/compression testing machines — Verification and calibration of the force-measuring system*

ISO 9513, *Metallic materials — Calibration of extensometers used in uniaxial testing*

3 Symbols

The symbols used in this part of ISO 15630 are given in Table 1.

Table 1 — Symbols

| Symbol | Unit | Description | Reference |
|--------------|------|---|--------------------------|
| a' | mm | Height of longitudinal rib | 10.3.2, 11.3 |
| a_m | mm | Rib height at the mid-point or indentation depth in the centre | 10.3.1.2, 11.3.2, 11.4.2 |
| a_{\max}^a | mm | Maximum height of transverse rib or maximum indentation depth | 10.3.1.1 |
| $a_{s,i}$ | mm | Average height of a portion i of a rib subdivided into p parts of length Δl , or average depth of a portion i of an indentation subdivided into p parts of width Δb | 11.3.1, 11.4.1 |
| $a_{1/4}$ | mm | Rib height at the quarter-point or indentation depth at the quarter of their width | 10.3.1.2, 11.3.2, 11.4.2 |
| $a_{3/4}$ | mm | Rib height at the three-quarters point or indentation depth at the three-quarters of their width | 10.3.1.2, 11.3.2, 11.4.2 |
| A | % | Percentage elongation after fracture | 5.1, 5.3 |
| A_g | % | Percentage non-proportional elongation at maximum force (F_m) | 5.3 |

Table 1 (continued)

| Symbol | Unit | Description | Reference |
|----------------|-----------------|--|------------------------------|
| A_{gt} | % | Percentage total elongation at maximum force (F_m) | Clause 5 |
| b | mm | Width of transversal rib at the mid-point or width of indentation | 10.3.8 |
| c | mm | Transverse rib or indentation spacing | 10.3.3, 11.3 |
| d | mm | Nominal diameter of the bar, wire rod or wire | 5.3, 8.2, 8.4.7, 11.3 |
| D | mm | Diameter of the mandrel of the bending device in the bend or rebend test | 6.3, 7.3.2 |
| e | mm | Average gap between two adjacent rib or indentation rows | 10.3.5 |
| f | Hz | Frequency of force cycles in the fatigue test | 8.1, 8.4.3 |
| f_P | — | Relative indentation area | Clause 11 |
| f_R | — | Relative rib area | Clause 11 |
| F_m | N | Maximum force in the tensile test | 5.3 |
| F_P | mm ² | Area of the longitudinal section of one indentation | 11.4.1 |
| F_r | N | Force range in the axial force fatigue test | 8.1, 8.3, 8.4.2, 8.4.3 |
| F_R | mm ² | Area of the longitudinal section of one rib | 11.3.1 |
| F_{up} | N | Upper force in the axial force fatigue test | 8.1, 8.3, 8.4.2, 8.4.3 |
| l | mm | Length of the transverse rib at the rib-core interface | Figure 6 |
| n, m, q, p | — | Quantities used in formulae defining f_R, f_P, F_R and F_P | 11.3, 11.4 |
| P | mm | Pitch for cold-twisted bars | 10.3.4, 11.3 |
| r_1 | mm | Distance between the grips and the gauge length for the manual measurement of A_{gt} | 5.3 |
| r_2 | mm | Distance between the fracture and the gauge length for the manual measurement of A_{gt} | 5.3 |
| R_{eH} | MPa | Upper yield strength | 5.3 |
| R_m | MPa | Tensile strength | 5.3 |
| $R_{p0,2}$ | MPa | 0,2 % proof strength, non-proportional extension | 5.2, 5.3 |
| S_n | mm ² | Nominal cross-sectional area of the bar, rod or wire rod | 8.4.2 |
| α | ° | Transverse rib flank inclination | 10.3.7 |
| β | ° | Angle between the axis of a transverse rib or indentation and the bar, wire rod or wire axis | 10.3.6, 11.3 |
| γ | ° | Angle of bend in the bend or rebend test | 6.3, 7.3.1 (Figure 4), 7.3.2 |
| Δl | mm | Incremental part of the length of the transverse rib at the rib-core interface | Figure 6 |
| δ | ° | Angle of rebend in the rebend test | 7.3.1 (Figure 4), 7.3.4 |
| λ | — | Empirical factor in empirical formulae of f_R and f_P | 11.3.2, 11.4.2 |
| $2\sigma_a$ | MPa | Stress range in the axial force fatigue test | 8.4.2 |
| σ_{max} | MPa | Maximum stress in the axial force fatigue test | 8.4.2 |
| $\sum e_i$ | mm | Part of the circumference without indentation or rib | 10.3.5, 11.3.2, 11.4.2 |

NOTE 1 MPa = 1 N/mm².

^a In some product standards, the symbol h is also used for this parameter.

4 General provisions concerning test pieces

Unless otherwise agreed or specified in the product standard, the test piece shall be taken from the bar, wire rod or wire in the as-delivered condition.

In the case of a test piece taken from coil, the test piece shall be straightened prior to any tests by a bend operation with a minimum amount of plastic deformation.

NOTE The straightness of the test piece is critical for the tensile test and the fatigue test.

The means of straightening the test piece (manual, machine) shall be indicated in the test report¹⁾.

For the determination of the mechanical properties in the tensile test and the fatigue test, the test piece may be artificially aged (after straightening if applicable), depending on the requirements of the product standard.

If the product standard does not specify the ageing treatment, the following conditions should be applied: heating the test piece to 100 °C, maintaining at this temperature ± 10 °C for a period of 1 h $^{+15}_0$ min and then cooling in still air to ambient temperature.

If an ageing treatment is applied to the test piece, the conditions of the ageing treatment shall be stated in the test report.

5 Tensile test

5.1 Test piece

In addition to the general provisions given in Clause 4, the free length of the test piece shall be sufficient for the determination of the percentage elongations in accordance with 5.3.

If the percentage elongation after fracture (A) is determined manually, the test piece shall be marked in accordance with ISO 6892-1.

If the percentage total elongation at maximum force (A_{gt}) is determined by the manual method, equidistant marks shall be made on the free length of the test piece (see ISO 6892-1). The distance between the marks shall be 20 mm, 10 mm or 5 mm, depending on the test piece diameter.

5.2 Test equipment

The testing machine shall be verified and calibrated in accordance with ISO 7500-1 and shall be at least of class 1.

If an extensometer is used, it shall be of class 1 in accordance with ISO 9513 for the determination of $R_{p0,2}$; for the determination of A_{gt} , a class 2 extensometer (see ISO 9513) can be used.

Any extensometer used for the determination of the percentage total elongation at maximum force (A_{gt}) shall have a gauge length of at least 100 mm. The gauge length shall be indicated in the test report.

1) For routine tests conducted by the reinforcing steel producers, the test information, including the test piece condition and method of straightening, should be contained within internal documentation.

5.3 Test procedure

The tensile test shall be carried out in accordance with ISO 6892-1. For the determination of $R_{p0,2}$, if the straight portion of the force-extension diagram is limited or not clearly defined, one of the following methods shall be applied:

- the procedure recommended in ISO 6892-1;
- the straight portion of the force-extension diagram shall be considered as the line joining the points corresponding to $0,2F_m$ and $0,5F_m$.

In case of dispute, the second procedure shall be applied.

The test may be considered invalid if the slope of this line differs by more than 10 % from the theoretical value of the modulus of elasticity.

For the calculation of tensile properties (R_{eH} or $R_{p0,2}$, R_m), the nominal cross-sectional area shall be used, unless otherwise specified in the relevant product standard.

Where fracture occurs in the grips or at a distance from the grips less than 20 mm or d (whichever is the greater), the test may be considered as invalid.

For the determination of percentage elongation after fracture (A), the original gauge length shall be 5 times the nominal diameter (d), unless otherwise specified in the relevant product standard. In case of dispute, A shall be determined manually.

For the determination of the percentage total elongation at maximum force (A_{gt}), ISO 6892-1 shall be applied with the following modification:

- if A_{gt} is determined by the manual method after fracture, A_{gt} shall be calculated from the following formula:

$$A_{gt} = A_g + R_m / 2\ 000 \tag{1}$$

where A_g is the percentage non-proportional elongation at maximum force.

The measurement of A_g shall be made on the longer of the two broken parts of the test piece on a gauge length of 100 mm, as close as possible to the fracture but at a distance, r_2 , of at least 50 mm or $2d$ (whichever is the greater) away from the fracture. This measurement may be considered as invalid if the distance, r_1 , between the grips and the gauge length is less than 20 mm or d (whichever is the greater). See Figure 1.

In case of dispute, the manual method shall apply.

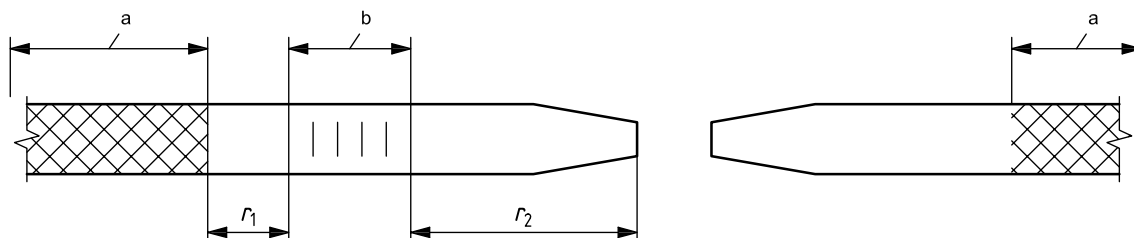

- a Grip length.
- b Gauge length 100 mm.

Figure 1 — Measurement of A_{gt} by the manual method

6 Bend test

6.1 Test piece

The general provisions in Clause 4 apply.

6.2 Test equipment

6.2.1 A bending device, the principle of which is shown in Figure 2, shall be used.

NOTE Figure 2 shows a configuration where the mandrel and support rotate and the carrier is locked. It is also possible that the carrier rotates and the support or mandrel is locked.

6.2.2 The bend test may also be carried out by using a device with supports and a mandrel (e.g. see ISO 7438).

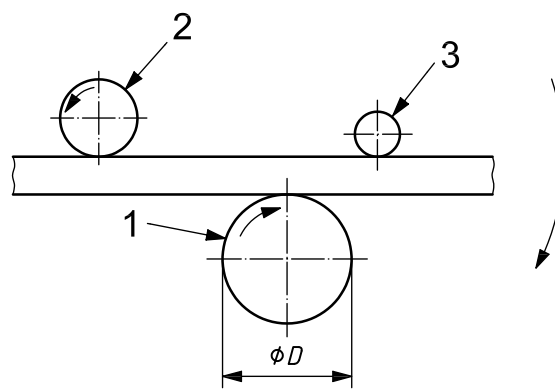

Key

- 1 mandrel
- 2 support
- 3 carrier

Figure 2 — Principle of a bending device

6.3 Test procedure

The bend test shall be carried out at a temperature between 10 °C and 35 °C, unless otherwise agreed by the parties involved.

For testing at a low temperature, if the agreement does not specify all the testing conditions, a deviation of ± 2 °C on the agreed temperature should be applied. The test piece should be immersed in the cooling medium for a sufficient time to ensure that the required temperature is reached throughout the test piece (for example, at least 10 min in a liquid medium or at least 30 min in a gaseous medium). The bend test should start within 5 s from removal from the medium. The transfer device should be designed and used in such a way that the temperature of the test piece is maintained within the temperature range.

The test piece shall be bent over a mandrel.

The angle of bend (γ) and the diameter of the mandrel (D) shall be in accordance with the relevant product standard.

6.4 Interpretation of test results

The interpretation of the bend test shall be carried out in accordance with the requirements of the relevant product standard.

If these requirements are not specified, the absence of cracks visible to a person with normal or corrected vision is considered as evidence that the test piece withstood the bend test.

A superficial ductile tear may occur at the base of the ribs or indentations and is not considered to be a failure. The tear may be considered superficial when the depth of the tear is not greater than the width of the tear.

7 Rebend test

7.1 Test piece

The general provisions given in Clause 4 apply.

7.2 Test equipment

7.2.1 Bending device

A bending device as specified in 6.2 shall be used.

7.2.2 Rebending device

Rebending can be performed on a bending device as shown in Figure 2. An example of an alternative rebending device is shown in Figure 3.

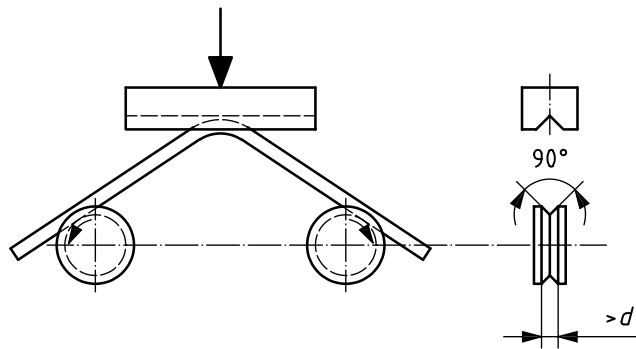

Figure 3 — Example of a rebending device

7.3 Test procedure

7.3.1 General

The test procedure consists of three steps:

- a) bending;
- b) artificial ageing;
- c) rebending.

The test procedure is illustrated in Figure 4.

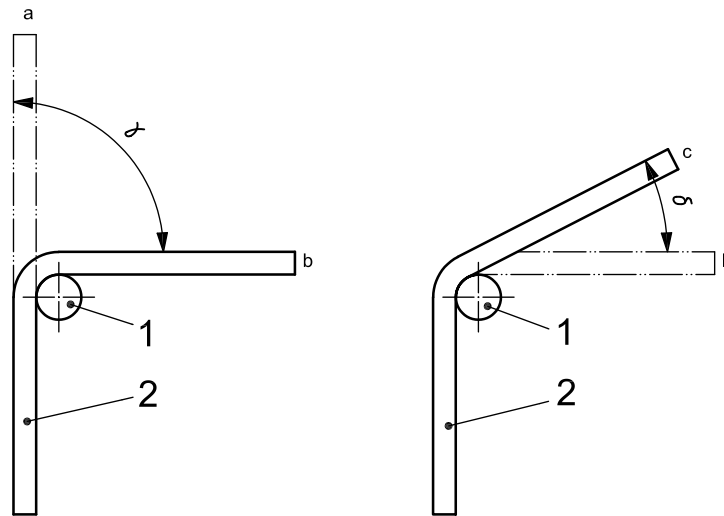

Key

- 1 mandrel
- 2 test piece
- a Initial position.
- b Position after operation described in 7.3.2.
- c Position after operation described in 7.3.4.

Figure 4 — Illustration of the test procedure for rebend tests

7.3.2 Bending

Bending shall be performed at a temperature between 10 °C and 35 °C. The test piece shall be bent over a mandrel.

The angle of bend (γ) and diameter of mandrel (D) shall be in accordance with the relevant product standard.

The test piece shall be carefully inspected for cracks and fissures visible to a person with normal or corrected vision.

7.3.3 Artificial ageing

The temperature and time of artificial ageing shall be in accordance with the relevant product standard.

If the product standard does not specify any ageing treatment, the conditions specified in Clause 4 should be applied.

7.3.4 Rebending

After free cooling in still air to a temperature between 10 °C and 35 °C, the test piece shall be bent back by a specified angle (δ) in accordance with the relevant product standard.

7.4 Interpretation of test results

The interpretation of the rebend test shall be carried out in accordance with the requirements of the relevant product standard.

If these requirements are not specified, absence of cracks visible to a person with a normal or corrected vision is considered as evidence that the test piece has withstood the rebend test.

A superficial ductile tear may occur at the base of the ribs or indentations and is not considered to be a failure. The tear may be considered superficial when the depth of the tear is not greater than the width of the tear.

8 Axial force fatigue test

8.1 Principle of test

The axial force fatigue test consists of submitting the test piece to an axial tensile force, which varies cyclically according to a sinusoidal wave-form of constant frequency f (see Figure 5) in the elastic range. The test is carried out until failure of the test piece or until reaching the number of force cycles specified in the relevant product standard, without failure.

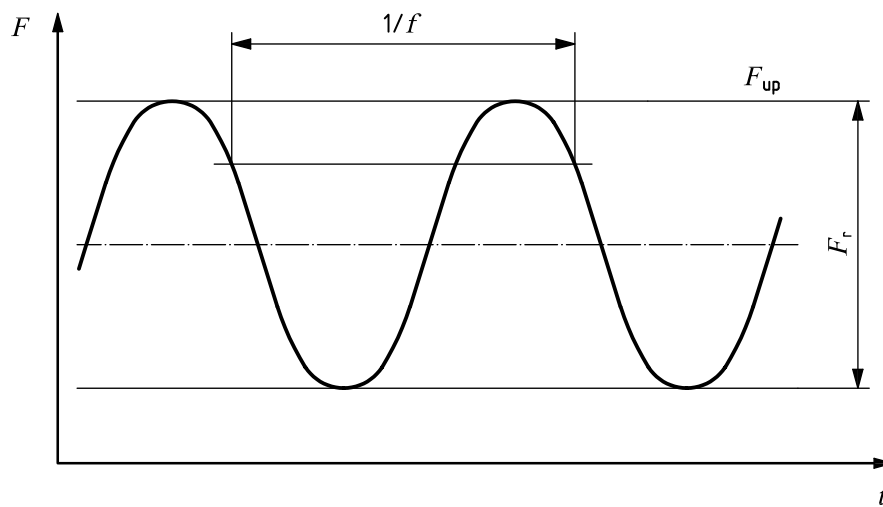

Key

F force

t time

Figure 5 — Force cycle diagram

8.2 Test piece

The general provisions given in Clause 4 apply. For the straightening of the test piece, a production machine may be used.

The surface of the free length between the grips shall not be subjected to any surface treatment of any kind. The free length shall be at least 140 mm or $14d$ (whichever is the greater).

8.3 Test equipment

The fatigue-testing machine shall be calibrated in accordance with ISO 7500-1. The relative error of accuracy shall be less than or equal to $\pm 1\%$. The testing machine shall be capable of maintaining the upper force, F_{up} , within $\pm 2\%$ of the specified value, and the force range, F_r , within $\pm 4\%$ of the specified value.

8.4 Test procedure

8.4.1 Provisions concerning the test piece

The test piece shall be gripped in the test equipment in such a way that force is transmitted axially and free of any bending moment along the test piece.

8.4.2 Upper force (F_{up}) and force range (F_r)

The upper force (F_{up}) and the force range (F_r) shall be as given in the relevant product standard.

NOTE F_{up} and F_r can be deduced from the maximum stress (σ_{max}) and the stress range ($2\sigma_a$) given in the relevant product standard as follows:

$$F_{up} = \sigma_{max} \cdot S_n \quad (2)$$

$$F_r = 2\sigma_a \cdot S_n \quad (3)$$

where S_n is the nominal cross-sectional area of the bar, wire rod or wire.

8.4.3 Stability of force and frequency

The test shall be carried out under conditions of stable upper force (F_{up}), force range (F_r) and frequency (f). There shall be no planned interruptions in the cyclic loading throughout the test. However, it is permissible to continue a test which is accidentally interrupted. Any interruption shall be reported; an interrupted test may be considered as invalid.

8.4.4 Counting of force cycles

The number of force cycles shall be counted inclusively from the first full force-range cycle.

8.4.5 Frequency

The frequency of force cycles shall be stable during the test and also during a series of tests. It shall be between 1 Hz and 200 Hz.

8.4.6 Temperature

The temperature of the test piece shall not exceed 40 °C throughout the test. The temperature of the testing laboratory shall be between 10 °C and 35 °C, unless otherwise specified.

8.4.7 Validity of the test

If failure occurs in the grips or within a distance of $2d$ of the grips, or initiates at an exceptional feature of the test piece, the test may be considered as invalid.

9 Chemical analysis

In general, the chemical composition is determined by spectrometric methods.

In case of dispute about analytical methods, the chemical composition shall be determined by an appropriate reference method specified in one of the relevant International Standards.

NOTE The list of the relevant International Standards for the determination of the chemical composition is given in the Bibliography.

10 Measurement of the geometrical characteristics

10.1 Test piece

The general provisions given in Clause 4 apply.

The length of the test piece shall be sufficient to allow the measurements in accordance with 10.3.

10.2 Test equipment

The geometrical characteristics shall be measured with an instrument of a resolution of at least the following:

- 0,01 mm for the height of transverse or longitudinal ribs and depth of indentations for the measurements less than or equal to 1 mm;
- 0,02 mm for the height of transverse or longitudinal ribs and depth of indentations for the measurements greater than 1 mm;
- 0,05 mm for the gap between the transverse ribs or indentations of two adjacent transverse rib or indentation rows;
- 0,5 mm for the distance between transverse ribs or indentations when determining the transverse rib or indentation spacing (see 10.3.3) or for the distance between two corresponding points of a longitudinal rib of cold-twisted products when determining the pitch (see 10.3.4);
- one degree for the inclination between the transverse rib or indentation and the longitudinal axis of the bar, wire rod or wire or the rib flank inclination.

In cases of dispute, conventional direct-reading instruments, e.g. callipers, depth gauges, shall be used.

10.3 Test procedure

10.3.1 Heights of transverse ribs or depths of indentations

10.3.1.1 Maximum value (a_{\max})

The maximum height of transverse ribs or depth of indentations (a_{\max}) shall be determined as the mean of at least three measurements per row of the maximum height of individual transverse ribs or maximum depth of individual indentations not used for the identification of the bar, wire rod or wire.

10.3.1.2 Value at a given position

The height of transverse ribs or depth of indentations at a given position, e.g. at the quarter-point or at the mid-point or at the three-quarters point, respectively designated $a_{1/4}$, a_m and $a_{3/4}$, shall be determined as the mean of at least three measurements in this position per row on different transverse ribs or indentations not used for the identification of the bar, wire rod or wire.

10.3.2 Height of longitudinal ribs (a')

The height of longitudinal ribs (a') shall be determined as the mean of at least three measurements of the height of each longitudinal rib at three different positions.

10.3.3 Transverse rib or indentation spacing (c)

The spacing of the transverse ribs or indentations (c) shall be determined from the measured length divided by the number of the rib gaps or protrusions between indentations included in it.

The measured length is deemed to be the interval between the centre of a rib or indentation and the centre of another rib or indentation on the same row of the product determined in a straight line and parallel to the longitudinal axis of the product. The measured length shall be

- at least 10 rib gaps or protrusions between indentations, or
- one pitch length for cold-twisted products.

10.3.4 Pitch (P)

The pitch (P) for cold-twisted bars shall be determined as the mean of the distances between two consecutive corresponding points of a longitudinal rib on the same longitudinal line, for each longitudinal rib.

10.3.5 Part of the circumference without ribs or indentations (Σe_i)

The part of the circumference without ribs or indentations (Σe_i) shall be determined as the sum of the average gap (e) between each pair of two adjacent ribs or indentation rows. The average gap (e) shall be determined from at least three measurements.

10.3.6 Transverse rib or indentation angle (β)

The transverse rib or indentation angle (β) to the longitudinal bar, wire rod or wire axis shall be determined as the mean of the individual angles measured for each row of ribs or indentations with the same nominal angle.

10.3.7 Transverse rib flank inclination (α)

Each transverse rib flank inclination (α) shall be determined as the mean of the individual inclinations on the same side of the ribs, measured as indicated in Figure 6 on at least two different transverse ribs per row not used for the identification of the bar, wire rod or wire.

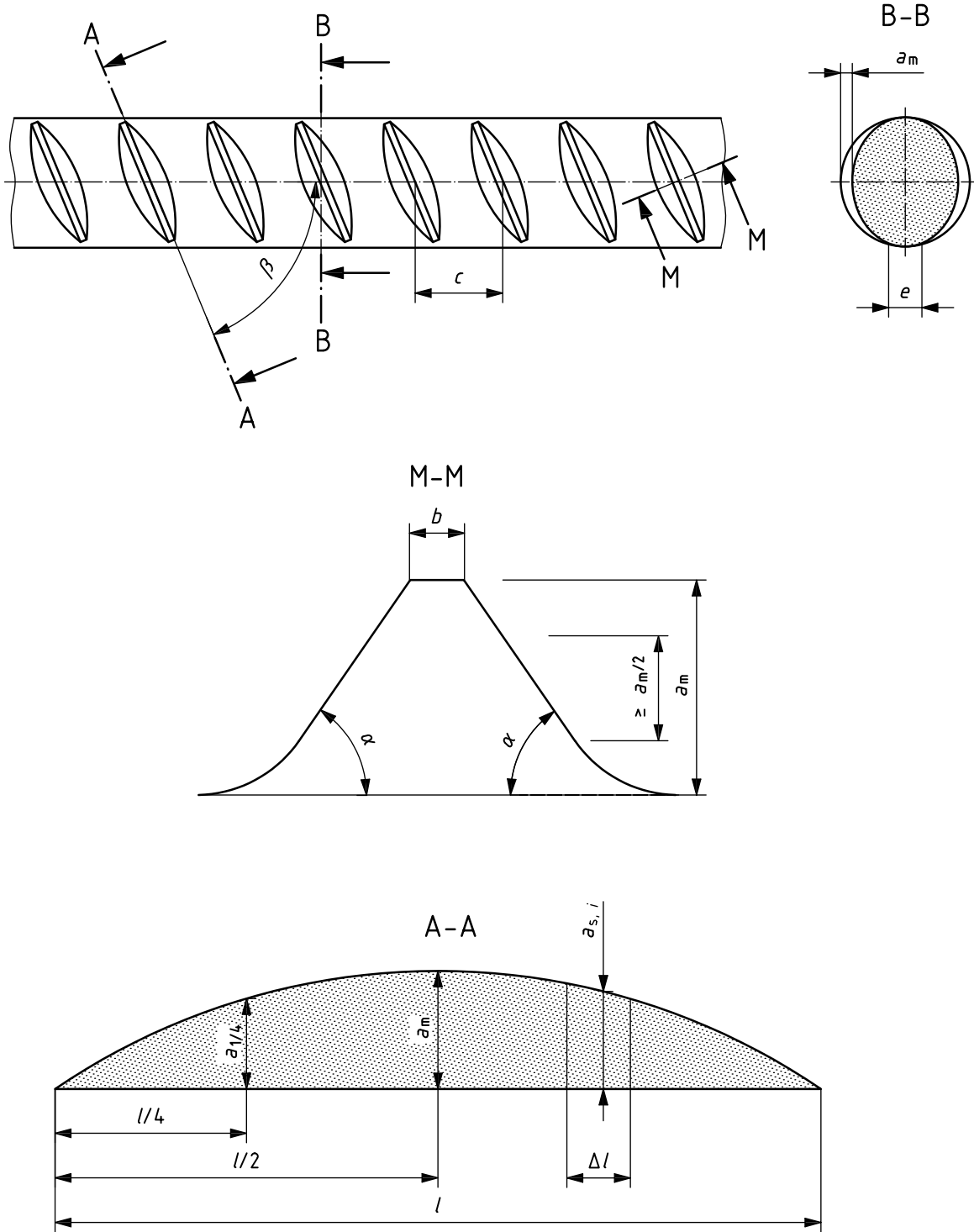

NOTE Section A-A is a flattened representation of a transverse rib.

Figure 6 — Determination of the rib flank inclination (α) and determination of the area of the longitudinal section of one rib (F_R)

The transverse rib flank inclination (α) shall be measured by determining the line of best fit between two points on the slope, far enough apart to give a representation of the inclined angle, but avoiding the slope at the extreme ends of the base and peak of the ribs, e.g. as shown in Figure 6.

10.3.8 Width of transverse rib or width of indentation (b)

The width of transverse rib (b) shall be determined as the mean of three measurements on each row, at the mid-point of the rib, made normal to the axis of the rib. Only ribs which are not used for identification shall be considered.

The width of indentation (b) shall be determined as the mean of three measurements on each row made parallel to the longitudinal axis of the bar, wire rod or wire along a line crossing the indentation at the surface level of the bar, wire rod or wire.

11 Determination of the relative rib or indentation area (f_R or f_P)

11.1 Introduction

The interaction between steel and concrete permits mutual force transfer.

The main effect on bond is given by the shear bond caused by ribs or indentations on the surface of the reinforcing steel.

In the case of ribbed or indented reinforcing steel, the bond behaviour can be determined by different methods:

- measurement of the geometric characteristics of the ribs or indentations;
- measurement of the interaction between the concrete and reinforcing steel in a pull-out test or beam test.

On the basis of the geometric data, a bond factor, called relative rib area (f_R) or relative indentation area (f_P) is computed.

11.2 Measurements

The determination of the relative rib or indentation area (f_R or f_P) shall be carried out using the results of measurements of the geometrical characteristics made in accordance with Clause 10.

11.3 Calculation of f_R

11.3.1 Relative rib area

The relative rib area is defined by the following formula:

$$f_R = \frac{1}{\pi d} \sum_{i=1}^n \frac{\frac{1}{m} \sum_{j=1}^m F_{R,i,j} \sin \beta_{i,j}}{c_i} + \frac{1}{P} \sum_{k=1}^q a'_k \quad (4)$$

where

- n is the number of rows of transverse ribs on the circumference;
- m is the number of different transverse rib inclinations per row;
- q is the number of longitudinal ribs for cold-twisted bars.

$F_R = \sum_{i=1}^p (a_{s,i} \Delta l)$ is the area of the longitudinal section of one rib (see Figure 6), where $a_{s,i}$ is the average height of a portion i of a rib subdivided into p parts of length Δl .

The second summand applies only for cold-twisted bars and shall only be taken into account up to a value of 30 % of the total value of f_R .

11.3.2 Simplified formulae

Where the general formula given in 11.3.1 is not strictly applied by using special devices, a simplified formula may be used.

Examples of simplified formulae are as follows:

a) Trapezium formula:

$$f_R = (a_{1/4} + a_m + a_{3/4})(\pi d - \sum e_i) \frac{1}{4\pi dc} + \frac{1}{P} qa' \quad (5)$$

b) Simpson's rule formula:

$$f_R = (2a_{1/4} + a_m + 2a_{3/4})(\pi d - \sum e_i) \frac{1}{6\pi dc} + \frac{1}{P} qa' \quad (6)$$

c) Parabola formula:

$$f_R = \frac{2a_m}{3\pi dc} (\pi d - \sum e_i) + \frac{1}{P} qa' \quad (7)$$

d) Empirical formula:

$$f_R = \lambda \frac{a_m}{c} \quad (8)$$

where λ is an empirical factor, which may be shown to relate f_R to a_m/c for a particular bar, wire rod or wire profile.

The values $a_{1/4}$, a_m and $a_{3/4}$ shall be determined in accordance with 10.3.1.2.

$\sum e_i$ shall be determined in accordance with 10.3.5.

11.3.3 Formula used for the calculation of f_R

The formula used for the calculation of f_R shall be in accordance with the product standard and be stated in the test report.

11.4 Calculation of f_P

11.4.1 Relative indentation area

The relative indentation area is defined by the following formula:

$$f_P = \frac{1}{\pi d} \sum_{i=1}^n \frac{F_{P,i} \sin \beta_i}{c_i} \tag{9}$$

In this formula, n is the number of indentation rows.

$F_P = \sum_{i=1}^p (a_{s,i} \Delta x)$ is the area of the longitudinal section of one indentation (see Figure 7), where $a_{s,i}$ is the average depth of a portion i of an indentation subdivided into p parts of length Δx .

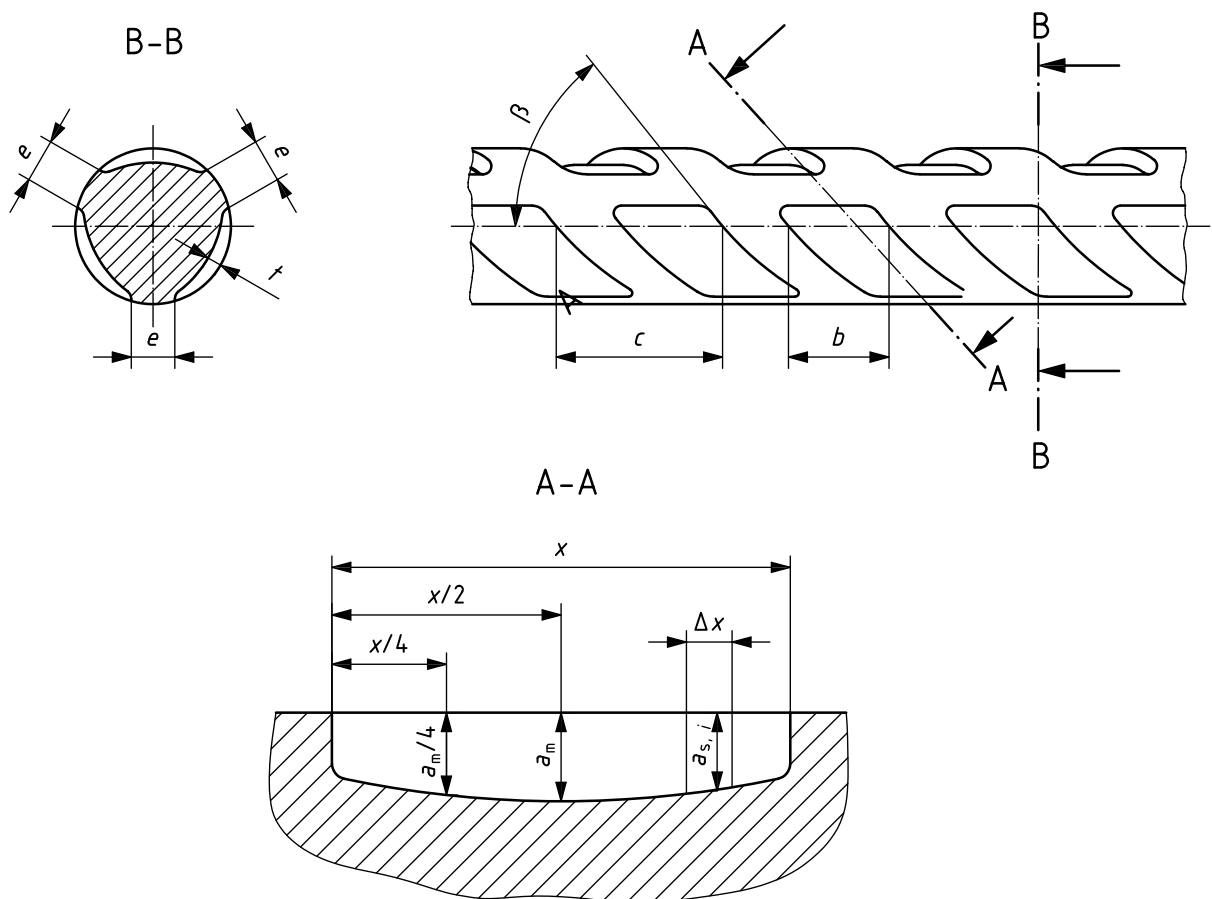

Figure 7 — Determination of the area of the longitudinal section of one indentation F_P

11.4.2 Simplified formulae

Where the general formula given in 11.4.1 is not strictly applied by using special devices, a simplified formula may be used.

Examples of simplified formulae are as follows:

a) Trapezium formula:

$$f_P = (a_{1/4} + a_m + a_{3/4})(\pi d - \sum e_i) \frac{1}{4\pi dc} \quad (10)$$

b) Rectangular formula:

$$f_P = (a_{1/4} + a_m + a_{3/4})(\pi d - \sum e_i) \frac{1}{3\pi dc} \quad (11)$$

c) Parabola formula:

$$f_P = \frac{2a_m}{3\pi dc} (\pi d - \sum e_i) \quad (12)$$

d) Empirical formula:

$$f_P = \lambda \frac{a_m}{c} \quad (13)$$

where λ is an empirical factor, which may be shown to relate f_P to a_m/c for a particular bar, wire rod or wire profile.

The values $a_{1/4}$, a_m and $a_{3/4}$ shall be determined in accordance with 10.3.1.2.

$\sum e_i$ shall be determined in accordance with 10.3.5.

11.4.3 Formula used for the calculation of f_P

The formula used for the calculation of f_P shall be in accordance with the product standard and be stated in the test report.

12 Determination of deviation from nominal mass per metre

12.1 Test piece

The determination of the deviation from nominal mass per metre shall be carried out on a test piece which shall have square-cut ends.

Variations in the rib/indentation profile related to the marking of the reinforcing bar, wire rod and wire may be taken into account to fix the length of the test piece.

12.2 Accuracy of measurement

The length and the mass of the test piece shall be measured with an accuracy of at least $\pm 0,5$ %.

12.3 Test procedure

The percentage deviation from nominal mass per metre shall be determined from the difference between the actual mass per metre of the test piece deduced from its mass and length and the nominal mass per metre as given by the relevant product standard.

13 Test report

The test report shall include at least the following information:

- a) a reference to this part of ISO 15630, i.e. ISO 15630-1:2010;
- b) the identification of the test piece (including the nominal diameter of the bar, wire rod or wire);
- c) the free length of the test piece;
- d) the type of test and the relevant test results;
- e) the relevant product standard, when applicable;
- f) any complementary useful information concerning the test piece, test equipment and procedure.

Bibliography

- [1] ISO 437:1982, *Steel and cast iron — Determination of total carbon content — Combustion gravimetric method*
- [2] ISO 439:1994, *Steel and iron — Determination of total silicon content — Gravimetric method*
- [3] ISO 629:1982, *Steel and cast iron — Determination of manganese content — Spectrophotometric method*
- [4] ISO 671:1982, *Steel and cast iron — Determination of sulphur content — Combustion titrimetric method*
- [5] ISO 4829-1:1986, *Steel and cast iron — Determination of total silicon content — Reduced molybdosilicate spectrophotometric method — Part 1: Silicon contents between 0,05 and 1,0 %*
- [6] ISO 4829-2:1988, *Steel and cast iron — Determination of total silicon content — Reduced molybdosilicate spectrophotometric method — Part 2: Silicon contents between 0,01 and 0,05 %*
- [7] ISO/TR 4830-4:1978, *Steel — Determination of low carbon contents — Part 4: Coulometric method after combustion*
- [8] ISO 4934:2003, *Steel and iron — Determination of sulfur content — Gravimetric method*
- [9] ISO 4935:1989, *Steel and iron — Determination of sulfur content — Infrared absorption method after combustion in an induction furnace*
- [10] ISO 4937:1986, *Steel and iron — Determination of chromium content — Potentiometric or visual titration method*
- [11] ISO 4938:1988, *Steel and iron — Determination of nickel content — Gravimetric or titrimetric method*
- [12] ISO 4939:1984, *Steel and cast iron — Determination of nickel content — Dimethylglyoxime spectrophotometric method*
- [13] ISO 4940:1985, *Steel and cast iron — Determination of nickel content — Flame atomic absorption spectrometric method*
- [14] ISO 4941:1994, *Steel and iron — Determination of molybdenum content — Thiocyanate spectrophotometric method*
- [15] ISO 4942:1988, *Steel and iron — Determination of vanadium content — N-BPHA spectrophotometric method*
- [16] ISO 4943:1985, *Steel and cast iron — Determination of copper content — Flame atomic absorption spectrometric method*
- [17] ISO 4945:1977, *Steel — Determination of nitrogen content — Spectrophotometric method*
- [18] ISO 4946:1984, *Steel and cast iron — Determination of copper content — 2,2'-Diquinolyl spectrophotometric method*
- [19] ISO 4947:1986, *Steel and cast iron — Determination of vanadium content — Potentiometric titration method*
- [20] ISO 7438:2005, *Metallic materials — Bend test*
- [21] ISO 9441:1988, *Steel — Determination of niobium content — PAR spectrophotometric method*

- [22] ISO 9556:1989, *Steel and iron — Determination of total carbon content — Infrared absorption method after combustion in an induction furnace*
- [23] ISO 9647:1989, *Steel and iron — Determination of vanadium content — Flame atomic absorption spectrometric method*
- [24] ISO 9658:1990, *Steel — Determination of aluminium content — Flame atomic absorption spectrometric method*
- [25] ISO 10138:1991, *Steel and iron — Determination of chromium content — Flame atomic absorption spectrometric method*
- [26] ISO 10153:1997, *Steel — Determination of boron content — Curcumin spectrophotometric method*
- [27] ISO 10278:1995, *Steel — Determination of manganese content — Inductively coupled plasma atomic emission spectrometric method*
- [28] ISO 10280:1991, *Steel and iron — Determination of titanium content — Diantiprylmethane spectrometric method*
- [29] ISO 10697-1:1992, *Steel — Determination of calcium content by flame atomic absorption spectrometry — Part 1: Determination of acid-soluble calcium content*
- [30] ISO 10697-2:1992, *Steel — Determination of calcium content by flame atomic absorption spectrometry — Part 2: Determination of total calcium content*
- [31] ISO 10698:1994, *Steel — Determination of antimony content — Electrothermal atomic absorption spectrometric method*
- [32] ISO 10700:1994, *Steel and iron — Determination of manganese content — Flame atomic absorption spectrometric method*
- [33] ISO 10701:1994, *Steel and iron — Determination of sulfur content — Methylene blue spectrophotometric method*
- [34] ISO 10702:1993, *Steel and iron — Determination of nitrogen content — Titrimetric method after distillation*
- [35] ISO 10714:1992, *Steel and iron — Determination of phosphorus content — Phosphovanadomolybdate spectrophotometric method*
- [36] ISO/TR 10719:1994, *Steel and iron — Determination of non-combined carbon content — Infrared absorption method after combustion in an induction furnace*
- [37] ISO 10720:1997, *Steel and iron — Determination of nitrogen content — Thermal conductimetric method after fusion in a current of inert gas*
- [38] ISO 11652:1997, *Steel and iron — Determination of cobalt content — Flame atomic absorption spectrometric method*
- [39] ISO 11653:1997, *Steel — Determination of high cobalt content — Potentiometric titration method after separation by ion exchange*
- [40] ISO 13898-1:1997, *Steel and iron — Determination of nickel, copper and cobalt contents — Inductively coupled plasma atomic emission spectrometric method — Part 1: General requirements and sample dissolution*
- [41] ISO 13898-2:1997, *Steel and iron — Determination of nickel, copper and cobalt contents — Inductively coupled plasma atomic emission spectrometric method — Part 2: Determination of nickel content*

- [42] ISO 13898-3:1997, *Steel and iron — Determination of nickel, copper and cobalt contents — Inductively coupled plasma atomic emission spectrometric method — Part 3: Determination of copper content*
- [43] ISO 13898-4:1997, *Steel and iron — Determination of nickel, copper and cobalt contents — Inductively coupled plasma atomic emission spectrometric method — Part 4: Determination of cobalt content*
- [44] ISO/TS 13899-1:2004, *Steel — Determination of Mo, Nb and W contents in alloyed steel — Inductively coupled plasma atomic emission spectrometric method — Part 1: Determination of Mo content*
- [45] ISO 13899-2:2005, *Steel — Determination of Mo, Nb and W contents in alloyed steel — Inductively coupled plasma atomic emission spectrometric method — Part 2: Determination of Nb content*
- [46] ISO/TS 13899-3:2005, *Steel — Determination of Mo, Nb and W contents in alloyed steel — Inductively coupled plasma atomic emission spectrometric method — Part 3: Determination of W content*
- [47] ISO 13900:1997, *Steel — Determination of boron content — Curcumin spectrophotometric method after distillation*
- [48] ISO 13902:1997, *Steel and iron — Determination of high sulfur content — Infrared absorption method after combustion in an induction furnace*
- [49] ISO/TR 15349-1:1998, *Unalloyed steel — Determination of low carbon content — Part 1: Infrared absorption method after combustion in an electric resistance furnace (by peak separation)*
- [50] ISO 15349-2:1999, *Unalloyed steel — Determination of low carbon content — Part 2: Infrared absorption method after combustion in an induction furnace (with preheating)*
- [51] ISO/TR 15349-3:1998, *Unalloyed steel — Determination of low carbon content — Part 3: Infrared absorption method after combustion in an electric resistance furnace (with preheating)*
- [52] ISO 15350:2000, *Steel and iron — Determination of total carbon and sulfur content — Infrared absorption method after combustion in an induction furnace (routine method)*
- [53] ISO 15351:1999, *Steel and iron — Determination of nitrogen content — Thermal conductimetric method after fusion in a current of inert gas (Routine method)*
- [54] ISO 15353:2001, *Steel and iron — Determination of tin content — Flame atomic absorption spectrometric method (extraction as Sn-SCN)*
- [55] ISO 15355:1999, *Steel and iron — Determination of chromium content — Indirect titration method*
- [56] ISO 16918-1:2009, *Steel and iron — Determination of nine elements by the inductively coupled plasma mass spectrometric method — Part 1: Determination of tin, antimony, cerium, lead and bismuth*
- [57] ISO 17053:2005, *Steel and iron — Determination of oxygen — Infrared method after fusion under inert gas*
- [58] ISO 17054:2010, *Routine method for analysis of high alloy steel by X-ray fluorescence spectrometry (XRF) by using a near-by technique*
- [59] ISO/TR 17055:2002, *Steel — Determination of silicon content — Inductively coupled plasma atomic emission spectrometric method*
- [60] ISO 17058:2004, *Steel and iron — Determination of arsenic content — Spectrophotometric method*

