**Specification and qualification of welding
procedures for metallic materials —
Welding procedure test —**

**Part 3:
Fusion welding of non-alloyed and low-
alloyed cast irons**

*Descriptif et qualification d'un mode opératoire de soudage pour les
matériaux métalliques — Épreuve de qualification d'un mode opératoire
de soudage —*

Partie 3: Soudage par fusion des fontes non alliées et faiblement alliées



PDF disclaimer

This PDF file may contain embedded typefaces. In accordance with Adobe's licensing policy, this file may be printed or viewed but shall not be edited unless the typefaces which are embedded are licensed to and installed on the computer performing the editing. In downloading this file, parties accept therein the responsibility of not infringing Adobe's licensing policy. The ISO Central Secretariat accepts no liability in this area.

Adobe is a trademark of Adobe Systems Incorporated.

Details of the software products used to create this PDF file can be found in the General Info relative to the file; the PDF-creation parameters were optimized for printing. Every care has been taken to ensure that the file is suitable for use by ISO member bodies. In the unlikely event that a problem relating to it is found, please inform the Central Secretariat at the address given below.



COPYRIGHT PROTECTED DOCUMENT

© ISO 2008

All rights reserved. Unless otherwise specified, no part of this publication may be reproduced or utilized in any form or by any means, electronic or mechanical, including photocopying and microfilm, without permission in writing from either ISO at the address below or ISO's member body in the country of the requester.

ISO copyright office
Case postale 56 • CH-1211 Geneva 20
Tel. + 41 22 749 01 11
Fax + 41 22 749 09 47
E-mail copyright@iso.org
Web www.iso.org

Published in Switzerland

Contents

Page

Foreword.....	iv
Introduction	v
1 Scope	1
2 Normative references	1
3 Terms and definitions	2
4 Welding processes	3
5 Preliminary welding procedure specification	3
6 Welding procedure test.....	3
7 Test piece	3
7.1 General.....	3
7.2 Shape and dimensions of test piece	4
7.3 Welding of test piece	4
8 Examination and testing	5
8.1 Extent of testing.....	5
8.2 Location and taking of test specimens	6
8.3 Non-destructive testing.....	6
8.4 Destructive tests	6
8.5 Acceptance criteria.....	7
8.6 Re-testing	7
9 Range of qualification	7
9.1 General.....	7
9.2 Qualification related to the manufacturer	7
9.3 Qualification related to the material.....	8
9.4 Qualification common to all welding procedures	10
9.5 Qualification specific to processes	12
10 Welding procedure qualification record form.....	13
Annex A (informative) Welding procedure qualification record form.....	14
Bibliography	17

Foreword

ISO (the International Organization for Standardization) is a worldwide federation of national standards bodies (ISO member bodies). The work of preparing International Standards is normally carried out through ISO technical committees. Each member body interested in a subject for which a technical committee has been established has the right to be represented on that committee. International organizations, governmental and non-governmental, in liaison with ISO, also take part in the work. ISO collaborates closely with the International Electrotechnical Commission (IEC) on all matters of electrotechnical standardization.

International Standards are drafted in accordance with the rules given in the ISO/IEC Directives, Part 2.

The main task of technical committees is to prepare International Standards. Draft International Standards adopted by the technical committees are circulated to the member bodies for voting. Publication as an International Standard requires approval by at least 75 % of the member bodies casting a vote.

Attention is drawn to the possibility that some of the elements of this document may be the subject of patent rights. ISO shall not be held responsible for identifying any or all such patent rights.

ISO 15614-3 was prepared by the European Committee for Standardization (CEN) Technical Committee CEN/TC 121, *Welding*, in collaboration with Technical Committee ISO/TC 44, *Welding and allied processes*, Subcommittee SC 10, *Unification of requirements in the field of metal welding*, in accordance with the Agreement on technical cooperation between ISO and CEN (Vienna Agreement).

Requests for official interpretations of any aspect of this part of ISO 15614 should be directed to the Secretariat of ISO/TC 44/SC 10 via your national standards body. A complete listing of these bodies can be found at www.iso.org.

ISO 15614 consists of the following parts, under the general title *Specification and qualification of welding procedures for metallic materials — Welding procedure test*:

- *Part 1: Arc and gas welding of steels and arc welding of nickel and nickel alloys*
- *Part 2: Arc welding of aluminium and its alloys*
- *Part 3: Fusion welding of non-alloyed and low-alloyed cast irons*
- *Part 4: Finishing welding of aluminium castings*
- *Part 5: Arc welding of titanium, zirconium and their alloys*
- *Part 6: Arc and gas welding of copper and its alloys*
- *Part 7: Overlay welding*
- *Part 8: Welding of tubes to tube-plate joints*
- *Part 10: Hyperbaric dry welding*
- *Part 11: Electron and laser beam welding*
- *Part 12: Spot, seam and projection welding*
- *Part 13: Resistance butt and flash welding*

Introduction

Details of International Standards dealing with specification and qualification of welding procedures are given in ISO 15607:2003, Annex A.

Welding procedure tests for flash welding are presented in ISO 15614-13 and for friction welding in ISO 15620.

Specification and qualification of welding procedures for metallic materials — Welding procedure test —

Part 3: Fusion welding of non-alloyed and low-alloyed cast irons

1 Scope

This part of ISO 15614 specifies how a preliminary welding procedure specification (pWPS) for production and repair welding of non-alloyed and low-alloyed cast irons is qualified by fusion welding procedure tests.

This part of ISO 15614 defines the conditions for execution of the welding procedure tests and the range of qualification for welding procedures for all practical welding operations within the range of a defined list of variables.

This part of ISO 15614 is applicable to all new welding procedures. However, it does not invalidate previous welding procedure tests made to former national standards or specifications. Where additional tests have to be carried out to make the qualification technically equivalent, it is only necessary to do the additional tests on a test piece made in accordance with this part of ISO 15614.

Additional tests may be required by application standards.

This part of ISO 15614 is applicable to welding non-alloyed and low-alloyed grey cast iron castings according to: EN 1561; EN 1562; EN 1563; and EN 1564.

The principles of this part of ISO 15614 are also applicable for welding cast iron to steel or to other unalloyed and low-alloyed cast iron materials.

2 Normative references

The following referenced documents are indispensable for the application of this document. For dated references, only the edition cited applies. For undated references, the latest edition of the referenced document (including any amendments) applies.

ISO 783, *Metallic materials — Tensile testing at elevated temperature*

ISO 6947, *Welds — Working positions — Definitions of angles of slope and rotation*

ISO 14175, *Welding consumables — Gases and gas mixtures for fusion welding and allied processes*

ISO 15607:2003, *Specification and qualification of welding procedures for metallic materials — General rules*

ISO 15609-1, *Specification and qualification of welding procedures for metallic materials — Welding procedure specification — Part 1: Arc welding*

ISO 15609-2, *Specification and qualification of welding procedures for metallic materials — Welding procedure specification — Part 2: Gas welding*

ISO 15614-3:2008(E)

ISO 15611, *Specification and qualification of welding procedures for metallic materials — Qualification based on previous welding experience*

ISO 15613, *Specification and qualification of welding procedures for metallic materials — Qualification based on pre-production welding test*

EN 571-1, *Non destructive testing — Penetrant testing — Part 1: General principles*

EN 970, *Non-destructive examination of fusion welds — Visual examination*

EN 1011-1, *Welding — Recommendations for welding of metallic materials — Part 1: General guidance for arc welding*

EN 1011-8:2004, *Welding — Recommendations for welding of metallic materials — Part 8: Welding of cast irons*

EN 1321, *Destructive tests on welds in metallic materials — Macroscopic and microscopic examination of welds*

EN 1561, *Founding — Grey cast irons*

EN 1562, *Founding — Malleable cast irons*

EN 1563, *Founding — Spheroidal graphite cast irons*

EN 1564, *Founding — Austempered ductile cast irons*

EN 10002-1, *Metallic materials — Tensile testing — Part 1: Method of test at ambient temperature*

3 Terms and definitions

For the purposes of this document, the terms and definitions given in ISO 15607 and the following apply.

3.1

production welding

any welding carried out during manufacture before final delivery to the end user

3.2

joint welding

production welding used to join components together

3.3

finishing welding

production welding carried out in order to remove casting defects to ensure the required quality of castings

3.4

repair welding

any welding carried out after delivery to the end user, i.e. after the product has been in service

4 Welding processes

Welding is covered by the following welding processes in accordance with ISO 4063:

- 111 manual metal arc welding (metal arc welding with covered electrode); shielded metal arc welding (USA);
- 114 self-shielded tubular-cored arc welding;
- 121 submerged arc welding with one wire electrode;
- 131 metal inert gas welding, MIG welding; gas metal arc welding (USA);
- 135 metal active gas welding, MAG welding; gas metal arc welding (USA);
- 136 tubular-cored metal arc welding with active gas shield; flux cored arc welding (USA);
- 141 tungsten inert gas welding; TIG welding; gas tungsten arc welding (USA);
- 15 plasma arc welding;
- 311 oxy-acetylene welding; oxyacetylene welding (USA).

5 Preliminary welding procedure specification (pWPS)

The pWPS shall be prepared in accordance with ISO 15609-1 or ISO 15609-2.

6 Welding procedure test

The welding and testing of test pieces shall be in accordance with Clauses 7 and 8.

The welder or welding operator, who undertakes the welding procedure test satisfactorily in accordance with this part of ISO 15614, is qualified to weld within the range of qualification according to Clause 9.

7 Test piece

7.1 General

The test piece shall comply with the requirements of 7.2, 7.3, and Figure 1. It can be cast separately or removed from the casting/component. Preparation of sufficiently large test pieces is by machining.

When the standardized test pieces as shown in this part of ISO 15614 do not represent the production/joint geometry, the use of ISO 15611 or ISO 15613 shall be required.

Dimensions in millimetres

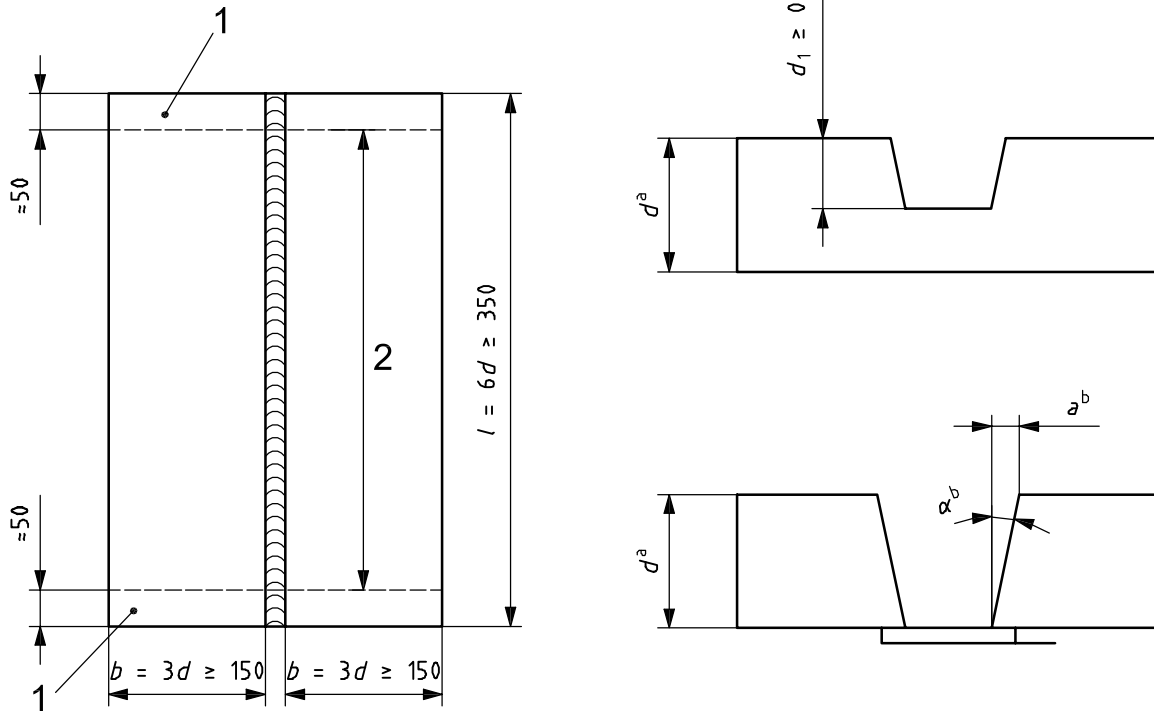

Key

- 1 discard
- 2 inspection length

The dimensions shown are for information only and may be adjusted to meet production and testing requirements. The edges of the groove should be smooth rounded. Edge preparation of the groove and fit-up shall be as detailed in the pWPS.

- a In accordance with Table 3 or Table 4.
- b $a = 5 \text{ mm to } 15 \text{ mm}$ or $\alpha = 5^\circ \text{ to } 20^\circ$.

Figure 1 — Test piece

7.2 Shape and dimensions of test piece

The length or number of test pieces shall be sufficient to allow all required tests to be carried out.

Additional test pieces, or longer test pieces than the minimum size, may be prepared in order to allow for extra and/or for retesting test specimens (see 8.5).

The thickness of the test pieces shall be selected in accordance with 9.3.2.

7.3 Welding of test piece

Preparation and welding of test piece(s) shall be carried out in accordance with a pWPS, and under the general conditions of welding in production which they shall represent. Welding positions and limitations for the angle of slope and rotation of the test piece shall be in accordance with ISO 6947. If tack welds are to be fused into the final joint, they shall be included in the test piece.

Unless otherwise specified in the purchase order or contract review, welding and testing of the test piece(s) shall be witnessed by an examiner (or examining body).

The welds are preferably to be made in flat position (PA). Other welding positions shall be specified. Implementation of the welding should preferably take account of the recommendations in EN 1011-8:2004, Annex B.

8 Examination and testing

8.1 Extent of testing

Testing includes both non-destructive testing (NDT) and destructive testing which shall be in accordance with the requirements of Table 1. Before welding, the grooves shall be subject to visual examination and tested for surface cracks.

An application standard may specify additional tests, e.g.:

- longitudinal weld tensile test;
- bend test;
- corrosion tests;
- chemical analysis;
- impact test;
- radiography or ultrasonic testing;
- hardness test.

NOTE It is possible that specific service, material or manufacturing conditions require more comprehensive testing than is specified by this part of ISO 15614 in order to gain more information and to avoid repeating the welding procedure test at a later date just to obtain additional test data.

Implementation of the tests as well as assessment of the test results are to be undertaken according to the appropriate applicable standards.

Table 1 — Examination and testing of test pieces

Type of test	Material group according to ISO/TR 15608			
	72	71	73	74
	Spheroidal graphite cast iron	Grey cast iron	Malleable cast iron	Austempered ductile cast iron
Visual examination according to EN 970	X	X	X	X
Penetrant testing according to EN 571-1	X	X	X	X
Tensile test at ambient temperature according to EN 10002-1 and ISO 783 with round samples according to EN 10002-1 transverse to the weld (requirement: determination of tensile strength, R_m); other types of sample can be agreed	X	X	X ^a	X
Macroscopic examination transverse to the weld	X	X	X	X
Tensile test at ambient temperature according to EN 10002-1 and ISO 783 with round samples according to EN 10002-1 from the parent metal or according to agreement	X	X	X	X
^a If applicable.				

8.2 Location and taking of test specimens

The test specimens shall be taken in accordance with Figure 2.

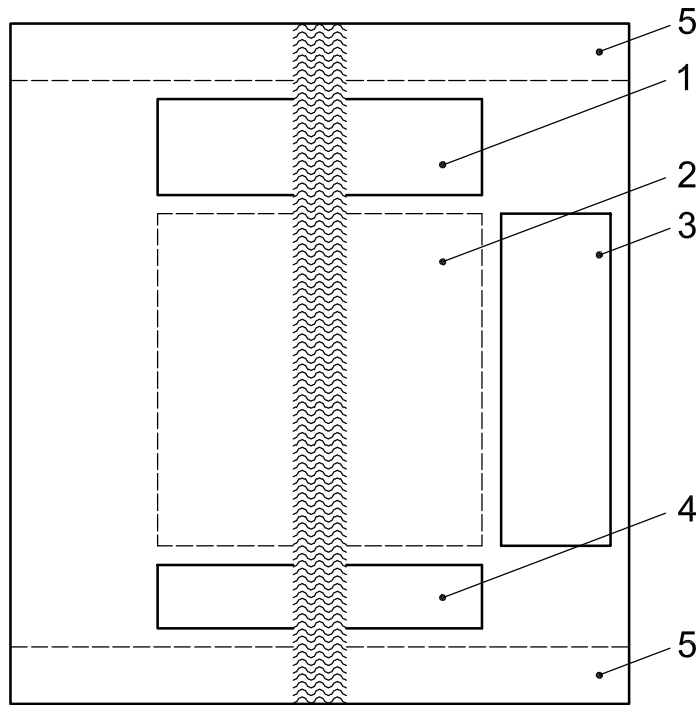

Key

- 1 Area 1 for 1 tensile test specimen
- 2 Area 2 for additional test specimens (e.g. for impact test)
- 3 Area 3 for test specimen from the parent metal
- 4 Area 4 for:
 - a) 1 macro/microscopic test specimen, if required;
 - b) 1 hardness test, if required
- 5 discard 50 mm

Figure 2 — Location of test specimens

8.3 Non-destructive testing

All NDT in accordance with 8.1 and Table 1 shall be carried out on the test pieces prior to taking of the test specimens. Any post-weld heat treatment that is specified shall be completed prior to NDT.

Visual examination shall be carried out according to EN 970 and penetrant testing according to EN 571-1.

8.4 Destructive tests

8.4.1 Extent of testing

The extent of testing shall be as required by Table 1.

8.4.2 Transverse tensile test

Specimens and testing for transverse tensile testing shall be carried out with reference to the relevant material standard. For welds with a thickness < 50 mm, the samples for the tensile test are taken from one plane. With

thicknesses ≥ 50 mm tests should be made in two planes, one somewhat below the surface and the other in the middle of the seam or the root area.

The tensile strength of the test specimen shall be specified prior to testing.

8.4.3 Macroscopic examination

When a macroscopic examination is required, the sample is to be prepared and etched on one side in accordance with EN 1321 in order to clearly show the fusion line and the heat-affected zone (HAZ).

8.4.4 Microscopic examination

When a microscopic examination is required, the sample is to be prepared and etched on one side in accordance with EN 1321 in order to clearly show the fusion line, the HAZ microstructure, and the weld-metal microstructure. The microscopic examination shall include the non-influenced parent metal.

8.5 Acceptance criteria

A welding procedure is qualified if the imperfections in the test piece are within the specified limits for quality level C of EN 1011-8:2004, Annex A.

8.6 Re-testing

If the test piece fails to comply with any of the requirements for visual examination or penetrant testing specified in 8.5, one further test piece shall be welded and subjected to the same examination. If this additional test piece does not comply with the requirements, the welding procedure has failed.

If any test specimen fails to comply with the requirements for destructive testing in accordance with 8.4 but only due to weld imperfections, two further test specimens shall be obtained for each one that failed. The additional test specimens can be taken from the same test piece if there is sufficient material or from a new test piece. Each additional test specimen shall be subjected to the same tests as the initial test specimen that failed. If either of the additional test specimens does not comply with the requirements, the welding procedure test has failed.

If a tensile test specimen fails to meet the requirements of 8.4.2, two further test specimens shall be obtained for each one that failed. Both shall satisfy the requirements of 8.4.2.

9 Range of qualification

9.1 General

Each of the conditions given in Clause 9 shall be met in order to comply with this part of ISO 15614.

Changes outside the ranges specified shall require a new welding procedure test.

9.2 Qualification related to the manufacturer

A qualification of a pWPS by a welding procedure test according to this part of ISO 15614 obtained by a manufacturer is valid for welding in workshops or sites under the same technical and quality control of the manufacturer.

Welding is under the same technical and quality control when the manufacturer who performed the welding procedure test retains complete responsibility for all welding carried out to it.

9.3 Qualification related to the material

9.3.1 Parent material

In order to minimize the number of welding procedure tests, material grades shall be grouped as shown in Table 2.

For spheroidal graphite cast iron, a procedure test carried out on one grade of cast iron is valid for other types.

For grey and malleable cast irons, the procedure test carried out on the chosen grade of cast iron is valid for all grades, while a lower grade A procedure test on austempered ductile cast iron is only valid for this grade of cast iron used in the welding procedure test.

A separate welding procedure qualification shall be obtained for each cast iron not covered by the grouping system.

Table 2 — Range of qualification for spheroidal graphite cast iron

Material	Parent material group (ISO/TR 15608)	Non-homogeneous filler metal	Homogeneous/semi-homogeneous filler metal
Grey cast irons	71		
Spheroidal cast irons (ferrite type with specified impact resistance values)	72.2		
Spheroidal cast irons (ferrite type)	72.1		
Spheroidal cast irons (ferrite/perlite type)	72.1		
Spheroidal cast irons (perlite type)	72.1		
Malleable cast irons	73		
Austempered ductile cast irons	74		

Procedure test for chosen grade is valid for all grades with lower strength in this group

Procedure test for chosen grade from this group is valid for all ferritic grades with higher strength in this group up to group 72.1 EN-GJS-400-15, resp. EN-GJS-450-10 if ferritic

The grades EN-GJS-500-7 and EN-GJS-450-10 need to have separate procedure tests

Procedure test for chosen perlite grade from this group is valid for all grades with lower strength down to EN-GJS-600-3

Procedure test for chosen grade is valid for all lower grades in this group (see Table 4)

A procedure test on austempered ductile cast iron is only valid for the grade of cast iron used in the welding procedure under consideration of the chosen heat treatment

9.3.2 Parent material thickness

The qualification of welding procedure test on thickness, t , shall include thicknesses in the range of qualification given in Tables 3 and 4.

Table 3 — Range of qualification for thickness

Test piece thickness, t mm	Range of qualification
$15 < t \leq 30$	3 mm to $2t$
$t > 30$	$0,5t$ to $2t$ or 200 mm, whichever is greater

Table 4 — Range of qualification of thickness for special cases

Material of test piece	Thickness of test piece mm	Range of qualification mm	Remarks
EN-GJMW-360-12	$3 < t \leq 8$	$3 < t \leq 8$	C mass fraction $\leq 0,3$ %
	$8 < t \leq 12$	$8 < t \leq 12$	No free carbon yet, but perlite mass fraction up to 100 % in core region
	$12 < t \leq 30$	$12 < t \leq 60$	In addition, segregations of temper carbon in core region
EN-GJMW-400-5 EN-GJMW-450-7	$t \leq 3$	$t \leq 3$	C mass fraction $\leq 0,3$ %
	$3 < t \leq 5$	$3 < t \leq 5$	No free carbon yet, but perlite mass fraction up to 100 % in core region
	$5 < t < 30$	$5 < t < 60$	In addition, segregations of temper carbon in core region
EN-GJMW-550-4	$3 < t < 30$	$3 < t < 60$	Low decarburization, therefore temper carbon in thin sections as well
EN-GJMB-350-10	$3 < t < 30$	$3 < t < 60$	No decarburization, temper carbon segregation even in thinnest sections

9.4 Qualification common to all welding procedures

9.4.1 Welding processes

The qualification according to the welding procedure specification (WPS) is valid only for the welding process used in the welding procedure test. In a multi-process procedure test, the qualification is valid only for the sequence used during the qualification test.

For multi-process procedures, each welding process may be approved separately or in combination with other processes. Similarly one or more processes may be deleted from an approved WPS provided the joint thickness is within the approved thickness range of the relevant welding process(es) to be applied.

9.4.2 Welding positions

When neither impact nor other dynamic tests are specified, welding in any one position approves for welding in all positions.

When impact tests and/or other dynamic tests are specified for a weld, the range of qualification according to Table 5 shall be applied.

Welding in one welding position qualifies for other welding positions according to Table 5.

Table 5 — Welding positions

Welding position of test piece (ISO 6947)	Range of qualification			
	PA	PC	PF	PE
PA (flat)	X	—	—	—
PC (horizontal)	X	X	—	—
PF (vertical up)	X	X	X	—
PE (overhead)	X	X	X	X

9.4.3 Type of joint/weld

A qualification established using the arrangements shown in Figure 1 is valid for all types of butt weld (joint and/or finishing welding).

A welding procedure test single sided weld without backing is valid both for side welding and for welds with backing.

9.4.4 Filler material

The qualification range of filler metals shall meet the requirements of the materials listed in Table 2.

9.4.5 Type of current

The qualification given is only for the type of current (AC, DC, pulsed current) and polarity used in the welding procedure test.

9.4.6 Heat input

When impact requirements apply, the upper limit of heat input qualified is 25 % greater than that used in welding the test piece.

When hardness requirements apply, the lower limit of heat input qualified is 25 % lower than that used in welding the test piece.

Heat input is calculated in accordance with EN 1011-1.

If welding procedure tests have been performed at both a high and a low heat input level, then all intermediate heat inputs are also qualified.

9.4.7 Preheat temperature

The lower limit of qualification is the nominal preheat temperature applied at the start of the welding procedure test.

9.4.8 Interpass temperature

The upper limit of qualification is the nominal interpass temperature reached in the welding procedure test.

9.4.9 Post-weld heat treatment

Addition or deletion of post-weld heat treatment is not permitted.

The temperature range validated is the holding temperature used in the welding procedure test ± 20 °C unless otherwise specified. Where required, heating rates, cooling rates and holding time shall be related to the product.

9.5 Qualification specific to processes

9.5.1 Process 111

The qualification given is for the diameter of electrode, d_e , used in the welding procedure test, $\pm d_e$ for each run, with the exception of the root run on single side welding without backing butt welds for which no size change is permissible.

9.5.2 Process 121

The qualification given is restricted to the wire system used in the welding procedure test (e.g. single-wire or multiple-wire system).

The qualification given for the flux or wire type and combination is restricted to the conditions of the weld procedure test.

9.5.3 Processes 131, 135, 136, and 137

The qualification given to the shielding gas is restricted to the symbol of the gas according to ISO 14175. However, the carbon dioxide volume fraction shall not exceed 10 % of that used to qualify the welding procedure test. Shielding gases not covered by ISO 14175 are restricted to the nominal composition used in the test.

The qualification given is restricted to the wire system used in the welding procedure test (e.g. single-wire or multi-wire system).

9.5.4 Process 141

The qualification given to the shielding gas and backing gas is restricted to the symbol of the gas according to ISO 14175. Shielding gases not covered by ISO 14175 are restricted to the nominal composition used in the test.

A welding procedure test made without a backing gas qualifies a welding procedure test with backing gas.

Welding with filler material does not qualify for welding without filler material or vice versa.

9.5.5 Process 15

Qualification of the welding procedure is restricted to the plasma gas composition used in the welding procedure test.

The qualification given to the shielding gas and backing gas is restricted to the symbol of the gas according to ISO 14175. Shielding gases not covered by ISO 14175 are restricted to the nominal composition qualified.

Welding with filler material does not qualify for welding without filler material or vice versa.

9.5.6 Process 311

Welding with filler material does not qualify for welding without filler material or vice versa.

10 Welding procedure qualification record form

The welding procedure qualification record (WPQR) is a statement of the results of assessing each test piece including re-tests. The relevant items listed for the WPS in ISO 15609-1 or ISO 15609-2 shall be included, together with details of any features that would be rejectable by the requirements of Clause 8. If no rejectable features or unacceptable test results are found, a WPQR detailing the welding procedure test piece results is qualified and shall be signed and dated by the examiner or examining body.

A WPQR format shall be used to record details for the welding procedure and the test results, in order to facilitate uniform presentation and assessment of the data.

An example of a WPQR format is shown in Annex A.

Annex A
(informative)

Welding procedure qualification record form

Welding procedure qualification — Test certificate

Manufacturer's WPQR No.: Examiner or examining body:

Manufacturer: Reference No.:

Address:

Code/testing standard:

Date of welding:

Range of qualification

Welding process(es):

Type of joint and weld:

Parent material group(s) and sub group(s):

Parent material thickness (mm):

Weld-metal thickness (mm):

Throat thickness (mm):

Single run/multi-run:

Outside pipe diameter (mm):

Filler material designation:

Filler material make:

Filler material size:

Designation of shielding gas/flux:

Designation of backing gas:

Type of welding current and polarity:

Mode of metal transfer:

Heat input:

Welding positions:

Preheat temperature:

Interpass temperature:

Post-heating:

Post-weld heat treatment:

Other information (see also 8.5):

Certified that test welds prepared, welded and tested satisfactorily in accordance with the requirements of the code/testing standard indicated above.

.....
Location

.....
Date of issue

.....
Examiner or examining body
Name, date and signature

Record of weld test

Location: Examiner or examining body:
 Manufacturer's pWPS No.: Method of preparation and cleaning:
 Manufacturer's WPQR No.: Parent material specification:
 Manufacturer: Material thickness (mm):
 Welder's name: Outside pipe diameter (mm):
 Mode of metal transfer: Welding position:
 Joint type and weld:
 Weld preparation details (sketch)*:

Joint design	Welding sequences

Welding details

Run	Welding process	Size of filler material	Current A	Voltage V	Type of current/polarity	Wire feed speed	Travel speed*	Heat input*	Metal transfer

Filler material designation and make:
 Any special baking or drying:
 Gas/flux — shielding:
 — backing:
 Gas flow rate — shielding:
 — backing:
 Tungsten electrode type/size:
 Details of back gouging/backing:
 Preheat temperature:
 Interpass temperature:
 Post-heating:
 Post-weld heat treatment:
 (time, temperature, method,
 heating and cooling rates*):

Other information* e.g.:
 Weaving (maximum width of run):
 Oscillation: amplitude, frequency, dwell time:
 Pulse welding details:
 Distance contact tube/ workpiece:
 Plasma welding details:
 Torch angle:

.....
 Manufacturer
 Name, date and signature

.....
 Examiner or examining body
 Name, date and signature

*If required.

Test results

Manufacturer's WPQR No.:

Examiner or examining body:

Visual:

Reference No.*:

Penetrant/magnetic particle*:

Radiography*:

Ultrasonic*:

Tensile tests

Temperature:

Type/No.	Yield strength, R_e MPa	Tensile strength, R_m MPa	Elongation after fracture, A %	Reduction of area, Z %	Fracture location	Remarks
Requirement						

Bend tests

Former diameter:

Type/No.	Bend angle	Elongation*	Results

Macroscopic Examination:

Impact test*

Type:

Size:

Requirements:

Notch location/direction	Temp. °C	Values			Average	Remarks
		1	2	3		

Hardness test* (type/load):

Location of measurements (sketch*):

Parent metal:

HAZ:

Weld metal:

Other tests:

Remarks:

Tests carried out in accordance with the requirements of:

Laboratory report reference No.:

Test results were (delete as appropriate):

acceptable;

not acceptable.

Test carried out in the presence of:

* If required.

.....
Examiner or examining body

Name, date and signature

Bibliography

- [1] ISO 4063, *Welding and allied processes — Nomenclature of processes and reference numbers*
- [2] ISO/TR 15608, *Welding — Guidelines for a metallic materials grouping system*
- [3] ISO 15614-13, *Specification and qualification of welding procedures for metallic materials — Welding procedure test — Part 13: Resistance butt and flash welding*
- [4] ISO 15620, *Welding — Friction welding of metallic materials*

ICS 25.160.10

Price based on 17 pages