

---

---

**Specification and qualification of  
welding procedures for metallic  
materials — Welding procedure test —**

**Part 14:  
Laser-arc hybrid welding of steels,  
nickel and nickel alloys**

*Descriptif et qualification d'un mode opératoire de soudage pour  
les matériaux métalliques — Épreuve de qualification d'un mode  
opératoire de soudage —*

*Partie 14: Soudage hybride laser-arc des aciers, du nickel et des  
alliages de nickel*





**COPYRIGHT PROTECTED DOCUMENT**

© ISO 2013

All rights reserved. Unless otherwise specified, no part of this publication may be reproduced or utilized otherwise in any form or by any means, electronic or mechanical, including photocopying, or posting on the internet or an intranet, without prior written permission. Permission can be requested from either ISO at the address below or ISO's member body in the country of the requester.

ISO copyright office  
Case postale 56 • CH-1211 Geneva 20  
Tel. + 41 22 749 01 11  
Fax + 41 22 749 09 47  
E-mail [copyright@iso.org](mailto:copyright@iso.org)  
Web [www.iso.org](http://www.iso.org)

Published in Switzerland

# Contents

	Page
<b>Foreword</b> .....	<b>iv</b>
<b>Introduction</b> .....	<b>v</b>
<b>1 Scope</b> .....	<b>1</b>
<b>2 Normative references</b> .....	<b>1</b>
<b>3 Terms and definitions</b> .....	<b>2</b>
<b>4 Preliminary welding procedure specification</b> .....	<b>2</b>
<b>5 Welding procedure test</b> .....	<b>3</b>
<b>6 Test piece</b> .....	<b>3</b>
6.1 General.....	3
6.2 Shape and dimensions of test pieces.....	3
6.3 Welding of test pieces.....	4
<b>7 Examination and testing</b> .....	<b>8</b>
7.1 Extent of examination and testing.....	8
7.2 Location and taking of test specimens.....	9
7.3 Non-destructive testing.....	14
7.4 Destructive testing.....	14
7.5 Quality levels.....	16
7.6 Re-testing.....	17
<b>8 Range of qualification</b> .....	<b>17</b>
8.1 General.....	17
8.2 Related to the manufacturer.....	17
8.3 Related to the parent material.....	17
8.4 Related to welding process.....	21
8.5 Related to welding position.....	21
8.6 Related to type of joint or weld.....	21
8.7 Related to number of layers.....	21
8.8 Related to filler material.....	21
8.9 Related to type of current.....	21
8.10 Related to preheating and interpass temperature.....	21
8.11 Related to post-weld heat treatment.....	21
8.12 Nominal heat input.....	22
8.13 Duration of validity.....	22
<b>9 Welding procedure qualification record (WPQR)</b> .....	<b>22</b>
<b>Annex A (informative) Welding procedure qualification record template (WPQR)</b> .....	<b>23</b>
<b>Bibliography</b> .....	<b>24</b>

## Foreword

ISO (the International Organization for Standardization) is a worldwide federation of national standards bodies (ISO member bodies). The work of preparing International Standards is normally carried out through ISO technical committees. Each member body interested in a subject for which a technical committee has been established has the right to be represented on that committee. International organizations, governmental and non-governmental, in liaison with ISO, also take part in the work. ISO collaborates closely with the International Electrotechnical Commission (IEC) on all matters of electrotechnical standardization.

International Standards are drafted in accordance with the rules given in the ISO/IEC Directives, Part 2.

The main task of technical committees is to prepare International Standards. Draft International Standards adopted by the technical committees are circulated to the member bodies for voting. Publication as an International Standard requires approval by at least 75 % of the member bodies casting a vote.

Attention is drawn to the possibility that some of the elements of this document may be the subject of patent rights. ISO shall not be held responsible for identifying any or all such patent rights.

ISO 15614-14 was prepared by Technical Committee ISO/TC 44, *Welding and allied processes*, Subcommittee SC 10, *Unification of requirements in the field of metal welding*.

ISO 15614 consists of the following parts, under the general title *Specification and qualification of welding procedures for metallic materials — Welding procedure test*:

- *Part 1: Arc and gas welding of steels and arc welding of nickel and nickel alloys*
- *Part 2: Arc welding of aluminium and its alloys*
- *Part 3: Fusion welding of non-alloyed and low-alloyed cast irons*
- *Part 4: Finishing welding of aluminium castings*
- *Part 5: Arc welding of titanium, zirconium and their alloys*
- *Part 6: Arc and gas welding of copper and its alloys*
- *Part 7: Overlay welding*
- *Part 8: Welding of tubes to tube-plate joints*
- *Part 10: Hyperbaric dry welding:*
- *Part 11: Electron and laser beam welding*
- *Part 12: Spot, seam and projection welding*
- *Part 13: Upset (resistance butt) and flash welding*
- *Part 14: Laser-arc hybrid welding of steels, nickel and nickel alloys*

Requests for official interpretations of any aspect of this part of ISO 15614 should be directed to the Secretariat of ISO/TC 44/SC 10 via your national standards body. A complete listing of these bodies can be found at [www.iso.org](http://www.iso.org).

## Introduction

It is intended that all new welding procedure tests be carried out in accordance with this part of ISO 15614 from the date of its issue.

However, this part of ISO 15614 does not invalidate previous welding procedure tests made to former national standards or specifications.

Also, where additional tests shall be carried out to make the qualification technically equivalent, it is only necessary to do the additional tests on a test piece made in accordance with this part of ISO 15614.

\*\*\*\*\*

# Specification and qualification of welding procedures for metallic materials — Welding procedure test —

## Part 14: Laser-arc hybrid welding of steels, nickel and nickel alloys

### 1 Scope

This part of ISO 15614 specifies how a preliminary welding procedure specification is qualified by welding procedure tests.

This part of ISO 15614 defines the conditions for the execution of welding procedure tests and the range of qualification for welding procedures for all practical welding operations within the range of variables listed in [Clause 8](#).

NOTE 1 It is possible that additional tests are required by applications standards.

NOTE 2 The various parts of ISO 15614 comprise, in their turn, a series of International Standards on welding, details of which are given in ISO 15607:2003, Annex A.

### 2 Normative references

The following referenced documents, in whole or in part, are normatively referenced in this document and are indispensable for its application. For dated references, only the edition cited applies. For undated references, the latest edition of the referenced document (including any amendments) applies.

ISO 3452-1, *Non-destructive testing — Penetrant testing — Part 1: General principles*

ISO 4136, *Destructive tests on welds in metallic materials — Transverse tensile test*

ISO 5173, *Destructive tests on welds in metallic materials — Bend tests*

ISO 6947, *Welding and allied processes — Welding positions*

ISO 9016, *Destructive tests on welds in metallic materials — Impact tests — Test specimen location, notch orientation and examination*

ISO 12932, *Welding — Laser-arc hybrid welding of steels, nickel and nickel alloys — Quality levels for imperfections*

ISO 14732, *Welding personnel — Qualification testing of welding operators and weld setters for mechanized and automatic welding of metallic materials*

ISO 15607:2003, *Specification and qualification of welding procedures for metallic materials — General rules*

ISO/TR 15608, *Welding — Guidelines for a metallic materials grouping system*

ISO 15609-6, *Specification and qualification of welding procedures for metallic materials — Welding procedure specification — Part 6: Laser-arc hybrid welding*

ISO 15613, *Specification and qualification of welding procedures for metallic materials — Qualification based on pre-production welding test*

ISO 17636 (all parts), *Non-destructive testing of welds — Radiographic testing*

ISO 17637, *Non-destructive testing of welds — Visual testing of fusion-welded joints*

ISO 17638, *Non-destructive testing of welds — Magnetic particle testing*

ISO 17639, *Destructive tests on welds in metallic materials — Macroscopic and microscopic examination of welds*

ISO 17640, *Non-destructive testing of welds — Ultrasonic testing — Techniques, testing levels, and assessment*

### 3 Terms and definitions

For the purposes of this document, the terms and definitions given in ISO 15607 and the following apply.

#### 3.1 hybrid welding

welding in which two or more welding processes are used simultaneously in the same weld pool

Note 1 to entry: Hybrid welding is different than combinations of processes where at least two melt pools exist which are completely separated by a solid component in the solidification phases. Examples of a combined process (a) and a laser-arc hybrid welding process (b) are given in [Figure 1](#) by using a laser beam and the additional energy source of an arc.

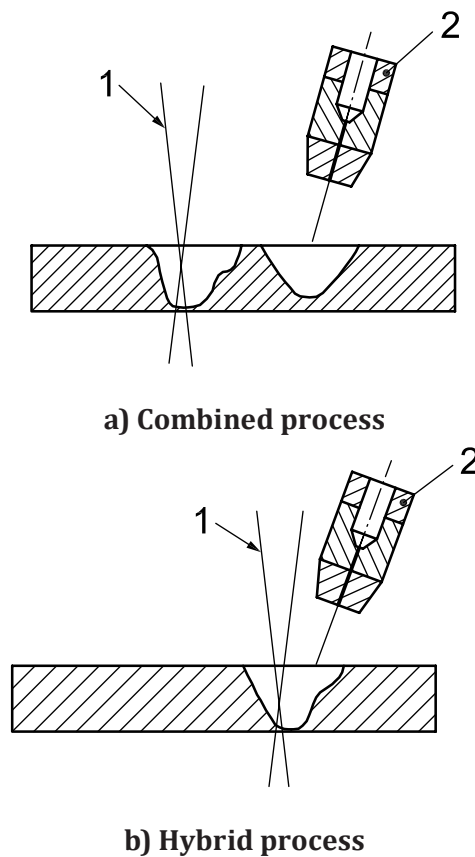

- Key**
- 1 laser beam
  - 2 torch

**Figure 1 — Combination of welding processes**

### 4 Preliminary welding procedure specification

The preliminary welding procedure specification (pWPS) shall be prepared in accordance with ISO 15609-6.



## 5 Welding procedure test

The welding and testing of test pieces shall be in accordance with [Clauses 6](#) and [7](#).

The welding operator who undertakes the welding procedure test satisfactorily in accordance with this part of ISO 15614 shall be qualified for the appropriate range of qualification in accordance with ISO 14732 provided the relevant testing requirements are met.

## 6 Test piece

### 6.1 General

The welded joint to which the welding procedure relates in production shall be represented by making a standardized test piece or pieces, as specified in [6.2](#). Where the production joint geometry requirements do not represent the standardized test piece as shown in this part of ISO 15614, the use of ISO 15613 shall be required.

The length or number of test pieces shall be sufficient to allow all required tests to be carried out.

Additional test pieces, or longer test pieces than the minimum size, can be prepared in order to allow for extra or for re-testing specimens (see [7.6](#)). Application standards can require larger test pieces.

If required by the application standard, the direction of plate rolling shall be marked on the test piece when impact tests are required to be taken in the heat-affected zone (HAZ).

The plate thickness or pipe outside diameter and wall thickness of the test pieces shall be selected in accordance with [8.3.2.1](#) to [8.3.2.3](#).

### 6.2 Shape and dimensions of test pieces

#### 6.2.1 Butt joint in plate

The test piece shall be prepared in accordance with [Figure 2](#).

It may be used for fully and partially penetrated butt welds.

#### 6.2.2 Butt joint in pipe

The test piece shall be prepared in accordance with [Figure 3](#).

It may be used for fully and partially penetrated butt welds.

NOTE The word “pipe”, alone or in combination, is used to mean “pipe”, “tube” or “hollow section”.

#### 6.2.3 T-joint

The test piece shall be prepared in accordance with [Figure 4](#).

It may be used for fully and partially penetrated butt welds or fillet welds.

#### 6.2.4 Corner joint

The test piece shall be prepared in accordance with [Figure 5](#).

It may be used for fully and partially penetrated butt welds or fillet welds.

### 6.2.5 Branch connection

The pipe to pipe test piece shall be prepared in accordance with [Figure 6](#). The angle  $\alpha$  is the minimum to be used in production.

It may be used for fully and partially penetrated joints (set-on or set-in or set-through joint) and for fillet welds.

The pipe to plate test piece shall be prepared in accordance with [Figure 7](#). The angle  $\alpha$  is the minimum to be used in production.

It may be used for fully and partially penetrated joints (set-on or set-in or set-through joint) and for fillet welds.

### 6.3 Welding of test pieces

Preparation and welding of test pieces shall be carried out in accordance with the pWPS, and under the general conditions of welding in production which they shall represent. Welding positions and limitations for the angle of slope and rotation of the test piece shall be in accordance with ISO 6947. If tack welds are to be fused into the final joint, they shall be included in the test piece.

Welding and testing of the test pieces shall be witnessed by an examiner or an examining body.

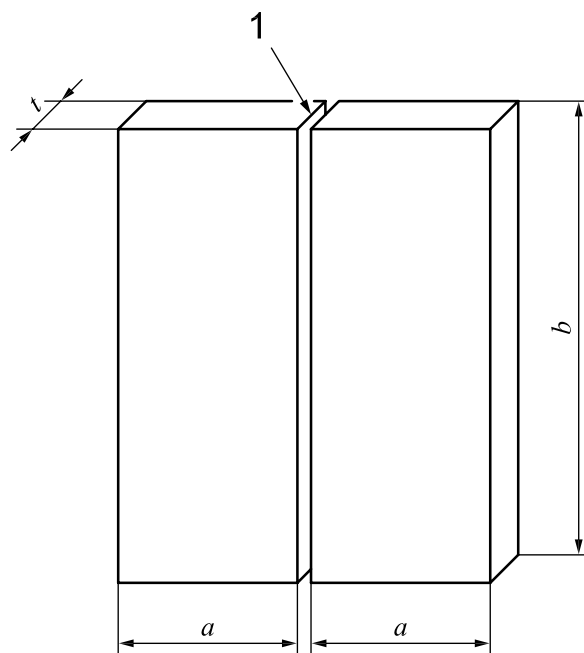

#### Key

- 1 joint preparation and fit-up as detailed in the pWPS
- $t$  material thickness
- $a$  Minimum width 150 mm.
- $b$  Minimum length 350 mm.

**Figure 2 — Test piece for a butt joint in plate**

.....

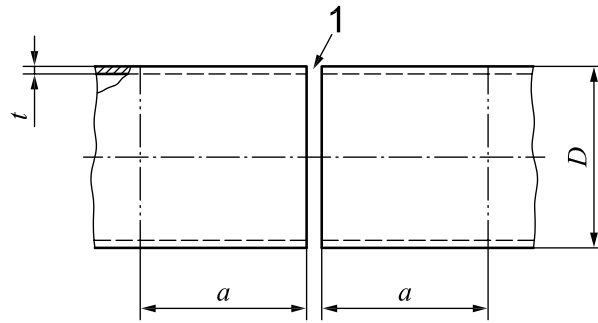

**Key**

- 1 joint preparation and fit-up as detailed in the pWPS
- $a$  minimum length 150 mm
- $D$  outside pipe diameter
- $t$  material thickness

**Figure 3 — Test piece for a butt joint in pipe**

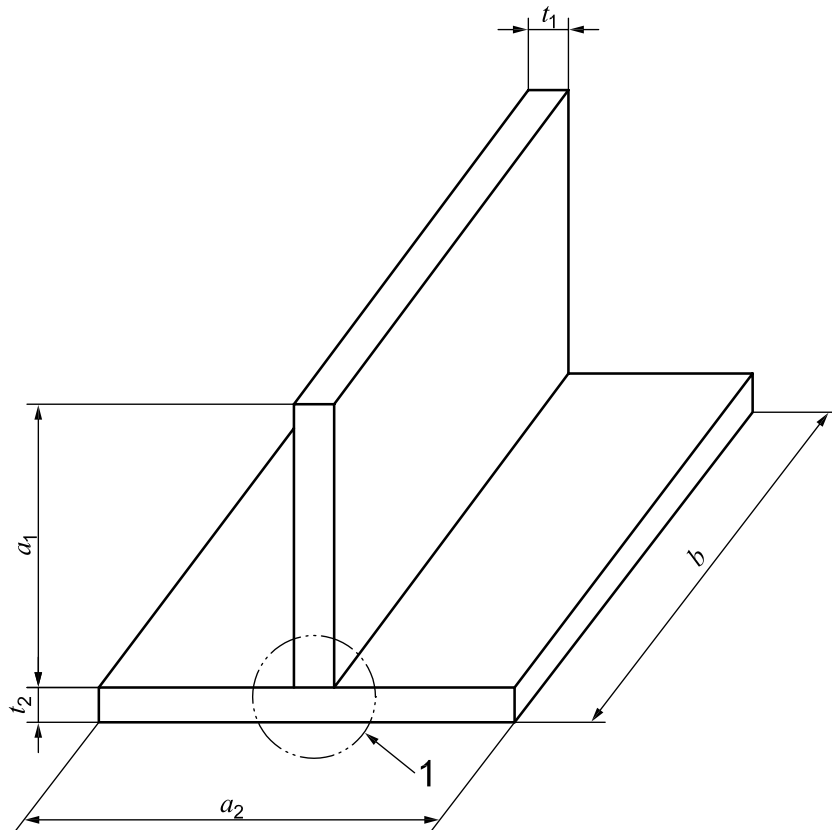

**Key**

- 1 joint preparation and fit-up as detailed in the pWPS
- $a_1, a_2$  minimum width 150 mm
- $b$  minimum length 350 mm
- $t_1$  material thickness, plate 1
- $t_2$  material thickness, plate 2

**Figure 4 — Test piece for a T-joint**

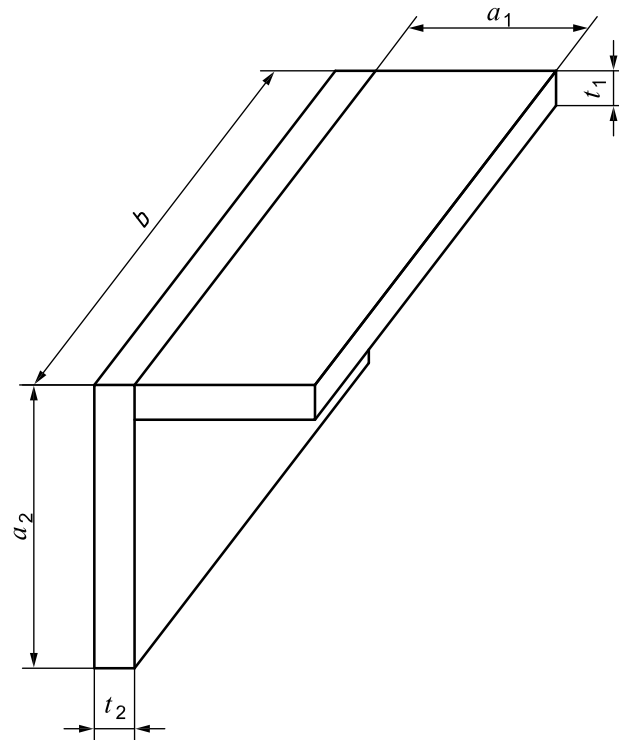

**Key**

- 1 joint preparation and fit-up as detailed in the pWPS
- $a_1, a_2$  minimum width 150 mm
- $b$  minimum length 350 mm
- $t_1$  material thickness, plate 1
- $t_2$  material thickness, plate 2

**Figure 5 — Test piece for a corner joint**

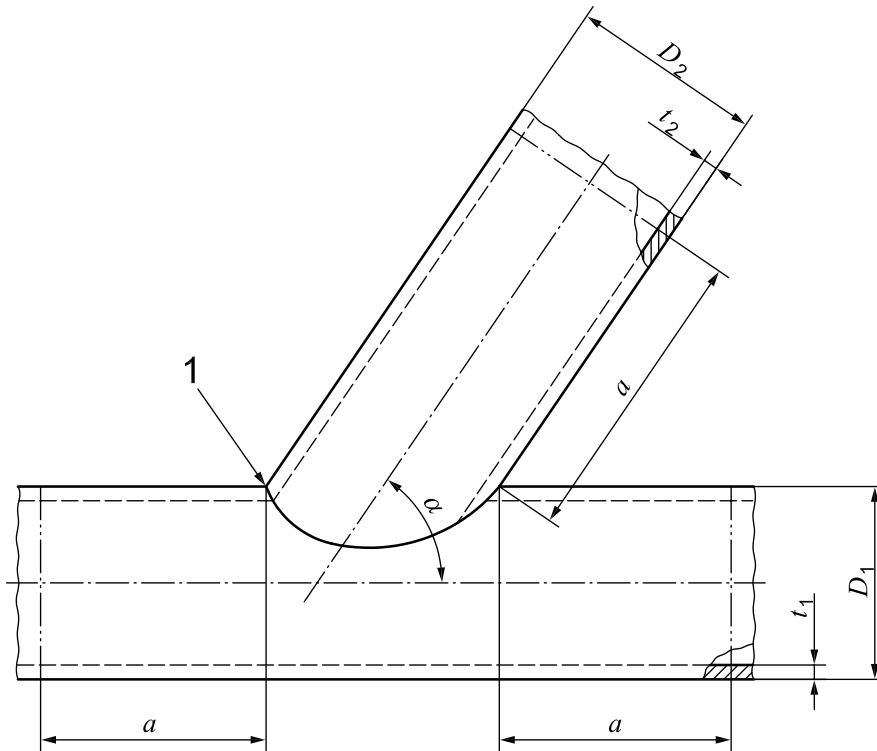

**Key**

- 1 joint preparation and fit-up as detailed in the pWPS
- $\alpha$  branch angle
- $a$  minimum length 150 mm
- $D_1$  outside diameter of the main pipe
- $D_2$  outside diameter of the branch pipe
- $t_1$  main pipe material thickness
- $t_2$  branch pipe material thickness

**Figure 6 — Test piece for a branch connection — Pipe to pipe**

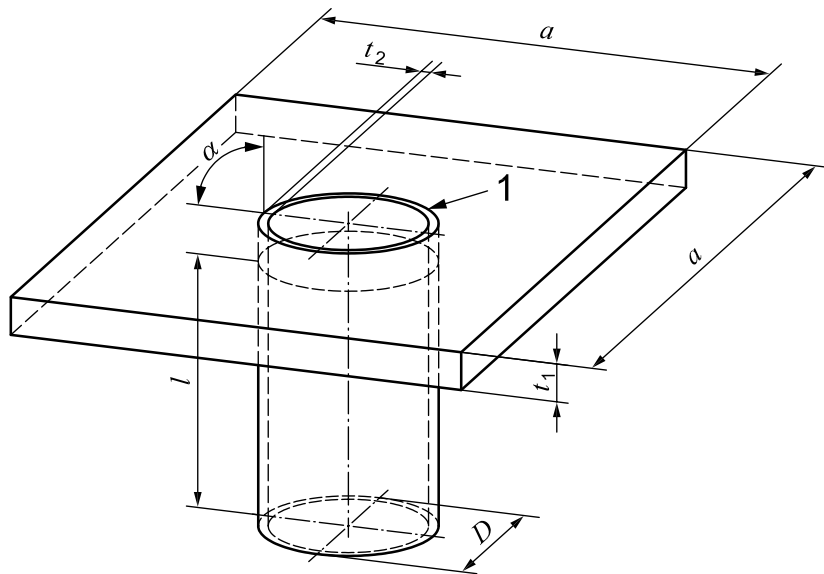

**Key**

- $\alpha$  branch angle
- 1 joint preparation and fit-up as detailed in the pWPS
- $a$  dimension of the plate;  $a \geq D + 6t_1$ ; minimum dimension  $D + 150$  mm
- $D$  outside diameter of the branch pipe
- $l$  branch pipe length; minimum length 80 mm
- $t_1$  plate material thickness
- $t_2$  branch pipe material thickness

**Figure 7 — Test piece for a branch connection — Pipe to plate**

## 7 Examination and testing

### 7.1 Extent of examination and testing

Testing includes both non-destructive testing and destructive testing which shall be in accordance with the requirements of [Table 1](#).

NOTE Specific service, material or manufacturing conditions can require more comprehensive testing than is specified by this part of ISO 15614 in order to gain more information and to avoid repeating the welding procedure test at a later date just to obtain additional test data.

An application standard may specify additional tests, e.g.:

- longitudinal weld tensile test;
- all weld metal bend test;
- corrosion tests;
- chemical analysis;
- microscopic examination;
- delta ferrite examination;
- cruciform test.

**Table 1 — Examination and testing of the test pieces**

Test piece	Type of test	Extent of testing
Butt joint with full penetration (see <a href="#">Figures 2</a> and <a href="#">3</a> )	Visual Radiographic or ultrasonica Surface crack detection <sup>b</sup> Transverse tensile test Transverse bend test <sup>c</sup> Impact test <sup>d</sup> Hardness test <sup>e</sup> Macroscopic examination <sup>f</sup>	100 % 100 % 100 % Two specimens Four specimens Two sets Required At least one specimen
T-joint and corner joint with full penetration (see <a href="#">Figures 4</a> and <a href="#">5</a> ) Branch connection with full penetration (see <a href="#">Figures 6</a> and <a href="#">7</a> )	Visual <sup>g</sup> Surface crack detection <sup>b,g</sup> Ultrasonic or radiographic <sup>a,g,h</sup> Hardness test <sup>e,g</sup> Macroscopic examination <sup>f,g</sup>	100 % 100 % 100 % Required At least two specimens
Butt joint, T-joint, corner joint and branch connection with partial penetration (see <a href="#">Figures 2</a> to <a href="#">7</a> )	Visual <sup>g</sup> Surface crack detection <sup>b,g</sup> Hardness test <sup>e,g</sup> Macroscopic examination <sup>g</sup>	100 % 100 % Required Two specimens
<p><sup>a</sup> Ultrasonic testing shall not be used for <math>t &lt; 8</math> mm and not for material groups 8, 10, 41 to 48. For information on material groups, see <a href="#">8.3.1</a>.</p> <p><sup>b</sup> Penetration testing or magnetic particle testing. For non-magnetic materials, penetration testing.</p> <p><sup>c</sup> For bend tests, see <a href="#">7.4.3</a>.</p> <p><sup>d</sup> One set in the weld metal and one set in the HAZ for materials <math>\geq 12</math> mm thick and having specified impact properties. Application standards may require impact testing below 12 mm thick. The testing temperature shall be chosen by the manufacturer with regard to the application or application standard, but need not be lower than the parent metal specification. For additional tests see <a href="#">7.4.5</a>.</p> <p><sup>e</sup> Not required for parent metals: subgroup 1.1, and groups 8, 41 to 48.</p> <p><sup>f</sup> One section is required for a butt weld in plate. Two sections are required for a butt weld in pipe, additionally one section from each overlap portion with different parameters. For each standard welding position in accordance with ISO 6947.</p> <p><sup>g</sup> Tests as detailed do not provide information on the mechanical properties of the joint. Where these properties are relevant to the application, an additional qualification shall also be held, e.g. a butt weld qualification.</p> <p><sup>h</sup> For outside diameter <math>\leq 50</math> mm no ultrasonic test is required. For outside diameter <math>&gt; 50</math> mm and where it is not technically possible to carry out ultrasonic examination, a radiographic examination shall be carried out provided the joint configuration allows meaningful results.</p>		

## 7.2 Location and taking of test specimens

Test specimens shall be taken in accordance with [Figures 8](#) to [13](#).

Test specimens shall be taken after all non-destructive testing (NDT) has been carried out and which has passed the relevant inspection criteria for the NDT method(s) used.

It is acceptable to take the test specimens from locations avoiding areas which have imperfections within the acceptance limits for the NDT method(s) used.

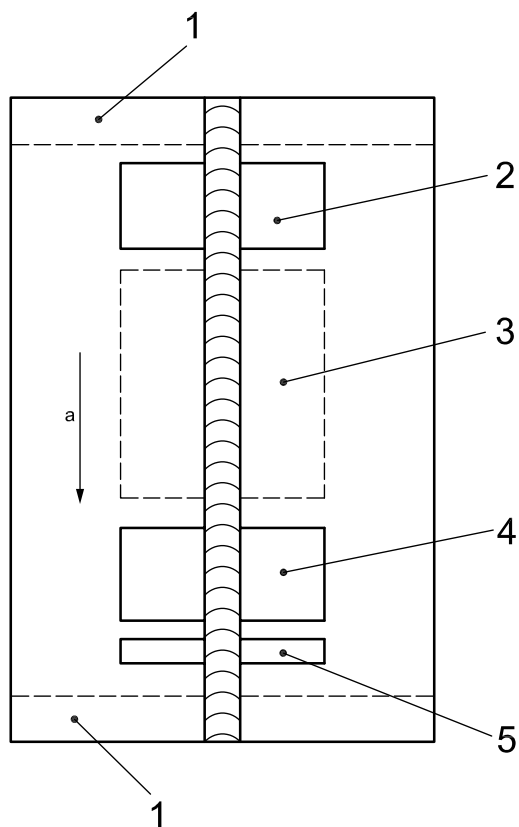

**Key**

- 1 discard 25 mm
- 2 area for:
  - one tensile test specimen;
  - bend test specimens
- 3 area for:
  - impact and additional test specimens if required
- 4 area for:
  - one tensile test specimen;
  - bend test specimens
- 5 area for:
  - one macroscopic examination;
  - one hardness test specimen
- a Welding direction.

NOTE Not to scale.

**Figure 8 — Location of test specimens for a butt joint in plate**



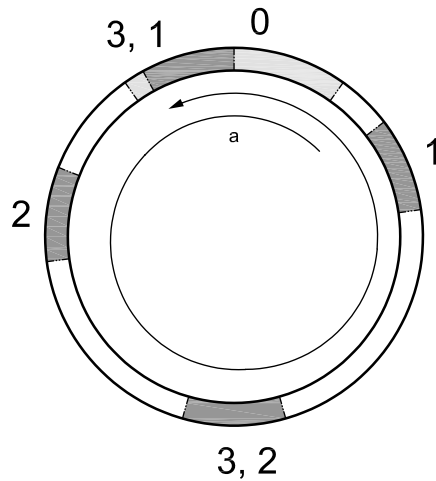

a) Uni-directional welding (orbital welding)

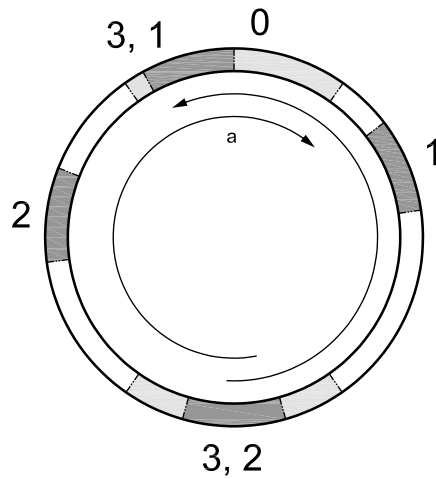

b) Bi-directional welding (semi-orbital welding)

**Key**

- 0 overlap zone (may be more than one)
- 1 area for:
  - one tensile test specimen;
  - bend test specimens
- 2 area for:
  - impact and additional test specimens if required
- 3 area for:
  - one macroscopic examination;
  - one hardness test specimen
- a Welding direction.

NOTE 1 If nominal energy per unit length (heat input) is constant (in case of rotating pipe, i.e. only one welding position), only one series of impact tests is required.

NOTE 2 Zones are not to scale and can be oriented differently from that shown.

**Figure 9 — Location of test specimens for butt joint in pipe**

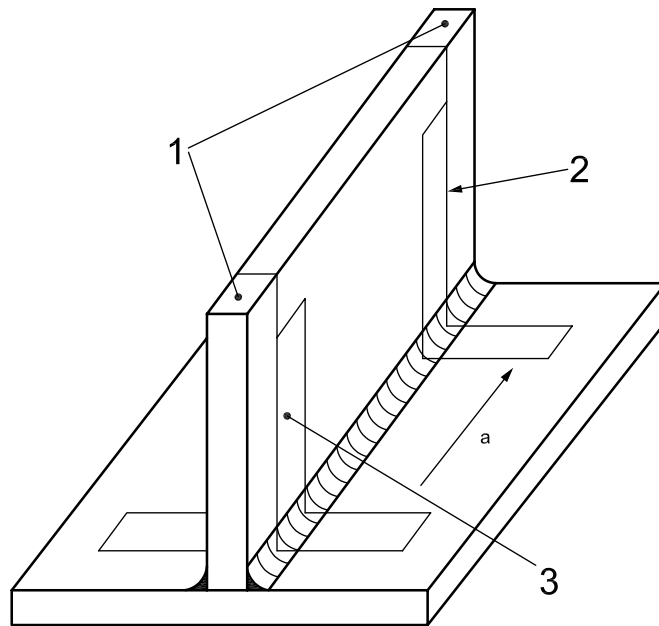

**Key**

- 1 discard 25 mm
- 2 macroscopic test specimen
- 3 macroscopic and hardness test specimen
- a Welding direction.

**Figure 10 — Location of test specimens in a T-joint**

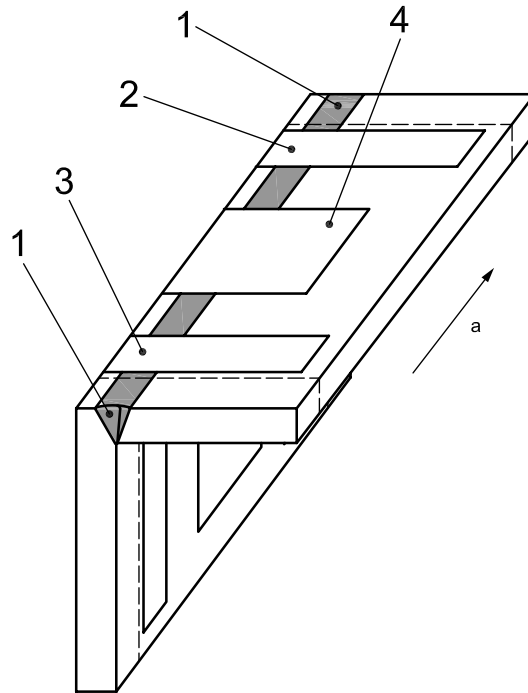

**Key**

- 1 discard 25 mm
- 2 macroscopic test specimen
- 3 macroscopic or hardness test specimen
- 4 other tests (if required)
- a Welding direction.

**Figure 11 — Location of test specimens in a corner joint**

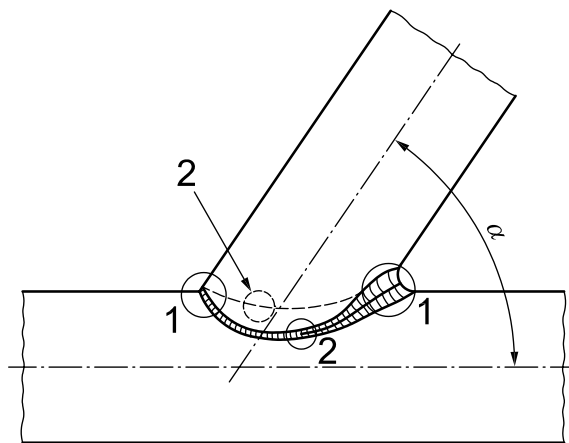

**Key**

- $\alpha$  branch angle
- 1 test specimen for macroscopic examination and hardness to be taken
- 2 test specimen for macroscopic examination to be taken from each overlap area

**Figure 12 — Location of test specimens in a pipe to pipe branch connection**

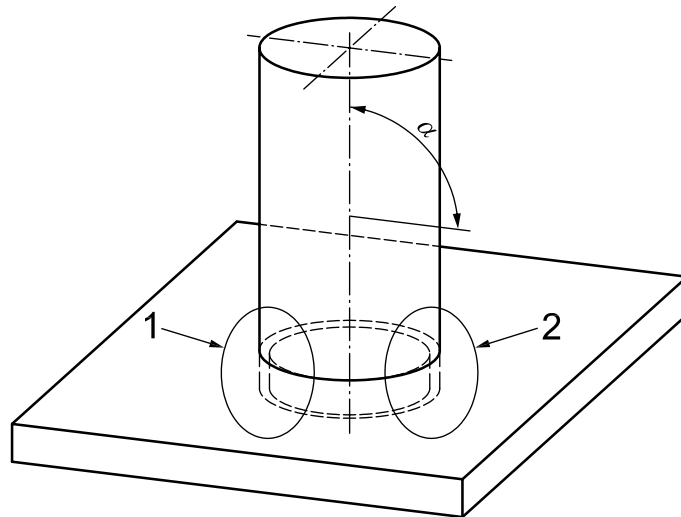

**Key**

- $\alpha$  branch angle
- 1 test specimen for macroscopic examination and hardness test specimen to be taken
- 2 test specimen for macroscopic examination to be taken from each overlap area

**Figure 13 — Location of test specimens in a pipe to plate branch connection**

**7.3 Non-destructive testing**

All non-destructive testing in accordance with 7.1 and Table 1 shall be carried out on the test pieces prior to cutting of the test specimens. Any post-weld heat treatment that is specified shall be completed prior to non-destructive testing.

For materials that are susceptible to hydrogen-induced cracking and where post-weld heat treatment or no post-weld heat treatment is specified, non-destructive testing shall be delayed in accordance with the application standard.

Depending upon joint geometry, materials, and the requirements for work, the non-destructive testing shall be carried out as required in Table 1 in accordance with ISO 17637 (visual examination), ISO 17636 (all parts) (radiographic testing), ISO 17640 (ultrasonic testing), ISO 3452-1 (penetration testing), and ISO 17638 (magnetic particle testing).

**7.4 Destructive testing**

**7.4.1 General**

The extent of testing shall be as required by Table 1.

**7.4.2 Transverse tensile test**

Specimens and testing for transverse tensile testing for butt joints shall be in accordance with ISO 4136.

For pipes >50 mm outside diameter, the excess weld metal shall be removed on both root and top faces to give the test specimen a thickness equal to the wall thickness of the pipe.

For pipes ≤50 mm outside diameter, and when full section small diameter pipes are used, the excess weld metal may be left undressed on the inside surface of the pipe.

The tensile strength of the test specimen shall not be less than the corresponding specified minimum value for the parent metal unless otherwise specified prior to testing.

For dissimilar parent metal joints, the tensile strength shall not be less than the minimum value specified for the parent material having the lowest tensile strength.

### 7.4.3 Bend test

Specimens and testing for bend testing for butt joints shall be in accordance with ISO 5173.

For thicknesses <12 mm, two root and two face bend test specimens shall be tested. For thicknesses ≥12 mm, four side bend specimens are recommended instead of root and face bend tests.

For dissimilar metal joints or heterogeneous butt joints in plates, one root and one face longitudinal bend test specimen may be used instead of four transverse bend tests.

The diameter of the former or the inner roller,  $d$ , shall be  $4t$  for parent metal with elongation  $A \geq 20\%$ . For parent metal with elongation  $A < 20\%$  the following equation shall be applied:

$$d = \frac{100 \times t_s}{A} - t_s$$

where

$t_s$  is the thickness of the bend test specimen;

$A$  is the minimum tensile elongation required by the material specification.

As a rule, the bend angle should be 180°, unless the strength or ductility of the parent metal or weld metal impose other limitations.

During testing, the test specimens shall not reveal any one single flaw >3 mm in any direction. Flaws appearing at the corners of a test specimen during testing shall be ignored in the evaluation.

### 7.4.4 Macroscopic examination

The test specimens shall be prepared and etched in accordance with ISO 17639 on one side to clearly reveal the fusion line, the HAZ, and the build-up of the runs.

The macroscopic examination shall include unaffected parent metal and shall be recorded by at least one macro-reproduction per procedure test.

The quality levels shall be in accordance with [7.5](#).

### 7.4.5 Impact testing

Test specimens and testing for impact tests shall be in accordance with this part of ISO 15614 for location of specimens and temperature of testing, and with ISO 9016 for dimensions and testing.

For weld metal, test specimen type VWT (V: Charpy V-notch - W: notch in weld metal - T: notch through the thickness) and for HAZ specimen type VHT (V: Charpy V-notch - H: notch in HAZ - T: notch through the thickness) shall be used. From each specified location, each set shall be comprised of three specimens.

Specimens with Charpy V-notch shall be used and sampled from a maximum of 2 mm below the surface of the parent metal and transverse to the weld.

In the HAZ, the notch shall be as close as possible to the fusion line, and in the weld metal the notch shall be at the weld centreline.

For thicknesses >20 mm, two additional sets of specimens shall be taken, one from the weld metal and one from the HAZ in the root area of the weld.

The impact energy shall be in accordance with the appropriate parent material standard, unless modified by the application standard. The average value of the three specimens shall meet the specified requirements. For each notch location, one individual value may be below the minimum average value specified, provided it is not less than 70 % of that value.

For dissimilar metal joints, impact tests shall be carried out on specimens from each HAZ in each parent metal.

Where multiple welding processes are qualified in a single test piece, impact test specimens shall be taken from the weld metal and HAZ that include each process.

**7.4.6 Hardness testing**

Vickers hardness testing shall be performed with a load matched to the weld geometry. Hardness values shall be determined for the weld metal, the HAZ and the parent metal. For material thicknesses ≤5 mm, only one row of indentations shall be made at a depth of <2 mm below the upper surface of the welded joint. For material thicknesses >5 mm, two rows of indentations shall be made at a depth of <2 mm below the upper and lower surfaces of the welded joint. For double sided welds, fillet and T-butt welds, one additional row of indentations shall be made through the root area. Examples of typical indentation patterns are shown in ISO 9015-1:2001, Figure 1, Figure 3, and Figure 4.

For each row, select at least three individual indentations in each of the following areas:

- the weld metal;
- both HAZs;
- both parent metals.

For the HAZ, the first indentation shall be placed as close to the fusion line as possible.

The results from the hardness test shall meet the requirements given in [Table 2](#). However requirements for Groups 6 (non post-weld heat treatment), 7, 10 and 11 and any dissimilar metal joints shall be specified prior to testing.

**Table 2 — Permitted maximum hardness values (HV 10)**

Steel groups ISO/ TR 15608	Non-post-weld heat treatment	Heat treated
1a, 2	380	320
3b	450	380
4, 5	380	320
6	—	350
9.1	350	300
9.2	450	350
9.3	450	350
<sup>a</sup> If hardness tests are required.		
<sup>b</sup> For steels with minimum $R_{eH} > 890$ N/mm <sup>2</sup> , special values shall be specified.		

**7.5 Quality levels**

A welding procedure is qualified if the imperfections in the test piece are within the limits of the specified quality level in accordance with ISO 12932. The test piece has also passed a procedure test in accordance with quality level B if the imperfections of excess weld metal, excessive convexity, excessive throat thickness, and excessive penetration comply with quality level C.

NOTE The correlation between the quality levels of ISO 12932 and the acceptance levels of the different NDT techniques is given in ISO 17635.<sup>[4]</sup>

## 7.6 Re-testing

If the test piece fails to comply with any of the requirements for visual examination or NDT specified in [7.5](#), one further test piece shall be welded and subjected to the same examination. If this additional test piece does not comply with the requirements, it has failed the welding procedure test.

If any test specimen fails to comply with the requirements for destructive testing in accordance with [7.4](#), but only due to weld imperfections, two further test specimens shall be tested for each one that failed. The additional test specimens can be taken from the same test piece if there is sufficient material or from a new test piece. Each additional test specimen shall be subjected to the same tests as the initial test specimen that failed. If either of the additional test specimens does not comply with the requirements, it has failed the welding procedure test.

If a tensile test specimen fails to meet the requirements of [7.4.2](#), two further test specimens shall be obtained for each one that failed. Both shall satisfy the requirements of [7.4.2](#).

For Charpy impact tests, where the results from a set of three specimens do not comply with the requirements, with only one lower value below 70 %, three additional specimens shall be taken. The average value of these three additional specimens and of the three initial specimens shall not be lower than the required value.

## 8 Range of qualification

### 8.1 General

Each of the conditions given in this clause shall be met in order to comply with this part of ISO 15614.

Changes outside the ranges specified shall require a new welding procedure test.

### 8.2 Related to the manufacturer

A qualification of a pWPS by a welding procedure test according to this part of ISO 15614 obtained by a manufacturer is valid for welding in workshops or sites under the same technical and quality control of the manufacturer.

Welding is under the same technical and quality control when the manufacturer who performed the welding procedure test retains complete responsibility for all welding carried out based on the pWPS.

### 8.3 Related to the parent material

#### 8.3.1 Parent material grouping

##### 8.3.1.1 General

In order to minimize the number of welding procedure tests, steels, nickel and nickel alloys are grouped in accordance with ISO/TR 15608.

Separate welding procedure qualifications are required for each parent material or parent material combinations not covered by the grouping system.

NOTE Minor compositional differences between similar grades arising from the use of national standards do not need requalification.

##### 8.3.1.2 Steels

The ranges of qualification are given in [Table 3](#).

8.3.1.3 Nickel alloys

The ranges of qualification are given in [Table 4](#).

8.3.1.4 Dissimilar joints between steels and nickel alloys

The ranges of qualification are given in [Table 4](#).

**Table 3 — Range of qualification for steel groups and subgroups**

Material (sub) group of test piece	Range of qualification
1 - 1	1 <sup>a</sup> - 1
2 - 2	2 <sup>a</sup> - 2, 1 - 1, 2 <sup>a</sup> - 1
3 - 3	3 <sup>a</sup> - 3, 1 - 1, 2 - 1, 2 - 2, 3 <sup>a</sup> - 1, 3 <sup>a</sup> - 2
4 - 4	4 <sup>b</sup> - 4, 4 <sup>b</sup> - 1, 4 <sup>b</sup> - 2
5 - 5	5 <sup>b</sup> - 5, 5 <sup>b</sup> - 1, 5 <sup>b</sup> - 2
6 - 6	6 <sup>b</sup> - 6, 6 <sup>b</sup> - 1, 6 <sup>b</sup> - 2
7 - 7	7 <sup>c</sup> - 7
7 - 3	7 <sup>c</sup> - 3, 7 <sup>c</sup> - 1, 7 <sup>c</sup> - 2
7 - 2	7 <sup>c</sup> - 2 <sup>a</sup> , 7 <sup>c</sup> - 1
8 - 8	8 <sup>c</sup> - 8
8 - 6	8 <sup>c</sup> - 6 <sup>b</sup> , 8 <sup>c</sup> - 1, 8 <sup>c</sup> - 2, 8 <sup>c</sup> - 4
8 - 5	8 <sup>c</sup> - 5 <sup>b</sup> , 8 <sup>c</sup> - 1, 8 <sup>c</sup> - 2, 8 <sup>c</sup> - 4, 8 <sup>c</sup> - 6.1, 8 <sup>c</sup> - 6.2
8 - 3	8 <sup>c</sup> - 3 <sup>a</sup> , 8 <sup>c</sup> - 1, 8 <sup>c</sup> - 2
8 - 2	8 <sup>c</sup> - 2 <sup>a</sup> , 8 <sup>c</sup> - 1
9 - 9	9 <sup>b</sup> - 9
10 - 10	10 <sup>b</sup> - 10
10 - 8	10 <sup>b</sup> - 8 <sup>c</sup>
10 - 6	10 <sup>b</sup> - 6 <sup>b</sup> , 10 <sup>b</sup> - 1, 10 <sup>b</sup> - 2, 10 <sup>b</sup> - 4
10 - 5	10 <sup>b</sup> - 5 <sup>b</sup> , 10 <sup>b</sup> - 1, 10 <sup>b</sup> - 2, 10 <sup>b</sup> - 4, 10 <sup>b</sup> - 6.1, 10 <sup>b</sup> - 6.2
10 - 3	10 <sup>b</sup> - 3 <sup>a</sup> , 10 <sup>b</sup> - 1, 10 <sup>b</sup> - 2
10 - 2	10 <sup>b</sup> - 2 <sup>a</sup> , 10 <sup>b</sup> - 1
11 - 11	11 <sup>b</sup> - 11, 11 <sup>b</sup> - 1
<sup>a</sup> Covers steels of equal or lower specified yield strengths in the same group. <sup>b</sup> Covers steels in the same subgroup and any lower subgroup within the same group. <sup>c</sup> Covers steels in the same subgroup.	



**Table 4 — Range of qualification for nickel alloy and nickel alloy/steel groups**

Material group of the test pieces	Range of qualification
41 – 41	41 <sup>a</sup> – 41
42 – 42	42 <sup>a</sup> – 42
43 – 43	43 <sup>a</sup> – 43, 45 <sup>a</sup> – 45, 47 <sup>a</sup> – 47
44 – 44	44 <sup>a</sup> – 44
45 – 45	45 <sup>a</sup> – 45, 43 <sup>a</sup> – 43 <sup>a</sup>
46 – 46	46 <sup>a</sup> – 46
47 – 47	47 <sup>a</sup> – 47, 43 <sup>a</sup> – 43 <sup>a</sup> , 45 <sup>a</sup> – 45 <sup>a</sup>
48 – 48	48 <sup>a</sup> – 48
41 to 48 – 2	41 to 48 <sup>a</sup> – 2 <sup>b</sup> , 41 to 48 <sup>a</sup> – 1
41 to 48 – 3	41 to 48 <sup>a</sup> – 3 <sup>b</sup> , 41 to 48 <sup>a</sup> – 2 or 1
41 to 48 – 5	41 to 48 <sup>a</sup> – 5 <sup>c</sup> , 41 to 48 <sup>a</sup> – 6.2 or 6.1 or 4 or 2 or 1
41 to 48 – 6	41 to 48 <sup>c</sup> – 6 <sup>c</sup> , 41 to 48 <sup>a</sup> – 4 or 2 or 1
<p>NOTE For groups 41 to 48, a procedure test carried out with a precipitation-hardenable alloy in a group covers all precipitation-hardenable alloys in that group welded to all solid solution alloys in the same group.</p> <p>a For groups 41 to 48, a procedure test carried out with a solid solution or precipitation hardenable alloy in a group covers all solid solution or precipitation hardenable alloys respectively in the same group.</p> <p>b Covers steels of equal or lower specified yield strengths in the same group.</p> <p>c Covers steels in the same subgroup and any lower subgroup within the same group.</p>	

When impact testing is required, the welding procedure is qualified only for the service temperature at or above the test temperature. If lower service temperature is required, the impact testing shall be performed at the lower temperature.

### 8.3.2 Material thickness and pipe diameter

#### 8.3.2.1 General

For single process qualification,  $t$  is the thickness of the respective test piece.

For multi-process qualification, the recorded thickness contribution of each process shall be used as a basis for the range of qualification for the individual welding process.

**8.3.2.2 Range of qualification for butt joints, T-joints, corner joints as well as branch connections**

- a) Butt joint with complete and partial penetration (single-side and both-sides welded) (applies to plates and pipes).

Thickness of test piece	Range of qualification
$t < 5 \text{ mm}$	$t$
$t \geq 5 \text{ mm}$	$0,8t \text{ to } t$

Combinations of different plate thicknesses shall be qualified separately and the qualification applies only to that combination.

- b) T-joint with complete and partial penetration (single-side and both-sides welded, applies also to pipe-plate connections)

The range of qualification relates to the thickness of the web plate  $t_1$  (see [Figure 4](#)).

Thickness of test piece	Range of qualification
$t_1 < 5 \text{ mm}$	$t_1$
$t_1 \geq 5 \text{ mm}$	$0,8t_1 \text{ to } t_1$

When  $t_1 > t_2$ , each combination shall be qualified separately and the qualification applies only to that combination.

- c) Corner joint with complete and partial penetration (single-side and both-sides welded)

The range of qualification relates to the thickness of the fitted plate  $t_1$  (see [Figure 5](#)).

Thickness of test piece	Range of qualification
$t_1 < 5 \text{ mm}$	$t_1$
$t_1 \geq 5 \text{ mm}$	$0,8t_1 \text{ to } t_1$

When  $t_1 > t_2$ , each combination shall be qualified separately and the qualification applies only to that combination.

**8.3.2.3 Range of qualification for the diameter of pipes and branch connections**

The qualification of a welding procedure test on diameter,  $D$ , shall include qualification for diameters in the following ranges given in [Table 5](#).

Qualification given for plates also covers pipes when the outside diameter is  $>500 \text{ mm}$  or when the diameter is  $>150 \text{ mm}$  welded in the PA or PC rotated position according to ISO 6947.

**Table 5 — Range of qualification for pipe and branch connection diameters**

Diameter of the test piece <sup>a</sup> $D$ mm	Range of qualification
$D \leq 25$	$0,5D \text{ to } 2D$
$D > 25$	$\geq 0,5D \text{ (25 mm min.)}$
NOTE For structural hollow section, $D$ is the dimension of the smaller side.	
<sup>a</sup> The outside diameter of the pipe or outside diameter of the branch pipe.	

### 8.3.3 Angle of branch connection

A welding procedure test carried out on a branch connection with angle  $\alpha$  shall qualify all branch angles  $\alpha_1$  in the range  $\alpha \leq \alpha_1 \leq 90^\circ$ .

### 8.4 Related to welding process

Each degree of mechanization shall be qualified independently (fully mechanized and automatic).

The qualification of laser-arc hybrid welding in combination with other arc processes shall be performed by a multi-process procedure test.

It is not allowed to use a multi-process procedure test to qualify any single process unless the testing carried out on the process conforms to this part of ISO 15614.

### 8.5 Related to welding position

Welding of a test in any one welding position qualifies only this welding position.

### 8.6 Related to type of joint or weld

Welding of a test for any one type of joint or weld qualifies only this type of joint or weld.

### 8.7 Related to number of layers

The qualified WPS is effective only insofar as the number of layers is the same as that used in the procedure test.

### 8.8 Related to filler material

Filler materials cover other filler materials as long as they have equivalent mechanical properties, same type of covering, core or flux, same nominal composition, and the same or lower hydrogen content in accordance with the designation in the appropriate International Standard for the filler material concerned.

It is not permitted to change the diameter of the filler material.

### 8.9 Related to type of current

The qualification is given for the type of current [alternating current (AC), direct current (DC), pulsed current] and polarity used in the welding procedure test.

### 8.10 Related to preheating and interpass temperature

When preheating is required, the lower limit of qualification is the nominal preheating temperature applied at the start of the welding procedure test.

The upper limit of the qualification is the highest interpass temperature reached in the welding procedure test.

### 8.11 Related to post-weld heat treatment

A change in the initial heat treatment condition prior to welding of precipitation hardenable materials is not permitted.

Addition or deletion of post-weld heat treatment is not permitted.

The temperature range validated is the holding temperature  $\pm 20$  K used in the welding procedure test, unless otherwise specified. Where required, heating rates, cooling rates, and holding time shall be related to the product.

The temperature and duration of post-heating for hydrogen release shall not be reduced. Post-heating shall not be omitted, but may be added.

### 8.12 Nominal heat input

The upper limit of nominal heat input qualified is 15 % greater than that used in welding the test piece. The lower limit of nominal heat input qualified is 15 % lower than that used in welding the test piece.

Nominal heat input,  $Q_{\text{nom}}$ , is calculated as follows:

$$Q_{\text{nom}} = \frac{(P + U \times I)}{v} 10^{-3}$$

where

$Q_{\text{nom}}$  is the nominal heat input, in kilojoule per millimetre;

$P$  is the laser power, in kilowatt;

$U$  is the arc voltage, measured as near as possible to the arc, in volt;

$I$  is the welding current, in ampere;

$v$  is the travel speed, in millimetres per second.

If welding procedure tests have been performed at both a high and a low heat input level, then all intermediate heat inputs are also qualified.

### 8.13 Duration of validity

The duration of validity of the welding procedure qualification is unlimited provided no major modification of the welding machine has been made that changes laser beam characteristics or arc characteristics.

## 9 Welding procedure qualification record (WPQR)

The welding procedure qualification record (WPQR) is a statement of the results of assessing each test piece including re-tests. The relevant items listed for the WPS in ISO 15609-6 shall be included, together with details of any features that would be rejectable by the requirements of [Clause 7](#). If no rejectable features or unacceptable test results are found, a WPQR detailing the welding procedure test piece results is qualified and shall be signed and dated by the examiner or the examining body.

A WPQR template shall be used to record details for the welding procedure and the test results, in order to facilitate uniform presentation and assessment of the data.

An example of a WPQR template is shown in [Annex A](#). The user of this form is allowed to copy this (present) form.

## Annex A (informative)

### Welding procedure qualification record template (WPQR)

#### Test results

Manufacturer's WPQR-No.:

Examiner or examining body:

Visual:

Reference No.:

Penetrant/Magnetic particle\*:

Radiography\*:

Ultrasonic\*:

Tensile Tests

Temperature:

Type/No.	Yield strength, $R_e$ MPa	Tensile strength, $R_m$ MPa	Elongation after fracture, $A$ %	Reduction in area, $Z$ %	Fracture Location	Remarks
Requirement						

Bend Tests

Former Diameter:

Type/No.	Bend angle	Elongation*	Results

Macroscopic Examination:

Impact test\*

Type:

Size:

Requirement:

Notch location/ direction	Temperature °C	Values			Average	Remarks
		1	2	3		

Hardness test\* (Type/Load)

Location of measurements (Sketch\*)

Parent Metal:

HAZ:

Weld metal:

Other tests:

Remarks:

Tests carried out in accordance with the requirements of:

Laboratory Report Reference No.:

Test results were acceptable/not acceptable (delete as appropriate)

Tests carried out in presence of:

\* If required.

.....  
Examiner or examining body

Name, date and signature

## Bibliography

- [1] ISO 17635, *Non-destructive testing of welds — General rules for metallic materials*
- [2] ISO 9015-1:2001, *Destructive tests on welds in metallic materials — Hardness testing — Part 1: Hardness test on arc welded joints*



---

---

**ICS 25.160.10**

Price based on 24 pages