

INTERNATIONAL STANDARD

ISO 15541

First edition
1999-08-01

Ships and marine technology — Fire resistance of hose assemblies — Requirements for the test bench

*Navires et technologie marine — Résistance au feu des tuyauteries —
Exigences du banc d'essai*



Reference number
ISO 15541:1999(E)

Foreword

ISO (the International Organization for Standardization) is a worldwide federation of national standards bodies (ISO member bodies). The work of preparing International Standards is normally carried out through ISO technical committees. Each member body interested in a subject for which a technical committee has been established has the right to be represented on that committee. International organizations, governmental and non-governmental, in liaison with ISO, also take part in the work. ISO collaborates closely with the International Electrotechnical Commission (IEC) on all matters of electrotechnical standardization.

International Standards are drafted in accordance with the rules given in the ISO/IEC Directives, Part 3.

Draft International Standards adopted by the technical committees are circulated to the member bodies for voting. Publication as an International Standard requires approval by at least 75 % of the member bodies casting a vote.

International Standard ISO 15541 was prepared by Technical Committee ISO/TC 8, *Ships and marine technology*, Subcommittee SC 3, *Piping and machinery*.

© ISO 1999

All rights reserved. Unless otherwise specified, no part of this publication may be reproduced or utilized in any form or by any means, electronic or mechanical, including photocopying and microfilm, without permission in writing from the publisher.

International Organization for Standardization
Case postale 56 • CH-1211 Genève 20 • Switzerland
Internet iso@iso.ch

Printed in Switzerland

Introduction

The main objective of the test using the test bench described in this International Standard is to determine whether and for how long a hose assembly can be exposed to fire, without becoming inoperable, e.g. without becoming untight when subjected to the envisaged working pressure. Despite the fact that the attacking fire is simulated so as to correspond to a fire occurring in practice, it cannot be assumed that the duration of resistance to fire as recorded during the test will also occur in the event of an actual fire, as the conditions of installation, which essentially affect the duration of resistance to fire, may vary from case to case.

Tests carried out using the test bench specified in this International Standard are intended to lead to results capable of being reproduced.

Ships and marine technology — Fire resistance of hose assemblies — Requirements for the test bench

1 Scope

This International Standard specifies requirements for a test bench to determine the fire resistance of hose assemblies, in particular by tests according to ISO 15540, up to at least 100 mm nominal diameter. During the exposure to flames, there are possible working pressures up to 10 bar.

The flame spread ability of the hose cannot be tested with the test bench specified in this International Standard.

Only water is permitted as a test medium. With a view to ensuring maximum safety for both the operating personnel and the test bed in the event of damage to the hose during the test, the use of combustible test media is excluded.

2 Normative reference(s)

The following normative documents contain provisions that, through reference in this text, constitute provisions of this International Standard. For dated references, subsequent amendments to, or revisions of, any of these publications do not apply. However, parties to agreements based on this International Standard are encouraged to investigate the possibility of applying the most recent editions of the normative documents indicated below. For undated references, the latest edition of the normative document referred to applies. Members of ISO and IEC maintain registers of currently valid International Standards.

ISO 15540:1999, *Ships and marine technology — Fire resistance of hose assemblies — Test methods*.

IEC 60051-1:1984, *Direct acting indicating, analogue electrical-measuring instruments and their accessories — Part 1: Definitions and general requirements common to all parts*.

IEC 60051-1, *Amendment No. 1:1994*.

IEC 60051-1, *Amendment No. 2:1995*.

3 Term and definition

For the purposes of this International Standard, the following term and definition applies.

3.1

fire resistance

ability of an element of building construction, component or structure, to fulfil for a stated period of time the required stability, integrity, thermal insulation and/or other expected duty specified, in a standard fire resistance test

4 Requirements

4.1 Components of test bench

The test bench shall consist of the following parts (see Figure 1):

- burner chamber with connecting device for the hose assembly, burner and exhaust gas trunk (see 4.2);
- aggregate box with equipment for conditioning and controlling the test medium (see 4.3);
- equipment for monitoring and recording the test procedure (see 4.4);
- pressure-producing equipment which can load the test piece at the end of flame application with a test pressure as specified in the technical specification (see 4.5).

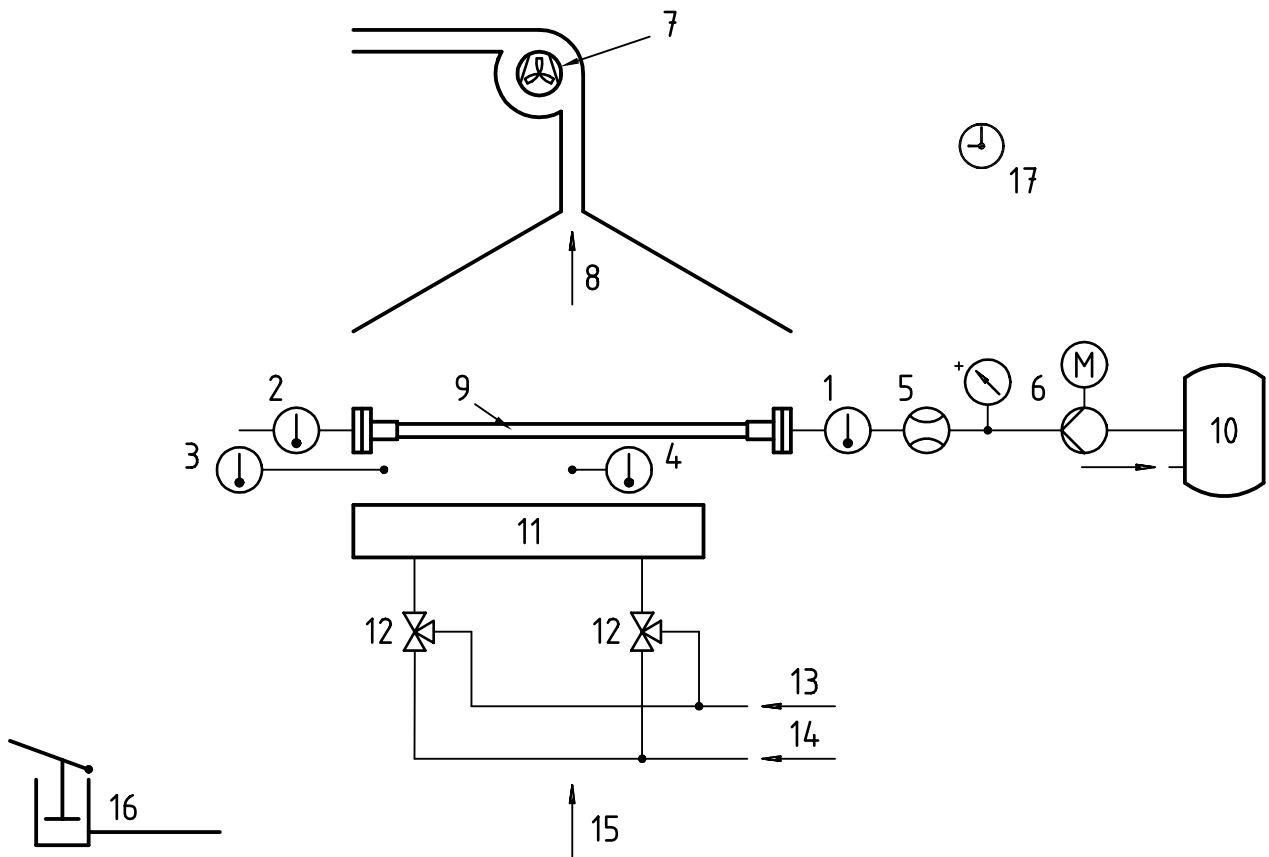

Key

Indication, measurement, recording, control and adjustments

- | | | | |
|---|--|----|--------------------------------|
| 1 | Water temperature at test piece, inlet | 7 | Fan |
| 2 | Water temperature at test piece, outlet | 8 | Exhaust gas |
| 3 | Flame temperature below centre of test piece | 9 | Test piece |
| 4 | Flame temperature below test piece outlet | 10 | Watertank with heating/cooling |
| 5 | Flow rate of water | 11 | Sectional area burner |
| 6 | Working pressure during test | 12 | Mixing valve |
| | | 13 | Gas |
| | | 14 | Combustion gas |
| | | 15 | Air supply |
| | | 16 | Pump for pressure test |
| | | 17 | Test duration |

Figure 1 — Diagram of test bench

4.2 Burner chamber

4.2.1 General

The connections of the test piece shall be arranged to an operation height (e.g. 1 100 mm). They shall enable testing of hose assemblies with a free length of hose of 500 mm minimum. A steady air flow upwards shall be provided. The base area of the air supply shall be approximately 0,6 m².

An example of an arrangement of a burner chamber, is shown in Figure 2.

4.2.2 Burner

The total sectional area of the burner shall be 150 mm × 500 mm minimum. The sectional area can consist of several single-area burner units.

Burners with a minimum of 20 nozzles per square decimetre shall be used.

Burners shall be of the fan type.

Each single-area burner unit shall be provided with a mixing valve for mixing the gases and the combustion air, creating a neutral flame of (800 ± 50) °C below the hose assembly on test.

The burner shall be movable to avoid exposing the test piece to the flames during adjustment of the flame.

The burner shall be variable in height in order that the flame can envelop test pieces of all possible nominal diameters. Temperatures measured, approximately 15 mm directly under the test piece, shall be (800 ± 50) °C.

4.2.3 Exhaust trunk

The exhaust gas shall be drawn off upwards by means of an exhaust fan. The fan shall be infinitely variable. The upward air flow shall produce a directed flame.

Environmental restrictions according to local law shall be taken into consideration.

4.2.4 Coolant circuit

For controlling the coolant circuit, shut-off valves and measuring instruments shall be provided in the coolant supply and drain line.

4.3 Aggregate box

Heating and cooling arrangements shall be provided for supplying the test piece with water of (80 ± 2) °C at the test piece inlet.

The velocity of flow of the test medium in the test piece shall be adjustable to 0,1 m/s.

The installation shall provide for an adjustable working pressure up to 10 bar during the fire test, with the test piece fitted.

4.4 Monitoring and recording

4.4.1 Control and adjustments

The parameters listed in Figure 1 and Table 1 shall be controllable/adjustable in the given range by means of suitable measurements.

Dimensions in millimetres

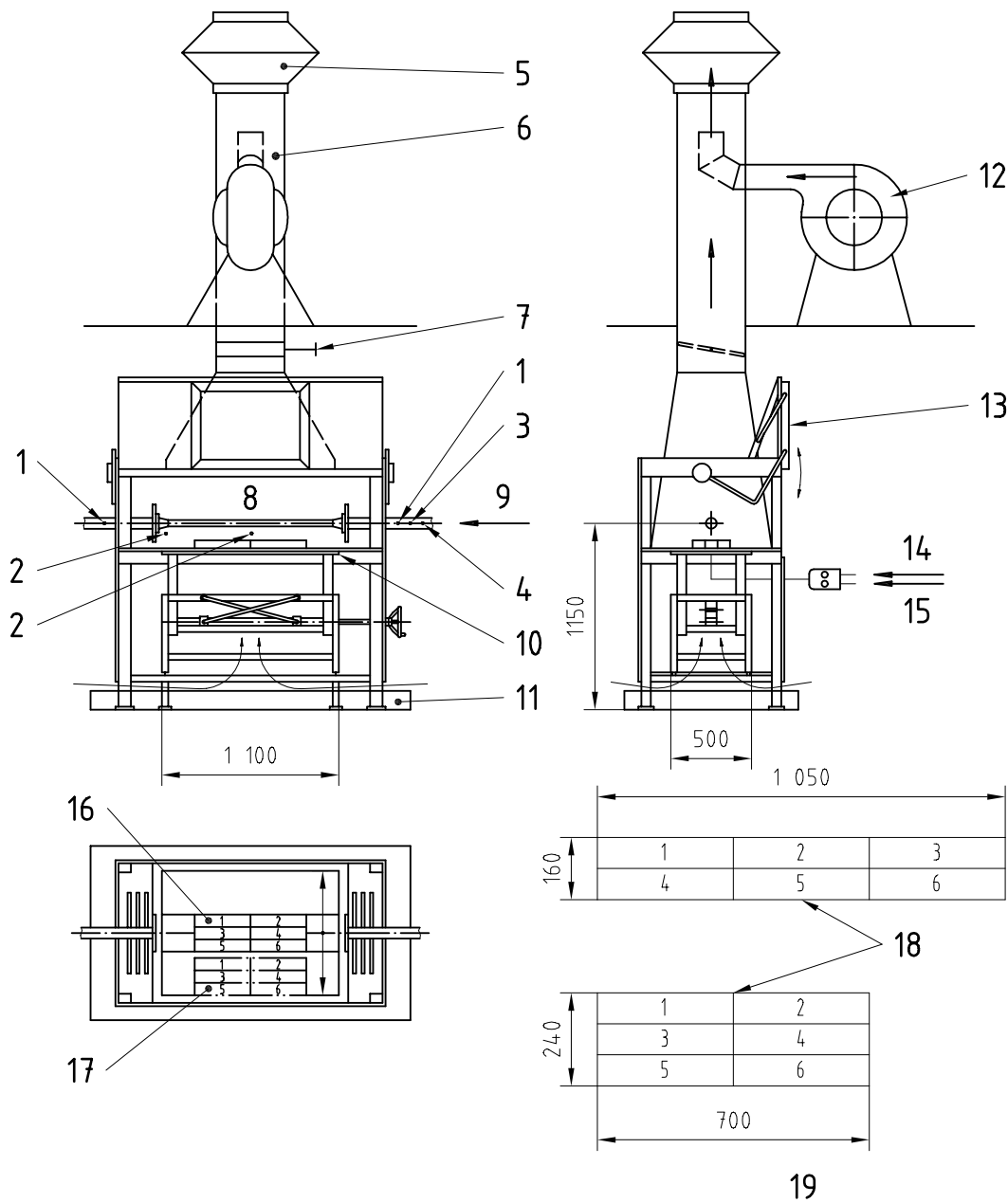

- Key**
- | | | | |
|----|---------------------------|----|---|
| 1 | Water temperatures | 11 | Drip tray for water, respectively residues of combustion |
| 2 | Flame temperatures | 12 | Exhaust fan |
| 3 | Flow rate | 13 | View window |
| 4 | Working pressure of water | 14 | Propane |
| 5 | Diffuser | 15 | Combustion air |
| 6 | Exhaust trunk | 16 | Working position of burner sectional area |
| 7 | Throttle valve | 17 | Normal position of burner sectional area for adjustment of flame |
| 8 | Test specimen | 18 | Burner arrangements |
| 9 | Water | 19 | Example: six single burner units forming two different burner sectional areas |
| 10 | Burner-support | | |

Figure 2 — Example of a burner chamber

Table 1 — Parameter control and adjustment ranges

Number according to Figure 1	Parameter	Range	Remarks
1 and 2	Water temperature	up to 85 °C max. deviation: ± 2 °C	—
3 and 4	Flame temperature	(800 ± 50) °C	Temperature 15 mm to 20 mm below test piece.
5	Flow rate of water	—	Velocity of flow 0,1 m/s with flow rates > 0 l/min. The velocity of flow shall be adequate for the requirements in respect of the temperature of the test medium.
6	Working pressure of water	up to 10 bar max. deviation: $\pm 0,1$ bar	Working pressure eligible; max. deviation is valid for the specified pressure.
17	Test duration	max. 9 999 s	Stop at end of test or interruption.

4.4.2 Measurements, recording and indication

Test parameters shall be measured, recorded and indicated at least once within 2 min as detailed in Table 2.

Table 2 — Parameter-recording requirements

Number according to Figure 1	Parameter	Measurement, indication and recording
1	Water temperature at test piece, inlet	X
2	Water temperature at test piece, outlet	X
3	Flame temperature below centre of test piece	X
4	Flame temperature below test piece outlet	X
5	Volume flow rate of water	X
6	Working pressure during test	X
17	Test duration	X

NOTE Additional warning lights may be provided for exceeding or falling below permissible temperatures, pressures, etc.

The instruments shall correspond to the following precision classes, or have the following tolerances:

Pressure gauges: $\pm 1,0$ % of max. scale value

Electrical measuring instruments: Class 1 according to IEC 60051-1

Non-electrical measuring instruments: $\pm 1,0$ % of max. scale value

Flow meter: $\pm 1,0$ % of max. scale value

The survey of the testing equipment shall be carried out according to a recognized quality control system, for example, based on International Standards from the ISO 9000 series (see the bibliography).

4.4.3 Safety facilities

4.4.3.1 Requirements

The following requirements apply to the test bench setup:

- a) The gas supply to the burner shall be protected by a thermo-electrical ignition safety feature. The gas supply to the burner shall automatically be switched off when
 - the flame goes out by itself,
 - the pressure drops in the test piece,
 - the test box is opened,
 - the gas exhaust is insufficient, and
 - an emergency stop occurs;
- b) In the case of switching off for safety reasons, quick-closing valves shall cut off at the test piece inlet and outlet. The circuit shall be pressure released.
- c) In case the test piece is destroyed, the evacuation of leakage water from the burner shall be ensured.
- d) The working pressure in the water circuit shall be limited to 12 bar by a safety valve.
- e) It shall be ensured that the heating for warming up the water can only be switched on when the circulation pump is working. Additionally, a thermostatic limitation of the maximum admissible temperature in the boiler shall be provided.

4.4.3.2 Tests

The conditions specified in 4.4.3.1 a) for a switch-off of the gas supply shall be set. The gas supply shall be disconnected.

After switching off according to 4.4.3.1 a), proof shall be established that the requirements according to 4.4.3.1 b) are met.

The burner shall be flooded once, while the gas supply is switched off. Proof shall be established that the water is evacuated as required by 4.4.3.1 c).

Proof shall be established that the working pressure safety valve limits the working pressure in the system to 12 bar as required by 4.4.3.1 d).

Proof shall be established that it is not possible to switch on the heating while the circulation pump is switched off, as described in 4.4.3.1 e). Additionally, proof shall also be established that the water temperature in the boiler does not exceed the maximum admissible temperature.

4.5 Pressure-producing equipment

Pressure-producing equipment shall be provided, which can load the test piece with an internal working pressure up to its test pressure according to standard or other specification at the end of the flame application.

This pressure-producing equipment can be arranged outside the actual test bench.

Annex A (informative)

Bibliography

- [1] ISO 2768-1:1989, *General tolerances — Part 1: Tolerances for linear and angular dimensions without individual tolerance indications.*
- [2] ISO 9000-1:1994, *Quality management and quality assurance standards — Part 1: Guidelines for selection and use.*
- [3] ISO 9000-2:1997, *Quality management and quality assurance standards — Part 2: Generic guidelines for the application of ISO 9001, ISO 9002 and ISO 9003.*
- [4] ISO 9000-3:1997, *Quality management and quality assurance standards — Part 3: Guidelines for the application of ISO 9001:1994 to the development, supply, installation and maintenance of computer software.*
- [5] ISO 9000-4:1993, *Quality management and quality assurance standards — Part 4: Guide to dependability programme management Bilingual edition.*
- [6] ISO 9001:1994, *Quality systems — Model for quality assurance in design, development, production, installation and servicing.*
- [7] ISO 9002:1994, *Quality systems — Model for quality assurance in production, installation and servicing.*
- [8] ISO 9003:1994, *Quality systems — Model for quality assurance in final inspection and test.*
- [9] ISO 9004-1:1994, *Quality management and quality system elements — Part 1: Guidelines.*
- [10] ISO 9004-2:1991, *Quality management and quality system elements — Part 2: Guidelines for services.*
- [11] ISO 9004-3:1993, *Quality management and quality system elements — Part 3: Guidelines for processed materials.*
- [12] ISO 9004-4:1993, *Quality management and quality system elements — Part 4: Guidelines for quality improvement.*

www.iso.org

ICS 47.020.30; 83.140.40

Price based on 7 pages
