

---

---

**Specification for diagrams for process  
industry —**

**Part 1:  
General rules**

*Spécifications pour schémas de l'industrie de traitement —  
Partie 1: Règles générales*



Reference number  
ISO 15519-1:2010(E)

© ISO 2010

**PDF disclaimer**

This PDF file may contain embedded typefaces. In accordance with Adobe's licensing policy, this file may be printed or viewed but shall not be edited unless the typefaces which are embedded are licensed to and installed on the computer performing the editing. In downloading this file, parties accept therein the responsibility of not infringing Adobe's licensing policy. The ISO Central Secretariat accepts no liability in this area.

Adobe is a trademark of Adobe Systems Incorporated.

Details of the software products used to create this PDF file can be found in the General Info relative to the file; the PDF-creation parameters were optimized for printing. Every care has been taken to ensure that the file is suitable for use by ISO member bodies. In the unlikely event that a problem relating to it is found, please inform the Central Secretariat at the address given below.



**COPYRIGHT PROTECTED DOCUMENT**

© ISO 2010

All rights reserved. Unless otherwise specified, no part of this publication may be reproduced or utilized in any form or by any means, electronic or mechanical, including photocopying and microfilm, without permission in writing from either ISO at the address below or ISO's member body in the country of the requester.

ISO copyright office  
Case postale 56 • CH-1211 Geneva 20  
Tel. + 41 22 749 01 11  
Fax + 41 22 749 09 47  
E-mail [copyright@iso.org](mailto:copyright@iso.org)  
Web [www.iso.org](http://www.iso.org)

Published in Switzerland

# Contents

Page

Foreword .....	v
Introduction.....	vi
1 Scope .....	1
2 Normative references .....	1
3 Terms and definitions .....	2
3.1 Basic terms .....	2
3.2 Document types.....	3
3.3 Reference designation .....	4
4 Documentation principles .....	5
4.1 General .....	5
4.2 Technical product documentation.....	5
4.3 Representation aspects .....	6
4.4 Focus area in this part of ISO 15519 .....	7
5 Document sheets.....	7
5.1 General .....	7
5.2 Identification area.....	10
5.3 Content areas.....	10
6 Lines .....	11
6.1 Types of line.....	11
6.2 Width of lines .....	11
6.3 Space between lines .....	11
6.4 Leader lines and reference lines.....	11
7 Reference designations .....	12
7.1 Introduction.....	12
7.2 General .....	12
7.3 Boundary frames .....	14
7.4 Transition .....	15
7.5 Objects in a sheet.....	16
8 Port designations .....	17
9 Location references .....	18
10 Technical data and explanatory notes .....	19
10.1 Components and devices .....	19
10.2 Flow paths.....	19
10.3 Explanatory notes .....	19
10.4 Supplementary diagram symbols.....	19
11 Graphical symbols .....	20
11.1 General .....	20
11.2 Creation of new symbol examples .....	20
11.3 Features of symbols.....	20
11.4 Use of symbols in diagrams.....	22
12 Connections .....	26
12.1 General .....	26
12.2 Significant connections .....	26
12.3 Simplified representation .....	26
12.4 Joints .....	26
12.5 Intersections .....	27

12.6	References for interrupted connecting lines .....	27
12.7	Objects with two or more system connections .....	27
13	Layout of diagrams .....	28
13.1	General aspect .....	28
13.2	Functional layout .....	28
13.3	Topographical layout .....	30
14	Types of diagram .....	30
14.1	General.....	30
14.2	Overview diagrams .....	30
14.3	Function diagrams.....	31
Annex A	(informative) Diagram symbols .....	34
Annex B	(informative) Document type designation and content of information.....	35
Bibliography	.....	37

## Foreword

ISO (the International Organization for Standardization) is a worldwide federation of national standards bodies (ISO member bodies). The work of preparing International Standards is normally carried out through ISO technical committees. Each member body interested in a subject for which a technical committee has been established has the right to be represented on that committee. International organizations, governmental and non-governmental, in liaison with ISO, also take part in the work. ISO collaborates closely with the International Electrotechnical Commission (IEC) on all matters of electrotechnical standardization.

International Standards are drafted in accordance with the rules given in the ISO/IEC Directives, Part 2.

The main task of technical committees is to prepare International Standards. Draft International Standards adopted by the technical committees are circulated to the member bodies for voting. Publication as an International Standard requires approval by at least 75 % of the member bodies casting a vote.

Attention is drawn to the possibility that some of the elements of this document may be the subject of patent rights. ISO shall not be held responsible for identifying any or all such patent rights.

ISO 15519-1 was prepared by Technical Committee ISO/TC 10, *Technical product documentation*, Subcommittee SC 10, *Process plant documentation and tpd-symbols*.

ISO 15519 consists of the following parts, under the general title *Specification for diagrams for process industry*:

— *Part 1: General rules*

## Introduction

This part of ISO 15519 deals with preparation of diagrams and associated documents and data for process industry.

Together with rules for the preparation of diagrams and associated documents and data, this part of ISO 15519 includes rules and recommendations for the application of associated standards in diagrams, for example graphical symbols and reference designation. The following diagram gives an overview of interrelations between these standards.

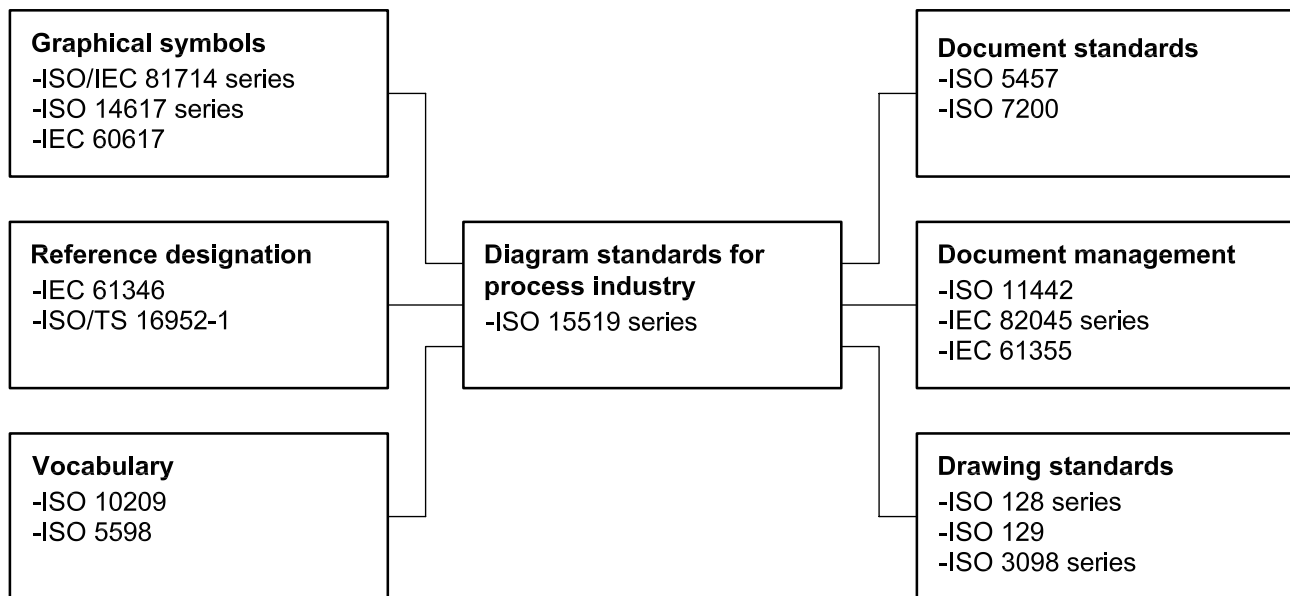

### Graphical symbols

In this part of ISO 15519 references are made to symbols and rules in the ISO 14617 series by using registration numbers. Three types of registration number are used in ISO 14617:

- 101 registration number for a symbol;
- R101 registration number for an application rule;
- X101 registration number for an application example.

When reference is made to ISO 14617, the description is in italics, e.g. “Symbol 255: *Circular motion*”.

Cross-references to referred symbols, rules and examples in the ISO 14617 series can be found in the registration number index in ISO 14617-1.

### Collective application standards

Technical committees, requiring a field specific standard, are allowed, in co-operation with ISO/TC 10, to develop their own collective application standard for preparation of diagrams in accordance with the rules given in this part of ISO 15519. Application standards should not be contradictory with respect to this source standard.

### Figures

Figures in this part of ISO 15519 are only examples for illustration of a given rule.

# Specification for diagrams for process industry —

## Part 1: General rules

### 1 Scope

This part of ISO 15519 provides general rules and guidelines for the preparation and presentation of information in diagrams for process industry.

### 2 Normative references

The following referenced documents are indispensable for the application of this document. For dated references, only the edition cited applies. For undated references, the latest edition of the referenced document (including any amendments) applies.

ISO 128-20 *Technical drawings — General principles of presentation — Part 20: Basic conventions for lines*

ISO 128-21, *Technical drawings — General principles of presentation — Part 21: Preparation of lines by CAD systems*

ISO 128-22, *Technical drawings — General principles of presentation — Part 22: Basic conventions and applications for leader lines and reference lines*

ISO 3098-0, *Technical product documentation — Lettering — Part 0: General requirements*

ISO 3098-5, *Technical product documentation — Lettering — Part 5: CAD lettering of the Latin alphabet, numerals and marks*

ISO 5457, *Technical product documentation — Sizes and layout of drawing sheets*

ISO 6428, *Technical drawings — Requirements for microcopying*

ISO 7200, *Technical product documentation — Data fields in title blocks and document headers*

ISO 14617 (all parts), *Graphical symbols for diagrams*

ISO/TS 16952-1, *Technical product documentation — Reference designation system — Part 1: General application rules*

ISO 80000 (all parts), *Quantities and units*

ISO 81714-1:1999, *Design of graphical symbols for use in the technical documentation of products — Part 1: Basic rules*

IEC 81714-2, *Design of graphical symbols for use in the technical documentation of products — Part 2: Specification for graphical symbols in a computer sensible form, including graphical symbols for a reference library, and requirements for their interchange*

# ISO 15519-1:2010(E)

IEC 60617DB<sup>1)</sup> *Graphical symbols for diagrams*

IEC 61355-1, *Classification and designation of documents for plants, systems and equipment — Part 1: Rules and classification tables*

IEC 61666, *Industrial systems, installations and equipment and industrial products — Identification of terminals within a system*

IEC 81346-1:2009, *Industrial systems, installations and equipment and industrial products — Structuring principles and reference designations — Part 1: Basic rules*

IEC 82045-2, *Document management — Part 2: Metadata elements and information reference model*

## 3 Terms and definitions

For the purposes of this document, the following terms and definitions apply.

### 3.1 Basic terms

#### 3.1.1 document

fixed and structured amount of information intended for human perception which can be managed and interchanged as a unit between users and systems

NOTE 1 The term document is not restricted to its meaning in a legal sense.

NOTE 2 A document can be designated in accordance with the type of information and the form of presentation, for example overview diagram, connection table, function chart.

NOTE 3 Adapted from ISO/IEC 8613-1:1994, definition 3.58.

#### 3.1.2 document type

document defined with respect to its specific content of information and form of presentation

EXAMPLE Overview diagram, parts lists, etc.

NOTE Adapted from IEC 62023:2000, definition 3.2.2.

#### 3.1.3 documentation

continuous and systematic compilation and processing of recorded information for the purpose of storage, classifying, retrieval, utilization or transmission

[ISO 5127:2001, definition 1.2.01]

#### 3.1.4 process

sequence of chemical, physical or biological operations for the conversion, transport or storage of material or energy

[ISO 10628:1997, definition 3.1]

---

1) DB = Database. (12-month subscription to online database comprising parts 2 to 13 of IEC 60617.)



**3.1.5****process plant**

facilities and structures necessary for performing a process

[ISO 10628:1997, definition 3.6]

**3.1.6****graphical symbol**

visually perceptible figure used to transmit information independently of language

[ISO 81714-1:1999, definition 3.1]

**3.2 Document types****3.2.1****drawing**

technical information, given on an information carrier, graphically presented in accordance with agreed rules and usually to scale

[ISO 10209-1:1992, definition 2.11]

**3.2.2****diagram**

technical document showing the functions of the objects composing a system and their interrelations using graphical symbols

**3.2.3****overview diagram**

diagram providing a comprehensive view of an object with low degree of detailing

[IEC 61082-1:2006, definition 3.4.1]

**3.2.4****network map**

overview diagram showing a network on a map

EXAMPLE Networks for district heating, district cooling, natural gas including generating stations and sub-stations.

**3.2.5****block diagram**

overview diagram predominantly using block symbols

EXAMPLE Rectangular symbols.

**3.2.6****process flow diagram**

diagram illustrating the configuration of a process system or process plant by means of graphical symbols

**3.2.7****function diagram**

diagram providing information about the functional behaviour of a system

NOTE Adapted from IEC 61082-1:2006, definition 3.4.2.

**3.2.8****circuit diagram**

diagram providing information about the circuitry of an object(s)

[IEC 61082-1:2006, definition 3.4.3]

**3.2.9**

**pipng and instrumentation diagram**

**P&I D**

process flow diagram representing the technical realization of a process system by means of graphical symbols for equipment, connections and process measurement and control functions

**3.2.10**

**installation diagram**

document showing the location of the components of an installation and their interconnections by means of graphical symbols

**3.2.11**

**parts list (document)**

list of elements of an object(s)

[IEC 62027:2000, definition 3.3.1]

**3.3 Reference designation**

**3.3.1**

**reference designation**

identifier of a specific object with respect to the system of which the object is a constituent, based on one or more aspects of that system

[IEC 81346-1:2009, definition 3.7]

**3.3.2**

**object**

entity treated in the process of design, engineering, realization, operation, maintenance and demolition

NOTE 1 The entity can refer to a physical or non-physical “thing”, or to a set of information associated with it.

NOTE 2 Depending on its purpose, an object can be viewed in different ways called “aspects”.

[IEC 81346-1:2009, definition 3.1]

**3.3.3**

**aspect**

specific way of selecting information on or describing a system or an object of a system

EXAMPLES: what the system or object is doing (function viewpoint);  
how the system or object is constructed (product viewpoint);  
where the system or object is located (location viewpoint).

[IEC 81346-1:2009, definition 3.6]

**3.3.4**

**multi-level reference designation**

reference designation derived from a structure path through an overall system

[IEC 81346-1:2009, definition 3.9]

**3.3.5**

**reference designation set**

set of reference designations of which at least one unambiguously identifies the object of interest

[IEC 81346-1:2009, definition 3.10]

## 4 Documentation principles

### 4.1 General

This clause introduces the standard and gives an overview of the content with focus on important issues. It also, to a certain degree, gives information about subjects which are dealt with in other standards dealing with documentation of technical products.

This clause also describes diagrams as part of the technical product documentation relations to, for example, the life-cycle aspect, reference designation, interrelations to electrical and instrumentation and control disciplines, etc.

### 4.2 Technical product documentation

#### 4.2.1 General

Technical product documentation constitutes all technical information about a product or a system in the form of drawings, diagrams, parts lists, reference designations, technical specifications, etc. Diagrams as specified in this part of ISO 15519 are part of this technical product documentation.

The technical product documentation for a product or a system shall be structured and each document classified to ease creation of references between documents in order to ease navigation within the documentation. IEC 61355 deals with classification of documents. IEC 61355 to a certain degree applies to the ISO field.

In the matrix of technical product documentation, diagrams and associated information, for example reference designation and parts lists, constitutes the functional and structural part of the documentation of the product or system, which makes diagrams one of the most important documents.

#### 4.2.2 Interrelations between diagrams for different purposes

A typical system or process plant consists of the process system, instrumentation and control system and electrical power supply system; see Figure 1.

The matching process documentation consists of process diagrams, instrumentation and control diagrams and electrical power supply diagrams.

The interface between the disciplines shall be co-ordinated in order to secure, unambiguously, exchange of information. Documentation specifications shall specify the types of document which should apply for information interchange between the disciplines.

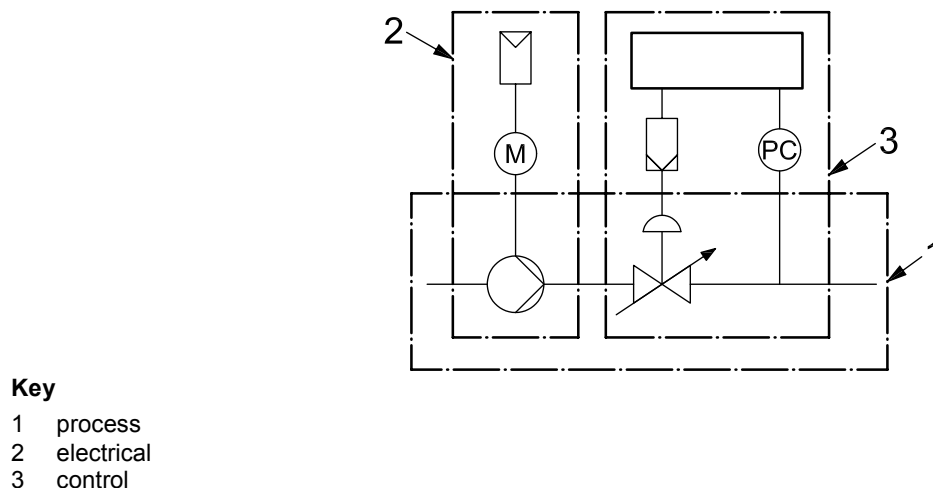

Figure 1 — Interrelations between process, electrical and instrumentation and control

## 4.2.3 Life cycle aspects

Diagrams should be planned and developed with due consideration to the intended use during the life cycle phases. The result is that diagrams should not only be prepared for engineering and manufacturing phases but also for operation and maintenance phases.

Engineering and manufacturing companies should be aware that a diagram is not only used for a short period during engineering and manufacturing but for several years during operation and maintenance phases.

ISO 15226 gives recommendations for documentation during the life cycles of a product.

## 4.2.4 Reference designation

Each object in a diagram should be assigned a unique reference designation, which should appear from a parts list or a database common to the process plant.

This part of ISO 15519 deals with representation of reference designation according to IEC 81346-1 which is a standard common to both IEC and ISO fields.

## 4.2.5 Documentation guidelines

In order to secure homogeneity and legibility of all diagrams in a process plant typically consisting of several sub-systems, it is recommended – for each diagram type – to establish a documentation guideline in which requirements for sheet sizes, graphical symbols, connections, reference designation, etc., are specified. Examples of typical diagrams for the actual process plant should be included.

## 4.3 Representation aspects

### 4.3.1 General

Presentation of information in diagrams shall be unambiguous and well arranged in order to ensure legibility. Further, the intended or foreseeable conditions of use should be taken into consideration when preparing diagrams. The following aspects are of importance for legibility:

- the intended medium for presentation, for example paper or screen;
- the use of unambiguous graphical symbols;
- the amount of information in one sheet and eventual split up into more sheets;
- the size of the sheet;
- the presentation of technical information;
- the use of reference designation.

### 4.3.2 Document sheet split up

In this part of ISO 15519, split up of the document sheet into two areas is introduced: an identification area that contains document information for identification and management of the document, for example title block with content, metadata, etc., and a content area that contains the technical information of the document in the form of graphical symbols, reference designation, etc.

### 4.3.3 Presentation forms

This part of ISO 15519 mainly focuses on diagrams presented on paper. When diagrams are prepared predominately for screen presentation, special attention should be taken in order to secure legibility with respect to, for example:

- colours;
- screen resolution;
- distance between and thickness of lines.

## 4.4 Focus area in this part of ISO 15519

The technical part of this part of ISO 15519 covers four focus areas:

- general document rules, for example document sheet, lines, lettering, etc. (Clause 5);
- diagram specific subjects, for example reference designations, graphical symbols, connections, port designations, technical data, location reference system, etc. (Clauses 6 to 12);
- layout principles and layout rules for diagrams, etc. (Clause 13);
- types and contents of diagrams (Clause 14).

## 5 Document sheets

### 5.1 General

#### 5.1.1 Document sheet sizes

Document sheet sizes shall conform to ISO 5457. The following aspects shall be considered for selection of document sheet size:

- the amount of information to be presented in the sheet to ensure legibility and overview;
- the composition and complexity of the design;
- the possibility of using a smaller size, but with an increased number of sheets;
- the size of a specific type of document should not be changed within a document set.

Elongated formats should not be used. However, when necessary, the elongation shall be in accordance with ISO 5457. Format A3 is thus allowed, elongated to A2, A1 and A0.

#### 5.1.2 Borders, frames, centring and grid reference system

Border and frame markings shall comply with ISO 5457, which includes:

- centring marks for documents that are prepared for microfilming;
- grid reference system for location reference between documents, within documents and within sheets. The grid reference system consists of columns and rows. A zone is the cross-section of a column and a row. Columns are designated with numbers. Rows are designated with letters. See Figure 2.

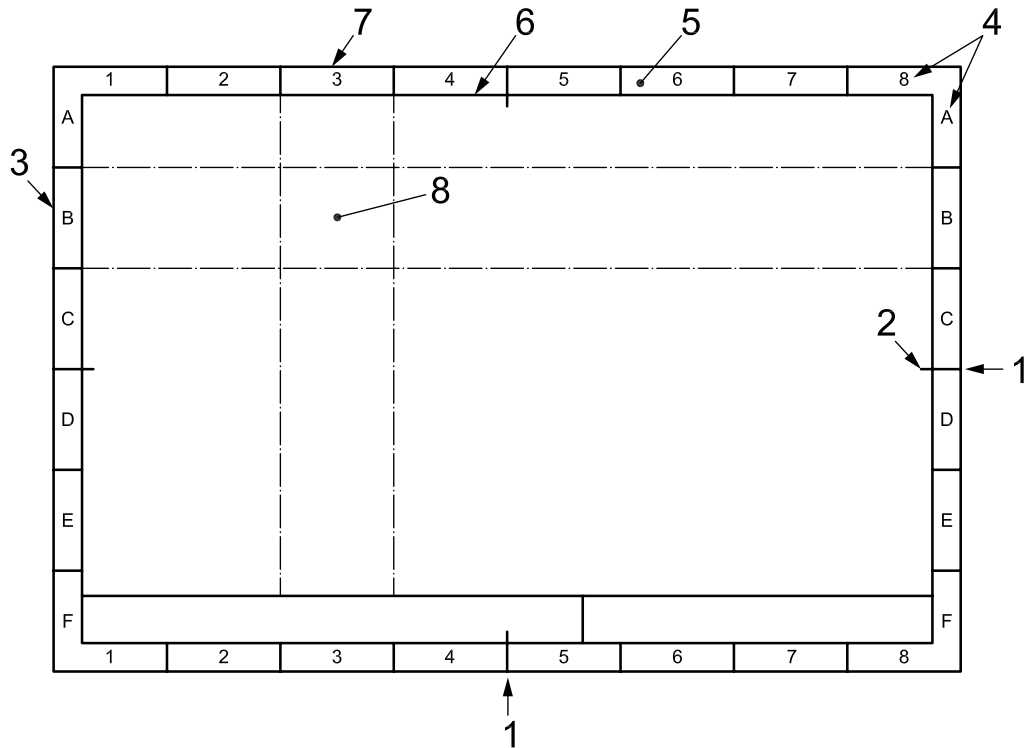

**Key**

- 1 viewing direction
- 2 centring marks
- 3 row B
- 4 grid reference system
- 5 grid reference border
- 6 frame
- 7 column 3
- 8 zone B3

**Figure 2 — Document sheet with border, frame and grid**

**5.1.3 Grid system, modules**

A diagram should be based on a grid system consisting of horizontal and vertical lines, not visible in the final document. The distance between the lines shall be one module (1M), where M shall be chosen from the series 2,0 mm, 2,5 mm, 3,5 mm, 5 mm, etc., in accordance with ISO 81714-2.

The connecting lines in the diagram shall coincide with the lines in the grid system or right between two adjacent grid lines. For more details, see ISO 81714-1.

**5.1.4 Lettering**

Lettering type B in accordance with ISO 3098-0 shall be used. Vertical letters shall be used, except for letter symbols for quantities, where sloped (inclined) letters should be used in accordance with ISO 80000.

The lettering height shall be at least 2,5 mm for diagrams of size A4 ... A2. For larger diagrams, the lettering height shall be at least 3,5 mm.

For CAx produced documents, lettering type CB according to ISO 3098-5 shall be used, when available.

### 5.1.5 Text orientation

Text shall be oriented horizontally or vertically corresponding to the reading directions viewed from the bottom edge or viewed from the right-hand edge of the document. See Figure 2.

Reference designations shall be oriented horizontally independent of symbol orientation.

### 5.1.6 Hyperlinks

Hyperlinks may be used as a supplement to location references (see Clause 9) to facilitate navigation between different sets of information, e.g. pages of a document, between documents or to external information sources.

### 5.1.7 Colours

If colours are used to represent different media or operation state of components, for example open or closed on-off valves, and the colour differentiation is not self-explanatory to the user, then the colours shall be explained in a note in the diagram or in a supporting document.

NOTE The use of colours for some specific purposes is given in ISO 3864-1, IEC 60204-1 and IEC 60073.

### 5.1.8 Microcopying

Documents that are intended to be microcopied shall comply with ISO 6428.

### 5.1.9 Document sheet split up

Each sheet shall be divided into two areas:

- an identification area;
- a content area.

The identification area shall be clearly separated from the content area, for example by a frame; see Figure 3.

Rules for the identification area are given in 5.2 and rules for the content area are given in 5.3.

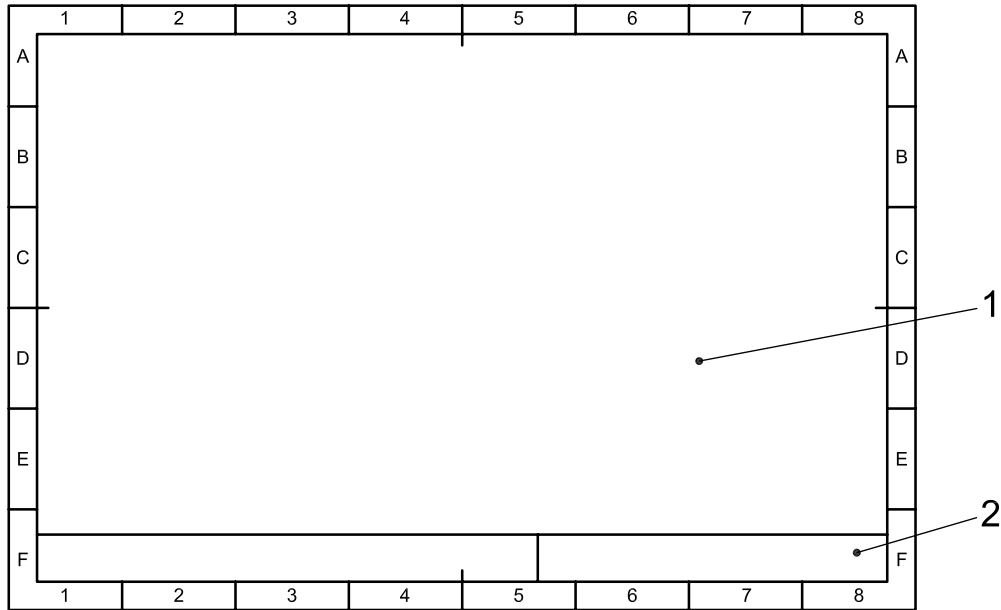

- Key**
- 1 content area
  - 2 identification area

**Figure 3 — Document sheet with content and identification area indications**

**5.2 Identification area**

**5.2.1 General**

Information in the identification area shall only comply with the document metadata as defined in IEC 82045-2.

Information belonging to the content of the diagram, for example explanatory notes to graphical symbols and reference designations, shall not be placed in the identification area.

**5.2.2 Title block**

The position of the title block in the document sheet shall comply with ISO 5457. The dimension and information contained within the title block shall comply with ISO 7200.

If a document is designated according to the IEC 61355 document classification system, then the title block shall include a field for that designation.

**5.2.3 Document identification numbers and sheet numbers**

Each diagram or associated document shall have an identification number placed in the title block. All the sheets in a multi-sheet diagram or associated document shall be numbered in a manner that will relate them to one another. Document identification numbers and sheet numbers shall be placed adjacent to each other.

**5.3 Content areas**

Information in the content area shall only comply with the content of the document, for example graphical symbols and connections, explanatory notes, reference designation, technical data, etc.



## 6 Lines

### 6.1 Types of line

The types of line shall comply with ISO 128-20.

Non-continuous lines, for example dashed dotted lines (ISO 128-20 line type 10), in CAx produced documents shall in addition comply with ISO 128-21.

Lines that are parts of a graphical symbol shall be drawn in accordance with ISO 81714-1.

A line forming a boundary frame used to indicate a grouping of symbols shall be a dashed dotted line.

### 6.2 Width of lines

The width of lines of a final diagram on paper or equivalent media shall be at least 0,18 mm and should be chosen from the line widths specified in ISO 128-20 and Table 1.

**Table 1 — Width of lines in diagrams for typical fields of application**

Application field	Symbols Boundary frames	Connections
Fluid power	0,1 M	0,1 M
Process industry	0,1 M	0,2 M (0,4 M)

If two or more widths of line are used, the ratio between any two widths shall be at least 2:1.

### 6.3 Space between lines

The space between the edges of parallel lines should be at least twice the width of the lines, i.e. the centre-to-centre distance should be at least three times the line width. If the lines have different widths, the space should be at least twice the heavier line width.

For parallel connecting lines, the centre-to-centre distance should be at least 1 M. For connecting lines that have supplementary information, for example, signal designations, the distance shall be at least 2 M.

NOTE Connecting line is the name of the symbol for a pipeline, an electrical conductor, etc.

### 6.4 Leader lines and reference lines

Leader lines and reference lines indicating where notes or references apply shall be in accordance with the requirements of ISO 128-22.

Leader lines shall terminate:

- with a dot if it terminates within an object; see Figure 4 a);
- with an arrowhead if it ends on the outline of an object or a connection; see Figure 4 b) and c);
- with an oblique stroke if it ends at several parallel connections; see Figure 4 d).

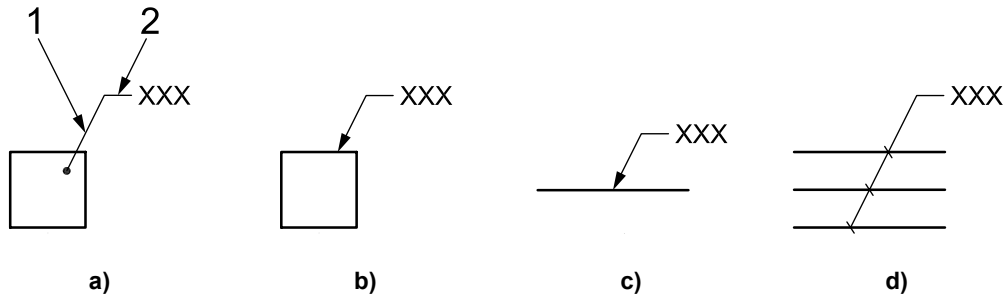

**Key**

- 1 leader line
- 2 reference line

NOTE The technical information can be placed at the end of the reference line, as shown in Figure 4 or above the reference line. See also ISO 128-22.

**Figure 4 — Types of termination of leader lines**

**7 Reference designations**

**7.1 Introduction**

In this part of ISO 15519, the reference designation principle in accordance with IEC 81346-1 and ISO/TS 16952-1 is used. Other reference designation principles may be used as long as they are agreed upon between involved parties.

**7.2 General**

**7.2.1 Reference designation general rules**

Each object (plant section, system, equipment, device, component, measuring point, etc.) represented in a diagram by a graphical symbol shall have an attached reference designation, which shall correspond to those in the parts list or the associated database.

The reference designation principle in IEC 81346-1 is based on three aspects of viewing the object depending on:

- what the object does – the function aspect;
- how the object is constructed – the construction aspect;
- where the object is located – the location aspect.

According to IEC 81346-1, the following reference designation prefix signs apply:

- = is used for function-oriented reference designations;
- is used for product-oriented reference designations;
- + is used for location-oriented reference designations.

**7.2.2 Multi-level reference designations**

According to IEC 81346-1, a multi-level reference designation, for example = A8 = Q1, may be presented as follows:

- 1 = A8 = Q1
- 2 = A8Q1
- 3 = A8.Q1

Presentation form 2, without intermediate signs, requires that the higher level reference designation ends with a number and the succeeding reference designation starts with a letter. In this part of ISO 15519, presentation form 1 is used.

**7.2.3 Location of reference designation for single objects**

The reference designation for single objects shall be located adjacent to the symbol. In order to allow space for connections to, for example, valve actuators, the reference designation shall be offset from the symbol centre lines. See Figure 5, which indicates optional positions of the reference designation. The locations with \* are preferred.

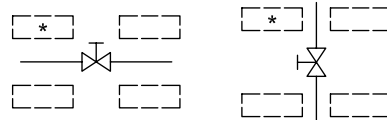

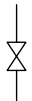

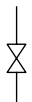
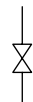

**Figure 5 — Locations of reference designation for single objects**

**7.2.4 Presentation of reference designations**

Objects may have a reference designation or a reference designation set.

A reference designation may consist of one or more aspects and shall be presented on a single line, for example: =D4–E5+F6. See Figure 6.

Reference designations		Possible graphical presentations	
		All presented on the same line	Each presented on one line
Reference designation	=D4–E5+F6	=D4–E5+F6 	=D4–E5+F6 
Reference designation sets	= A1	=A1/–B2/+C3 	A1 –B2 +C3 
	–B2		
	+C3		
	=G7–H8	=G7–H8/+J9 	=G7–H8 +J9 
	+J9		

**Figure 6 — Presentation of reference designation and reference designation sets**

A reference designation set consists of one or more individual reference designations of which at least one reference designation shall unambiguously identify the object. The rules for reference designation sets are described in 5.5 of IEC 81346-1:2009. When reference designation sets are presented on the same line, the different reference designations shall be separated by a solidus (/). Reference designation sets shall be graphically presented as illustrated in Figure 6.

**7.2.5 Location of reference designation and reference designation sets**

Reference designation for connections should be located above the connection with horizontal connecting lines and to the left of vertical connecting lines. They shall be oriented along or adjacent to the relevant connecting lines.

If it is not possible to place the reference designation adjacent to the connecting line, it shall be shown elsewhere in the content area with a leader line to the actual connecting line. See also 6.4.

**7.3 Boundary frames**

**7.3.1 Boundary frame geometry**

Boundary frames [see Figure 7 a)], shall consist of horizontal and vertical dashed dotted lines in accordance with 6.1. Geometrically, boundary frames are not limited to squares and rectangles; see Figure 7 b).

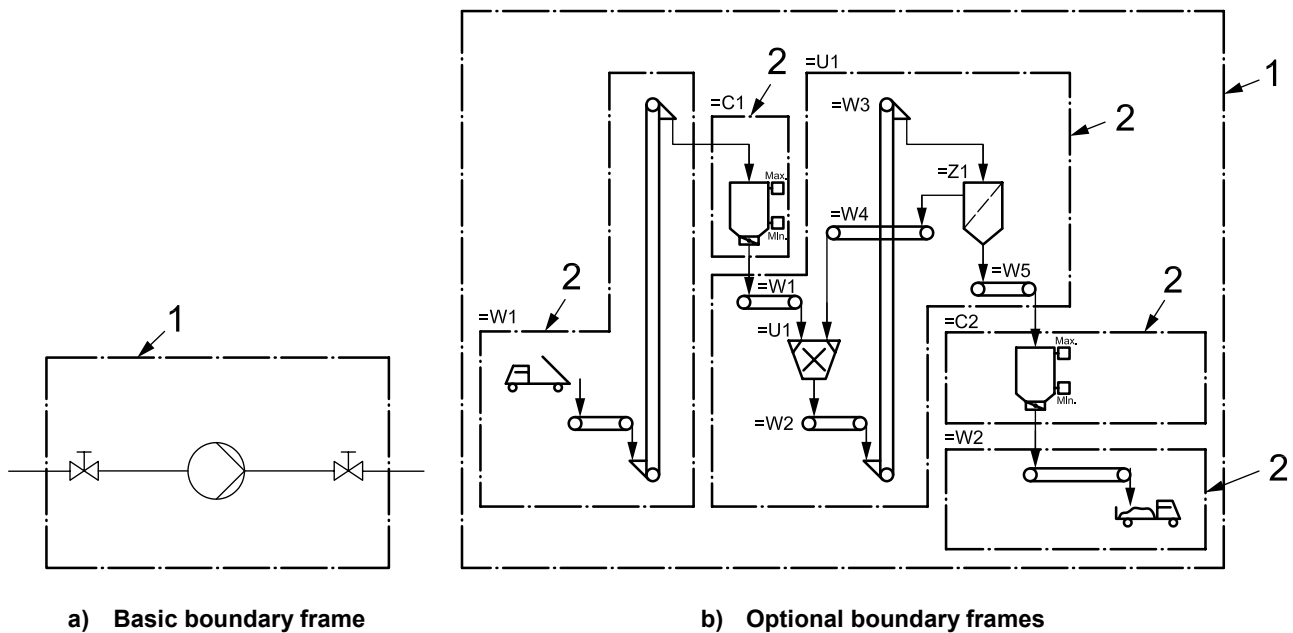

- Key**
- 1 basic boundary frame
  - 2 optional boundary frames

**Figure 7 — Boundary frame geometry**

**7.3.2 Application rules**

A boundary frame shall represent an object or grouping of objects. The objects within the boundary frame shall be constituents of the object represented by the boundary frame.

When boundary frames are used to represent objects with the same common initial reference designation, the objects within the boundary frame shall be represented without the common initial reference designation. See, for example, Figure 8 a).

A boundary frame may also be used to make reference to a more detailed document for an object or group of objects. When a boundary frame is used for reference purposes, a reference should be given inside the boundary frame. When possible, the reference should be placed in the bottom of the boundary frame and to the left. See, for example, Figure 8 b).

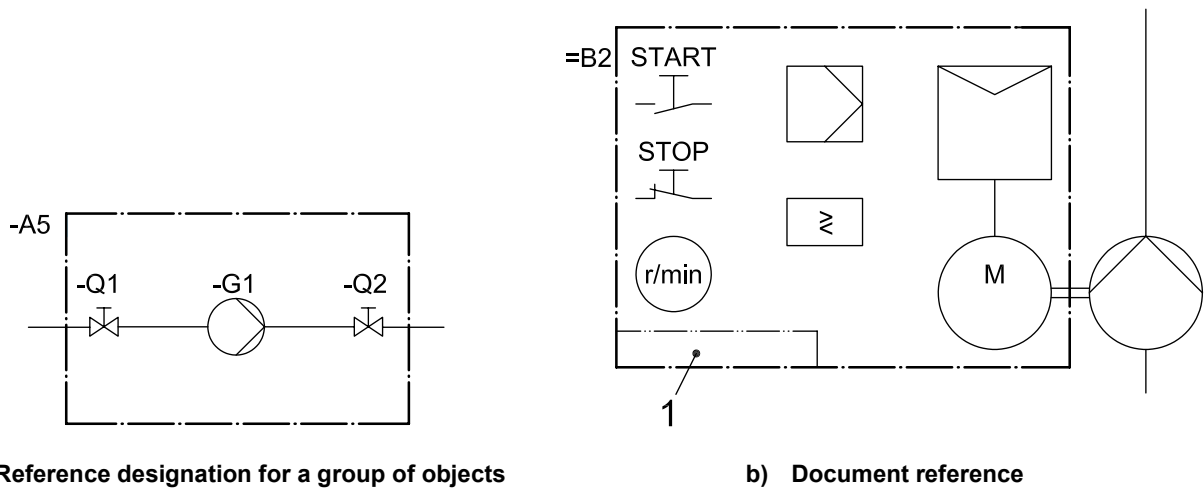

**Key**

1 marking "See document XXXX"

**Figure 8 — Application examples of boundary frames**

**7.3.3 Location of reference designation**

The reference designation shall be located outside and at the upper left corner of the boundary frame, either above the horizontal boundary line or to the left of the vertical boundary line; see Figure 9 a).

When boundary frames are located with coincident boundary lines, for example fluid power cartridge valves, the common initial reference designations may be located within each boundary frame in the upper left corner surrounded by a boundary line; see Figure 9 b).

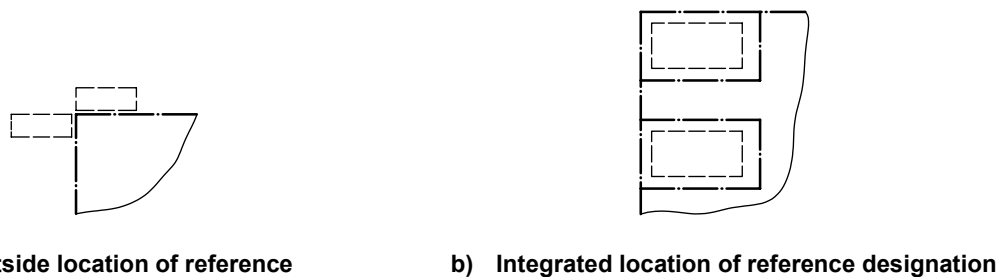

**Figure 9 — Locations of reference designations**

**7.3.4 Boundary frame application exclusion**

The boundary frame principle does not apply to diagrams where the connections (pipelines) have reference designations, as the connections cross the boundary lines. For such diagrams, a presentation principle with full reference designation for each object is recommended. See Figure 11 a).

**7.4 Transition**

Normally, a complete reference designation consists of a string of reference designations of the same type, for example, -A2-A6-V3. However, in some cases, a transition between various types of reference designations may be used in accordance with IEC 81346-1.

When a unit or group happens to be a transition object, i.e. the object where a transition applies, the reference designation for that object should end with the prefix sign that applies to the reference designations, which has to be linked to the reference designation for the unit or group. For example, the reference designation for a transition object =S1 containing objects with the reference designations -Q1, -Q2, -V1, etc., shall be supplemented, thus =S1-. See Figure 10.

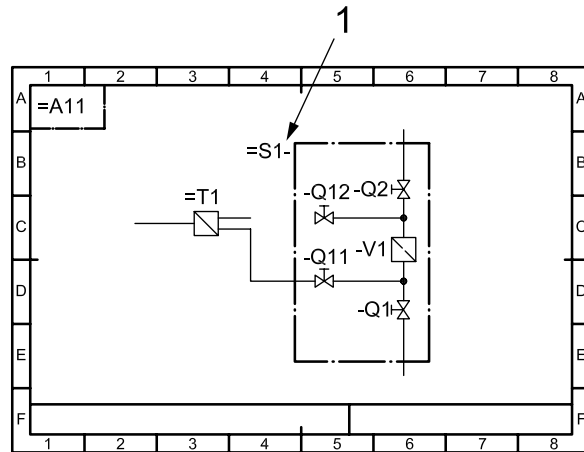

**Key**  
 1 transition sign

**Figure 10 — Transition**

**7.5 Objects in a sheet**

**7.5.1 Reference designations with same in front initial portion**

Objects in a sheet shall be identified with the full reference designation. See Figure 11 a).

When the sheet contains objects with the same common initial portion which applies to all the objects in the sheet, this common initial portion may be shown only in the upper left corner of the content area, separated from the rest of the content area by a boundary frame line. See Figure 11 b).

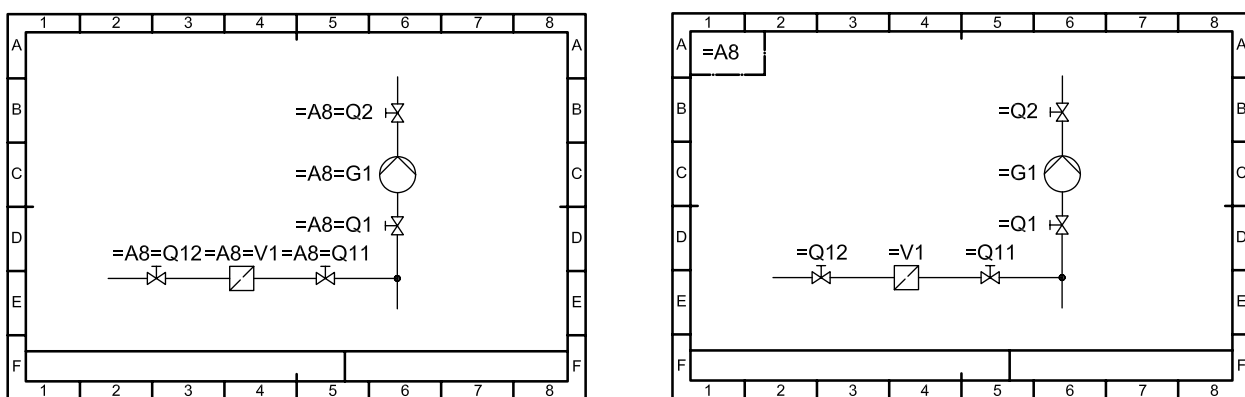

**a) Full reference designation**

**b) Common initial portion**

**Figure 11 — Example of reference designations with a common initial portion**

**7.5.2 Reference designations with different in front initial portions**

When the sheet contains groups of objects with different in front initial portions, the groups may be presented with their full reference designations as illustrated in Figure 12 a) or by using the boundary frame technique,

where the objects constituting a group are framed by a boundary line with the in front initial reference designation portion placed outside the boundary frame. Inside the boundary frame, the objects constituting the group are presented with the remaining part of their reference designations. See Figure 12 b).

The boundary frame technique contributes to improving legibility of diagrams, when the technique is appropriate.

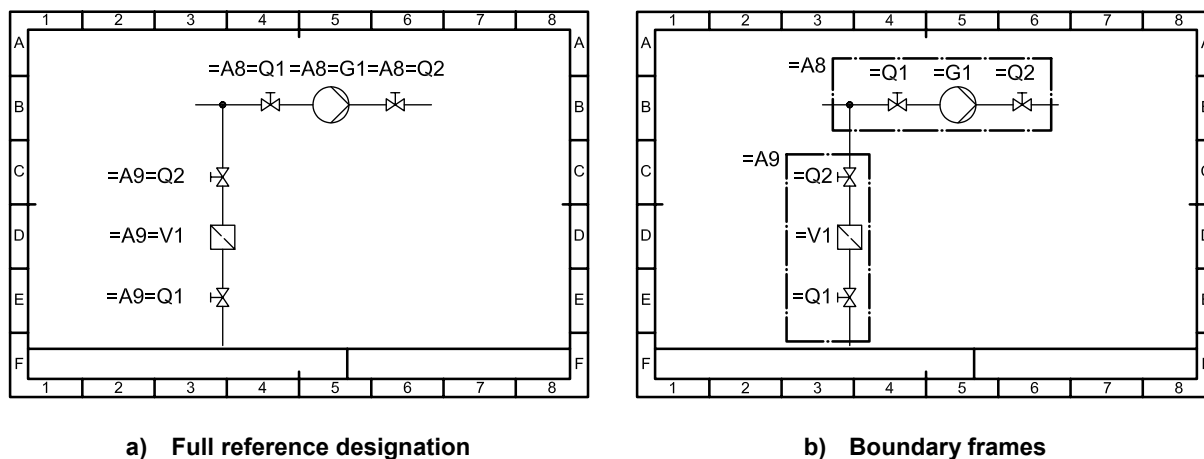
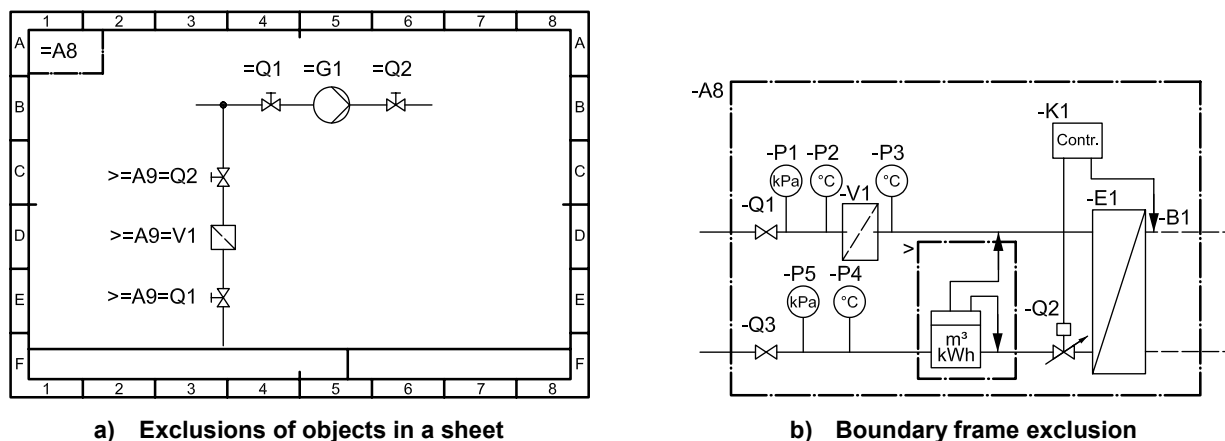

**Figure 12 — Examples of objects with different common initial portions in their reference designations**

### 7.5.3 Reference designation exclusions, greater than sign

When it is necessary to show objects in a sheet not belonging to the common initial portion, the excluded reference designations shall start with the greater than sign (>), indicating that the reference designations are not to be linked with the reference designation common to the other objects in the sheet. See Figure 13 a).

The greater than sign may also be used to illustrate if an object is excluded from an object or group of objects, [see example in Figure 13 b)], which illustrates a heating unit in which the energy meter is not a part of the manufacturer's supply, but will be installed later.



**Figure 13 — Exclusions by using > sign**

## 8 Port designations

Port designations of a component or device shall be located outside the outline of a symbol and the boundary frame of a unit, adjacent to the presentation of the port. They should be located above the port with horizontal connecting lines and to the left of vertical connecting lines. They shall be oriented along or adjacent to the relevant connecting lines. See Figure 14.

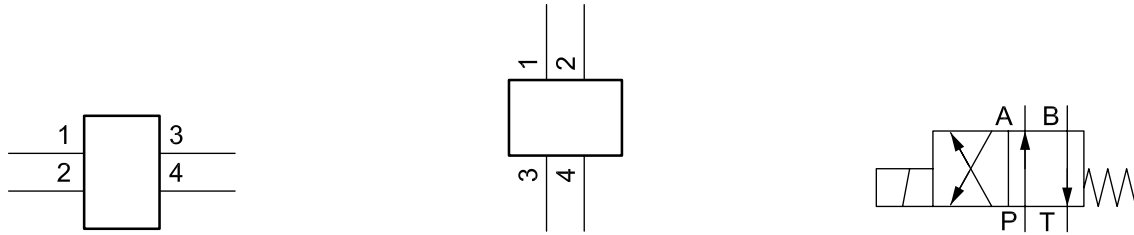

Figure 14 — Port designations

When the component or device is designated a reference designation, an unambiguous identifier of a port of that component or device shall consist of the reference designation and the port designation shall be separated with a colon (:), in accordance with IEC 61666. See Figure 15.

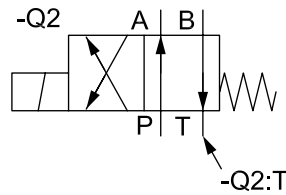

Figure 15 — Combination of reference and port designations

### 9 Location references

For reference to a document, to a sheet of a document, or to a column, a row or a zone on a sheet, the grid reference system described in 5.1.2 shall be used.

The following signs shall be used for creating location references:

- solidus (/) for identification of a sheet;
- full stop (.) for identification of a column, a row or a zone in a sheet.

The location reference shall be presented in following sequence: document — sheet — column, row or zone.

Examples are shown in Table 2.

Table 2 — Application examples of the use of document location references

Location reference to		Location reference
Other documents	Zone B3 on a single-sheet diagram No. 4334	4334/.B3
	Zone B3 on sheet 12 of multi-sheet diagram No. 7569	7569/12.B3
Same document	Another sheet in the same document	/2
	Zone B3 on sheet 12	/12.B3
Same sheet	Row B on the same sheet	/.B
	Column 3 on the same sheet	/.3
	Zone B3 on the same sheet	/.B3

NOTE For electrotechnical documents, the rules in IEC 61355 apply.



## 10 Technical data and explanatory notes

### 10.1 Components and devices

Technical data about components and devices should normally not be given in diagrams but in parts lists or attached to the reference designation in a document or a database.

However, characteristic data necessary to understand the functions can also be given in the diagram. Such data should be placed adjacent to the symbol or the boundary frame. If there is not enough space, such data should be linked to the symbol with a leader and reference line in accordance with 6.4.

### 10.2 Flow paths

Technical data about flow paths should be included. Such data may include design and operation data, for example pressure, temperature, flow or media. Data may be represented:

- with a reference line as illustrated in Figure 16 a); different types of data should be separated with a comma;
- with a table connected to the flow path with a leader line; specification of content in the individual cells should be given in the upper right corner of the content area. See Figure 16 b).

Symbols for quantities and units shall be in accordance with ISO 80000.

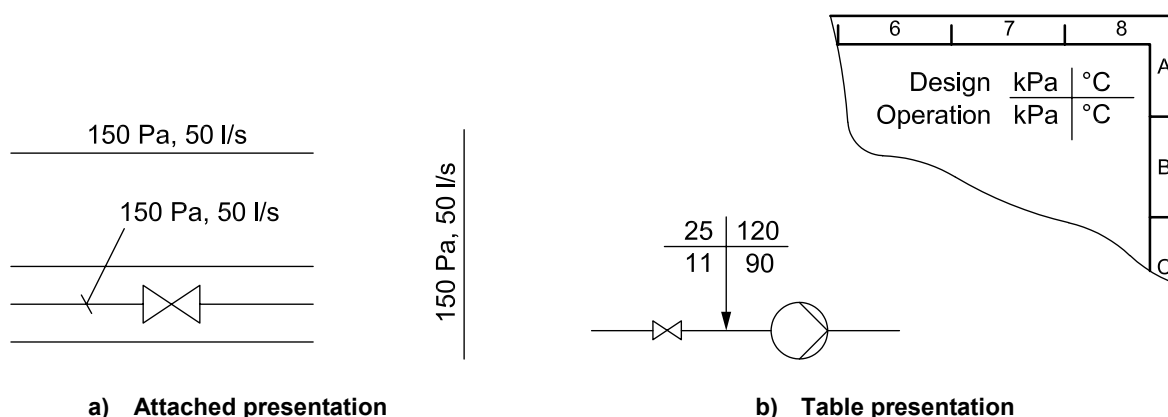

Figure 16 — Presentation of technical data

### 10.3 Explanatory notes

An explanatory note shall be used when the meaning cannot otherwise be conveyed. The note should be placed adjacent to where it applies, or a reference should be made to a note placed near the edge of the diagram sheet. In the case of multi-sheet diagrams, all notes of general character should appear on one of the first sheets.

### 10.4 Supplementary diagram symbols

In diagrams, there might be a need for permanent or temporary indications by using symbols, for example:

- indication of limit of supply;
- indication of change of piping class.

Symbols for permanent or temporary indications in diagrams are given in Annex A.

## 11 Graphical symbols

### 11.1 General

#### 11.1.1 Choice of symbol

Graphical symbols representing objects shall conform to ISO 14617 and IEC 60617. Examples may be taken from collective application standards of ISO 14617.

Symbols for CAx application shall in addition conform to ISO 81714-2.

#### 11.1.2 Symbol size

The symbols in ISO 14617 are shown in a grid system with module  $M = 2,5$  mm. The proportions of graphical symbols may be modified according to the requirements of ISO 81714-1; see also 11.4.1.

#### 11.1.3 Line width in graphical symbols

The normal line width of graphical symbols is  $0,1 M$ , according to ISO 81714-1. When the size of a symbol is changed, the line width shall be unchanged.

NOTE With  $M = 2,5$  mm, the line width for graphical symbols will be  $0,25$  mm.

### 11.2 Creation of new symbol examples

If the desired symbol does not appear in the ISO 14617 series, then it should be constructed by combining basic symbols and/or symbols with supplementary information from the ISO 14617 series.

### 11.3 Features of symbols

#### 11.3.1 Symbols with movable parts

In diagrams, components and devices shall be shown in the following operational states.

- a) General purpose valves without automatic return to a certain position, which does not indicate the operational state of the valve (open or closed), shall be regarded as closed.
- b) For general purpose valves with actuators, the imagined direction of movement of the symbol for the link between the valve and that of the actuator shall be from the valve at opening and towards the valve at closing, independent of valve construction (linear or rotary).
- c) General purpose valves with automatic return to their at-rest position shall be regarded as being in that position, i.e. either closed or open. Symbol 654: *Automatic return device* represents automatic return to at-rest position. The apex of symbol 654 shall point towards the valve symbol if the valve is closed when in the at-rest position [see Figure 17 a) left], and from the valve symbol if the valve is open when in the at-rest position [see Figure 17 a) right].
- d) For valves for fluid power systems, for example symbol X 2161: *Manually operated directional control valve with spring return to resting position*, the rules according to b) and c) above apply in principle. However, the imagined directions are arbitrary since the symbol itself indicates the actual position or state of the valve. See Figure 17 b).

NOTE Graphical symbols for fluid power valves are constructed of squares/spools, each representing a valve position. The spool position with port symbols is the at-rest/non-activated position of the valve.

- e) Electrical contacts operated by a valve to report the position of the valve shall be shown in the position (open or closed) they take on when a valve according to a) above is in its closed position and when a valve according to c) above is in its at-rest position. See Figure 18 a). For valves according to d) above, the contacts shall be shown in the position that corresponds to the position of the valve.
- f) Pilot switches for, for example, temperature, pressure, speed, flow-rate and level should normally be shown in an appropriate position, specified in the diagram. If possible, the contacts of a pilot switch for speed should be shown in the position they take on at zero speed (standstill), the contacts of a pilot switch for flow-rate at zero flow, and a pilot switch for lowest level, for example empty tank. See Figure 18 b). For a pilot switch for temperature or pressure no recommendations can be given.

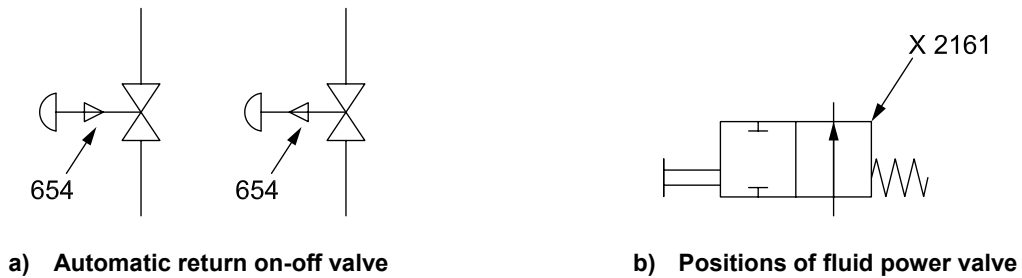
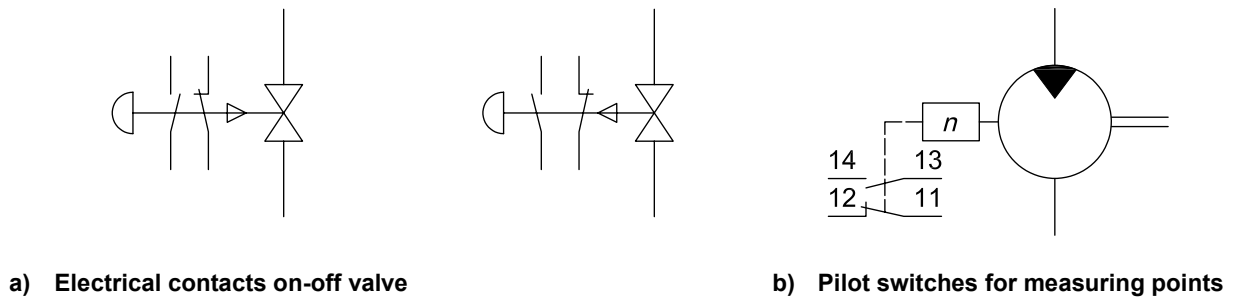

Figure 17 — Examples of valves with movable parts



NOTE 1 Rules for the choice of operational state for electrotechnical components and devices are given in IEC 61082-1.

NOTE 2 In IEC 61082-1, the imagined direction of contacts in relays and control switches upwards or to the right is used when the relay or control switch is being actuated. This method should also be used when contacts, for example in pilot switches, are shown in a diagram prepared according to this part of ISO 15519. However, this is not always possible due to the rules for the direction of the mechanical link with general purpose valves, given in this clause.

Figure 18 — Electrical contacts and pilot switches

### 11.3.2 Symbols representing functions and products

Graphical symbols can represent products and/or functions. Examples of graphical symbols representing products in the form of hardware are symbol 2301: *Liquid pump* and symbol 2101: *Two-way valve*. See Figure 19 a). Examples of graphical symbols representing functions are symbol 124: *Hysteresis* and symbol 144: *Automatic operation*. See Figure 19 b).

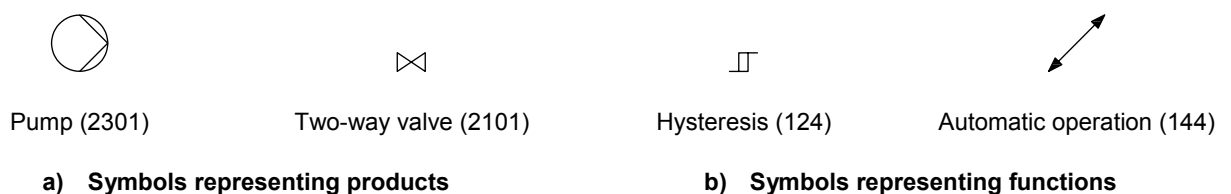

Figure 19 — Examples of graphical symbols representing products or functions

Some symbols may represent either a product or a function performed depending on the application. Symbol 654: *Automatic return device* [see Figure 20 a)], is an example of this dual symbol property. Alone, the symbol represents the product, which brings, for example, a valve back to its resting position. However, if the symbol is included in a valve designed so that the valve returns automatically to its at-rest position, the symbol only gives the information of that feature and should then be regarded as a symbol for a function. See Figure 20 b) showing a membrane operated valve which will open in case of failure of actuating energy.

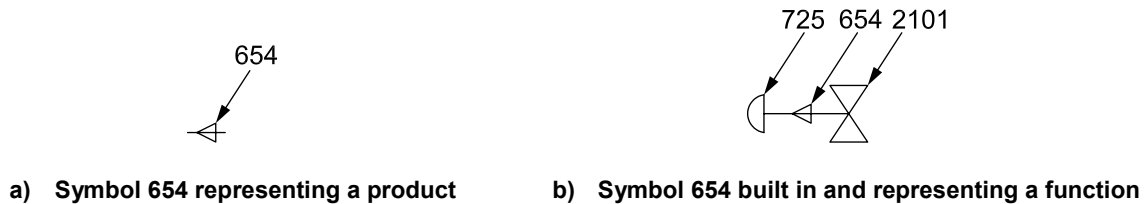

Figure 20 — Example of symbol with dual property depending on application

## 11.4 Use of symbols in diagrams

### 11.4.1 Modification of proportions

The proportions of a symbol may be modified, if necessary. The extent of modification of the symbol shape must not result in it being impossible to recognise the symbol. The most common modifications of proportions of graphical symbols are as follows.

- Enlargement by scaling, in order to give space for insertion of text. See Figure 21 a) where symbol 822: *Measuring instrument*, is enlarged, according to application rule R831, in order to give space for the chemical formula NaCl.
- Reduction by scaling, in order to emphasise a certain aspect. See Figure 21 b) where the smaller symbol represents an auxiliary pump for the bearing lubrication system for the main pump.
- Prolongation in order to give space for longer inserted text than is possible in the original symbol. See Figure 21 c), where symbol 1041: *Information-processing function*, is elongated, according to application rule R1043, to give space for the processing function designation: TJRA

NOTE Letter codes for processing function application designations can be found in ISO 14617-6.

When symbols containing digits and/or letters are subjected to scaling then the digits and/or letters should be replaced by digits and/or letters of a size corresponding to those in the document or a new symbol with scaled graphics should be developed.

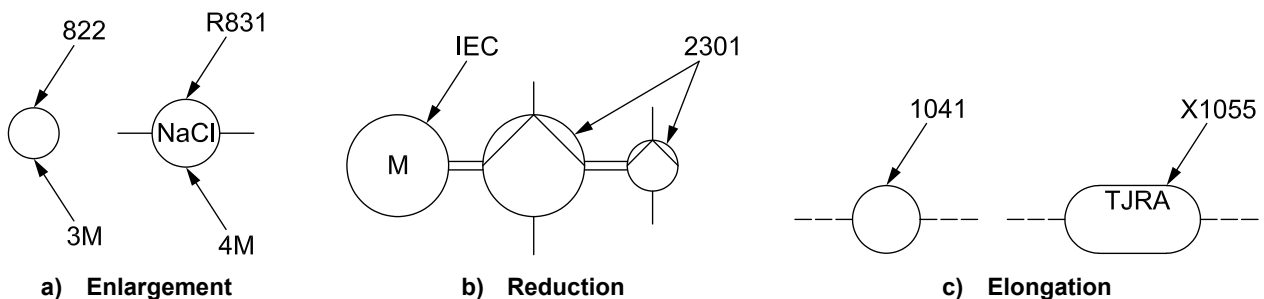

Figure 21 — Examples of size modification of graphical symbols









**11.4.2 Orientation of graphical symbols**

A graphical symbol may need to be subject to turning or mirroring or a combination of the two if necessary, in order to fit into the actual layout of the diagram.

Rules for turning and mirroring are given in ISO 81714-1. Figure 22 a) shows an example of variants (turning and mirroring) of symbol 255: *Circular motion*.

Exceptions for turning are symbols representing components or devices where gravity is a functionality, for example symbol 2061: *Open tank* or symbol X 2618: *Cyclone separator*; see Figure 22 b). Such symbols must not be turned.

Attention is drawn to turning and mirroring of symbols containing digits and/or letters. If the symbol is turned to a position where it is not readable from the bottom line or the right-hand line then a new symbol should be created to the actual orientation.

Clockwise rotation	A 	B 	C 	D 
Anti-clockwise rotation	E 	F 	G 	H 

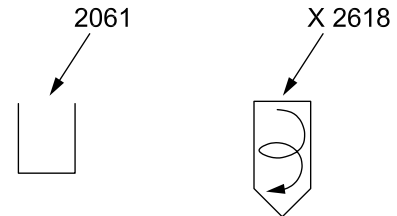

a) Eight variants of symbol 255

b) Symbols with gravity functionality

**Figure 22 — Orientation of graphical symbols**

**11.4.3 Indication of directions**

Most needs for graphical symbols for indicating directions in diagrams concern symbols for:

- mass flow;
- rectilinear and circular motion;
- propagation of energy or signal flow;
- working direction of fluid power.

For indicating direction of mass flow, symbols 241 (Form 1) and 242 (Form 2): *Direction in general, except for energy and signal flow*, should be used. Form 1 shall preferably be used for solid and bulk material flow, for example a conveyor. Form 2 shall preferably be used for fluid flow, for example a pipeline. See Figure 23 a). In a diagram all connections should be supplied with the symbols for indicating direction, where necessary for improving legibility.

Parallel connection shall be supplied with symbols for flow directions placed in groups with regular intervals. In case of alternative flow directions, symbol 245 (Form 1) and symbol 246 (Form 2): *Alternative direction in general, except for energy and signal flow*, shall be used. See Figure 23 b). When it is necessary to indicate the positive or normal direction, the arrowhead in this direction may be supplemented with a plus sign or any other symbol.

For indication of rectilinear motion, symbol 241: *Direction in general, except for energy and signal flow* and symbol 245: *Alternative direction in general, except for energy and signal flow*, shall be used. Attention is drawn to the need to differentiate between alternative direction motion and reciprocating motion. The latter shall be illustrated by symbol X 252: *Reciprocating motion*, consisting of two opposite pointing type 241 arrows. See Figure 23 c).

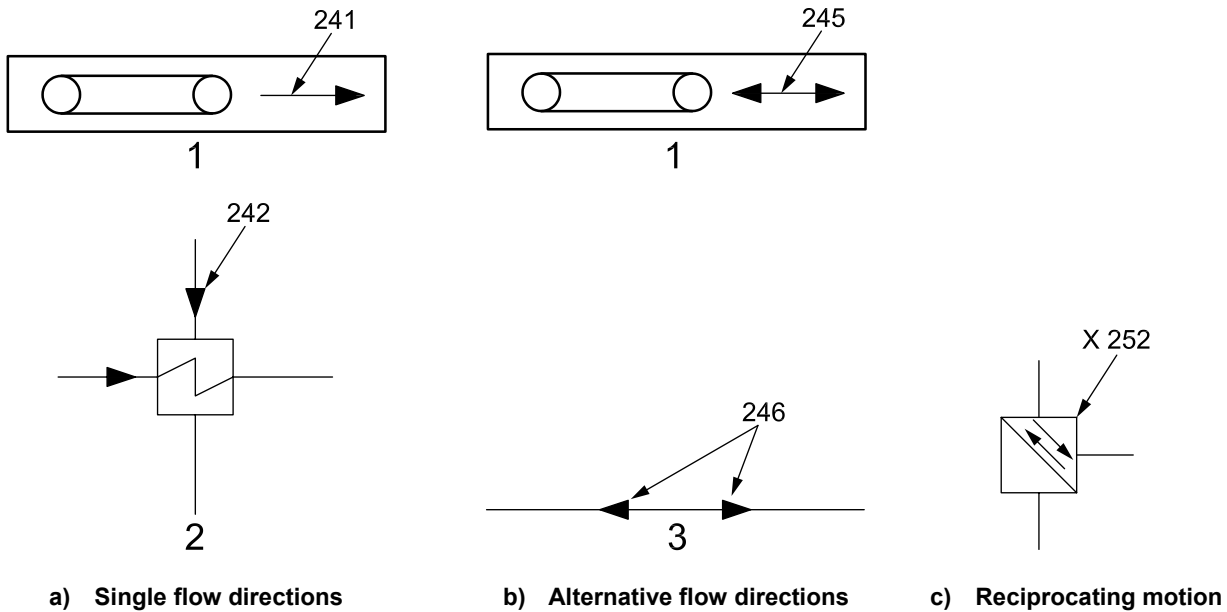

**Key**

- 1 belt conveyor
- 2 heat exchanger
- 3 pipeline

**Figure 23 — Example of symbol for mass flow and motion**

For indication of circular motion, symbol 255: *Circular motion* or symbol 256: *Circular motion, alternative directions*, shall be used. To indicate the rotation direction of a set of, for example, a motor and a pump, the symbol should only be placed at the driven unit. See, for example, Figure 24.

NOTE The following definitions apply for clockwise and anticlockwise rotation:

- clockwise rotation (CW): the component rotates clockwise when viewing at the shaft end.
- anticlockwise (CCW): the component rotates anticlockwise when viewing at the shaft end.

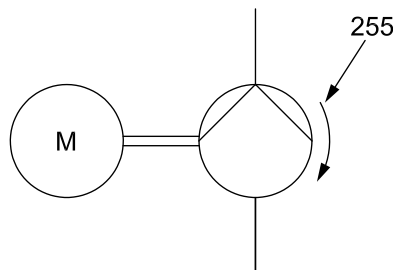

**Figure 24 — Example of clockwise indication**

For indication of propagation, for example energy or signals, symbol 249: *Propagation, energy or signal flow (simplex)*, shall be used. In the case of alternative directions, symbol 250: *Propagation, energy or signal flow,*

alternative directions (half-duplex) or simultaneously in both directions, symbol 251: *Propagation, energy or signal flow simultaneously in both directions (full-duplex)*, shall be used. See Figure 25.

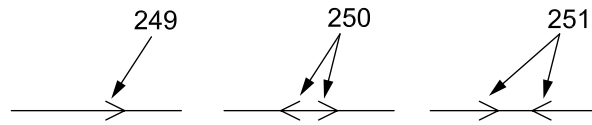

Figure 25 — Examples of symbols for propagation

For indication of working direction of fluid power, symbol 243: *Working direction of hydraulic power* and symbol 244: *Working direction of pneumatic power*, shall be used. The use of these symbols means that the direction of the fluid flow is according to the arrow in the active phase of the fluid. See examples in Figure 26 a) and b).

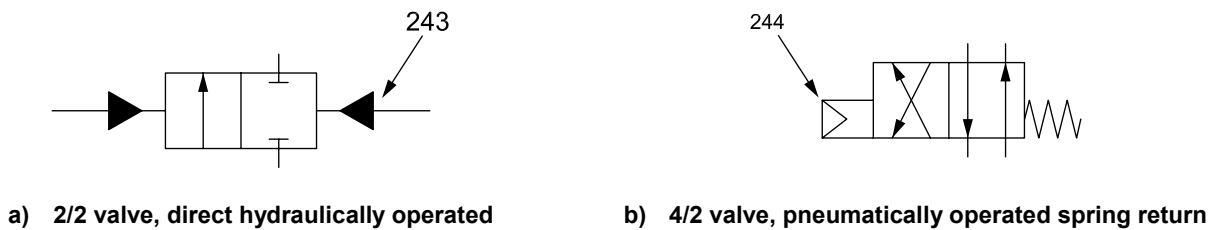

Figure 26 — Examples of fluid power valves

11.4.4 Correlation indication

To indicate a correlation between the movement or condition of two or more parts of a component, device or connections, the correlation symbol 263: *Correlation indication*, shall be used. See Figure 27 a) and b).

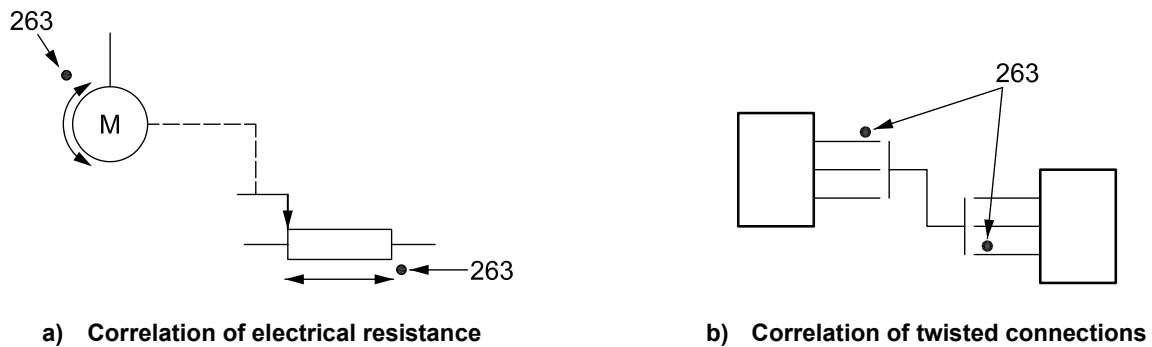

Figure 27 — Correlation

11.4.5 Indication of operational state of valves

If needed in diagrams to indicate the operational state of manual on-off valves – open or closed – then the required state may be indicated by adding the letter symbol NC *Normal closed* or NO *Normal open* above the symbol and to the right, as indicated in Figure 28, showing a normal closed on-off valve.

Such marking is especially relevant in diagrams in operation manuals to indicate different operational states of the system.



Figure 28 — Indication of operational state of manual on-off valves

## 12 Connections

### 12.1 General

For diagrams other than those with a topographical layout, the connecting lines representing pipelines, mechanical links, conductors, functional connections, etc., shall be straight with a minimum of bends and crossovers. Connecting lines shall be oriented horizontally or vertically, except in those cases where oblique lines improve the clarity of the diagram.

### 12.2 Significant connections

To emphasise or distinguish significant connections, wider lines shall be used. The line width shall be chosen according to the rules laid down in 6.2 and 6.3.

### 12.3 Simplified representation

To simplify and improve legibility of diagrams with parallel connecting lines between objects, such line bundles may be simplified and represented by one line. The number of represented lines shall be illustrated with symbols 341 to 344. Figure 29 a) shows two methods to illustrate a simplified connecting line representing three connecting lines by using symbols 343: *Three identical items* and 344: *Two or more identical items*.

Transition between multi-line and simplified single-line representation shall be done by using symbol 602: *Transition between multi-line and single-line representation*. See Figure 29 b)

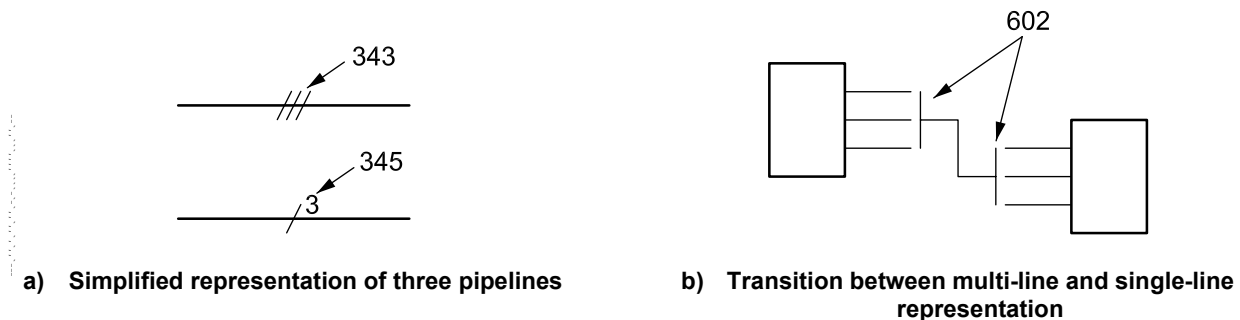

Figure 29 — Examples of simplification of line bundles

### 12.4 Joints

Joining of connecting lines shall be shown meeting or intersecting at right angles.

Joining shall be indicated with symbol 501: *Joint of connections*, a dot. See Figure 30 a) and c). The diameter of the dot shall be at least five times the width of the widest line, according to R501. In T-joint the dot may be omitted. See Figure 30 b).

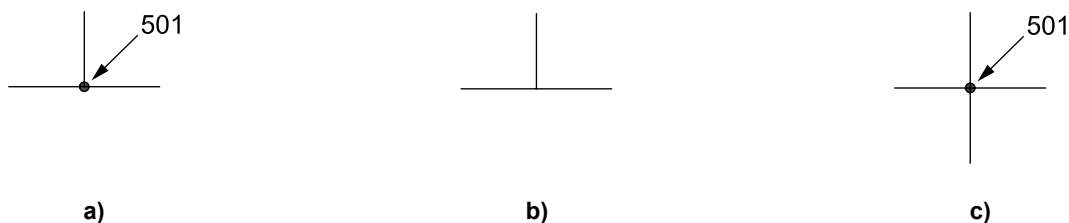
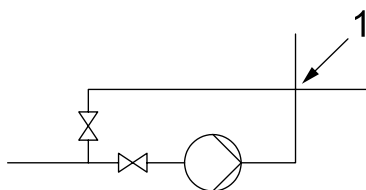

Figure 30 — Joining of connecting lines



## 12.5 Intersections

Intersection of connecting lines shall be shown as illustrated in Figure 31.



### Key

1 intersection without connection

**Figure 31 — Intersection of connecting lines**

## 12.6 References for interrupted connecting lines

When a connecting line continues on another sheet of a diagram, the ends shall be mutually referenced. The reference shall consist of an identification, as stated in Clause 9.

The references of each interrupted connecting line shall be unique and shall be placed in prolongation of connecting lines. See examples in Figure 32.

The connecting line references shall be placed in the outer grid zone of the content area in order to ease navigation between documents.

In cases of interruption of parallel connecting lines or bundles, the simplified representation principle, as illustrated in Figure 29 a), may be used. Each connecting line shall be identified.

In cases of two or more lines in the same zone, a line reference shall be added.

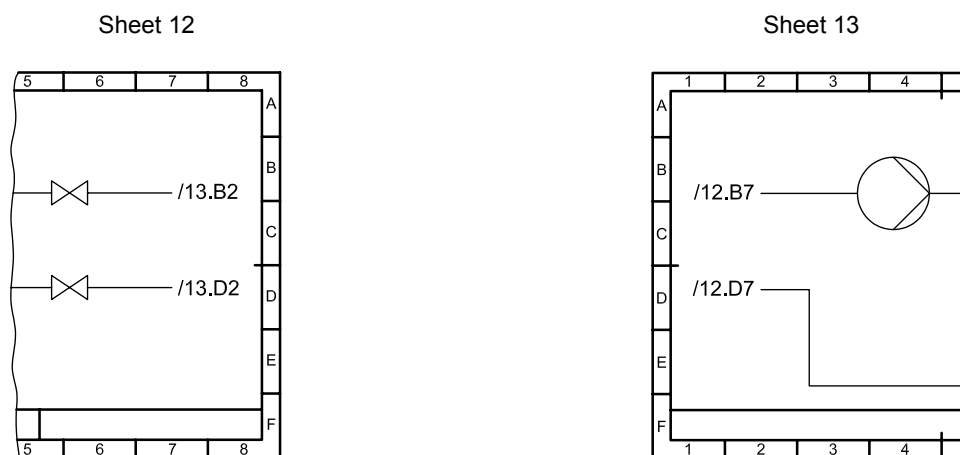

**Figure 32 — Interrupted connecting lines**

## 12.7 Objects with two or more system connections

Objects with two system connections, for example a heat exchanger, should only be shown in the diagram where its reference designation has been assigned. See Figure 33 a) showing a heat exchanger belonging to the main process. The cooling water connections, including diagram references, are shown with dotted lines in the process diagram. In the cooling water diagram the heat exchanger is shown with dotted connections and diagram references, as the heat exchanger does not belong to the cooling water system. See Figure 33 b).

When possible, the reference symbols should be placed in the outer rows and columns in the sheet in order to improve overview.

The symbol for connection reference is given in Annex A.

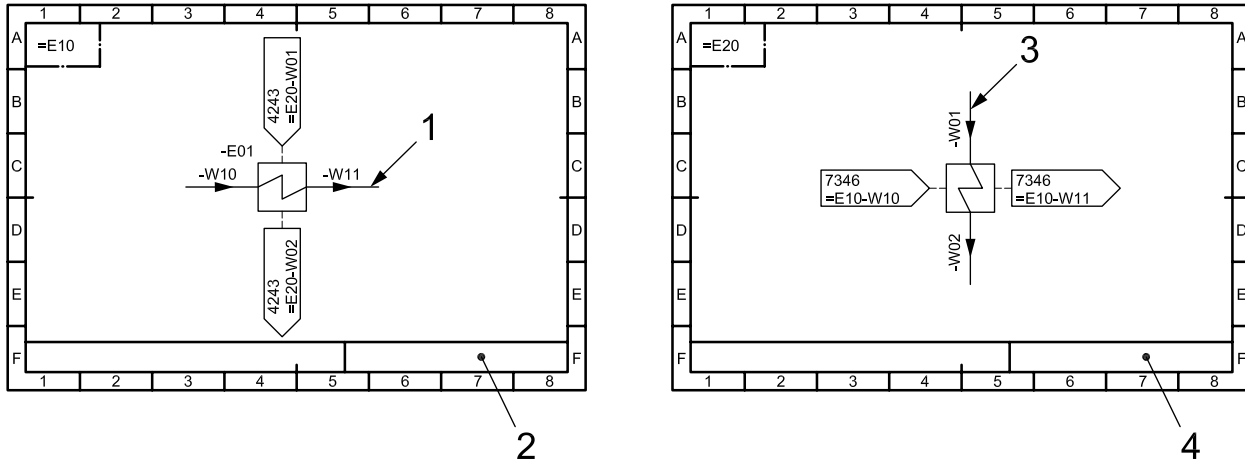

a) Process diagram

b) Cooling water diagram

**Key**

- 1 process
- 2 lubricating oil system: Doc.7348
- 3 cooling water
- 4 cooling water system: Doc.4243

**Figure 33 — Example of object with two or more system connections**

**13 Layout of diagrams**

**13.1 General aspect**

The most important consideration in the preparation of a flow diagram is the adoption of a clear layout that facilitates understanding. The symbols and circuits should be arranged in order to emphasise either functional relationship or physical location (topographical location) depending on the type of diagram.

In both cases, the objects or group of objects represented by means of graphical symbols in a diagram may be arranged as a horizontal or a vertical view, or a combination. With such equipment, where the gravity is an essential or important function, for example in a chemical process, the vertical view principle should be used.

For equipment consisting of tooling machines with horizontal conveyors in between, the horizontal view principle should be used.

**13.2 Functional layout**

When functional layout is used, the direction of the main flow should be from left to right or from top to bottom.

If the process equipment is located on an area in the form of a rectangle or another type of polygon, the layout of the flow diagram should, through this fact, be prepared as if the process equipment units were located in one line. See Figure 34.

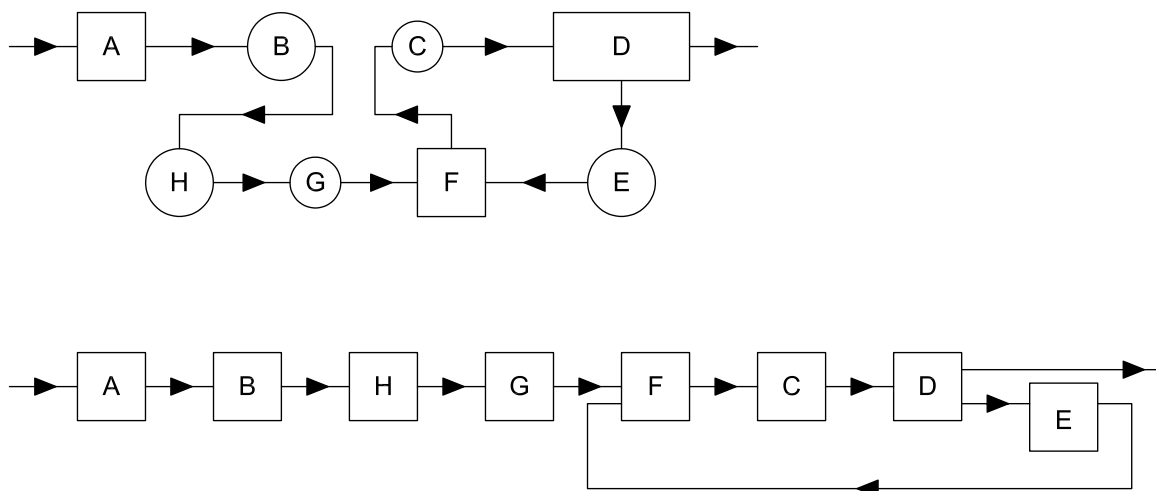

**Figure 34 — Layout of diagram for a “stretched out” process plant**

In some cases, for example in a workshop with several machine tools interlinked by a network of horizontal conveyors, it may be better to prepare the flow diagram as if the plant were looked upon from above. See Figure 35, which illustrates horizontal layout of a workshop with several workshop machines interlinked by roller conveyors.

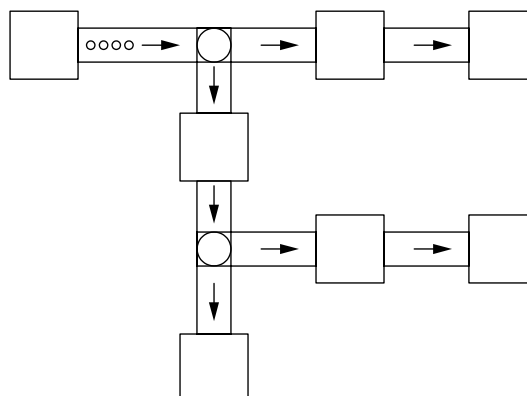

**Figure 35 — “Horizontal layout” of a workshop**

In a diagram representing a control system, the function-oriented groups forming the controlling system should be placed to the left of or above the function-oriented groups that represent the controlled system. See Figure 36.

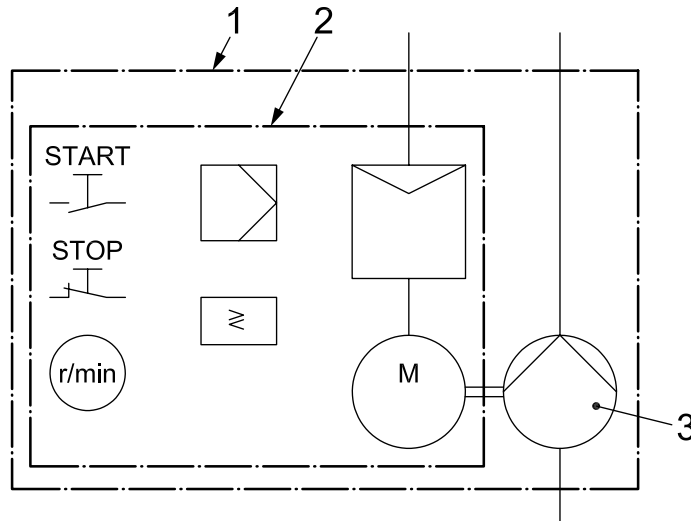

- Key**
- 1 control system
  - 2 controlling system
  - 3 controlled system/object

**Figure 36 — Diagram layout of a control system**

### 13.3 Topographical layout

In a diagram with a topographical layout, the symbols should be grouped and placed to show the relative positions of the corresponding components. This method is primarily used for network maps.

When necessary, the location shall be determined in more detail. For that purpose, the designations shall be defined in a suitable manner.

## 14 Types of diagram

### 14.1 General

Diagrams for the process industry are divided into two main types, overview diagrams and function diagrams.

The objective with an overview diagram is to give information of a plant or system on a superior level. Thus, the overview diagram serves both to give information of “overviewing” character and to function as a key or index to the more detailed information in the form of function diagrams.

The objective with a function diagram is to give detailed information about the functional configuration of a system or object, reference designation for the same system or object and connections to other systems or objects. Thus, the function diagram serves both to give detailed information about the presented system or object and to function as key or index to other information by means of applied reference designations and connection references.

Annex B provides information about different types of overview diagrams and function diagrams and recommendations for minimum content in the form of basic information and additional content in the form of optional information.

### 14.2 Overview diagrams

An overview diagram provides an overall view of a system or an object with a low degree of detailing, for example only showing the main object, using the single-line presentation technique, etc. Detailed information

concerning the presented main objects should be given in more detailed diagram types, for example function diagrams.

An overview diagram may also include electrotechnical objects.

Multi-line connections should be presented using single line presentation, for example: district heating supply and return pipes should only be represented by one line in network maps.

Figures 37 and 38 show examples of different types of overview diagrams.

### 14.3 Function diagrams

A function diagram provides information about the functional behaviour of a system or an object. The diagram shall present the systems or objects and their interconnections, independent of physical implementation.

When necessary for interpretation, function diagrams should include electrotechnical objects, for example electrical motors and instrumentation, and also measuring objects, for example measuring instruments, simplified control loops, actuators, etc.

Function diagrams may include presentation of sequential steps in a process, for example in a coal mining and coal preparation plant as described in ISO 924.

Figures 39 and 40 show examples of different types of function diagrams.

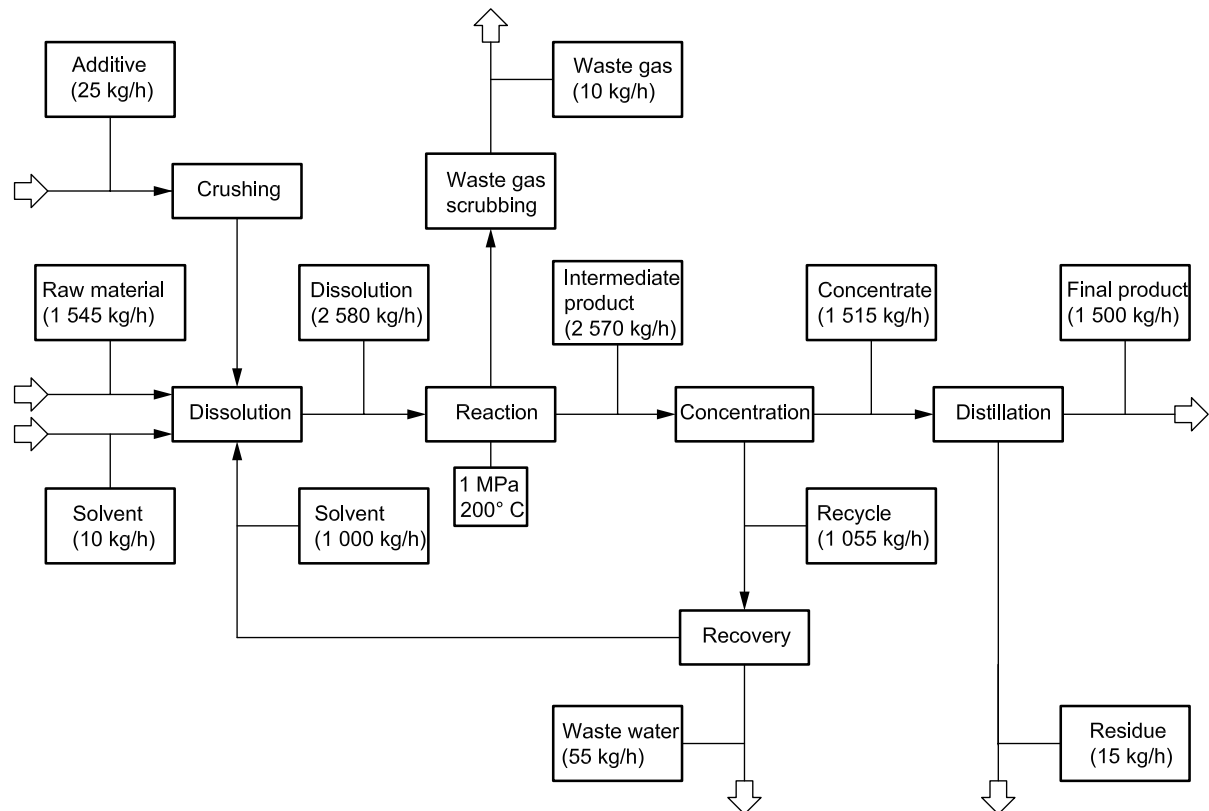
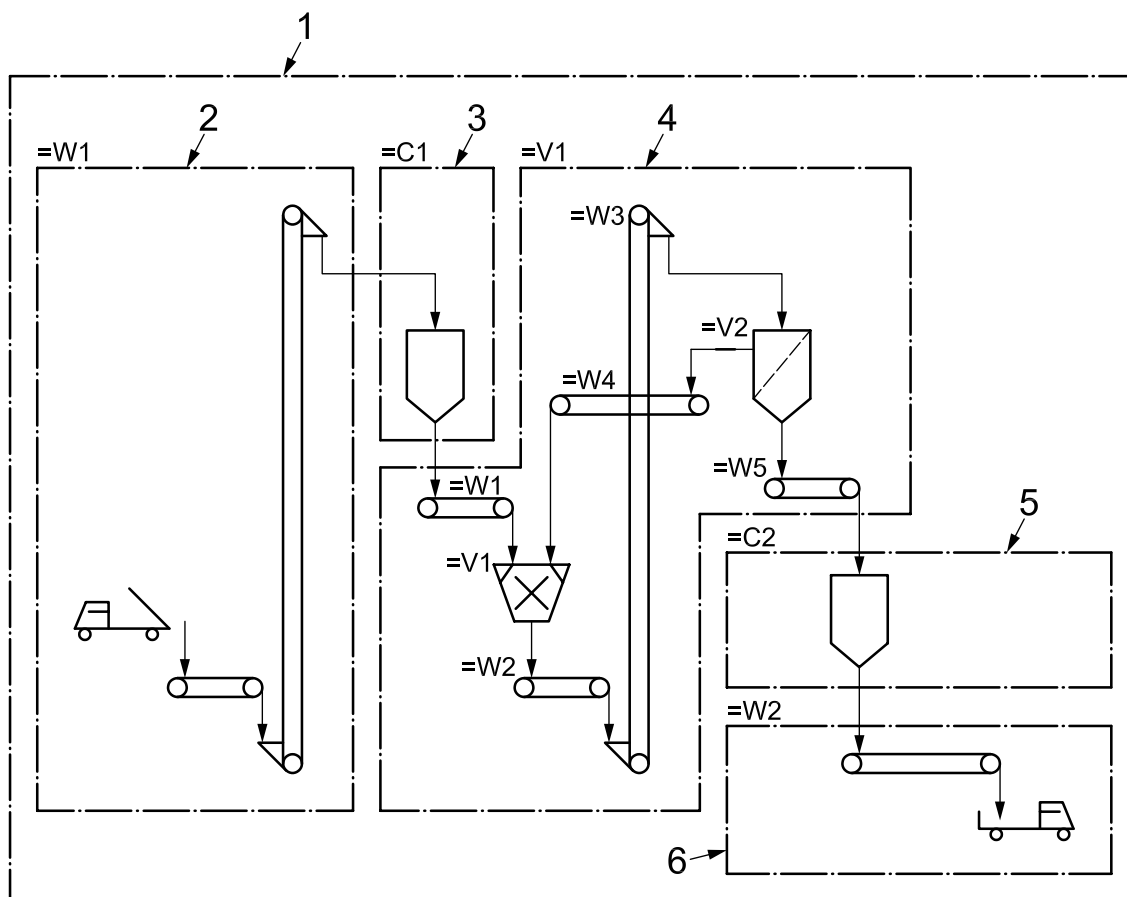

Figure 37 — Overview diagram of process system using block symbols (block diagram)



**Key**

- 1 material handling plant
- 2 receiving system
- 3 receiving storage system
- 4 processing system
- 5 processing storage system
- 6 loading system

**Figure 38 — Overview diagram for a material processing plant**

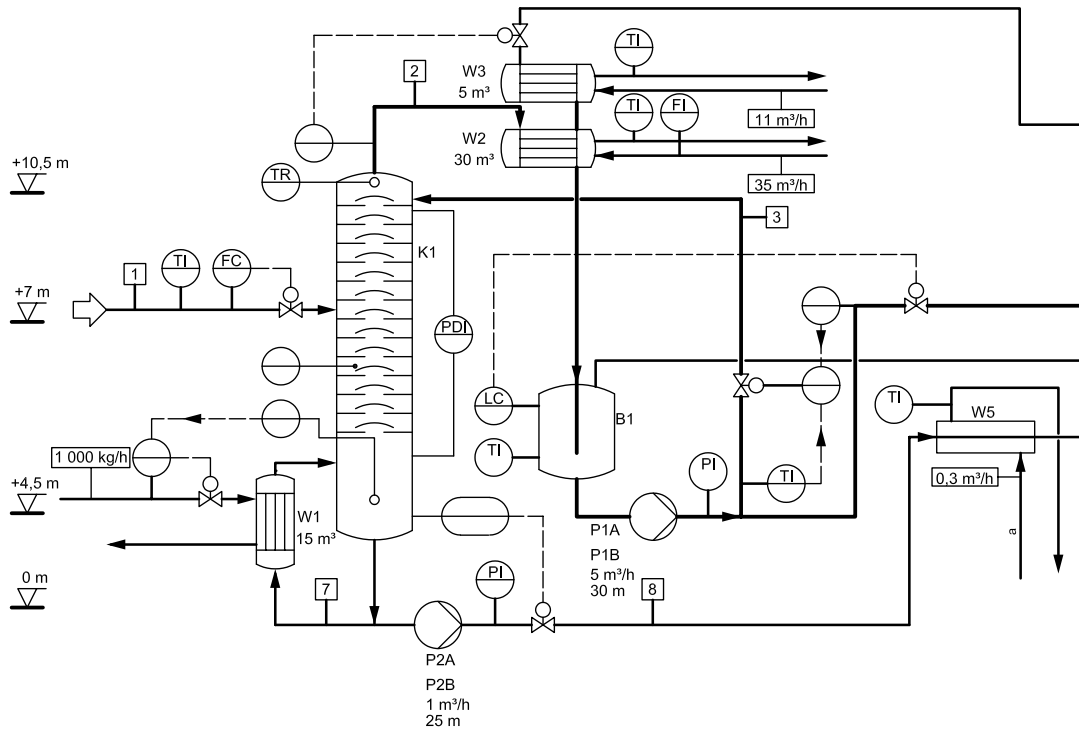

a Cooling water.

Figure 39 — Function diagram for a petrochemical system

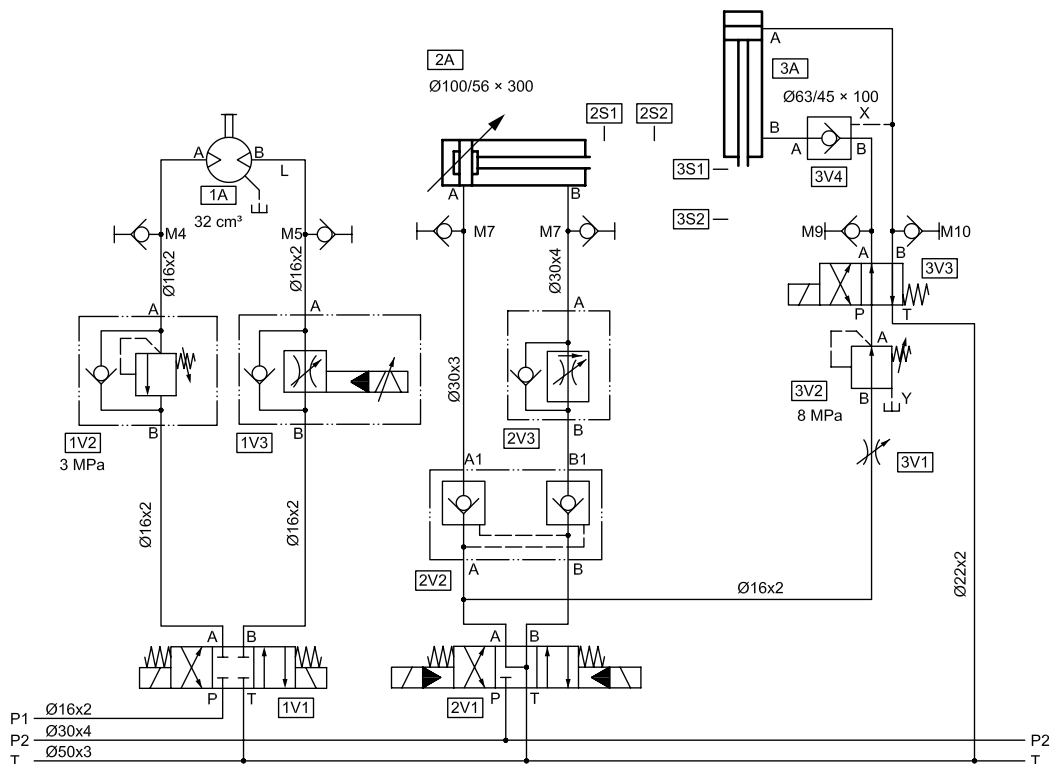

Figure 40 — Function diagram from a fluid power system

## Annex A (informative)

### Diagram symbols

1		<p>Limit of supply</p> <p>Information, for example of suppliers, should be placed on either side of the upper part of the symbol, as indicated</p>
2		<p>Connection reference</p> <p>Reference information should be placed in two lines within the symbol</p> <p>Upper line    Reference to document</p> <p>Lower line    Reference to reference designation for connection</p>

Copyright International Organization for Standardization  
 Provided by IHS under license with ISO  
 No reproduction or networking permitted without license from IHS



## Annex B (informative)

### Document type designation and content of information

This annex gives more specific information about the content of diagrams. Further, it also lists diagrams commonly used for documentation of industrial processes.

Table B.1 deals with diagram types and their content divided into basic information and optional information.

Tables B.2 and B.3 describe different types of diagram commonly used for documentation of industrial processes.

**Table B.1 — Recommended document type designations and contents**

Document type designation	Description and content of information
Overview diagram	<p>Diagram providing a comprehensive view of an object with low degree of detailing</p> <p><u>Basic information</u></p> <ul style="list-style-type: none"> <li>• graphical symbols representing the objects</li> <li>• main interrelations and connections</li> <li>• designations and references to more detailed documents</li> </ul> <p><u>Optional information</u></p> <ul style="list-style-type: none"> <li>• location information, for example maps</li> <li>• reference designations for main objects</li> <li>• explanatory information</li> </ul>
Function diagram	<p>Diagram providing information about the functional behaviour of a system</p> <p><u>Basic information</u></p> <ul style="list-style-type: none"> <li>• graphical symbols for objects representing functions and products</li> <li>• graphical symbols representing connections and interrelations</li> <li>• reference designations for represented objects</li> <li>• technical information</li> </ul> <p><u>Optional information</u></p> <ul style="list-style-type: none"> <li>• port designations</li> <li>• supplementary technical information</li> <li>• explanatory information</li> </ul>

**Table B.2 — Types of overview diagram**

Network map	Overview diagram showing a network on a map, for example district heating system, natural gas distribution system.
Block diagram	Overview diagram predominately using block symbols.

**Table B.3 — Types of function diagram**

Process flow diagram	Function diagram illustrating the configuration of a process system or process plant by means of graphical symbols.
Piping and instrumentation diagram	Process flow diagram representing the technical realization of a process system by means of graphical symbols for equipment, connections and process measurement and control functions.

.....

## Bibliography

- [1] ISO 129-1, *Technical drawings — Indication of dimensions and tolerances — Part 1: General principles*
- [2] ISO 3864-1, *Graphical symbols — Safety colours and safety signs — Part 1: Design principles for safety signs and safety markings*
- [3] ISO 5127:2001, *Information and documentation — Vocabulary*
- [4] ISO 5598, *Fluid power systems and components — Vocabulary*
- [5] ISO/IEC 8613-1:1994, *Information technology — Open Document Architecture (ODA) and interchange format: Introduction and general principles — Part 1*
- [6] ISO 10209-1:1992, *Technical product documentation — Vocabulary — Part 1: Terms relating to technical drawings: general and types of drawings*
- [7] ISO 10628:1997, *Flow diagrams for process plants — General rules*
- [8] ISO 11442, *Technical product documentation — Document management*
- [9] ISO 15226, *Technical product documentation — Life cycle model and allocation of documents*
- [10] IEC 60073, *Basic and safety principles for man-machine interface, marking and identification — Coding principles for indicators and actuators*
- [11] IEC 60204-1, *Safety of machinery — Electrical equipment of machines — Part 1: General requirements*
- [12] IEC 61082-1:2006, *Preparation of documents used in electrotechnology — Part 1: Rules*
- [13] IEC 62023:2000, *Structuring of technical information and documentation*
- [14] IEC 62027, *Preparation of parts lists*
- [15] IEC 82045-1, *Document management — Part 1: Principles and methods*

The following International Standards contain rules for diagrams for industrial application

- [16] ISO 924, *Coal preparation plant — Principles and conventions for flowsheets*
- [17] ISO 1219-2, *Fluid power systems and components — Graphic symbols and circuit diagrams — Part 2: Circuit diagrams*

15519-1:2010

---

---

**ICS 01.080.30; 01.110**

Price based on 37 pages