



INTERNATIONAL STANDARD ISO 15502:2005
TECHNICAL CORRIGENDUM 1

Published 2007-02-15

INTERNATIONAL ORGANIZATION FOR STANDARDIZATION • МЕЖДУНАРОДНАЯ ОРГАНИЗАЦИЯ ПО СТАНДАРТИЗАЦИИ • ORGANISATION INTERNATIONALE DE NORMALISATION

Household refrigerating appliances — Characteristics and test methods

TECHNICAL CORRIGENDUM 1

Technical Corrigendum 1 to ISO 15502:2005 was prepared by Technical Committee ISO/TC 86, *Refrigeration and air-conditioning*, Subcommittee SC 5, *Testing and rating of household refrigeration appliances*.

Page 1, Normative references

Date and correct the reference to IEC 60335-2-24 by replacing it with the following:

IEC 60335-2-24:2006, *Household and similar electrical appliances — Safety — Part 2-24: Particular requirements for refrigerating appliances, ice-cream appliances and ice-makers*

Delete the footnote.

Page 56, Note to Figure 15

Replace the Note with the following, thereby deleting an incorrect cross-reference to Figure 13:

NOTE The arrangements for cellar compartments also apply to appliances that consist only of a cellar compartment. For different evaporator arrangements in the fresh-food compartment, see also Figure 14.

Page 59, Figure 17

Add “Dimensions in millimetres” to the top right-hand corner of the figure.

Pages 65 and 66, Figures 18 and 19

Replace Figures 18 and 19 with the following, whose legends have been corrected and to which captions have been added.

ICS 97.040.30

Ref. No. ISO 15502:2005/Cor.1:2007(E)

© ISO 2007 – All rights reserved

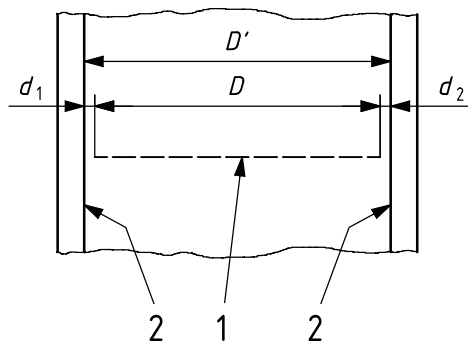

a) Determination of width of shelf

If $d_1 + d_2 \leq 20$ mm:

dimension of shelf = D'

If $d_1 + d_2 > 20$ mm:

dimension of shelf = D

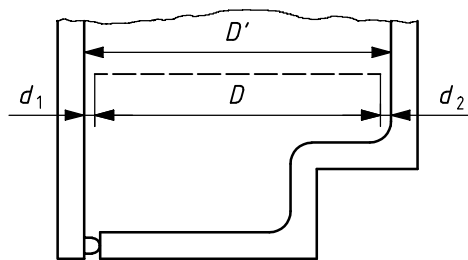

b) Determination of depth of shelf

If $d_1 + d_2 \leq 20$ mm:

dimension of shelf = D'

If $d_1 + d_2 > 20$ mm:

dimension of shelf = D

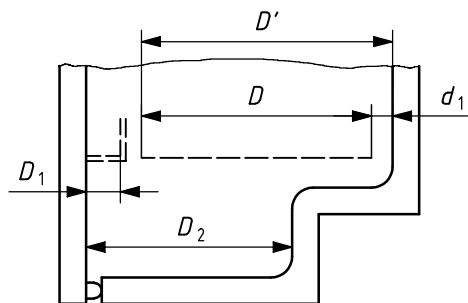

c) Determination of depth of shelf of upright-type refrigerating appliance

If $d_1 \leq 20$ mm:

dimension of shelf = D'

If $d_1 > 20$ mm:

dimension of shelf = D

D_1 dimension of door shelf

D_2 dimension of bottom of refrigerating appliance

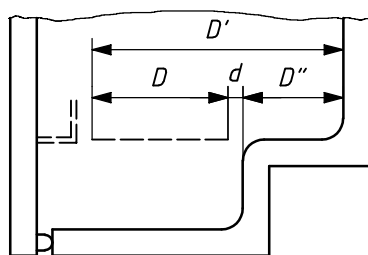

d) Determination of depth of shelf with juxtaposed parts

If $d \leq 20$ mm:

dimension of shelf = D'

If $d > 20$ mm:

two shelves of dimensions D and D''

Figure 18 — Examples of determination of dimensions for calculating shelf area (see 7.3)

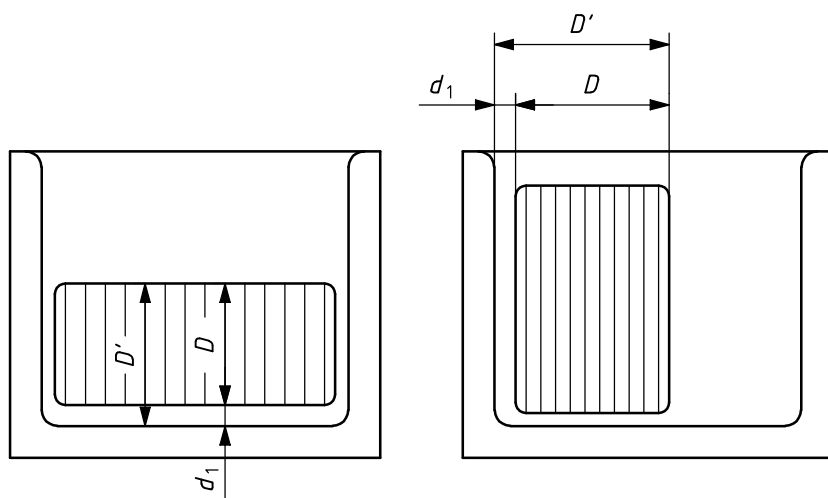

If $d_1 \leq 20$ mm:
 dimension of shelf = D'
 If $d_1 > 20$ mm:
 dimension of shelf = D

e) Determination of width and depth of fractional shelves

Key

- 1 shelf
- 2 inner wall

Figure 18 — Examples of determination of dimensions for calculating shelf area (see 7.3) (continued)

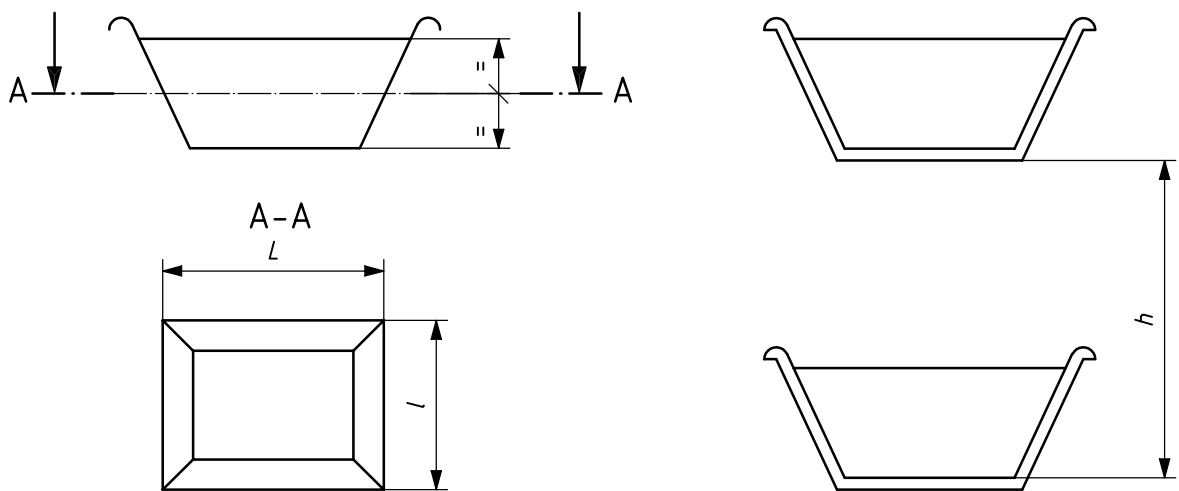

a) Area of basket

b) Vertical clearance above basket

$h \geq 80$ mm

$h \geq 52$ mm for any frozen-food storage compartment

Figure 19 — Examples of determination of mean dimensions for calculating basket area (see 7.3.2.6, 7.3.2.7.2 and 7.3.2.7.3)

ISO 15502:2005/Cor.1:2007(E)

Page 74, Annex B, B.1

In the definition of *D* given after the formula, correct the cross-reference to the subclause from 3.6.21 to 3.6.20.

Page 81, Bibliography

Change the date of Reference [3] from 1989 to 2004.

Correct the title of Reference [4] to *Household and similar electrical appliances — Safety — Part 1: General requirements*.

.....

INTERNATIONAL STANDARD

ISO 15502

First edition
2005-10-15

Household refrigerating appliances — Characteristics and test methods

*Appareils de réfrigération à usage ménager — Caractéristiques et
méthodes d'essai*

15502



Reference number
ISO 15502:2005(E)

© ISO 2005

PDF disclaimer

This PDF file may contain embedded typefaces. In accordance with Adobe's licensing policy, this file may be printed or viewed but shall not be edited unless the typefaces which are embedded are licensed to and installed on the computer performing the editing. In downloading this file, parties accept therein the responsibility of not infringing Adobe's licensing policy. The ISO Central Secretariat accepts no liability in this area.

Adobe is a trademark of Adobe Systems Incorporated.

Details of the software products used to create this PDF file can be found in the General Info relative to the file; the PDF-creation parameters were optimized for printing. Every care has been taken to ensure that the file is suitable for use by ISO member bodies. In the unlikely event that a problem relating to it is found, please inform the Central Secretariat at the address given below.

© ISO 2005

All rights reserved. Unless otherwise specified, no part of this publication may be reproduced or utilized in any form or by any means, electronic or mechanical, including photocopying and microfilm, without permission in writing from either ISO at the address below or ISO's member body in the country of the requester.

ISO copyright office
Case postale 56 • CH-1211 Geneva 20
Tel. + 41 22 749 01 11
Fax + 41 22 749 09 47
E-mail copyright@iso.org
Web www.iso.org

Published in Switzerland

Contents

Page

Foreword.....	iv
1 Scope	1
2 Normative references	1
3 Terms, definitions and symbols	1
4 Classification.....	8
5 Materials, design and manufacture.....	8
6 Storage temperatures.....	10
7 Determination of linear dimensions, volumes and areas	12
8 General test conditions	18
9 Testing air-tightness of doors, lids or drawer seals	25
10 Testing opening force of doors or lids	25
11 Testing the durability of doors, lids and drawers	25
12 Testing mechanical strength of shelves and similar components.....	28
13 Testing storage temperatures	29
14 Water vapour condensation test.....	33
15 Energy consumption test.....	34
16 Temperature rise test	39
17 Freezing test.....	40
18 Ice-making test.....	44
19 Final test report.....	47
20 Designation	47
21 Marking	48
22 Technical and commercial product information	50
23 Instructions for users	51
Annex A (informative) Conditions particular to certain countries	72
Annex B (informative) Percentage running time	74
Annex C (informative) Test for absence of taste and odour	75
Annex D (normative) Built-in refrigerating appliances.....	78
Annex E (informative) Rated characteristics and control procedure	79
Bibliography	81

Foreword

ISO (the International Organization for Standardization) is a worldwide federation of national standards bodies (ISO member bodies). The work of preparing International Standards is normally carried out through ISO technical committees. Each member body interested in a subject for which a technical committee has been established has the right to be represented on that committee. International organizations, governmental and non-governmental, in liaison with ISO, also take part in the work. ISO collaborates closely with the International Electrotechnical Commission (IEC) on all matters of electrotechnical standardization.

International Standards are drafted in accordance with the rules given in the ISO/IEC Directives, Part 2.

The main task of technical committees is to prepare International Standards. Draft International Standards adopted by the technical committees are circulated to the member bodies for voting. Publication as an International Standard requires approval by at least 75 % of the member bodies casting a vote.

Attention is drawn to the possibility that some of the elements of this document may be the subject of patent rights. ISO shall not be held responsible for identifying any or all such patent rights.

ISO 15502 was prepared by Technical Committee ISO/TC 86, *Refrigeration and air-conditioning*, Subcommittee SC 5, *Testing and rating of household refrigeration appliances*.

This first edition cancels and replaces ISO 5155:1995, ISO 7371:1995, ISO 8187:1991 and ISO 8561:1995, of which it constitutes a technical revision. It also incorporates the amendments ISO 7371:1995/Amd.1:1997, ISO 8187:1991/Amd.1:1997 and ISO 8561:1995/Amd.1:1997.

Household refrigerating appliances — Characteristics and test methods

1 Scope

This International Standard specifies the essential characteristics of household refrigerating appliances, factory-assembled and cooled by internal natural convection or forced air circulation, and establishes test methods for checking the characteristics. These are type tests, and because of this, when verification of the performance of a refrigerating appliance of a given type in relation to this International Standard is necessary, it is preferable, wherever practicable, that all the tests specified be applied to a single unit. The tests can also be made individually for the study of a particular characteristic.

NOTE For the safety requirements applicable to household refrigerating appliances, see IEC 60335-2-24, for noise requirements applicable to household refrigerators and freezers, see ISO 8960, and for additional safety requirements applicable to the refrigerating systems of household refrigerating appliances, see in ISO 5149.

2 Normative references

The following referenced documents are indispensable for the application of this document. For dated references, only the edition cited applies. For undated references, the latest edition of the referenced document (including any amendments) applies.

ISO 534, *Paper and board — Determination of thickness, density and specific volume*

ISO 817, *Refrigerants — Designation system*

ISO 8960, *Refrigerators, frozen-food storage cabinets and food freezers for household and similar use — Measurement of emission of airborne acoustical noise*

IEC 60335-2-24:—¹⁾, *Household and similar electrical appliances — Safety — Part 2-24: Particular requirements for refrigerating appliances, ice-cream appliances and icemakers*

3 Terms, definitions and symbols

For the purposes of this document, the following terms, definitions and symbols apply.

3.1

refrigerating appliance

factory-assembled insulated cabinet with one or more compartments and of suitable volume and equipment for household use, cooled by natural convection or a frost-free system whereby the cooling is obtained by one or more energy-consuming means

NOTE From the point of view of installation, there are various types of household refrigerating appliance (free-standing, wall-mounted, built-in, etc.).

1) To be published. (Revision of IEC 60335-2-24:2002)

3.1.1

compression-type refrigerating appliance

refrigerating appliance in which refrigeration is effected by means of a motor-driven compressor

3.1.2

absorption-type refrigerating appliance

refrigerating appliance in which refrigeration is effected by an absorption process using heat as energy source

3.1.3

refrigerator

refrigerating appliance intended for the preservation of food, one of whose compartments is suitable for the storage of fresh food

3.1.3.1

frost-free refrigerator

refrigerator in which all compartments are automatically defrosted with automatic disposal of the defrosted water and at least one compartment is cooled by a frost-free system and at least one is a "frozen-food storage" compartment

NOTE A single-compartment refrigerator using a frost-free system cannot be called a frost-free refrigerator.

3.1.4

refrigerator-freezer

refrigerating appliance having at least one compartment suitable for the storage of fresh food (the fresh-food storage compartment) and at least one other (the food freezer compartment) suitable for the freezing of fresh food and the storage of frozen food under three-star storage conditions

3.1.4.1

frost-free refrigerator-freezer

refrigerator-freezer in which all compartments are automatically defrosted with automatic disposal of the defrosted water and at least one compartment is cooled by a frost-free system

3.1.5

frozen-food storage cabinet

refrigerating appliance having one or more compartments suitable for the storage of frozen food

3.1.5.1

frost-free frozen-food storage cabinet

frozen-food storage cabinet in which all compartments are automatically defrosted with automatic disposal of the defrosted water and which is cooled by a frost-free system

3.1.6

food freezer

refrigerating appliance having one or more compartments suitable for freezing foodstuffs from ambient temperature down to a temperature of $-18\text{ }^{\circ}\text{C}$ and which is also suitable for the storage of frozen food under three-star storage conditions

NOTE In certain instances, two-star sections and/or compartments are permitted within the compartment or cabinet (see 7.2.8).

3.1.6.1

frost-free food freezer

food freezer in which all compartments are automatically defrosted with automatic disposal of the defrosted water and at least one compartment is cooled by a frost-free system

3.1.7

built-in appliance

fixed refrigerating appliance intended to be installed in a cabinet, in a prepared recess in a wall or similar location

3.2**frost-free system**

system automatically operated to prevent the permanent formation of frost, in which cooling is provided by forced air circulation, the evaporator or evaporators are defrosted by an automatic defrost system and the water from defrosting is disposed of automatically

3.3 Compartments and sections**3.3.1****fresh-food storage compartment**

compartment intended for the storage of unfrozen food, which may itself be divided into sub-compartments

NOTE The storage temperatures can be maintained according to Clause 6.

3.3.2**cellar compartment**

compartment intended for the storage of particular foods or beverages at a temperature warmer than that of the fresh-food storage compartment

NOTE The storage temperatures can be maintained according to Clause 6.

3.3.3**chill compartment**

compartment intended specifically for the storage of highly perishable foodstuffs whose volume is capable of containing at least 2 M packages

NOTE The storage temperatures can be maintained according to Clause 6.

3.3.4**ice-making compartment**

low-temperature compartment intended specifically for the freezing and storage of ice

3.3.5**frozen-food storage compartment**

low-temperature compartment intended specifically for the storage of frozen food

NOTE Frozen-food storage compartments are classified according to temperature, see 3.3.5.1 to 3.3.5.5.

3.3.5.1**one-star compartment**

frozen-food storage compartment in which the temperature is not warmer than $-6\text{ }^{\circ}\text{C}$

3.3.5.2**two-star compartment**

frozen-food storage compartment in which the temperature is not warmer than $-12\text{ }^{\circ}\text{C}$

3.3.5.3**three-star compartment**

frozen-food storage compartment in which the temperature is not warmer than $-18\text{ }^{\circ}\text{C}$

3.3.5.4**food freezer compartment****four-star compartment**

compartment suitable for freezing foodstuffs from ambient temperature down to $-18\text{ }^{\circ}\text{C}$, and which is also suitable for the storage of frozen food under three-star storage conditions

NOTE Two-star sections and/or compartments are permitted within the compartment or cabinet (see 7.2.8).

3.3.5.5

two-star section

part of a food freezer compartment or cabinet, or three-star compartment or cabinet, which is not self-contained (i.e. does not have its own individual access door or lid) and in which the temperature is not warmer than $-12\text{ }^{\circ}\text{C}$

3.4

rated

stated as a value (e.g. a volume) by the manufacturer

3.5 Physical aspects and dimensions

3.5.1

top-opening type

refrigerating appliance in which the compartment(s) are accessible from the top

3.5.2

upright type

refrigerating appliance in which the compartment(s) are accessible from the front

3.5.3

overall dimensions

space — height, width and depth — with doors or lids closed taken up by the refrigerating appliance

3.5.4

overall space required in use

total space — height, width and depth — with doors or lids open necessary for the refrigerating appliance for normal use

3.5.5

gross volume

volume within the inside liner of the refrigerating appliance, or of a compartment with an external door, without internal fittings and with the doors or lids closed

3.5.6

storage volume

part of the gross volume of any compartment that remains after deduction of the volume of components and spaces recognized as unusable for the storage of food

NOTE See 7.2.

3.5.7

shelf

horizontal surface (shelves, partitions, etc.) on which food can be placed

NOTE It can be formed by one component or by components fitted side by side, which can be fixed or removable.

3.5.8

storage shelf area

sum of the horizontal projections of the storage surfaces within the storage volume, including door shelves and the bottom of each compartment

NOTE See 7.3.

3.5.9

load limit

surface enveloping a frozen-food storage volume

3.5.10**load-limit line**

permanent mark indicating limit of three-star frozen-food storage volume

3.5.11**storage plan**

arrangement of test packages within a refrigerating appliance

3.6 Definitions relating to performance characteristics**3.6.1****energy consumption**

energy consumed by a refrigerating appliance calculated over a period of 24 h when tested according to this International Standard

3.6.2**fresh-food storage temperature**

t_{ma}

mean temperature of the fresh-food storage compartment

3.6.3**frozen-food storage temperature**

t^* , t^{**} , t^{***}

maximum temperature of any M package during the test period

NOTE 1 The superscript attached to the symbol t corresponds to the one-star, two-star or three-star temperature.

NOTE 2 See 8.8.3.

3.6.4**cellar compartment storage temperature**

t_{cma}

mean temperature of the cellar compartment

3.6.5**chill compartment storage temperature**

t_{cc}

instantaneous storage temperature of the chill compartment

3.6.6**freezing capacity**

amount of food expressed in kilograms that can be frozen to a temperature of $-18\text{ }^{\circ}\text{C}$ in 24 h when tested in accordance with Clause 17 of this International Standard

3.6.7**ice-making capacity**

quantity of ice the refrigerating appliance is capable of producing within 24 h in an automatic icemaker, and/or the time necessary for the freezing of the water in the ice tray(s) supplied with the refrigerating appliance

3.6.8**automatic defrost**

defrosting where no action is necessary by the user to initiate the removal of frost accumulation or to restore normal operation, and the disposal of the defrost water is automatic

3.6.9

semi-automatic defrost

defrosting where an action is necessary by the user to initiate the removal of frost accumulation and normal operation is restored automatically, the defrost water being removed manually or removed and disposed of automatically

3.6.10

semi-automatic defrost

defrosting where no action is necessary by the user to initiate the removal of frost accumulation nor to restore normal operation, but the removal of the defrost water is manual

3.6.11

manual defrost

defrosting where an action is necessary by the user to initiate the removal of frost accumulation and where restoration to normal operation requires a further action by the user, the defrost water being removed manually or removed and disposed of automatically

3.6.12

automatic disposal of defrost water

removal and evaporation of the defrost water which does not require any action by the user

3.6.13

manual removal of defrost water

collection and removal of defrost water that requires actions by the user

3.6.14

adaptive defrost

form of automatic defrosting system where energy consumed in defrosting is reduced by an automatic process whereby the time intervals between successive defrosts are determined by an operating condition variable (or variables) other than, or in addition to, elapsed time or compressor run time.

3.6.15

test package

food simulant used as load when testing frozen food compartments and chill compartments and during freezing capacity testing in all compartments of refrigerator-freezers

3.6.16

M-package

test package fitted with a temperature sensor at its geometric centre

3.6.17

operating cycle

<frost-free systems> period commencing at the initiation of an automatic defrosting cycle and terminating at the moment of initiation of the next automatic defrosting cycle

3.6.18

operating cycle

<systems designed to operate continuously> period of 24 h under stable operating conditions

3.6.19

operating cycle

<other refrigerating appliances> period between two successive stops of the refrigerating system, or part of the system, under stable operating conditions

3.6.20

automatic defrosting cycle

period between the moment when the means of defrosting the evaporator(s) is switched on and the moment when the refrigeration process is re-established

3.6.21**stable operating conditions**

conditions in which a refrigerating appliance's mean temperatures and energy consumption are stable

3.6.22**ambient temperature**

measured temperature in the space surrounding the refrigerating appliance under test

3.6.23**temperature rise time**

time period needed to raise the temperature of food in the frozen food compartment from -18 °C to -9 °C after the operation of the refrigerated system has been interrupted

3.7 Definitions relating to refrigerating system**3.7.1****refrigerant**

fluid used for heat transfer in a refrigerating system, which absorbs heat at a low temperature and at a low pressure of the fluid and rejects heat at a higher temperature and at a higher pressure of the fluid, usually involving changes of state of the fluid

3.7.2**condenser**

heat exchanger in which vaporized refrigerant is liquefied by rejecting heat to an external cooling medium

3.7.3**evaporator**

heat exchanger in which the liquid refrigerant is vaporized by absorbing heat from the medium to be refrigerated

3.7.4**temperature control device**

device which automatically regulates the operation of a refrigerating system according to the temperature of an evaporator or of a compartment or cabinet

3.8 Symbols

T_i, T_{ci}	temperature measurement points
t_i	instantaneous temperature value (fresh food compartment)
t_{ci}	instantaneous temperature value (cellar compartment)
t_{cc}	instantaneous temperature value (chill compartment)
t_{im}	integrated time average of t_i
t_{cim}	integrated time average of t_{ci}
t_a	instantaneous arithmetic average of t_1, t_2, t_3
t_{ca}	instantaneous arithmetic average of t_{c1}, t_{c2}, t_{c3}
t_{ma}	arithmetic average of t_{1m}, t_{2m}, t_{3m}
t_{cma}	arithmetic average of $t_{c1m}, t_{c2m}, t_{c3m}$
i	subscript representing 1, 2 or 3

4 Classification

4.1 Refrigerating appliances conforming to this International Standard are classified into four climate classes or into a range of classes, see Table 1. The range of ambient temperatures in which the appliances are intended to be used, and for which the required storage temperatures are to be met (see Clause 6), shall be as specified in Table 1.

Table 1 — Climate classes

Class	Symbol	Ambient temperature range °C
Extended temperate	SN	+ 10 to + 32
Temperate	N	+ 16 to + 32
Subtropical	ST	+ 16 to + 38
Tropical	T	+ 16 to + 43

4.2 Refrigerator-freezers conforming to this International Standard are classified into the following two types:

- a) refrigerator-freezer type I — having a single, user-adjustable temperature control device for regulating the temperatures of the fresh-food storage compartment and of the food freezer compartments;
- b) refrigerator-freezer type II — having user-adjustable means for the separate regulation of the temperatures of the fresh-food storage compartment and of the food freezer compartments.

NOTE Where there is another kind of compartment, there can be additional means of regulating that compartment's temperature.

5 Materials, design and manufacture

5.1 General

Refrigerating appliances shall be constructed in such a manner as to ensure adequate performance and durability in use. Their performance in use is checked by applying a series of relevant tests, which shall be recorded in the final test report (see Clause 19).

5.2 Materials and finishes

Materials used inside refrigerating appliances shall not transmit odours or taste to food. A test procedure for guidance is given in Annex C.

Materials used inside refrigerating appliances shall not contaminate food placed in contact with them nor transmit poisonous substances to food. They shall be resistant to the action of moisture and food acids.

All surface finishes shall be resistant to impact, sufficiently hard, colour-fast, smooth, easily washable, and resistant to damage by moisture and by food acids.

5.3 Thermal insulation and air-tightness

The thermal insulation of the refrigerating appliances shall be efficient. In particular, the insulating material shall not be subject to shrinkage and shall not allow, under normal working conditions, an excessive accumulation of moisture.

No running water shall appear externally when the refrigerating appliance is subjected to the water vapour condensation test specified in Clause 14.

When the door or lid is closed, there shall be no abnormal ingress of air into the interior. Compliance is checked by the test specified in Clause 9.

5.4 Doors, lids, drawers and fittings

External doors, lids and drawers of refrigerating appliances shall withstand opening and closing without deterioration which could be prejudicial to their air-tightness. Fittings shall be capable of maintaining their proper function. Compliance is checked by the test specified in Clause 11.

It shall be possible to open an external door, lid or drawer on a refrigerating appliance from the inside. Compliance is checked by the test given in Clause 10.

5.5 Shelves and containers

Shelves, containers and similar components shall have adequate mechanical strength. Those used for storing food shall withstand the loading test specified in Clause 12 without showing such distortion that they could no longer fulfil their intended function. In particular, sliding or revolving components shall be capable of their full movement when loaded.

Shelves, containers and similar components which are intended to be removable shall be easily removable.

5.6 Collection and disposal of defrost water

5.6.1 For refrigerating appliances with automatic disposal of defrost water, means shall be provided for collecting completely the defrost water either in a removable internal drip tray, or in an external receptacle wherein the defrost water is evaporated, or by other means. For frost-free refrigerating appliances or compartments, defrost water shall only be collected into external receptacles.

The drip tray or other defrost water receptacle should have adequate volume and, additionally, external drip trays should have adequate evaporating means.

The volume of drip trays of evaporators which are semi-automatically or manually defrosted shall be at least equal to the volume for the related evaporator(s), calculated by multiplying by 1 mm their total surface area on which ice can form.

Any drainage system shall be designed to ensure its proper function. It shall be easily accessible for the clearing of any blockage, and shall be designed so as to prevent any undue ingress of air into the food storage compartment(s).

5.6.2 For refrigerating appliances with manual removal of defrost water, means or instructions shall be provided to enable the collection of defrost water in such a way as to prevent water from flooding the floor beneath the refrigerating appliance and/or damaging foodstuffs that may remain in the refrigerating appliance during defrosting.

The volume of drip trays of evaporators with semi-automatic or manual defrost shall be at least equal to the volume for the related evaporator(s), calculated by multiplying by 1 mm their total surface area on which ice can form.

Any drainage system shall be designed to ensure its proper function. It shall be easily accessible for the clearing of any blockage, and shall be designed so as to prevent any undue ingress of air into the food storage compartment(s).

5.7 Refrigerating system

5.7.1 The mechanical operation of the refrigerating appliance should not give rise to undue noise or vibration.

5.7.2 The design of the condenser should be such as to reduce to a minimum the accumulation of dust.

5.7.3 The evaporator should be so designed or protected so that it will not suffer any damage during the normal use of the refrigerating appliance.

The heat exchange surfaces shall be made of corrosion-resistant material, or shall be finished with a corrosion-proof, non-poisonous coating resistant to temperature changes and alternating frosting and defrosting.

5.7.4 The means of adjustment of temperature control devices, if intended to be adjusted by the user, shall be readily accessible, and their function shall be such as to enable the refrigerating appliance to meet the requirements of the performance tests.

5.7.5 Pipes and connections to moving or resiliently mounted parts should be arranged so as not to generate noise, nor to touch or transmit vibrations to other parts, and should be so designed as to prevent failure due to fatigue. All other pipes and connections should be securely anchored. Where necessary, pipes and valves should be properly insulated.

5.7.6 Suitable means should be provided to prevent water condensed on cold parts from affecting the operation of the unit or its controls, or from causing any other damage to the refrigeration appliance and its surroundings.

6 Storage temperatures

Under the conditions specified in Clause 13, the refrigerating appliance shall be capable of maintaining, simultaneously, the required storage temperatures in the different compartments and the permitted temperature deviations (during the defrost cycle) as given in Table 2 for the different types of refrigerating appliances and for the appropriate climate classes.

NOTE Table 5 gives the storage temperature applicable to the water condensation test specified in Clause 14, the energy consumption test given in Clause 15 and the temperature rise test according to Clause 16.

Table 2 — Storage temperatures

°C						
Fresh-food storage compartment		Food freezer and three-star compartment/cabinet	Two-star compartment/section	One-star compartment	Cellar compartment	Chill compartment
t_{1m}, t_{2m}, t_{3m}	t_{ma}	t^{***}	t^{**}	t^*	t_{cm}	t_{cc}
$0 \leq t_{1m}, t_{2m}, t_{3m} \leq 8$	$\leq +4$	$\leq -18^a$	$\leq -12^a$	≤ -6	$+8 \leq t_{cm} \leq +14$	$-2 \leq t_{cc} \leq +3$
^a As a result of a defrost cycle, the storage temperatures of frost free and/or adaptive defrost refrigerating appliances are permitted to rise by no more than 3 K during a period not greater than 4 hours or 20 % of the duration of the operating cycle, whichever is the shorter. An example of an operating cycle for a frost-free refrigerator-freezer is given in Figure 1.						

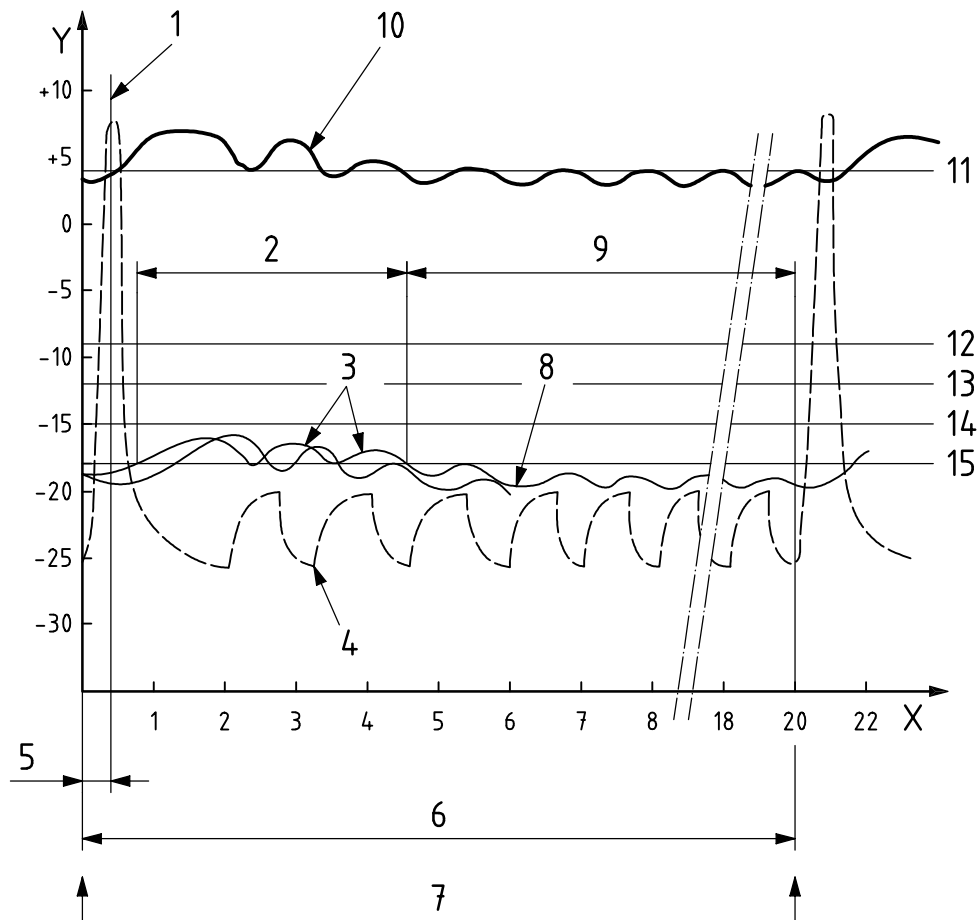

Key

- X time, h
- Y temperature, °C
- 1 start of the refrigerating process
- 2 period of 20 % of the operating cycle of max. 4 h when elevated temperatures are allowed for M-packages in the freezer compartment
- 3 instantaneous temperatures of different M-packages
- 4 temperature of evaporator
- 5 automatic defrosting cycle
- 6 operating cycle
- 7 moments when the means of defrosting is switched on
- 8 instantaneous temperature of the warmest M-package
- 9 period under which the conditions in Table 2 should apply, with the exception of footnote a)
- 10 t_a
- 11 t_{ma}
- 12 $t^{**} + 3 \text{ K}$
- 13 t^{**}
- 14 $t^{***} + 3 \text{ K}$
- 15 t^{***}

Figure 1 — Example of operating cycle for frost-free refrigerator-freezer

7 Determination of linear dimensions, volumes and areas

7.1 Determination of linear dimensions

Linear dimensions shall be measured to the nearest millimetre.

The measurements shall be carried out on the refrigerating appliance as delivered and not operating. If there is a cellar compartment, the volume of which is adjustable, measurements shall be made with this compartment adjusted to both its minimum and maximum volumes.

The overall dimensions shall be measured as the height, width and depth of the rectangular parallelepiped, whose base is horizontal, within which the refrigerating appliance is inscribed to include the complete appliance except for the handle — the protrusion of which, if any, is to be specified separately.

The overall space required in use shall be measured as the height, width and depth, including the handle, increased by the space necessary for free circulation of the cooling air when the refrigerating appliance is in service, plus the space necessary to allow opening of the means of access to that minimum angle permitting removal of all removable parts such as containers and shelves, including a drip tray that has to be removed and any water that has to be emptied manually (see Figure 2).

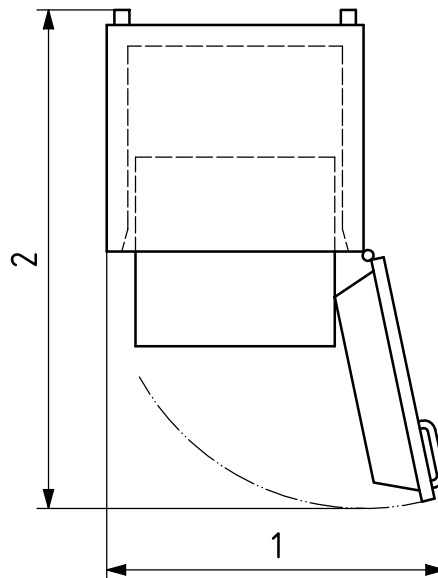

Key

- 1 width
- 2 depth with open door

Figure 2 — Overall space required in use (upright type)

7.2 Determination of volumes

7.2.1 General

Calculated volumes shall be expressed to the nearest whole number of cubic decimetres or of litres

7.2.2 Determination of gross volume

The gross volume shall be calculated by dividing the total volume into convenient units of volumes of geometric shapes, which can easily be measured.

When the gross volume is determined, internal fittings such as shelves, removable partitions, containers, evaporators, temperature control devices and interior light housings shall be considered as not being in place. However, the gross volume shall take into account the exact shapes of the walls if they contain depressions or projections. For an example, see Figure 22 a), b), c), d).

7.2.3 Determination of the total storage volume

The total storage volume shall be the sum of the storage volumes of all compartments, including two-star section(s), as applicable.

For the determination of storage volumes, the total volume of devices and of spaces considered unusable for the storage of food shall be deducted from the gross volume calculated in accordance with 7.2.2.

7.2.4 Storage volume of fresh-food storage, chill and cellar compartments

The storage volume of the fresh-food storage, chill and cellar compartments shall be the gross volume of the compartment minus

- the volume of the evaporator space,
- the volume of any housings (such as those for interior lights, temperature-control devices and other devices),
- the volume of shelves, partitions, retainers and other accessories whose wall thickness is greater than 13 mm according to 7.2.9.1, and
- the space between the inner door protrusion and the inner liner of the fresh-food storage compartment, chill and cellar compartment, unless it is intended for the storage of food.

Where the volumes of the cellar compartment and fresh-food storage compartment are adjustable relative to one another by the user, the storage volumes of these compartments shall be determined with the cellar compartment adjusted to its minimum and maximum volumes.

7.2.5 Volume of evaporator space

7.2.5.1 Volume

The volume of the evaporator space shall be the product of the depth, width and height.

7.2.5.2 Depth

The depth of the evaporator space shall be the mean horizontal distance between the front and rear surfaces of the enclosed space of the cabinet, measured at the level of the evaporator, unless there is a space provided in front of the evaporator for food storage.

Where a storage space is located in front of the evaporator, the depth of the evaporator space shall be taken as the mean horizontal distance from the inner surface of the rear of the enclosed space of the cabinet to the foremost part of the evaporator, or of the evaporator door if fitted.

7.2.5.3 Width

The width of the evaporator space shall be the overall horizontal width of the evaporator itself (neglecting suction headers near the top of the evaporator) or, if side ribs are used, the overall width including the ribs.

If there is less than 70 mm horizontal distance between the evaporator or the ribs and an inside wall of the enclosed space of the cabinet, such space shall be considered as part of the evaporator space.

7.2.5.4 Height

The height of the evaporator space shall be the mean vertical distance between the lower limit of the evaporator and the upper partition of the food storage compartment.

If the free space between the upper surface or top of the evaporator and the upper partition of the food storage compartment exceeds 40 mm, it shall be added to the storage volume of the fresh-food storage compartment.

The evaporator height shall include any internal drip tray and/or drip collector, except in the case when the storage height of the drip tray is greater than 40 mm and a definite manual operation is also needed to initiate defrosting.

7.2.6 Storage volume of ice-making compartments

The storage volume of the ice-making compartments shall be the sum of the volumes of all the compartments of this type in the refrigerating appliance.

The volumes of these compartments shall be determined in a similar manner to that specified in 7.2.3 and 7.2.4, as appropriate.

7.2.7 Storage volume of food freezer compartments/cabinets and frozen-food storage compartments/cabinets

For the determination of the storage volume, the total volume which is unsuitable for storage shall be determined and then deducted from the gross volume determined according to 7.2.2.

The total volume to be deducted shall comprise the following (for examples, see Figure 24):

- a) the volume of spaces situated outside any load limit (natural or marked by the manufacturer);
- b) the volume of spaces provided specifically for making and storing ice, except in the case of refrigerating appliances fitted with automatic icemakers, when the volume occupied by a removable storage bucket shall be included in the storage volume unless it is specified in the instructions for use that this volume is suitable for the storage of ice only;
- c) the volume of spaces between the front stack(s) of the test package load (see 13.3.2.2) and the inner vertical surface of the door or any projection from the door where the horizontal distance between the front face of the stack(s) and the inner door surface or projection exceeds 15 mm;
- d) the volume of all fixed components within the load limits;
- e) the volume of spaces which are to be kept free for the satisfactory performance of the refrigerating system;
- f) the volume of all removable parts which are stated by the manufacturer as necessary for the proper functioning of the refrigerating appliance, except shelves and partitions whose thickness is not greater than 13 mm (see 7.2.9.1);
- g) the volume rendered unusable by the use of removable parts (e.g. baskets, shelves) necessary for obtaining satisfactory thermal and mechanical characteristics (see also 8.6.4);
- h) any volume where the vertical clearance is less than 52 mm;
- i) any volume where it is impossible to place an M-package of nominal dimensions in any position;
- j) the storage volume of any two-star section(s).

There is no equivalence between the value of the storage volume determined in accordance with the principles mentioned above and the volume of the packages loaded into the refrigerating appliance for the storage and freezing tests. The free spaces specified in the test methods could be utilized in normal use and their volume should not be deducted from the gross volume when calculating the storage volume.

7.2.8 Two-star sections and/or compartments in food freezer compartments/cabinets and in three-star compartments/cabinets

Two-star sections and/or compartments are permitted both in the door and in the remaining storage volume when all the following conditions are met:

- a) the two-star section or compartment is marked with the appropriate identification symbol;
- b) the two-star section and/or compartment is separated from the three-star storage volume by a partition, container, or similar construction;
- c) the rated total two-star storage volume does not exceed 20 % of the three-star storage volume of the compartment (or cabinet);
- d) the instructions for use give clear guidance regarding the two-star section and/or compartment;
- e) the storage volume of the two-star section and/or compartment is stated separately and is not included in the three-star storage volume.

7.2.9 Volumes of shelves and partitions (for examples, see Figure 25)

7.2.9.1 Thickness

The thickness of a shelf or partition shall be the mean distance between its outer surfaces.

Where the surface of a shelf or partition is corrugated or fitted with external pipe grids, the surface shall be the plane joining the outer apexes of the corrugations or pipes, unless the distance between adjacent corrugations or pipes is greater than 100 mm.

7.2.9.2 Full shelves and partitions

The volume of a full shelf or partition shall be the product of its thickness and its depth, width or height, whichever two of these are applicable. The depth, width and height shall be those dimensions of the enclosed space of the cabinet which apply in the plane of the shelf or partition.

7.2.9.3 Fractional shelves and partitions

A horizontal shelf or partition, the edges of which are more than 70 mm from the surfaces of the enclosed space of the cabinet, shall be regarded as a fractional shelf or partition. A vertical partition, the edges of which are more than 100 mm from the surfaces of the enclosed space of the cabinet, shall be regarded as a fractional partition.

The volume of a fractional shelf or partition shall be the product of its thickness and its depth, width or height, whichever two of these are applicable.

The depth, width or height shall be the distances from the adjacent surfaces of the enclosed space of the cabinet, and normal to those surfaces, to the further edges of the shelf or partition, or to the evaporator in cases where the fractional shelf or partition touches it.

7.3 Determination of storage shelf area

7.3.1 General

The area shall be expressed in square decimetres or square metres.

7.3.2 Determination of shelf area

7.3.2.1 Full shelf composed of single part

In the case of a full shelf composed of a single part, the area shall be the product of the width and depth. These two dimensions shall be determined as follows.

Width: mean distance measured parallel to the surface of the shelf between the inner surfaces of the side walls of the enclosed space of the cabinet, where this dimension does not exceed the actual width of the shelf by more than 20 mm [see Figure 18 a)].

Depth: mean distance measured parallel to the surface of the shelf (or of the bottom of the refrigerating appliance) between the inner surfaces of the front and rear walls of the enclosed space of the cabinet, where this dimension does not exceed the actual depth of the shelf by more than 20 mm [see Figure 18 b)]. When the door of an upright-type refrigerating appliance is provided with shelves, this distance shall be determined by analogy [see Figure 18 c) and d)].

7.3.2.2 Fractional shelves

For the purpose of calculating the area of fractional shelves, the width and depth shall be measured parallel to the surface of the shelves in a similar way to that for full shelves, but taking into account Figure 18 e).

7.3.2.3 Cut-away shelves

When a shelf is cut away, the area of the portion cut out shall be deducted.

7.3.2.4 Juxtaposed shelves

In the case of juxtaposed shelves, the depth shall be determined in accordance with Figure 18 d).

7.3.2.5 Door shelves

The area shall be the product of the width and depth. These two dimensions shall be determined by analogy with 7.3.2.1, as follows.

Width: mean distance between the inner surfaces of the side walls of the door compartment or between the side edges of the retainer bar.

Depth: mean distance between the surface of the door wall and the vertical plane tangential to the inner front surface of the shelf or retainer bar [see Figure 18 c)].

7.3.2.6 Baskets and containers

The area shall be the product of the two mean horizontal dimensions [see Figure 19 a)].

7.3.2.7 Particular cases

7.3.2.7.1 General

The bottom of the enclosed space of the compartment shall be considered as a shelf.

When an inner wall is not vertical, the dimension of the shelf shall be measured at the mid-height between the shelf under consideration and the shelf or horizontal surface immediately above.

7.3.2.7.2 Fresh-food storage compartment, and chill and cellar compartments

Any part of a full shelf, basket or the bottom of a compartment having less than 100 mm vertical clearance above, when all the shelves and baskets are in position, shall be excluded when calculating the storage area. However, it is admissible that for one full shelf or basket the vertical clearance may be reduced to not less than 80 mm [see Figure 19 b].

7.3.2.7.3 Food freezer compartment/cabinet and low-temperature compartment/cabinet

Any part of a full shelf, basket or the bottom of a food freezer compartment, or cabinet, or frozen-food storage compartment or cabinet, having less than 52 mm vertical clearance above, when all the shelves and baskets are in position, shall be excluded when calculating the storage area [see Figure 19 b)].

In the case of an ice-making compartment, the minimum vertical clearance shall not be less than 40 mm.

7.3.3 Drip tray

Whenever the space occupied by the drip trays is included in the storage volume, the part of the shelf supporting the drip tray or the bottom of the drip tray shall be considered as part of the storage shelf area, provided that a definite manual operation is needed to initiate defrosting.

7.3.4 Suspended containers

7.3.4.1 Fresh-food storage compartment, chill and cellar compartment

The area of the interior surface of the bottom of a suspended container and the area of the shelf immediately below shall not both be counted, unless the vertical clearance between this shelf and the exterior surface of the bottom of the container is at least 100 mm.

Nevertheless, in the case of one container — and one only — this minimum clearance may be reduced to 80 mm to the extent where this possibility has not been applied for the shelves.

If the minimum vertical clearance within a suspended container, as measured between the interior surface of the bottom and the cover, or to the shelf immediately above, is less than 40 mm, the bottom area of the container shall not be added.

7.3.4.2 Food freezer compartment/cabinet and low-temperature compartment/cabinet

For a food freezer compartment or cabinet, or frozen-food storage compartment or cabinet, the dimension of the minimum vertical clearances specified in 7.3.4.1 shall be 52 mm in all cases.

For an ice-making compartment, the minimum vertical clearance dimension shall be 40 mm in all cases.

8 General test conditions

8.1 General

The order of carrying out the tests need not necessarily follow the sequence of the clauses. The results of the tests shall appear in a test report. When necessary, particular information to be noted in this report is mentioned as a special item of the subclause concerning the test.

The manufacturer's storage plans shall be used, provided that they are in accordance with 13.3.

Tolerances on linear dimensions shall be $\pm 5\%$ unless otherwise stated.

8.2 Ambient temperatures

The ambient temperature is measured at two points, T_{a1} and T_{a2} , located at the vertical and horizontal centreline of the sides of the refrigerating appliance and at a distance of 350 mm from the refrigerating appliance (see Figure 3).

It is the arithmetical average of the time-integrated temperatures that is measured and which is the value used for the tests.

Ambient temperatures are measured using copper or brass cylinders (see 8.7) at each of the two measurement points.

Ambient temperature sensors shall be shielded from any sources or sinks of radiant heat in the test room, including conditioning equipment, external windows or other appliances under test.

Ambient temperatures shall be kept constant within $\pm 0,5$ K both during the periods required for obtaining stable operating conditions and during the tests.

The vertical ambient temperature gradient from the platform specified in 8.4 to a height of 2 m shall not exceed 1 K/m measured at the same vertical axis as for the ambient temperature measurement.

Tests shall be carried out under the following conditions of measured ambient temperature.

a) For checking the storage temperatures:

- | | |
|---------------------|--|
| + 10 °C and + 32 °C | for class SN refrigerating appliances; |
| + 16 °C and + 32 °C | for class N refrigerating appliances; |
| + 16 °C and + 38 °C | for class ST refrigerating appliances; |
| + 16 °C and + 43 °C | for class T refrigerating appliances; |

For a rated range of climate classes, tests shall be performed at the extreme ambient temperatures of the range of rated classes.

EXAMPLE For refrigerating appliances rated from SN to T, tests are performed at + 10 °C and at + 43 °C.

b) For checking the energy consumption, temperature rise time, freezing capacity and ice-making capacity of all refrigerating appliances, as applicable:

- | | |
|---------|--|
| + 25 °C | for class SN, class N and class ST refrigerating appliances; |
| + 32 °C | for class T refrigerating appliances. |

c) For all other tests: at the temperature stated in the test specifications.

8.3 Humidity

Unless otherwise specified, relative humidity shall not exceed 75 % .

8.4 Installation of refrigerating appliances

Each refrigerating appliance shall be placed on a wooden solid-top platform²⁾ painted dull black and open for free air circulation under the platform. The bottom of the platform shall not be less than 0,05 m above the test room floor and shall extend at least 0,3 m beyond all sides of the refrigerating appliance, except at the rear where it shall extend to the vertical partition.

The air temperature shall be measured using copper or brass cylinders (see 8.7) 20 to 30 mm below the bottom of the platform. The value shall be at ambient temperature $\pm 1,0$ K. The measurement point shall be on the vertical axis through the geometrical centre of the refrigerating appliance.

The temperature measurement is performed before the refrigerating appliance is started.

Circulation of air around the refrigerating appliance shall be restricted by surrounding the refrigerating appliance with three vertical partitions made of wood, 16 to 30 mm thick, painted dull black and arranged as follows.

- a) One of the partitions shall be placed parallel to the rear of the refrigerating appliance: for free-standing appliances, against the stops; for built-in appliances, at the distance specified by the manufacturer in connection with the required overall space. At the rear of this partition there shall be a sufficient air gap to the room wall (≥ 30 mm) to minimize the influence of adjacent structures.
- b) The two other partitions shall be parallel to the sides of the cabinet, and shall be fixed on the platform 0,3 m from the sides of the cabinet; they shall be 0,3 m wide.
- c) The whole partition structure shall have the form and dimensions shown in Figure 3.

2) A suspended floor under which a temperature reading can be taken meeting the other specifications of a platform is to be regarded as a platform.

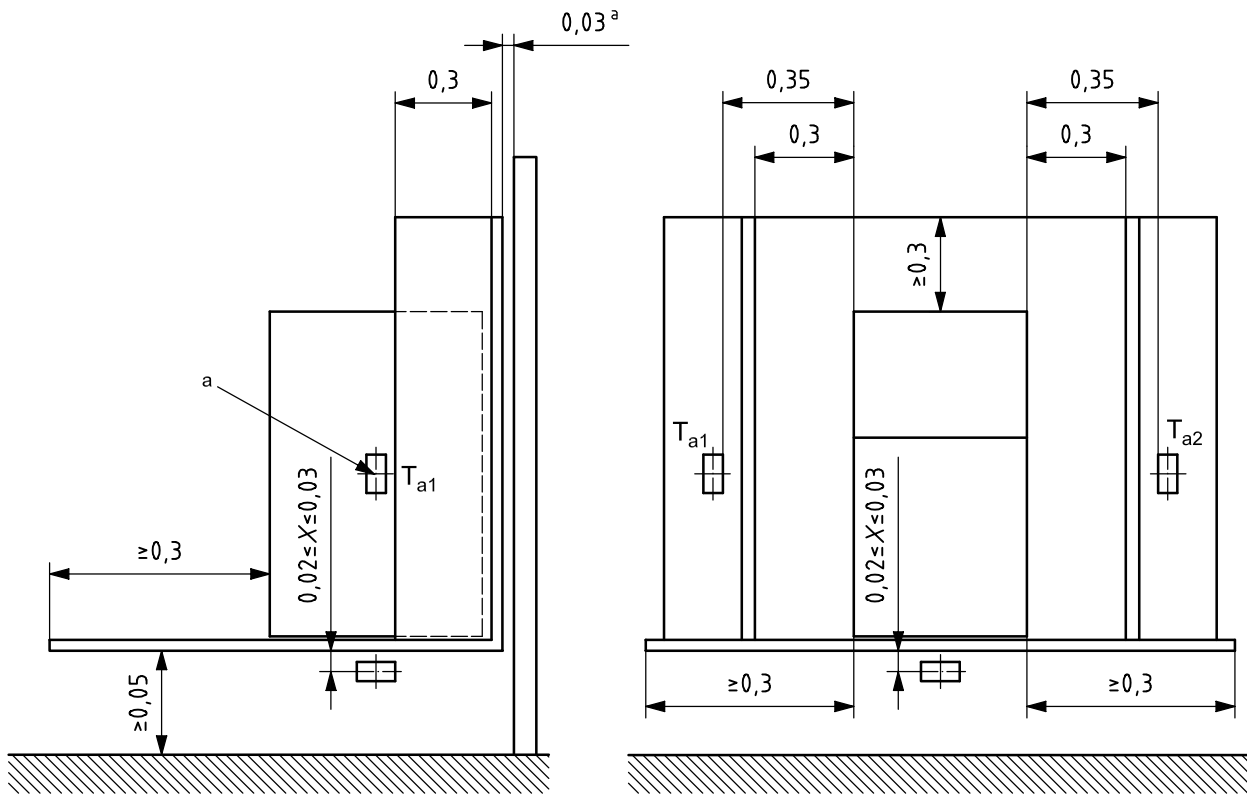

Air velocity measurement < 0,25 m/s at centre of all accessible appliance walls (also top), 0.3 m distance.

^a Distance to wall of test room > 0,03 m.

Figure 3 — Partition to restrict air circulation and ambient temperatures sensor position

The vertical partitions shall present no discontinuity. They shall be of such a height that they extend at least 0,3 m above the top of the refrigerating appliance.

The refrigerating appliance shall be so placed or shielded as to prevent direct radiation to or from the space cooling or heating equipment or windows in the test room, and shall be placed far enough away from all other objects in the test room to ensure that the air surrounding the refrigerating appliance is at ambient temperature.

Air circulation in the test room shall be such that the specified ambient temperatures are obtained within the limits of the specified tolerances. The refrigerating appliance under test shall be shielded from any air currents of velocity above 0,25 m/s.

NOTE The back wall may have a different temperature than the test room when placed in contact with the test room walls. This is due to radiation and conduction of the condenser of the refrigerating appliance and to the surface temperature of the test room wall, which in its turn depends on the surrounding of the test wall.

The air circulation in the test room shall not interfere with the normal air circulation created by the refrigerating appliance.

Refrigerating appliances intended to be built-in shall be built in according to the manufacturer's instructions and Annex D.

Built-in refrigerating appliances intended to be combined with appliances other than refrigerating appliances shall be subjected to the tests while they are combined, but while the other appliance is not functioning.

8.5 Test packages

8.5.1 Dimensions and tolerances

The test packages used in the tests shall be in the form of rectangular parallelepipeds. Their size, prior to freezing, and their mass, packaging included, shall be in accordance with Table 3.

Table 3 — Test package dimensions and mass

Dimensions mm	Tolerance mm	Mass g	Tolerance %
25 × 50 × 100	± 2,0	125	± 2
50 × 50 × 100	for dimensions 25 and 50	250	
50 × 100 × 100	± 3,0	500	
25 × 100 × 200	for dimensions 100 and 200	500	
50 × 100 × 200		1 000	

Test packages shall be checked regularly and shall not present visible holes or cracks on the wrapper.

When any package is found to exceed a tolerance according to Table 3, it shall be replaced by a new package.

8.5.2 Composition

The packages shall consist of the following.

- a) A suitable filling material containing, per 1 000 g:
- 230 g of oxyethylmethylcellulose;
 - 764,2 g of water;
 - 5 g of sodium chloride;
 - 0,8 g of 6-chloro-*m*-cresol.

The freezing point of this material is – 1 °C (its thermal characteristics correspond to those of lean beef).

- b) The following alternative composition of test packages with a freezing point near – 5 °C may be used:
- 232 g of oxyethylmethylcellulose;
 - 725 g of water;
 - 43 g of sodium chloride;
 - 0,6 g of 6-chloro-*m*-cresol.

In case of dispute, the composition of test package a) shall be used as the reference test package.

For the measurement of chill compartments, only test package b), with a freezing point of – 5 °C, shall be used.

- c) A wrapper, consisting of a sheet of plastic or any other suitable material of such a nature that exchange of moisture with the ambient medium is negligible. After filling, the wrapping sheet shall be sealed. It is advisable to use a laminated sheet, consisting of layer of high-pressure polyethylene, easily sealable, 120 µm thick, together with an external sheet of polyethyleneterephthalate approximately 12,5 µm thick, the two layers being bonded together.

8.5.3 M-packages

Some of the 500 g packages (50 mm × 100 mm × 100 mm) shall be equipped for temperature measurement, being fitted with thermocouples or another temperature-measuring device giving equivalent precision, which shall be inserted in the geometrical centre of the packages in direct contact with the filling material. All precautions shall be taken to minimize extraneous conduction of heat. These packages are called M-packages. The composition and the limitations of their use shall be in accordance with 8.5.1 and 8.5.2

8.6 Operating requirements for refrigerating appliances

8.6.1 Temperature-control device setting

The temperature-control device setting requirements are specified for each test.

When the refrigerating appliance is fitted with a temperature control device which is not designed for adjustment by the user, the refrigerating appliance shall be tested in the condition as delivered.

8.6.2 Anti-condensation heaters

If a refrigerating appliance is fitted with an anti-condensation heater which can be switched on and off by the user, this shall be switched on for the tests according to Clauses 13, 17 and 18.

If adjustable, it shall be set at maximum heating.

8.6.3 Power supply (see Annex A)

8.6.3.1 Electric power supply

The refrigerating appliance shall be tested at the rated voltage or at the mean of the rated voltage range $\pm 1\%$ and at the rated frequency $\pm 1\%$.

8.6.3.2 Power supply other than electric

Refrigerating appliances other than those for electric power supply shall be tested under supply conditions corresponding to the information on the rating plate.

8.6.3.3 Multiple power supply

Refrigerating appliances that are equipped for operation on different power supplies shall be tested for each of the supply conditions indicated on the rating plate.

8.6.4 General conditions for the use of baskets, containers, shelves and trays

All shelves, but only those baskets, containers and trays which have been considered in place when determining the storage volume, shall be in position.

8.6.5 Accessories

Accessories that are not necessary for the normal operation of the refrigerating appliance shall remain non-operational during testing.

8.7 Measuring instruments

8.7.1 Temperature probes

According to 8.8, temperatures shall be measured with temperature probes, the sensors of which are inserted either in M-packages or in the centre of solid cylinders made of brass or tin-covered copper having a mass of $25 \text{ g} \pm 5 \%$ and of minimum external area (diameter = height = about 15,2 mm).

The cylinders should be kept clean to keep the emissivity coefficient low.

The temperatures shall be recorded.

Connections from the measuring instruments shall be arranged to prevent air leakage into the food storage compartment.

Temperature-measuring instruments shall have an overall uncertainty of measurement of not greater than $\pm 0,5 \text{ K}$. This accuracy shall be maintained throughout the temperature measuring circuit. Regular calibration of temperature equipment is required at the temperature range of interest.

When required, a data acquisition system shall be capable of recording temperature values with measuring intervals not greater than 60 s.

8.7.2 Humidity

The relative humidity shall be measured and recorded at a point which is representative. The accuracy of the measuring instruments shall be such that the result, expressed as the dew point, shall have an overall uncertainty of measurement of not greater than $\pm 0,3 \text{ K}$.

8.7.3 Watt-hour meters

Watt-hour meters shall be readable to 0,001 kW h and be accurate to within $\pm 1 \%$ of the total energy consumption measured during the test period (i.e. 1 % of reading). Calibration of Watt-hour meters shall be performed at the range used in the measurements.

The measuring accuracy shall be stated in the test report.

8.8 Measurement of storage temperature

8.8.1 Fresh-food storage compartment and cellar compartment

The temperatures t_{1m} , t_{2m} and t_{3m} (see 3.6.2) and t_{c1m} , t_{c2m} , t_{c3m} (see 3.6.4) shall be measured using copper or brass cylinders, except for the freezing test of refrigerator-freezers, when they shall be measured in M-packages suspended and located at the temperature-sensing points.

For determining the storage temperature, the temperature-sensing points shall be located at T_1 , T_2 , T_3 and T_{c1} , T_{c2} , T_{c3} , as shown in Figures 14 and 15, halfway between the rear internal wall of the appliance and the internal wall of the closed door.

For the freezing test for refrigerator-freezer, the M-packages shall be supported or suspended in order to have their geometrical centre at the temperature-sensing points and so that their largest surface is horizontal. The M-packages shall be separated from any heat-conducting surface by at least 25 mm of air space. The instantaneous temperatures of the M-packages t_1 , t_2 and t_3 , and t_{c1} , t_{c2} and t_{c3} shall be recorded.

The M-packages may be supported — e.g. by use of a block of expanded polystyrene (EPS) of the same base dimensions as the M-package.

The temperatures t_{1m} , t_{2m} and t_{3m} , and t_{c1m} , t_{c2m} and t_{c3m} at the temperature-sensing points shall be the integrated time averages of t_1 , t_2 and t_3 , and t_{c1} , t_{c2} and t_{c3} , respectively, during an operating cycle with an integral step of 60 s or less.

The storage temperatures t_{ma} (see 3.6.2) and t_{cma} (see 3.6.4) are the arithmetical average of the mean temperatures t_{1m} , t_{2m} and t_{3m} and t_{c1m} , t_{c2m} and t_{c3m} , respectively.

If internal components do not allow the temperatures t_1 , t_2 and t_3 , and t_{c1} , t_{c2} and t_{c3} , to be read at the points specified, readings may be taken in positions such that the geometrical centre of the cylinder or the M-package is no more than 25 mm from the point specified. If the interior arrangement of the fresh-food storage and cellar compartments does not conform to those shown in Figures 14 and 15, the temperatures t_1 , t_2 and t_3 , and t_{c1} , t_{c2} and t_{c3} , shall be read in positions determined by analogy with the positions indicated.

The temperatures shall be recorded.

8.8.2 Chill compartment

For determining the storage temperature of the chill compartment, the storage plan shall be in accordance with 13.3.1.

The temperature t_{cc} (see 3.6.5) shall always be measured in M-packages positioned or suspended with their largest surface horizontal at least 25 mm away from all walls and ceilings and from the other packages of the test load.

The temperature t_{cc} shall be recorded during an operating cycle at intervals not greater than 60 s.

In chill compartments, M-packages shall be placed where the highest and lowest temperatures are expected.

In the case of a chill compartment with special subdivisions (shelves, etc.) which is part of the design, and if the dimensions are too small to allow the horizontal positioning of the M-packages, it is permissible to position them vertically.

Moreover, if the dimensions are too small to accommodate an M-package (for example in door shelves), a special support shall be used to position the M-package next to the shelf and as close as possible to the door liner.

8.8.3 Measurement of temperature of food freezer compartment/cabinet and frozen-food storage compartment/cabinet/section

The temperatures shall be measured in M-packages, which are distributed throughout the load of test packages specified in the storage plan (see 13.3.2).

The above measurements made during an operating cycle shall be recorded at intervals not greater than 60 s.

The temperature of each compartment, cabinet or section is the maximum temperature of any M-package in that compartment, cabinet or section. The conditions given in Table 2 shall apply.

8.9 Determining stable operating conditions

Stable operating conditions are considered to exist when the refrigerating appliance has been left running for a minimum time according to the manufacturer's instruction without any adjustment of temperature control setting(s) during this time, and when the storage temperatures and energy consumption values during two periods of at least 24 h — both comprising a full number of operating cycles — agree within 0,5 K and 3 % respectively. If a single operating cycle is longer than 48 h, the values of storage temperatures and energy consumption from the first 24 h of two successive operating cycles are compared.

8.10 Test period

After stable operating conditions have been attained, the test period shall start at the beginning of an operating cycle. It shall be of at least 24 h duration and shall comprise a whole number of operating cycles. If an operating cycle starts but is not completed during 24 h, the test shall continue until the end of that operating cycle. If one operating cycle is not completed during 48 h, the test shall be terminated after 48 h, except for food freezers and refrigerator/freezers where there is no air exchange between the food freezer compartment and other compartments, in which case the test shall be terminated after 72 h.

8.11 Measurement of temperature rise time

This is the period between the moment when — under specified test conditions — the temperature of the warmest M-package in the food freezer compartment or cabinet, or in any three-star compartment or cabinet, reaches -18 °C to the moment when any of the M-packages (excluding any two-star sections) first reaches a temperature of -9 °C after the operation of the refrigerating system has been interrupted.

9 Testing air-tightness of doors, lids or drawer seals

9.1 General

The purpose of this test is to ensure that the gaskets of the door(s) or lids of the refrigerating appliance adequately prevents any abnormal ingress of the surrounding air.

9.2 Test conditions, preparation and procedure

The ambient temperature shall be between $+16\text{ °C}$ and 32 °C . The refrigerating appliance shall be switched off and shall be in equilibrium with the ambient temperature before carrying out the test.

A strip of paper 50 mm wide and 0,08 mm thick and of suitable length shall be inserted at any point of the seal, and the door or lid shall be closed normally on it. The verification of the thickness of the paper used shall be in accordance with ISO 534.

The seal shall be assessed by checking that the strip of paper does not slide freely.

NOTE The most unfavourable points can be found by inspecting the area around the seal with the refrigerating appliance closed and illuminated from the inside.

10 Testing opening force of doors or lids

The purpose of this test is to check that the doors or lids can be opened from the inside.

Compliance shall be checked by inspection and by performance of the relevant tests of IEC 60335-2-24:—, Clause 22.

11 Testing the durability of doors, lids and drawers

11.1 General

The purpose of these tests, carried out using the following procedures, is to check the durability of the hinges and handles of doors, lids and drawers.

11.2 External doors and lids

11.2.1 Test conditions/preparation

The ambient temperature shall be between + 16 °C and + 32 °C.

The refrigerating appliance shall be switched off.

The door shelve(s) shall be loaded in accordance with 13.3.2.8 or Clause 12, as appropriate.

11.2.2 Opening sequence (see Figure 4)

The movement of the door shall be controlled from an angle of 0° to an angle of opening between 5° and 15°, followed by a free movement of the door, the controlled movement being approximately sinusoidal. The opening of the door shall take place in the first quarter of the period of the cycle.

11.2.3 Closing sequence (see Figure 4)

The movement of the door shall be controlled from the angle of opening of 45° to an angle between 40° and 35°, followed by the free movement of the door and its closing as in normal use.

The number of cycles per minute shall be 10 to 25.

- For compartments with an internal temperature $T \geq -6 \text{ °C}$, external doors and lids shall withstand 100 000 opening and closing operations without deterioration which could be prejudicial to the air-tightness of the door or lid.
- For compartments with an internal temperature $T \leq -6 \text{ °C}$, external doors and lids shall withstand 30 000 opening and closing operations without deterioration which could be prejudicial to the air-tightness of the door or lid.

Compliance shall be checked after the procedure using the test according to Clause 9.

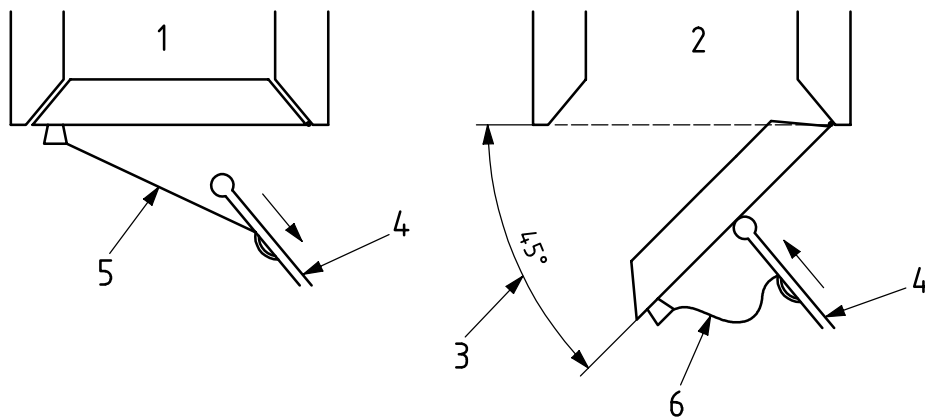

- Key**
- 1 door opening
 - 2 door closing
 - 3 angle of opening
 - 4 pusher
 - 5 taut cable
 - 6 slack cable

Figure 4 — Example of opening and closing external door(s)

11.3 External drawers

11.3.1 Test conditions/preparation

The ambient temperature shall be between + 16 °C and + 32 °C.

The refrigerating appliance shall be switched off.

All baskets, shelves and containers shall be loaded in accordance with Clause 12.

11.3.2 Opening sequence (see Figure 5)

The drawers shall be pulled out to within 15 to 20 mm of their fully open position.

11.3.3 Closing sequence (see Figure 5)

The drawers shall be closed as in normal use from within 15 to 20 mm of their fully open position.

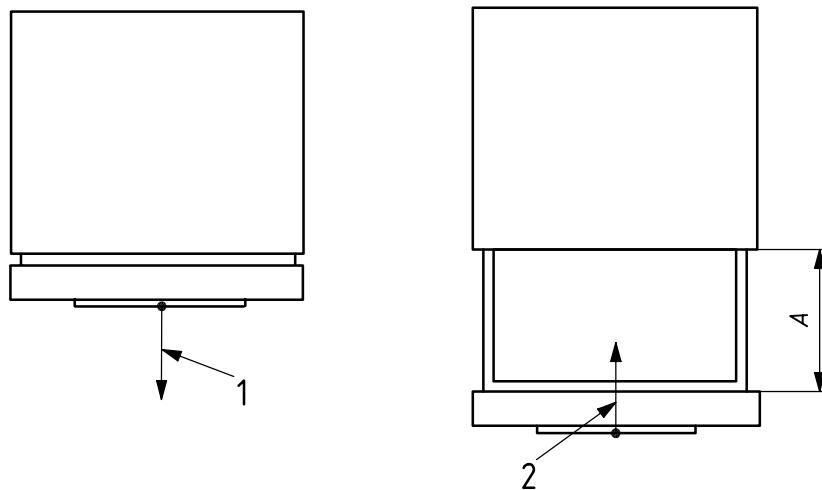

Key

- A opening course
- 1 pull out
- 2 push

Figure 5 — Example of opening and closing of external drawer(s)

The number of cycles per minute shall be between 5 and 10.

— For compartments with an internal temperature $T \geq -6$ °C,

- 1) single drawers shall withstand 100 000, and
- 2) multiple drawers shall each withstand 50 000,

opening and closing operations without deterioration which could be prejudicial to the air-tightness of the drawer sealing.

— For compartments with an internal temperature $T \leq -6$ °C, each drawer shall withstand 30 000 opening and closing operations without deterioration which could be prejudicial to the air-tightness of the drawer sealing.

Compliance shall be checked after the procedure using the test according to Clause 9.

12 Testing mechanical strength of shelves and similar components

12.1 General

The purpose of this test is to check the mechanical strength of the components used for storing food — shelves, containers, evaporators, etc. — and to verify that the requirements in 5.5 are met.

12.2 Temperature

The ambient temperature shall be between + 16 °C and + 32 °C.

12.2.1 Food freezer compartment/cabinet, frozen-food storage cabinet and low-temperature compartment

After the storage temperature test (see Clause 13), and with the refrigerating appliance switched off, the behaviour of all loaded shelves, baskets and containers and their supports shall be examined. All sliding or revolving shelves and containers shall be moved, without modification of their load, to the half-way position ($A/2$) of their permissible course (see Figure 6) except that, if stops are provided which limit the movement to less than the half-way position, the components shall be moved to their stop. They shall be left in this position for 1 h and then returned to their initial position.

If the manufacturer has stated in the instructions for use that some shelves or containers slide out for maintenance or transportation, but must remain in a definite position in normal use, they shall be considered as fixed and the checking shall be carried out in the same position as for the storage temperature test.

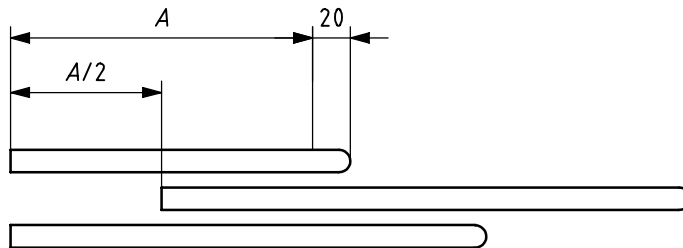

Key

A permissible course

Figure 6 — Test position for sliding components which have no limiting stop

12.2.2 Fresh-food storage, chill and cellar compartments

The refrigerating appliance shall be switched off, with the door(s) open.

The components to be tested shall be loaded in turn with 80 mm diameter cylindrical weights of 1 000 g, except in the case of components above which the clear height in normal service cannot exceed 150 mm, for which the weights shall be 500 g.

Components which are specially designed to hold eggs shall not be loaded.

The weights shall be placed with their axes vertical and such that the maximum possible number is accommodated without one weight being placed over another and without overlapping the edge of the component under test.

In the case of sliding or revolving shelves and containers, the test shall be carried out in accordance with 12.2.1

In the case of door shelves, the diameter of the weights may be changed, if necessary, to adapt them to the shape of the shelves, provided the load per unit area is the same.

The applied loads shall remain in position for 1 h.

13 Testing storage temperatures

13.1 General

The purpose of this test is to check compliance with the requirements of Clause 6 at each of the ambient temperatures (see 8.2) for the appropriate climate class.

13.2 Preparation of refrigerating appliance

The refrigerating appliance shall be installed in the test room in accordance with 8.4. The evaporator(s) shall be defrosted and the internal walls and components of the refrigerating appliance dried. The means of access (doors or lids) shall be kept closed during the tests.

The refrigerating appliance shall be set up as in service in accordance with the manufacturer's instructions. All internal fittings supplied with the refrigerating appliance, including ice trays, shall be put in position, except that the ice trays shall be removed in the case of a food freezer compartment or cabinet, or frozen-food storage compartment or cabinet, having no specific subdivision to accommodate such trays.

If the refrigerating appliance has temperature-control devices designed for adjustment by the user, they shall be set at the manufacturer's recommended positions for normal operation at the appropriate ambient temperature. When the devices are not designed for adjustment by the user, the measurement shall be carried out on the refrigerating appliance as delivered.

Readjustment may be allowed when required to compensate for different ambient temperatures and/or different operating conditions of the other compartments during the tests specified in Clauses 13, 17 and 18.

Anti-condensation heaters shall be set in accordance with 8.6.2.

The empty refrigerating appliance shall be operated for at least 24 h to reach equilibrium.

The fresh-food storage and cellar compartments shall be equipped in accordance with 8.7 and 8.8.1.

The chill compartment, food freezer compartment or cabinet and any frozen-food storage compartment(s) or cabinet shall be equipped with test packages and M-packages in accordance with 13.3, as appropriate.

13.3 Storage plan

13.3.1 Chill compartment

The chill compartment shall be loaded with packages according to 8.5.2 b) and the following.

- For chill compartments with a storage volume ≤ 10 l: two M-packages.
- For chill compartments with a storage volume > 10 l: two M-packages plus one additional 500-g test package for each additional 10 l of storage volume — up to 10 packages max. — in accordance with Table 4.

There shall always be at least two M-packages and test packages may be replaced by M-packages.

Table 4 — Chill compartment storage load

Storage volume, V , of chill compartment	No. of packages
I	
$V < 10$	2
$10 \leq V < 20$	3
$20 \leq V < 30$	4
$30 \leq V < 40$	5
$40 \leq V < 50$	6
$50 \leq V < 60$	7
$60 \leq V < 70$	8
$70 \leq V < 80$	9
$V \geq 80$	10

13.3.2 Food freezer and frozen-food storage compartments/cabinets

13.3.2.1 The food freezer compartment or cabinet and any frozen-food storage compartment or cabinet shall be filled with as many test packages as it can hold, the test packages having previously been brought to a temperature approximately equal to the classification temperature of the compartment.

13.3.2.2 On each horizontal surface intended for storage, the largest possible number of stacks of 1-kg test packages, having a base of 100 mm × 200 mm, shall be made.

NOTE A *stack* is a number of packages piled on top of one another (faces with largest surface horizontally); the term does not necessarily imply that packages form a "straight" pile.

Stacks of packages shall be placed in direct contact with horizontal loading surfaces and vertical surfaces (see 13.3.2.4). Case a) as shown in Figure 7 is correct since none of the exceptions listed in 13.3.2.4 apply (the drawing applies to 0,5-kg as well as 1-kg packages). However, this is not completely consistent, as if individual packages in a stack were to be placed in contact with the vertical surface, there would be no need to include exception b) in 13.3.2.4.

Distances between stacks with "shifted" packages shall be according to Figure 8:

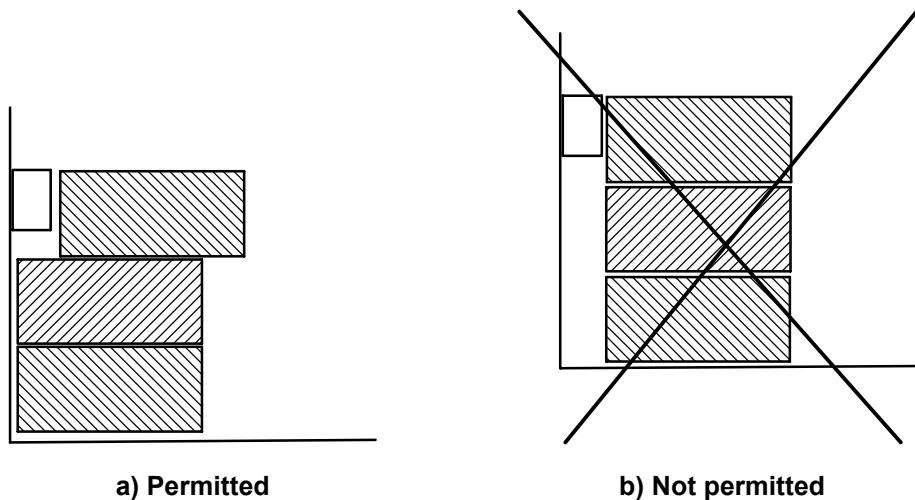

Figure 7 — Examples of shifted package stack

Dimensions in millimetres

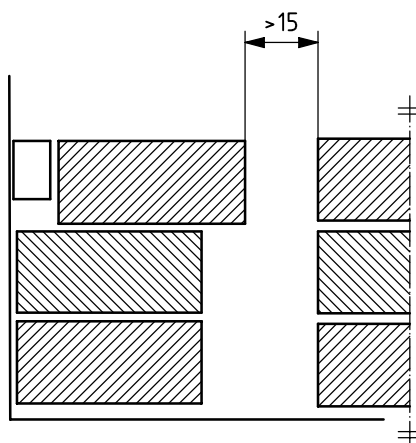

Figure 8 — Example of multiple stacks with shifted package

When an M-package has to be placed in a stack, it shall also be placed flat, side-by-side with another 500-g package of the same size, excepting in the case of door shelves (see 13.3.2.8).

If a volume constrained by natural load limits can only contain a single stack with a base of 100 mm × 100 mm, M-packages may be placed flat in this stack.

If necessary, the loading may be completed by stacks having a base of 100 mm × 100 mm made up of 500-g packages laid flat, and then finally by stacks having a base 50 mm × 100 mm made up of 125-g or 250-g packages, also laid flat, or else 25 mm × 100 mm × 200 mm 500 g packages.

Four 125-g or two 250-g packages may be replaced by one 500-g (50 × 100 × 100) package placed vertically.

13.3.2.3 The height of the stacks shall be such that the vertical clearance between the upper edge of the highest package and the inner surface of the lid, shelf or horizontal surface situated immediately above is greater than 10 mm but less than 35 mm

In order to satisfy these requirements, 125-g or 250-g packages, or 25 × 100 × 200 500-g packages laid flat, shall be used and placed as close as possible to the middle of any stack.

The number of packages for each stack shall first be determined in accordance with their nominal thickness dimensions: 50 mm and 25 mm. For the actual loading, the packages shall then be chosen such that, taking into account their individual thickness, the vertical clearance above each stack is within the limits.

13.3.2.4 Stacks of packages shall be placed in direct contact with the horizontal loading surfaces and vertical surfaces except in the following cases.

- a) When the vertical surface is the inner surface of a door, the stacks shall be loaded as follows:
- if there is a marked load-limit line, the packages shall be loaded up to that line [see Figure 16 a)];
 - if there is no load-limit line, but a natural load limit, the packages shall be loaded up to that limit [see Figures 16 b) and Figure 16 g)];

NOTE Internal doors, edges of shelves, baskets or flaps are considered natural load limits.

However, manufacturers can declare in the instructions for use that flaps and internal doors are removable and are non-essential for proper functioning of the refrigerating appliance. In that case, packages shall be loaded to 15 mm from the vertical surface of the door and the manufacturer can claim the complete volume of the compartment.

If the manufacturer claims the whole volume of the compartment as storage volume, even if there is a natural load limit, the packages shall be loaded to within 15 mm from the inner vertical surface of the door or any projection from the door; in that case, packages may overhang the front edge of any shelf (see Figure 16 c) and d).

- b) When the intersection of a horizontal loading surface and a vertical surface is radiused, the bottom package of any stack shall be placed in direct contact with the horizontal loading surface, and the remainder of the stacks shall project beyond the bottom package so as to be in contact with the vertical surface [see Figures 16 e), f), and h)].

13.3.2.5 If a subdivision is provided specifically for making and storing ice and is not removable without the use of tools, the ice trays shall be filled with water, and the contents frozen and placed in position before the compartment is loaded with test packages; otherwise, the ice trays and the subdivisions shall be removed and the whole compartment loaded with packages.

In the case of refrigerating appliances fitted with automatic icemakers, the ice storage bucket shall be removed and the resulting volume considered as frozen-food storage volume, unless it is specified in the instructions for use that this volume is suitable for the storage of ice only. The automatic icemaker shall not be in operation during the test.

13.3.2.6 Free air spaces of 15 mm minimum (calculated from the nominal dimensions of the test packages), as far as possible equal, shall be left between adjacent stacks of test packages.

The use of spacers to maintain free air spaces between stacks of test packages is permissible provided that the spacers are of the smallest possible cross-section and of the lowest possible thermal conductivity and are placed in such a way that they do not significantly interfere with normal air circulation.

13.3.2.7 M-packages shall be placed where the highest temperatures are expected (for examples, see Figure 17). These placements may be different for the storage temperatures, energy consumption and temperature rise tests.

13.3.2.8 Door shelves and compartments shall also be loaded with as many packages as possible. Packages shall be placed in such a position that the free air spaces between the packages and the inner surface of the door and between the packages and the retainer are equal. In the case of door shelves and compartments, the packages may, if necessary, be placed horizontally or vertically. However, 125-g packages shall only be placed flat and shall not be used as vertical wedges. Spacers may be used to maintain the stability of the stacks (see 13.3.2.6).

13.4 Refrigerating appliances with adjustable cellar compartment

If the refrigerating appliance includes a cellar compartment and the volumes of this compartment and of the fresh-food storage compartment can be changed in relation to one another by the user, the cellar compartment shall be adjusted to its minimum volume for the test in high ambient temperature and to its maximum volume for the test in low ambient temperature (see 8.2).

13.5 Measurements

For the appropriate ambient temperature, the temperature control device(s) and other controls, if any, shall be adjusted, as necessary, to a position which is likely to give storage temperatures which comply with Clause 6, after stable operating conditions have been attained.

13.6 Test report

The test report shall contain at least the following information for each ambient temperature (as appropriate):

- a) the ambient temperature;
- b) the setting(s) of temperature-control device(s) and other controls, if any (if designed for adjustment by the user);

- c) the value of the fresh-food storage temperature t_{ma} , and the values of t_{1m} , t_{2m} and t_{3m} ;
- d) the value of the cellar compartment t_{cma} and the values of t_{c1m} , t_{c2m} , t_{c3m} , as appropriate, during a test period (see 8.9);
- e) the values of the highest maximum temperature(s) [see g)] and the duration of the temperature deviation above -18 °C (or -12 °C) and the duration of the operating cycle (see Table 2).
- f) the values of the maximum and minimum recorded chill compartment temperatures t_{cc} ;
- g) a sketch of the storage plan showing the locations of the M-packages and the location of the M-package with the highest maximum temperature in each of these compartments or cabinets, and in any two-star section, and the location of the M-packages with the highest maximum temperature during the temperature deviation as a result of the defrost cycle;
- h) a sketch of the storage plan of the chill compartment, showing the locations of the M-packages with the highest and the lowest temperatures.

14 Water vapour condensation test

14.1 General

The purpose of this test is to determine the extent of condensation of water on the external surface of the cabinet under specified ambient conditions.

14.2 Procedure

14.2.1 Ambient temperature

The ambient temperature (see 8.2) shall be

- + 25 °C for class SN and N refrigerating appliances
- + 32 °C for class ST and T refrigerating appliances

14.2.2 Relative humidity

The relative humidity shall be such that the dew point is

- + 19 °C ± 0,5 °C for class SN and N refrigerating appliances
- + 27 °C ± 0,5 °C for class ST and T refrigerating appliances

14.2.3 Preparation of the refrigerating appliance

The temperature control device, the installation, the controls and the loading of the refrigerating appliance shall be the same as for the energy consumption test (see Clause 15).

If anti-condensation heaters are provided which can be switched on and off by the user, these shall be switched off. If, however, running water appears on the external surface of the refrigeration appliance, the test shall be repeated with the anti-condensation heaters switched on and — if adjustable — set at maximum heating.

14.2.4 Test period

After stable operating conditions have been attained, all external surfaces of the cabinet shall be carefully wiped dry with a clean cloth and the test continued for a period of 24 h. The test period shall be selected during the period when condensation is most likely to occur.

14.3 Observations

During the test period, external surface areas exhibiting fog, droplets or running water shall be outlined and coded by the letters “A”, “B” and “C”, respectively. See Figure 9.

14.4 Expression of results and test report

A coded sketch shall be made showing the running water area appearing during the test on all external surfaces; code C as shown in Figure 9 shall be used to indicate this. Codes A and B may also be included

The test report shall also indicate the selected test period and the duration of the period of observation and shall state whether any manual switch provided for anti-condensation heaters was switched on or off in accordance with 14.2.3.

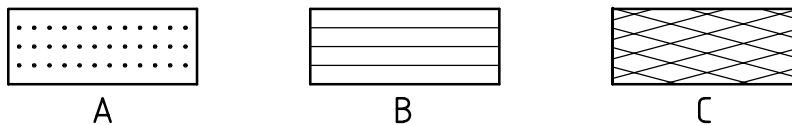

- Key**
- A fog
 - B droplets
 - C running water

Figure 9 — Condensation codes

15 Energy consumption test

15.1 General

The purpose of this test is to measure the energy consumption of refrigerating appliances under specified test conditions.

NOTE In some countries, a different method of measuring energy consumption is required by law (see Annex A).

15.2 Procedure

15.2.1 Ambient temperature (see Annex A)

The ambient temperature shall be in accordance with 8.2.

15.2.2 Preparation of the refrigerating appliance

The refrigerating appliance shall be installed and loaded as for the storage temperature test (see 13.2). If, however, anti-condensation heaters are provided which can be switched on and off by the user, they shall be switched on if required by 14.2.3 and — if adjustable — set at maximum heating.

If the refrigerating appliance includes a cellar compartment and the volumes of this compartment and of the fresh-food storage compartment are adjustable in relation to one another by the user, the cellar compartment shall be adjusted to its minimum volume.

15.3 Measurements

15.3.1 General temperature conditions (except for refrigerator-freezer)

15.3.1.1 For the purpose of these tests, the *target temperature* is the warmest permissible storage temperature of each compartment given in Table 5 for the determination of energy consumption.

15.3.1.2 When all the storage temperature conditions in accordance with Table 2 are met simultaneously, the value measured during the test period of 8.9 giving the lowest energy consumption is the recorded value.

The measurement of energy consumption shall be carried out under storage conditions with all compartments simultaneously under operation.

15.3.1.3 The energy consumption shall be determined either by one test at the target temperatures or by interpolation from the results of two tests. When interpolation is used, the temperature obtained from one of the two tests shall be warmer than the target temperature, and the temperature obtained from the other of the two tests shall be colder than the target temperature. The difference between the two temperatures used for the interpolating test shall not exceed 4 K.

In the case of two tests, the results shall be interpolated (for examples, see Figure 10).

15.3.2 General temperature conditions (for refrigerator-freezer)

The energy consumption is that which would be obtained when all of the following target temperature conditions are met:

- a) $t_{ma} = + 5 \text{ }^\circ\text{C}$ with $0 \text{ }^\circ\text{C} \leq t_{1m}, t_{2m}, t_{3m} \leq + 10 \text{ }^\circ\text{C}$;
- b) $t_{cma} = + 12 \text{ }^\circ\text{C}$ with $+ 8 \text{ }^\circ\text{C} \leq t_{c1m}, t_{c2m}, t_{c3m}$ (as appropriate) $\leq + 14 \text{ }^\circ\text{C}$, where a cellar compartment is provided;
- c) $t_{cc} \leq + 3 \text{ }^\circ\text{C}$;
- d) the maximum temperature (t^{***}) of the warmest M-package in the food freezer compartment and any three-star frozen-food storage compartment equals $- 18 \text{ }^\circ\text{C}$;
- e) the maximum temperature (t^{**}) of the warmest M-package in a two-star section within the food freezer compartment and with any three-star frozen-food storage compartment equals $- 12 \text{ }^\circ\text{C}$;
- f) the maximum temperature (t^{**}) or (t^*) of the warmest M-package in any two-star compartment or in any one-star compartment equals $- 12 \text{ }^\circ\text{C}$ or $- 6 \text{ }^\circ\text{C}$ respectively;

Because these various temperature conditions cannot, in general, be attained simultaneously, the energy consumption shall be that corresponding to those of the above conditions which can be obtained simultaneously and which give the lowest energy consumption: their number depending on the number of possibilities of adjustment; the other values complying with the basic temperature requirement as a maximum temperature limit.

15.3.3 Refrigerator-freezers, Type I

15.3.3.1 Temperature conditions

The energy consumption shall be that corresponding to one of the temperature conditions given under columns a to d in Table 5.

15.3.3.2 Determination of the energy consumption

The energy consumption shall be determined either at one of the target temperatures or by interpolation from the results of two tests: one giving a temperature warmer than, and the other a temperature colder than, the target temperature of $t^{***} = -18\text{ °C}$ for condition a, $t^{**} = -12\text{ °C}$ for condition b, $t_{ma} = +5\text{ °C}$ for condition c, or $t_{cma} = +12\text{ °C}$ for condition d, according to Table 5.

The difference between the two temperatures used for the interpolating test shall not exceed 4 K.

In the case of two tests, the results shall be interpolated to meet the requirements of one of conditions a to d according to Table 5 (for examples, see Figure 10).

15.3.4 Refrigerator-freezers, Type II

15.3.4.1 Temperature conditions

The energy consumption shall be that corresponding to one of the temperature conditions given under columns e to h in Table 5.

Where it is possible to make independent measurements of the energy consumption of the fresh-food storage compartment and cellar compartment and of the food freezer compartment and any additional frozen-food storage compartments, the test to 15.3.4.2 shall be carried out. Where it is not possible to carry out independent measurements, the test of 15.3.4.3 shall be carried out.

Table 5 — Energy-storage temperature conditions for determining energy consumption

Storage temperature for energy test	°C									
	Refrigerators and Type I refrigerator-freezers				Type II refrigerator-freezers, with food freezer compartment temperature-control device				Frozen-food storage cabinets and food freezers	
	a	b	c	d	e	f	g	h		
t^{***} a g	-18^b	≤ -18	≤ -18	≤ -18	-18^c	≤ -18	-18^c	≤ -18	-18	≤ -18
t^{**} d g	≤ -12	-12^b	≤ -12	≤ -12	≤ -12	-12^c	≤ -12	-12^c	≤ -12	-12
$t_{ma}^{e f}$	$\leq +5$	$\leq +5$	$+5^b$	$\leq +5$	$+5^c$		$\leq +5$		—	—
t_{cma}^f	$\leq +12$	$\leq +12$	$\leq +12$	$+12^b$	$\leq +12$		$+12^c$		—	—
t_{cc}	$\leq +3$	$\leq +3$	$\leq +3$	$\leq +3$	$\leq +3$		$\leq +3$		—	—

If there are any two-star sections or one-star compartments, the temperature conditions for these sections or compartments shall be $\leq -12\text{ °C}$ or $\leq -6\text{ °C}$, as appropriate.

If there are any chill compartments, the maximum value of t_{cc} shall be as close as possible to, but shall not exceed, $+3\text{ °C}$.

A compartment shall be tested in the condition as delivered.

a Maximum temperature of warmest M-package in the food freezer compartment and in any three-star frozen-food storage compartment.

b In general, these temperatures are obtained by interpolation in accordance with 15.3.3.

c In general, these temperatures are obtained by interpolation in accordance with 15.3.4.

d Maximum temperature of the warmest M-package in any two-star section or compartment.

e With $0\text{ °C} \leq t_{1m}, t_{2m}, t_{3m} \leq +10\text{ °C}$

f For t_{ma} and t_{cma} the conditions are either
 $t_{ma} = +5\text{ °C}$ with $+8\text{ °C} \leq t_{cma} \leq +12\text{ °C}$ (but as close as possible to $+12\text{ °C}$ if adjustment is possible — for example by flaps),

or

$t_{cma} = +12\text{ °C}$ with $t_{ma} \leq +5\text{ °C}$ (but as close as possible to $+5\text{ °C}$ if adjustment is possible — for example, by flaps).

g As a result of a defrost cycle, the permitted temperature rise for food freezer and three-star cabinet/compartment and section and for two-star compartment in accordance with Table 2, applies.

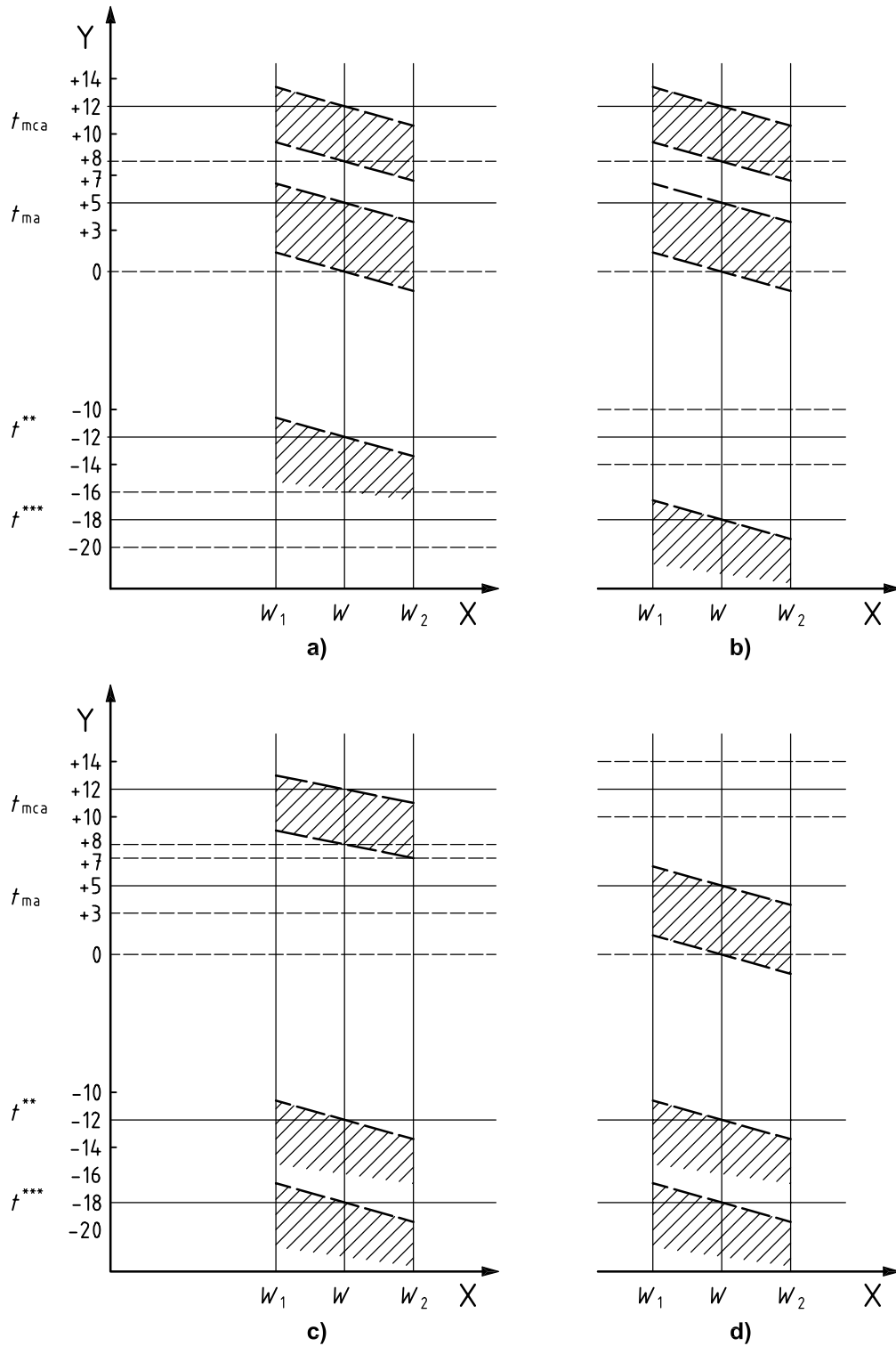

Refrigerators and Type I refrigerator-freezers (see 15.3.3 and Table 5)

Figure 10 — Determination by interpolation of energy consumption — Refrigerators and types I and II refrigerator-freezers

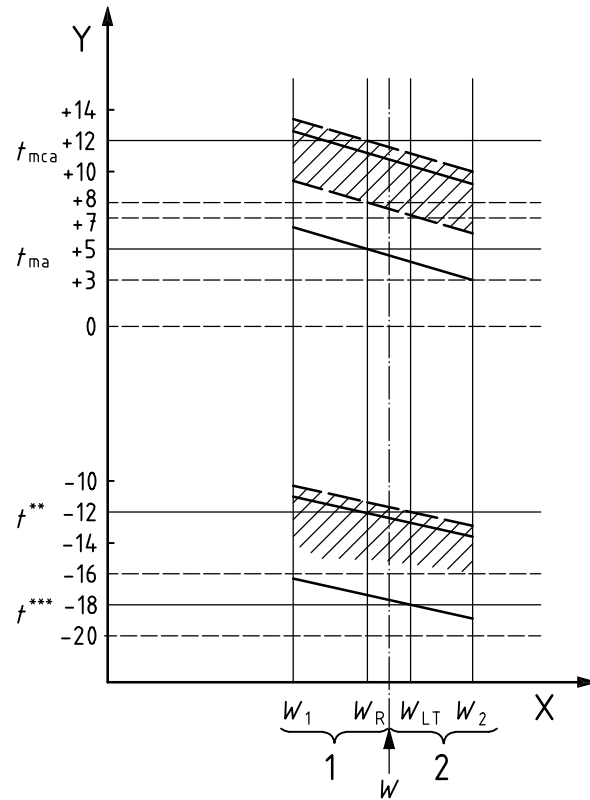

$$W = \frac{(W_R + W_{LT})}{2}$$

Type II refrigerator-freezers (see 15.3.4 and Table 5)

Key

- X energy consumption, W , kWh/24h
- Y temperature, t , °C
- W interpolated energy consumption of whole appliance
- W_1 result of first test
- W_2 result of second test
- W_R interpolated energy consumption of whole appliance with specified condition for fresh-food storage compartment satisfied
- W_{LT} interpolated energy consumption of whole appliance with specified condition for low-temperature compartment satisfied

NOTE The hatched areas show permissible ranges. See Table 5.

Figure 10 — Determination by interpolation of energy consumption — Refrigerators and types I and II refrigerator-freezers (continued)

15.3.4.2 Determination of energy consumption — First case

The energy consumption of a fresh-food storage compartment or a cellar compartment shall be determined at the appropriate target temperature for one compartment, or by interpolation from the results of two tests — one test giving a temperature warmer than, and the other test a temperature colder than, the target temperature $t_m = + 5\text{ °C}$ or $t_{cm} = + 12\text{ °C}$ (see Table 5, conditions e to h). The particular condition chosen shall be that which gives the lower energy consumption.

Similarly, the energy consumption of the food freezer compartment, any three-star frozen-food storage compartment, or any two-star section shall be determined for the target temperature of $-18\text{ }^{\circ}\text{C}$ or $-12\text{ }^{\circ}\text{C}$, respectively (see Table 5 food freezer conditions).

If the energy consumption of the fresh-food storage compartment or food freezer compartment is measured independently, then the compartment for which the energy consumption is not measured shall be operated at or below, but as close as possible to, its target temperature.

The temperature variation from the above-mentioned target temperatures used as the basis for the energy consumption determination shall be within the limit of $\pm 2\text{ K}$. When the measurement is done independently for each compartment, the energy consumption of the refrigerating appliance shall be the sum of the energy consumption of each compartment.

15.3.4.3 Determination of the energy consumption — Second case

The energy consumption shall be determined at the target temperature for the fresh-food storage compartment, cellar compartment, food freezer compartment or frozen-food storage compartment, or by overall interpolation between the results of two tests.

When interpolation is used, the temperature obtained from one of the two tests shall be warmer than the target temperature for the chosen compartment, and the temperature obtained from the other of the two tests shall be colder than the target temperature for that compartment (see Figure 10). The difference between the two temperatures used for the interpolating test shall not exceed 4 K.

15.4 Test report

The value of the energy consumption shall be calculated for a period of exactly 24 h from the measured value.

The energy consumption of electrically operated refrigerating appliances shall be expressed in kilowatt hours per 24 h (kW h/24 h), to two decimal places.

16 Temperature rise test

16.1 General

The purpose of this test is to check the time for the temperature rise of test packages in a frozen-food storage cabinet or compartment, or food freezer cabinet or three-star compartment.

16.2 Procedure

16.2.1 Ambient temperature (see Annex A)

The measured ambient temperature shall be in accordance with 8.2.

16.2.2 Preparation of refrigerating appliance

The refrigerating appliance shall be prepared, stabilized and loaded as for the energy consumption test (see Clause 15).

16.2.3 Setting of control devices

Temperature-control devices and other controls (flaps, etc.), shall be set as for the energy consumption test.

If the measured energy consumption is determined by interpolation from the results of two tests, the settings shall be those which gave the colder temperatures in the frozen-food storage compartment used for the interpolation.

16.3 Test period and measurements

The power supply to the refrigerating appliance shall be cut off immediately after the end of an operating cycle. For automatic-defrosting refrigerating appliances, the power supply shall be cut off after the power disconnection point to *compressor off* condition during the stable part of the operating cycle. If there is no compressor cycling, the switch-off time shall be after a defrost but during the stable period of operation. If there are temperature variations, the test shall be commenced at a low temperature point.

These cycles are those of the refrigerating system of the refrigerating appliance, or of the system which refrigerates the food freezer compartment and any three-star compartment.

The period of time shall be noted from the moment when the temperature of the warmest M-package in the food freezer compartment or cabinet, or in any three-star compartment or cabinet, reaches $-18\text{ }^{\circ}\text{C}$ to the moment when any one of the M-packages in any of these compartments or cabinets first reaches $-9\text{ }^{\circ}\text{C}$.

16.4 Test report

The test report shall contain the following information:

- the ambient temperature;
- the time for the temperature rise from $-18\text{ }^{\circ}\text{C}$ to $-9\text{ }^{\circ}\text{C}$.

17 Freezing test

17.1 General

The purpose of this test is to check the freezing capacity of food freezers and food freezer compartments under specified test conditions.

17.2 Procedure

17.2.1 Ambient temperature (see Annex A)

The ambient temperature shall be in accordance with 8.2.

17.2.2 Preparation of refrigerating appliance

The refrigerating appliance shall be installed according to 8.4.

If the refrigerating appliance includes a cellar compartment the volume of which can be changed by the user in relation to the volume of the fresh-food storage compartment, the cellar compartment shall be adjusted to its maximum volume.

Anti-condensation heaters shall be set in accordance with 8.6.2.

The empty refrigerating appliance should be set up and operated for at least 24 h to reach equilibrium, as for the preparation for the storage temperature test (see 13.2).

17.2.3 Loading of refrigerating appliance

17.2.3.1 Chill, cellar and fresh-food storage compartments

The cellar and fresh-food storage compartments shall be loaded with M-packages at the sensing points in accordance with 8.81.

The chill compartment shall be loaded with M-packages and test packages as for the storage temperature measurement test of 13.

17.2.3.2 Food freezer compartment/cabinet — Ballast load

The food freezer compartment or cabinet shall be loaded with test packages and M-packages to form a ballast load. The mass of packages used shall be 40 kg/100 l of the total storage volume of the compartment(s) or cabinet, with the exception of any two-star section(s) or compartments.

If it is not possible to accommodate the light load in the remaining space, the ballast load shall be reduced as necessary to 80 %, 60 % or 40 % of the above-specified values.

If the manufacturer's instructions indicate that there is a separate section for freezing food, this section shall be used for the light load only.

In all cases, the space left to accommodate the light load shall not exceed the higher value of the following:

- 30 % of the total storage volume of the food freezer compartments or cabinet and any three-star compartments;
- 3 l/kg of light load.

M-packages shall be uniformly distributed throughout the ballast load: there shall be one M-package per 15 kg of load with a minimum of 4 M-packages.

Additionally, door shelves and door containers — if any — within the compartment(s) or cabinet shall be loaded with one or two M-packages, according to the space available.

Any two-star section or compartment within the food freezer compartment or cabinet and any separate three-star compartment shall be fully loaded with test packages and M-packages as for the storage test (see 13.2).

The test packages and the M-packages shall be previously brought to a temperature approximately equal to $-18\text{ }^{\circ}\text{C}$

The ballast load packages shall be laid flat and distributed uniformly within the food freezer compartment (or cabinet), the space for the introduction of the light load (see 17.2.4.3) being left empty. Manufacturer's instructions which are not in conflict with the requirements of this International Standard shall also be taken into account. If the manufacturer has given no instructions, the packages shall be distributed evenly throughout the food freezer compartment or cabinet, while leaving space for the light load.

The conditions for loading described in the storage plan (see 13.3) — with the exception of the total quantity of test packages and the space for the light load — shall be fulfilled.

17.2.3.3 Refrigerating appliances with separate three-star compartment

If a refrigerating appliance has a separate three-star compartment with its own external access door or lid, and the manufacturer recommends that, before freezing, all frozen food already in storage be placed in that compartment while leaving the food freezer compartment empty to receive the load for freezing (i.e. the three-star compartment is to be regarded as an extension of the food freezer compartment), a freezing capacity claim based upon this method of use is permissible, provided that

- a) the three-star compartment is of sufficient volume to accommodate the ballast load calculated on the basis of the combined storage volumes of the food freezer compartment and the three-star compartment (excluding any two-star sections or compartments), in accordance with the storage plan (see 13.3),
- b) when tested according to this method of use, the claimed freezing capacity is confirmed and the temperature requirements for the other compartments [see 17.2.4.4.1 a) to f)], if applicable, are fulfilled during the freezing test, and
- c) the claimed freezing capacity is at least equivalent to 4,5 kg/100 l of the combined storage volumes of the food freezer compartment and three-star compartment.

17.2.4 Test procedure

17.2.4.1 Starting conditions

The loaded refrigerating appliance is left to run until stable operating conditions are reached. The temperature-control device setting or the setting of other control devices should be approximately the same as for the energy consumption test (see Clause 15).

After stable operating conditions have been attained, the temperature shall be in accordance with Table 2.

NOTE 1 The temperature indication succession (from left to right in Table 2) also indicates the order of precedence in the case of several temperature possibilities.

NOTE 2 In some circumstances it might be unnecessary to carry out the stabilization specified here before the stabilization specified in 17.2.4.2.

17.2.4.2 Setting of control devices

If the food freezer compartment or cabinet is provided with means for a pre-freezing operation, the procedure specified in 17.2.4.3 shall be carried out as follows.

After stable operating conditions in accordance with 17.2.4.1 have been attained, the appliance shall be set in operation in the pre-freezing condition according to the manufacturer's instructions and the test of 17.2.4.3 shall then be carried out.

If there are no special instructions for pre-freezing, the procedure according to 17.2.4.3 shall be carried out after the refrigerating appliances has reached stable operating conditions in accordance with the temperature requirements of 17.2.4.1.

17.2.4.3 Freezing of the light load

After the conditions according to 17.2.4.2 have been attained, the light load shall be introduced. Changes of setting of manually operated controls are not permitted after the introduction of the light load.

For frost-free refrigerating appliances, the light load shall be introduced at the commencement of a defrosting cycle.

The light load corresponds to the value stated by the manufacturer as that which can be frozen in 24 h and is made up of test packages which have previously been brought to a temperature of $+ 25\text{ °C} \pm 1\text{ K}$ for classes SN, N and ST, and to a temperature of $+ 32\text{ °C} \pm 1\text{ K}$ for class T refrigerating appliances.

The light load packages shall be placed flat and positioned taking into account the manufacturer's instructions and the requirements of the loading storage plan (see 13.3). If no instructions are given, the packages shall be placed such that they will be frozen as rapidly as possible. The use of spacers between adjacent stacks of packages is permitted, but other methods are not.

The light load shall not be placed in physical contact with the ballast load.

M-packages shall be uniformly distributed throughout the light load: there shall be one M-package per 3 kg of load, with a minimum of 2 M-packages.

The temperatures of the M-packages in the ballast load and in the light load shall be recorded, together with those of the M-packages in the other compartment(s), if any (see 17.2.3). This shall be done until the arithmetic mean of the instantaneous temperatures of all the M-packages in the light load reaches -18 °C .

The time necessary for reaching this temperature shall be noted.

During the test, the temperatures in the M-packages of chill compartments, if any, are not measured.

17.2.4.4 Evaluation

17.2.4.4.1 First possibility

If the temperature of the light load is reached in a time between 22 h and 26 h, the mass which would be frozen in 24 h shall be determined from the actual freezing time by proportional calculation.

The test result shall be accepted only provided that

- a) the maximum temperature of any of the M-packages of the ballast load remains equal to or colder than -15 °C and that at the end of the test the maximum temperature of the warmest M-package of the ballast load is $\leq -18\text{ °C}$,
- b) the maximum temperature of the warmest M-package in any separate compartment not used for ballast in accordance with 17.2.3.3 remains $\leq -18\text{ °C}$,
- c) the maximum temperature of the warmest M-package in any two-star section remains $\leq -12\text{ °C}$, excepting in the case of frozen-food storage and/or food freezer cabinets, where this temperature shall be $< -9\text{ °C}$ during the test and $\leq -12\text{ °C}$ at the end of the test,
- d) the maximum temperature of the warmest M-package in any two-star or one-star compartment remains $\leq -12\text{ °C}$ or $\leq -6\text{ °C}$, respectively,
- e) the instantaneous temperature t_a of the fresh-food storage compartment during the test does not exceed $+7\text{ °C}$, with t_1, t_2, t_3 between 0 °C and $+10\text{ °C}$, and
- f) the instantaneous temperatures t_{c1}, t_{c2}, t_{c3} — as appropriate — of the cellar compartment do not drop below 0 °C .

17.2.4.4.2 Second possibility

If the actual freezing time is less than 22 h or more than 26 h and/or the conditions of 17.2.4.4.1 a) to f) are not fulfilled, further tests shall be carried out — if possible with more favourable starting conditions, but still maintaining the temperature limits in accordance with 17.2.4.1 — on the assumption that better results can be expected.

Otherwise, the test shall be repeated with a different load.

17.2.4.4.3 Third possibility

If the actual freezing time is less than 22 h and the conditions of 17.2.4.4.1 a) to f) are fulfilled, but these conditions cannot be fulfilled using a larger light load, the actual load for which the conditions are met shall be considered (without any proportional calculation) to be the mass which can be frozen in 24 h.

17.3 Test report

The test report shall contain the following information:

- a) the mass, in kilograms, of the ballast load;
- b) the mass, in kilograms, of the light load;
- c) the freezing time, in hours, of the light load;
- d) the freezing capacity, in kilograms, determined during the light-load freezing test;
- e) the warmest temperature measured in the M-packages in the ballast load stored during the light-load freezing test, together with the warmest temperature measured in the M-packages in any three-star compartment, two-star section or compartment and in any one-star compartment;
- f) the highest and lowest values of t_1 , t_2 , t_3 and t_{c1} , t_{c2} , t_{c3} , if applicable;
- g) the settings of all temperature-control devices, including the timer, if any;
- h) a sketch of the storage plan for the refrigerating appliance showing the location of the M-packages and the location of the warmest M-package(s);
- i) if the food freezer compartment or cabinet is fitted with a device intended to set it in continuous operation when freezing and then to revert to thermostatic operation automatically, the time which elapsed before the food freezer compartment or cabinet reverted to thermostatically controlled operation;
- j) whether the rated freezing capacity meets the requirements of at least 4,5 kg of test packages per 100 l of its storage volume in 24 h, and in no case less than 2 kg.

18 Ice-making test

18.1 General

The purpose of this test is to determine the ice-making capacity of the refrigerating appliance.

18.2 Procedure

18.2.1 Ambient and water temperatures

The ambient temperature shall be in accordance with 8.2.

The supply water temperature shall be

+ 25 °C ± 1 K for class SN, N and ST refrigerating appliances

+ 32 °C ± 1 K for class T refrigerating appliances

If the refrigerating appliance is connected to a water supply, the temperature shall be measured at the point of connection to the appliance.

18.2.2 Preparation of refrigerating appliance

The refrigerating appliance shall be installed in the test room in accordance with 8.4 and set up as in service in accordance with the manufacturer's instructions. The means of access (doors or lids) shall be kept closed during the test.

Ice trays shall be removed and the fresh-food storage compartment, chill compartment and cellar compartment, if any, shall be equipped according to 8.8.

The food freezer compartment or cabinet and any frozen-food storage compartment(s) or cabinet shall not be equipped with test packages and M-packages.

The temperature-control device shall be set in accordance with the manufacturer's instructions. When no instructions are given, the temperature-control device position shall be the same as that for the storage test (see Clause 13).

Anti-condensation heaters shall be set in accordance with 8.6.2.

The cellar compartment shall be as small as possible (if the volume is adjustable), with temperature-control devices (flaps, etc.) set in the position in accordance with the manufacturer's instructions or the same as that for the storage test.

Where the refrigerating appliance has an automatic defrost, it shall remain in operation for this test but ice-making test shall not be commenced until the termination of a defrost function.

18.2.3 Test procedures

18.2.3.1 Ice tray

After stable operating conditions have been attained, the ice tray(s) shall be filled with water up to 5 mm from the top or at the position indicated by the manufacturer or with the amount of water indicated by the manufacturer and placed in the refrigerating appliance at the position recommended by the manufacturer at the commencement of a defrosting cycle.

If a subdivision is provided specifically for making and storing ice, and is not removable without the use of tools, the ice trays shall be placed in that subdivision.

The water temperature at the moment of placing the ice tray(s) in the appliance shall be in accordance to the supply water temperatures as specified in 18.2.1.

For all the refrigerating appliances, except for frost-free refrigerating appliances, the contact surface of the ice tray(s) shall be wetted to provide good contact with the evaporator.

The ice tray(s) shall be examined for complete freezing of the water after an interval equal to the ice-making time stated by the manufacturer has elapsed or as estimated from the stated ice-making capacities of the refrigerating appliance.

Throughout the ice-making test, none of the instantaneous temperatures t_1 , t_2 , t_3 , t_{c1} , t_{c2} or t_{c3} shall fall below 0 °C; in addition, t_{cc} shall remain in accordance with Table 2.

18.2.3.2 Automatic icemaker

The automatic icemaker(s) shall be connected in accordance with the manufacturer's instruction to a water supply having a temperature as specified in 18.2.1. Prior to initiation of the ice-making test, the automatic icemaker shall have been operating for a sufficient time to assure proper operation. There shall be no evidence of free water having entered the storage bin.

For cycling icemakers, the test shall begin at the completion of the water-fill portion of a cycle. For continuous (non-cycling) ice-making devices, the test may be started at any time after steady state ice-making conditions have been established. The ice storage bin shall be emptied and repositioned at the time the test is started.

For automatic icemakers connected to a storage tank in the fresh-food compartment, this tank shall be filled with water at the beginning of the test.

The test shall continue uninterrupted for a minimum of 12 h for continuous icemakers and for the additional time required to complete a whole number of cycles for cycling icemakers. If the storage bin is emptied during the test to assure uninterrupted operation, ice shall be weighted and this amount added to the weight of the ice in the storage bin at the termination of the test.

At completion of the test, the ice in the storage bin shall be weighed. If there is evidence of free water having entered the storage bin, the test shall be repeated at least once. If this condition continues, the test shall be stopped and the condition reported.

The time duration of the test shall be recorded for use in calculating the ice-making capacity in kilograms per 24 h.

18.3 Test report

18.3.1 Ice tray

The test report shall contain the following information:

- a) ambient temperature and water temperature;
- b) the quantity, in kilograms, of ice produced in a 24-h period or the time, expressed in hours and minutes, necessary to freeze the water in the ice-tray(s) supplied with the refrigerating appliance — if the ice-making capacity is given by time, a conversion shall be made by proportional calculation to determine the ice-making capacity in kilograms per 24 h;
- c) average fresh-food compartment temperature at the beginning of the test;
- d) average food freezer temperature at the beginning of the test;
- e) the type of material of each tray (plastic, metal, etc.);
- f) the weight of each tray;
- g) the position of each tray in the evaporator or food freezer compartment;
- h) temperature-control device setting.

18.3.2 Automatic icemaker

The test report shall contain the following information:

- a) type, model number, serial number of the icemaker;
- b) ambient temperature and water temperature;
- c) average fresh-food compartment temperature at the beginning of the test;
- d) average food freezer temperature at the beginning of the test;
- e) the ice-making capacity in kilograms per 24 h;
- f) temperature-control device setting.

19 Final test report

The final test report shall include reference to this International Standard (i.e. ISO 15502) and shall comprise the measurements and test results of the following:

- a) the overall dimensions;
- b) the overall space required in use;
- c) the total gross volume(s) (see Clause 7);
- d) the storage volume(s) (see Clause 7);
- e) the total storage volume (see Clause 7);
- f) the storage shelf area (see Clause 7);
- g) the defrosting type for each compartment, excepting that of frost-free refrigerating appliances;
- h) air-tightness of door(s) or lid(s) (see Clause 9);
- i) opening force test of doors or lids (see Clause 10);
- j) durability test (see Clause 11);
- k) mechanical strength test (see Clause 12);
- l) storage temperature test (see Clause 13);
- m) water vapour condensation test (see Clause 14);
- n) energy consumption test (see Clause 15);
- o) temperature rise test, (see Clause 16);
- p) freezing test, (see Clause 17);
- q) ice-making test, (see Clause 18).

20 Designation

Refrigerating appliances shall be designated according to the following:

- a) type of refrigerating appliance (single-door or double-door, frost-free refrigerator, food freezer, Type I or Type II, etc.);
- b) operating principle — compression or absorption, and, if absorption, the energy source(s) (electricity, gas or liquid fuel);
- c) the class — extended temperate (SN), temperate (N), subtropical (ST) or tropical (T);
- d) the rated total gross volume, either in cubic decimetres or in litres;
- e) the rated total storage volume, either in cubic decimetres or in litres, together with the rated storage volume of the food freezer compartment, and the star classification(s) and rated storage volume(s) of any frozen-food storage compartment(s) and any two-star section(s);

- f) the rated freezing capacity, in kilograms.

EXAMPLE Two-door compression-type, frost-free refrigerator-freezer, class N, total gross volume, total storage volume, including food freezer compartment having three-star and two-star volume, freezing capacity.

21 Marking

21.1 Rating plate

Each refrigerating appliance shall have one or more securely fastened rating plates.

The following information shall be marked in a permanent and legible manner:

- a) the indication of the type of refrigerating appliance: “refrigerator”, “frozen-food storage cabinet”, “food freezer”, “refrigerator-freezer Type I” or “refrigerator-freezer Type II”, with the designation being prefixed by the term “frost-free” if applicable;
- b) the trademark or name of the manufacturer or responsible vendor;
- c) the model reference;
- d) the serial number and/or date of manufacture, which may be coded;
- e) the rated total gross volume, either in cubic decimetres or in litres;
- f) the rated storage volume, either in cubic decimetres or in litres, of
- 1) the food freezer and three-star cabinet (excluding any two-star section therein),
 - 2) the food freezer compartment (excluding any two-star section or compartment therein),
 - 3) the three-star frozen-food storage compartment(s), if any (excluding any two-star section or compartment therein),
 - 4) the two-star section(s) or compartment(s), if any, within the food freezer and three-star frozen-food storage compartment or cabinet,
 - 5) the two-star compartment(s),
 - 6) the one-star compartment(s),
 - 7) the fresh-food storage compartment,
 - 8) the cellar compartment(s),
 - 9) the chill compartment(s), and
 - 10) ice-making compartment(s);
- g) the letters indicating the climatic class or classes (SN, N, ST, T);
- h) the designation (chemical name, chemical formula or refrigerant number) and (total) mass, in grams, of the refrigerant (see ISO 817);
- i) information relating to the energy source;
- j) the rated freezing capacity, in kilograms;
- k) Type I or Type II, if applicable.

Items b) to d) shall be visible when the refrigerating appliance is in its position of normal use. Other marking shall either be readily visible in normal use or when the refrigerating appliance is away from a wall or after the removal, without any tool, of a flap or grille:

The manufacturer is free to show any other information considered desirable.

21.2 Identification of food freezers and freezer compartments

Food freezers and food freezer compartments or cabinets shall be identified by a symbol readily visible from the front, externally or internally, in accordance with that shown in Figure 11.

Additionally, in the case of a two-star section in a food freezer compartment or cabinet, the standard two-star symbol (see Figure 12) shall be placed to clearly indicate this section.

The symbol shown in Figure 11 shall not make use of more than two colours or exhibit more than two contrasting surface finishes. The colour (or surface finish) of the large star shall be different from that of the three other stars. (For the purpose of this requirement, white and black are considered as colours.) There shall be no marking or decoration anywhere on the refrigerating appliance which could be confused with the food freezer compartment identification symbol.

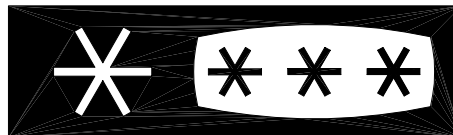

Figure 11 — Identification symbol for food freezer compartment
(for further details, see Figure 20)

21.3 Identification of frozen-food storage compartments or cabinets

Frozen-food storage compartments or cabinets shall be identified by a symbol as shown in Figure 12, readily visible from the front, externally or internally. In the case of a two-star section in a three-star compartment/cabinet, the standard two-star symbol shall appear close to the standard three-star symbol wherever it appears.

The symbol shall not make use of more than two colours or exhibit more than two contrasting surface finishes. (For the purpose of this requirement, white and black are considered as colours.) There shall be no marking or decoration anywhere on the refrigerating appliance which could be confused with the star identification symbols.

NOTE Text and symbol for the identification of a chill compartment is intended to be added when defined.

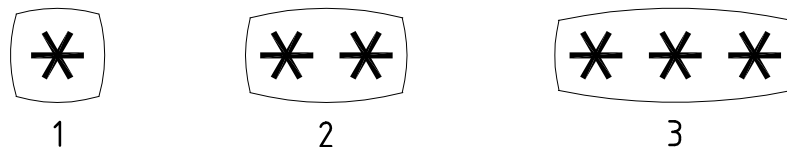

Key

- 1 one-star compartment symbol
- 2 two-star compartment symbol
- 3 three-star compartment symbol

Figure 12 — Star identification symbols for frozen-food storage compartments
(for further details, see Figure 21)

21.4 Load limit lines

Load limit lines are permitted only in relation to food freezer volumes and three-star frozen-food storage volumes in cabinets or compartments with an independent external door.

No load-limit line is necessary if, within the gross volume of any cabinet or compartment suitable for three-star storage

- no space is acknowledged as being unsuitable for three-star storage, or
- the load limits are determined by the particular construction (baskets, containers, flaps, etc.), or
- the load limits are determined by natural load limits (see Figure 16) and the loading conditions are specially described in the instructions for use.

In all other cases, the limits of three-star storage volume shall be indicated in a conspicuous and permanent way by a load-limit line or lines in the form shown in Figure 13.

The manufacturer should avoid, as far as possible, the provision of storage spaces outside the load limits and outside any two-star section or compartments (see 7.2.8).

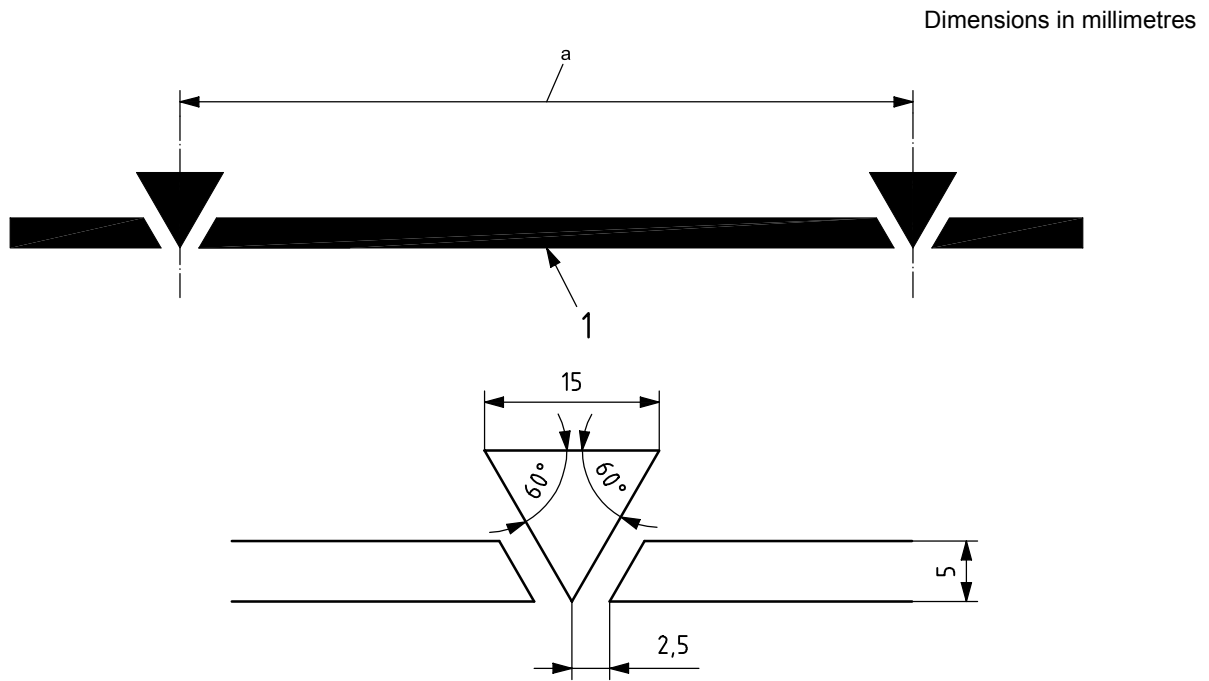

- Key**
- 1 edge denoting load limit
 - a From 100 mm to 150 mm.

Figure 13 — Marking of load limit

22 Technical and commercial product information

Whenever technical and commercial product information is supplied, all declared performance data shall be in accordance with this International Standard. They should contain the designation stated in Clause 21 and may contain the following:

- a) the name of manufacturer or responsible vendor;
- b) the model reference;

- c) a warning that refrigerating appliances — in particular, a refrigerator-freezer Type I — might not operate consistently (possibility of defrosting of contents or temperature becoming too warm in the frozen food compartment) when sited for an extended period below the cold end of the range of temperatures for which the refrigerating appliance is designed;
- d) the overall space required in use — with sketches showing the refrigerating appliance with the means of access open and closed;
- e) for refrigerating appliances which are intended to be built-in, the recess dimensions, together with any additional ventilation requirements;
- f) the direction of opening of the door(s), and whether reversible;
- g) the rated energy consumption (see Clause 15), with a reference to the ambient temperature at which the value was measured;
- h) the temperature rise time, measured in accordance with Clause 16;
- i) the percentage running time, measured in accordance with Annex B,
- j) the ice-making capacity, measured in accordance with Clause 18;
- k) the rated storage shelf area (see 7.3).

23 Instructions for users

Every refrigerating appliance shall be accompanied on delivery by instructions for its installation, use and user maintenance, in the language of the country where it is for sale. These instructions shall include the following:

- a) the installation requirements (best location, levelling, connection — if required — for defrost water, connections to energy source);
- b) the overall space required in use, with sketches showing the refrigerating appliance with the means of access — open and closed;
- c) for refrigerating appliances which are intended to be built-in, the recess dimensions together with any additional ventilation requirements;
- d) a warning that refrigerating appliances — in particular a refrigerator-freezer Type I — might not operate consistently (possibility of defrosting of contents or temperature becoming too warm in the frozen food compartment) when sited for an extended period of time below the cold end of the range of temperatures for which the refrigerating appliance is designed;
- e) the operating conditions (starting and stopping procedures);
- f) the instructions for use of the various controls (temperature control devices, fast-freeze switch, indicator lights, air circulation and defrosting control etc.);
- g) the limit values of the range of ambient temperature for the climate classes for which the refrigerating appliance is designed and the fact that the internal temperatures could be affected by such factors as the location of the refrigerating appliance, ambient temperature and the frequency of door opening, and, if appropriate, a warning that the setting of any temperature control device might have to be varied to allow for these factors;
- h) the care required for best performance, such as
 - 1) loading the refrigerating appliance — especially when the storage volume of the food freezer compartment or cabinet or any three-star compartment(s) or cabinet is smaller than the corresponding gross volume and when no load-limit lines exist,

- 2) the use of baskets and, where appropriate, a warning on the risk of poor performance when some baskets are not used,
 - 3) the arrangement of food for storage, in particular the need to avoid cross-contamination,
 - 4) the arrangement of food for storage and for freezing, where applicable, particularly including advice that food to be frozen is not to be placed in direct contact with food in storage and, if appropriate, that it could be necessary to reduce the quantity to be frozen if freezing every day is anticipated,
 - 5) in the case of refrigerating appliances with chill compartment, a statement to the effect that some types of fresh vegetables and fruits are sensitive to cold, and that therefore they are not suitable for storage in this kind of compartment, and
 - 6) the placing of ice-tray(s) in order to achieve optimal ice-freezing;
- i) the user maintenance and cleaning of the refrigerating appliance;
 - j) defrosting;
 - k) the fact that effervescent drinks should not be stored in food freezer compartments or cabinets or in low-temperature compartments or cabinets, and that some products such as water ices should not be consumed too cold;
 - l) the need to not exceed the storage time(s) recommended by the food manufacturers for any kind of food and particularly for commercially quick-frozen food in food-freezer and frozen-food storage compartments or cabinets;
 - m) the precautions necessary to prevent an undue rise in the temperature of the frozen food while defrosting the refrigerating appliance, such as wrapping the frozen food in several layers of newspaper;
 - n) the fact that a rise in temperature of the frozen food during manual defrosting, maintenance or cleaning could shorten the storage life;
 - o) the care required with regard to frozen food in storage in the event of an extended non-running of the refrigerating appliance (interruption of power supply or failure of the refrigerating system);
 - p) the action to be taken when the refrigerating appliance is switched off and taken out of service temporarily or for an extended period (e.g. emptied, cleaned and dried, and the door(s) or lid(s) propped ajar);
 - q) the necessity that, for doors or lids fitted with locks and keys, the keys be kept out of the reach of children and not in the vicinity of the refrigerating appliance, in order to prevent children from being locked inside.

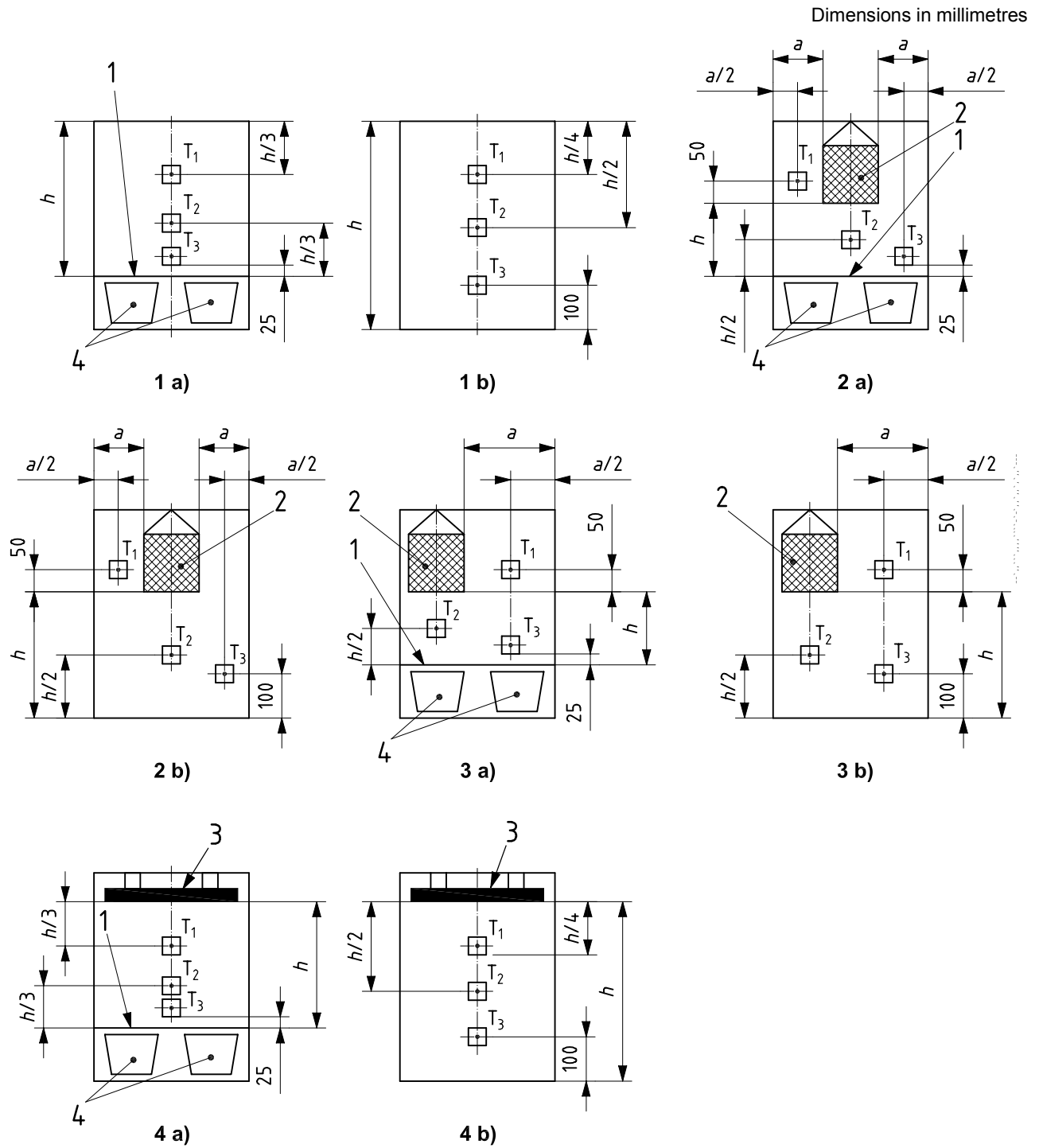

For arrangements 2 a), 2 b), 3 a), 3 b): $a \geq 150$ mm

Figure 14 — Temperature measurement points in fresh-food storage compartments with different arrangements of evaporator

Dimensions in millimetres

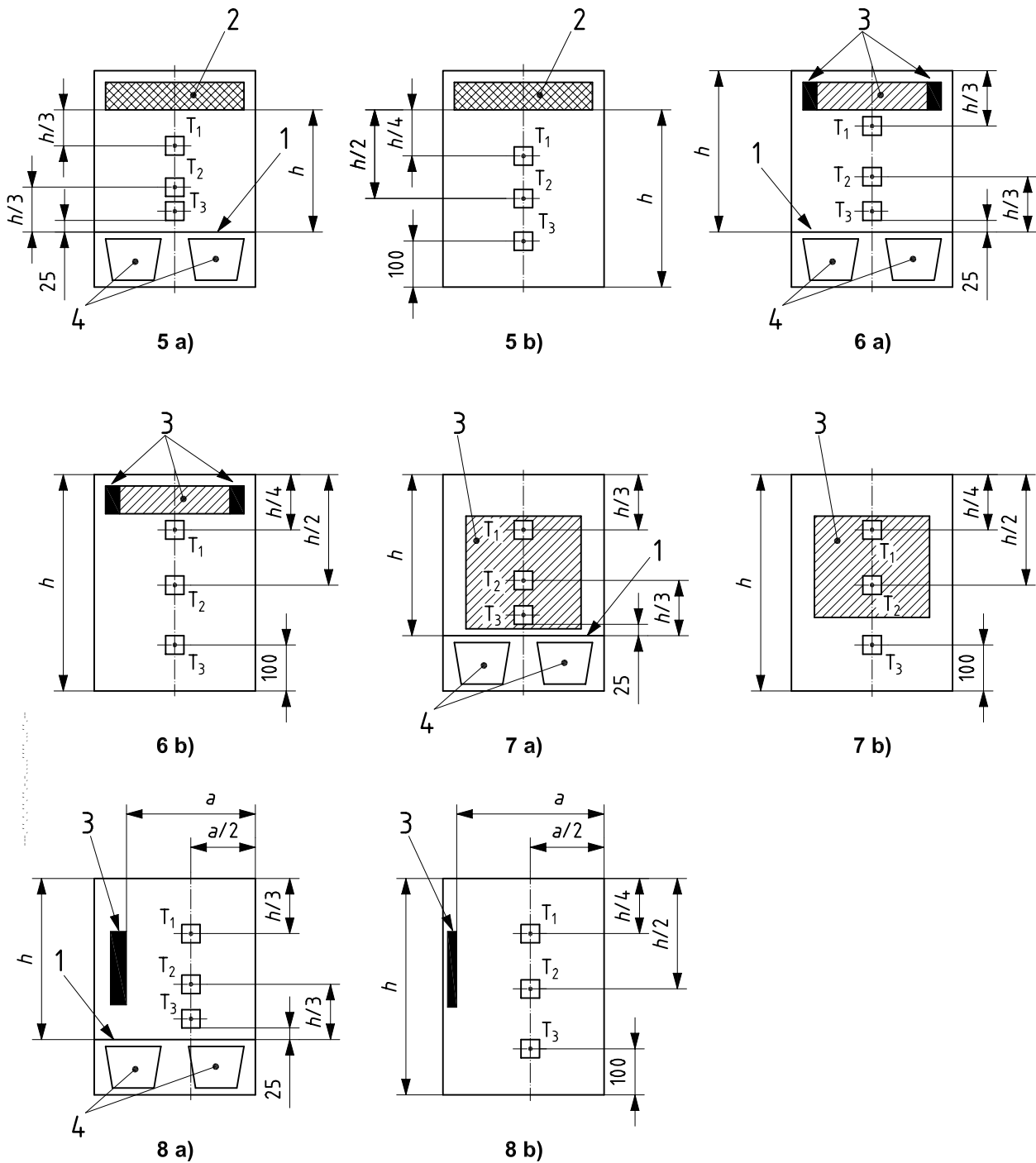

Key

- 1 shelf above vegetable container at lowest possible position
- 2 box evaporator
- 3 plate evaporator
- 4 vegetable container

Figure 14 — Temperature measurement points in fresh-food storage compartments with different arrangements of evaporator (continued)

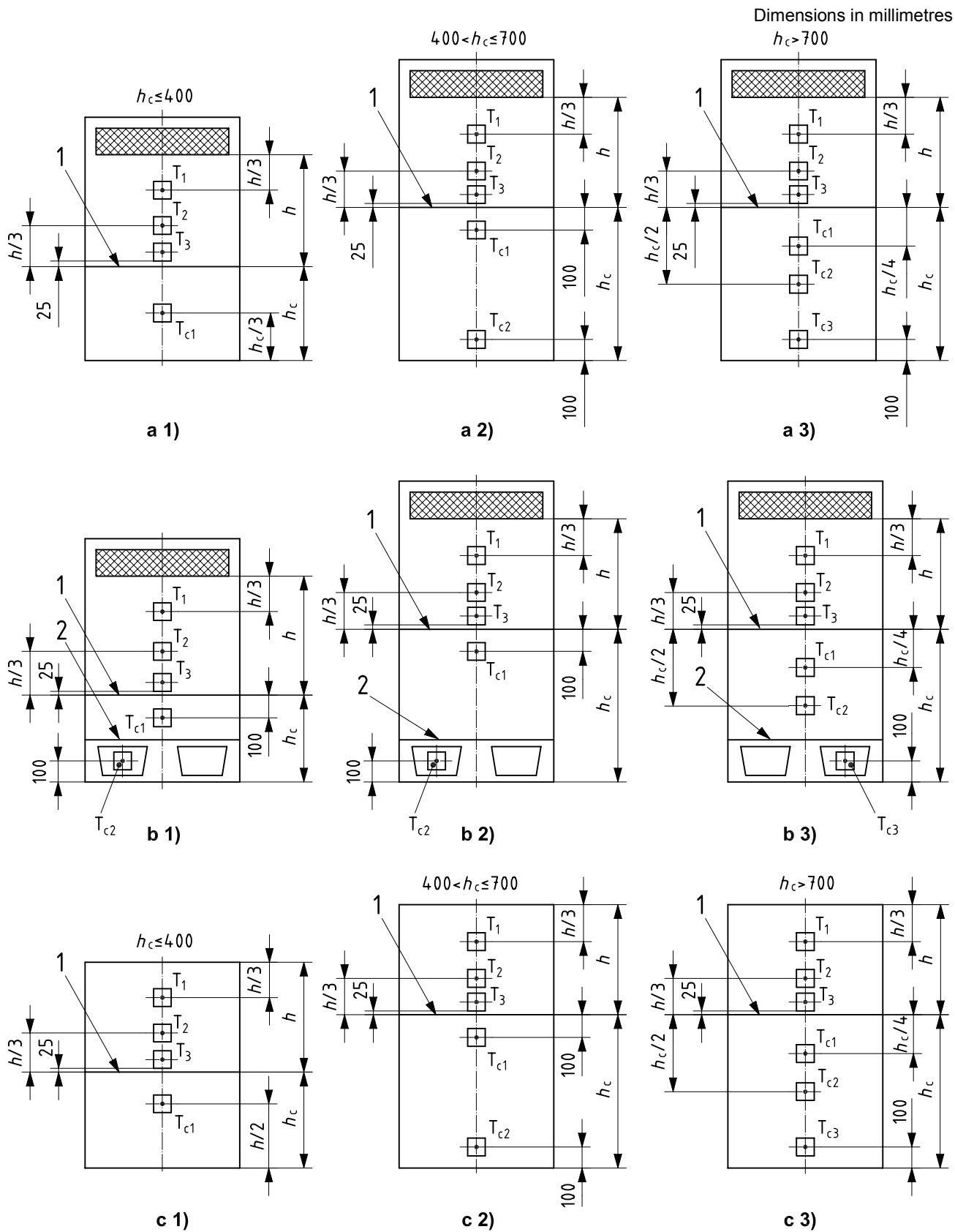

Figure 15 — Temperature measurement points T_{ci} in cellar compartments of refrigerators relative to height h_c and internal fittings

T₃ shall be 25 mm above a separator to the cellar compartment.

Key

- 1 separator for cellar compartment
- 2 shelf above vegetable container at lowest possible position

NOTE The arrangements for cellar compartment also apply to appliances that consist of just a cellar compartment. For different evaporators arrangements in the fresh food compartment, see also Figures 14 and 13.

Figure 15 — Temperature measurement points T_{c*i*} in cellar compartments of refrigerators relative to height h_c and internal fittings (*continued*)

Dimensions in millimetres

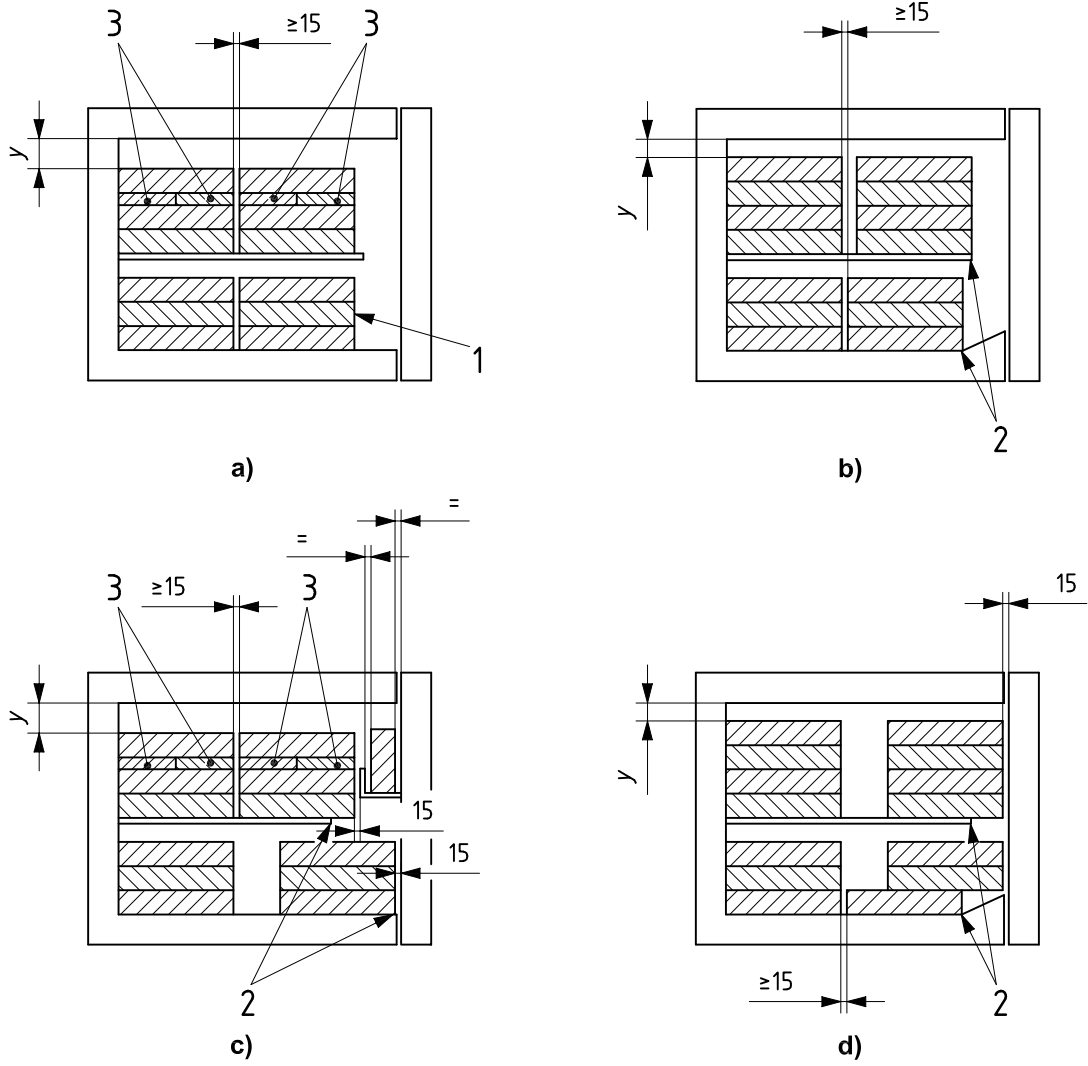

Side views

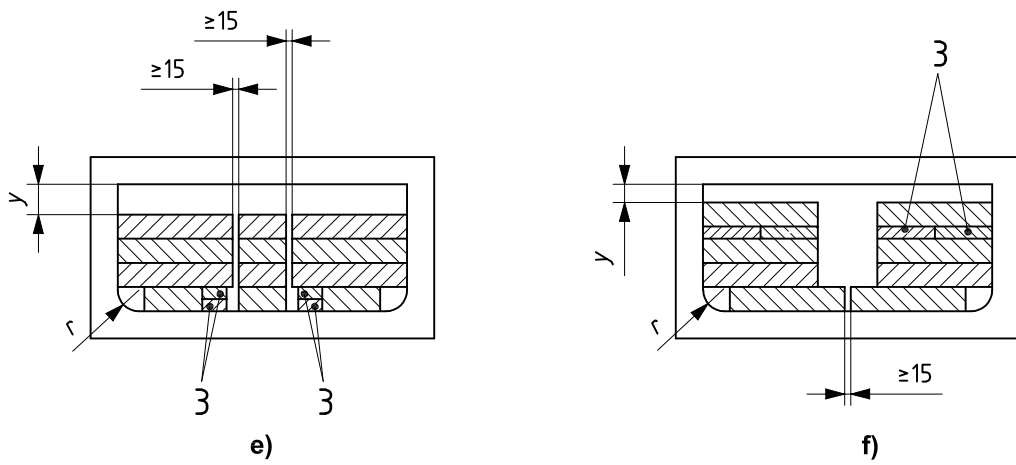

Front views with radiused corners

Figure 16 — Examples of storage plan (see 13.3)

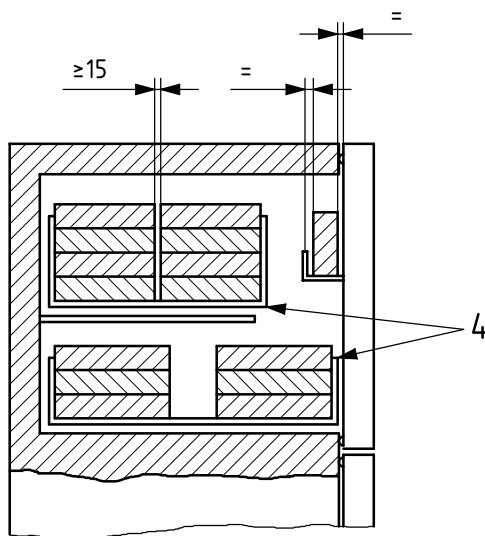

g)

Side view with containers

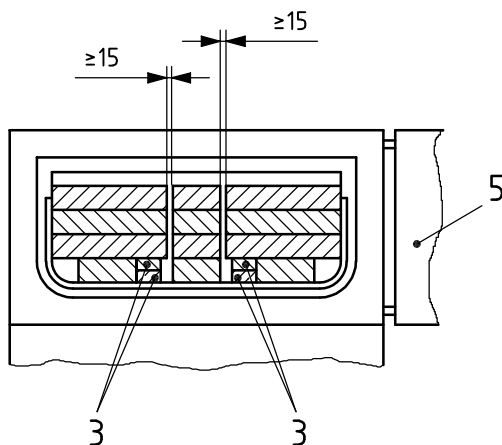

h)

Front view, containers with radiused corners

Key

- r* radiused
- y* vertical clearance between upper edge of highest package and inner surface of lid, shelf or horizontal surface situated immediately above: $10 > y < 35$ (see 13.3.2.4)
- 1 marked load-limit line
- 2 natural load limit
- 3 125-g packages
- 4 containers
- 5 door

Figure 16 — Examples of storage plan (see 13.3) (continued)

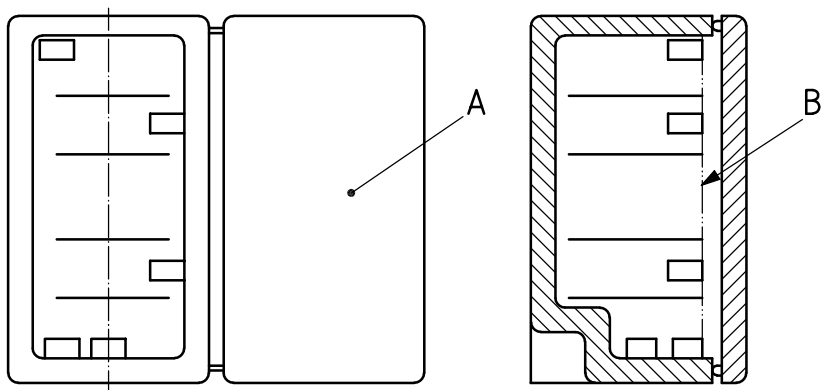

Front view, door open

Side cross-sectional view

a) Freezer or three-star cabinet — Without door storage; with n shelves; with marked load-limit line

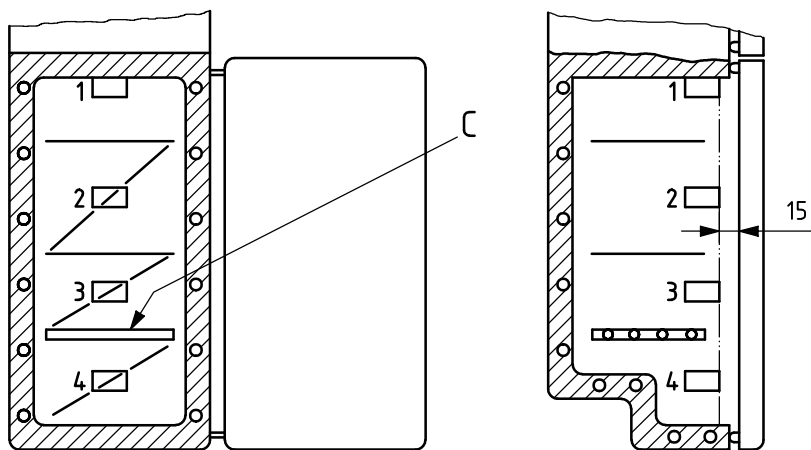

Front view, door open

Side cross-sectional view

b) Food freezer or frozen-food storage compartment — Without unventilated, refrigerated walls or bottom; without door storage; with n shelves; with natural load limit

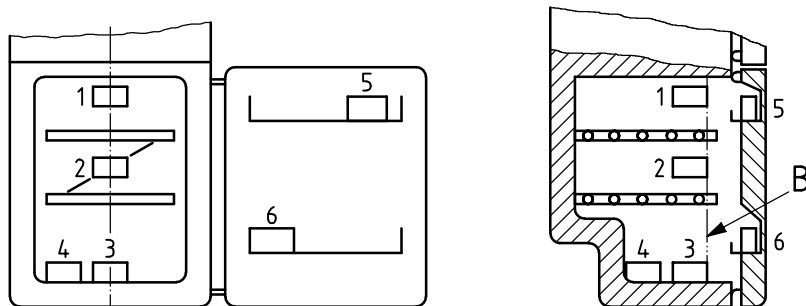

Front view, door open

Side cross-sectional view

c) Food freezer compartment or frozen-food storage compartment — Without visible evaporator; with door storage; with n refrigerated shelves; with marked load-limit line

Figure 17 — Examples of positioning of M-packages

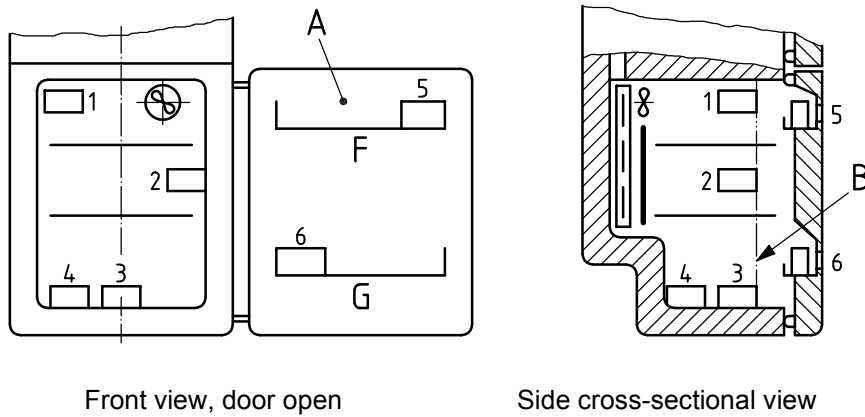

d) Food freezer compartment or frozen-food storage compartment — With door storage, n refrigerated shelves, and marked load-limit line

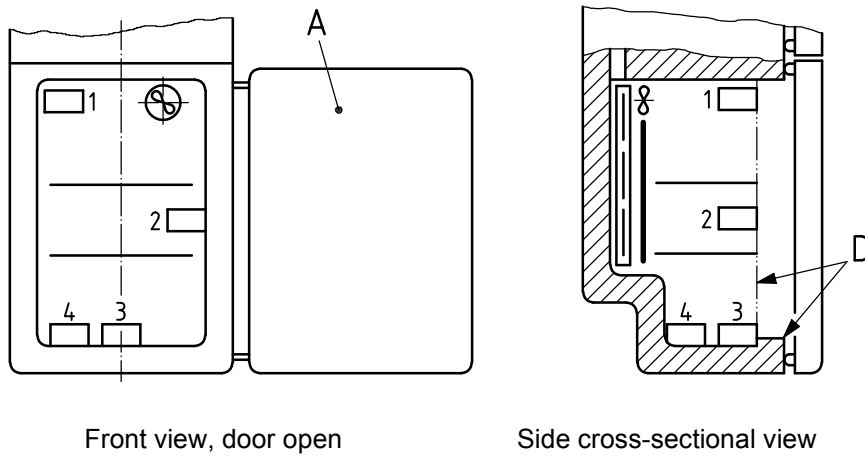

e) Food freezer compartment or frozen-food storage compartment — With door storage, n shelves, and natural load limit

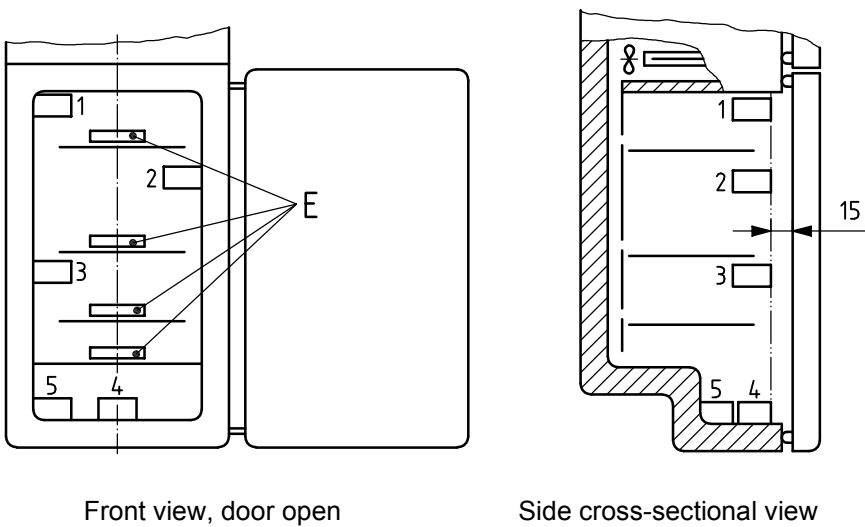

f) Food storage compartment — With door storage; with n shelves; without any marked load-limit line or natural load limit

Figure 17 — Examples of positioning of M-packages (continued)

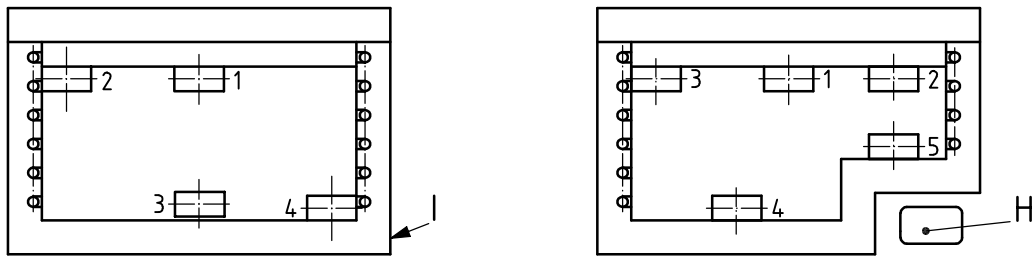

Front cross-sectional views

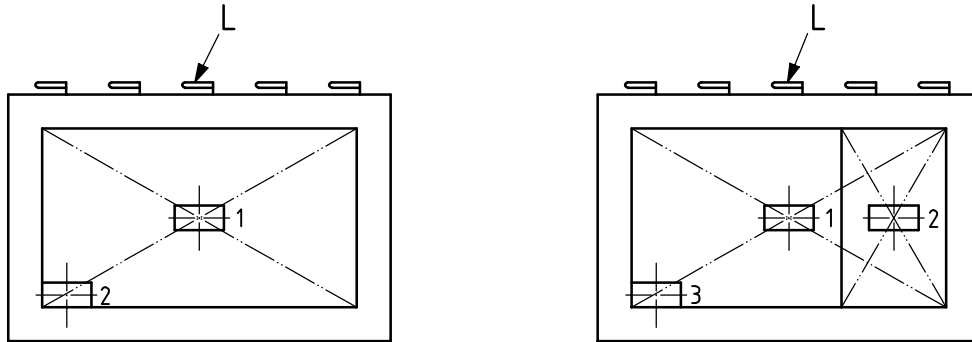

Plan views at level of load-limit line

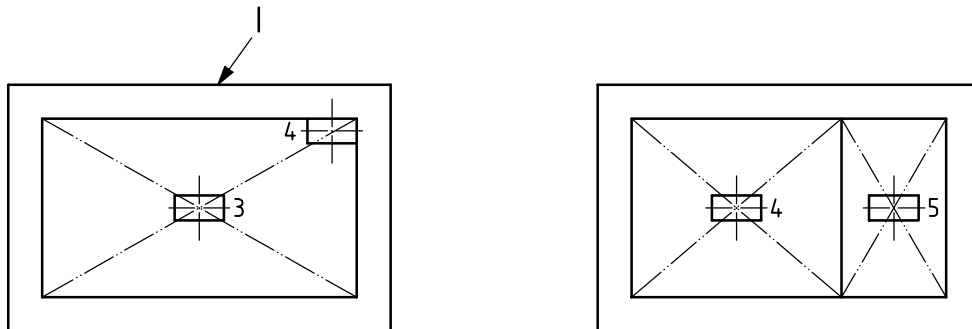

Plan views at the bottom

**g) Top-opening refrigerating appliance —
With refrigerated walls and without inner
partition**

**h) Top-opening type appliance —
With refrigerated walls and non-refrigerated inner
partition**

Key

- | | |
|--------------------------|--------------------|
| A door | F top shelf |
| B marked load-limit line | G bottom shelf |
| C refrigerated shelf | H motor compressor |
| D natural load limit | I compressor side |
| E ventilating openings | L hinges |

Figure 17 — Examples of positioning of M-packages (continued)

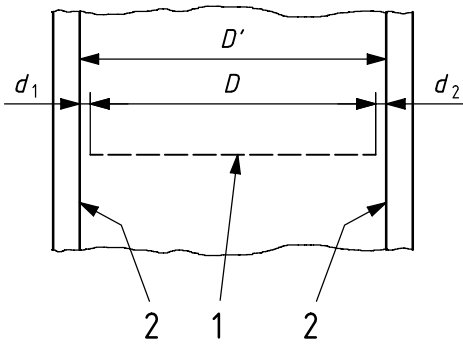

If $d_1 + d_2 \leq 20$ mm:
 dimension of shelf = D'
 If $d_1 + d_2 > 20$ mm:
 dimension of shelf = D

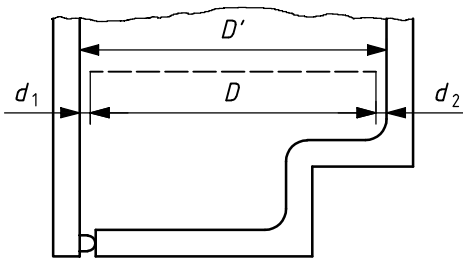

If $d_1 + d_2 \leq 20$ mm:
 dimension of shelf = D'
 If $d_1 + d_2 > 20$ mm:
 dimension of shelf = DD

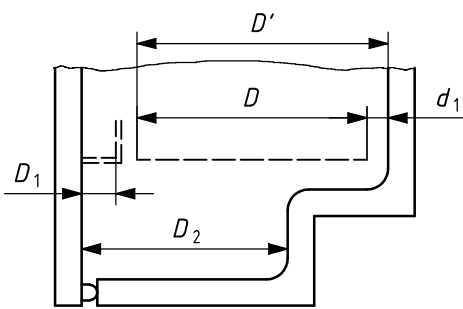

If $d_1 \leq 20$ mm:
 dimension of shelf = D'
 If $d_1 > 20$ mm:
 dimension of shelf = D
 Dimension of door shelf = D_1
 Dimension of bottom of refrigerating appliance = D_2

Upright-type refrigerating appliances

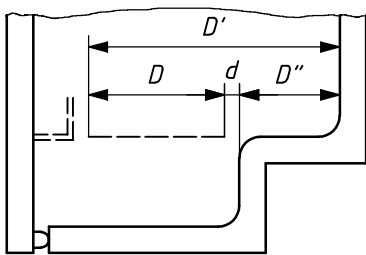

If $d \leq 20$ mm:
 dimension of shelf = D'
 If $d > 20$ mm:
 2 shelves of dimensions D and D''

Shelf with juxtaposed parts

a) Determination of depth

Figure 18 — Examples of determination of the dimensions for calculating shelf area (see 7.3)

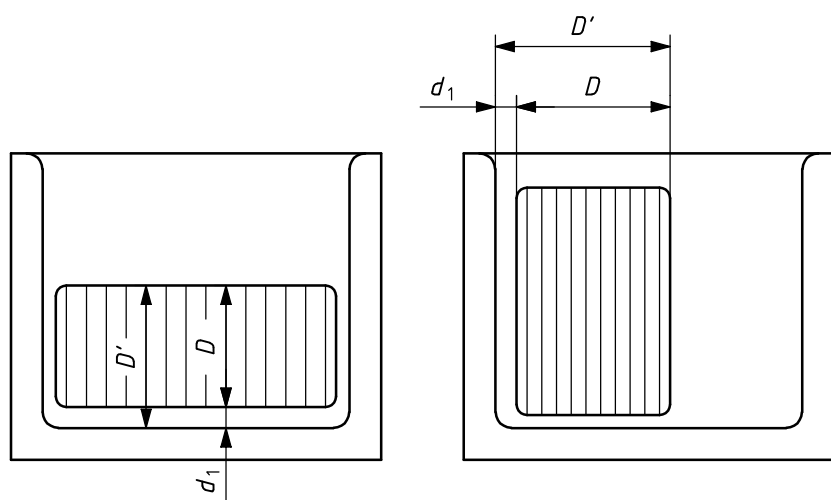

If $d \leq 20$ mm:
 dimension of the shelf = D'
 If $d > 20$ mm:
 Dimension of the shelf = D

b) Determination of dimensions of fractional shelves

Key

- 1 shelf
- 2 inner wall

Figure 18 — Examples of determination of the dimensions for calculating shelf area (see 7.3) (continued)

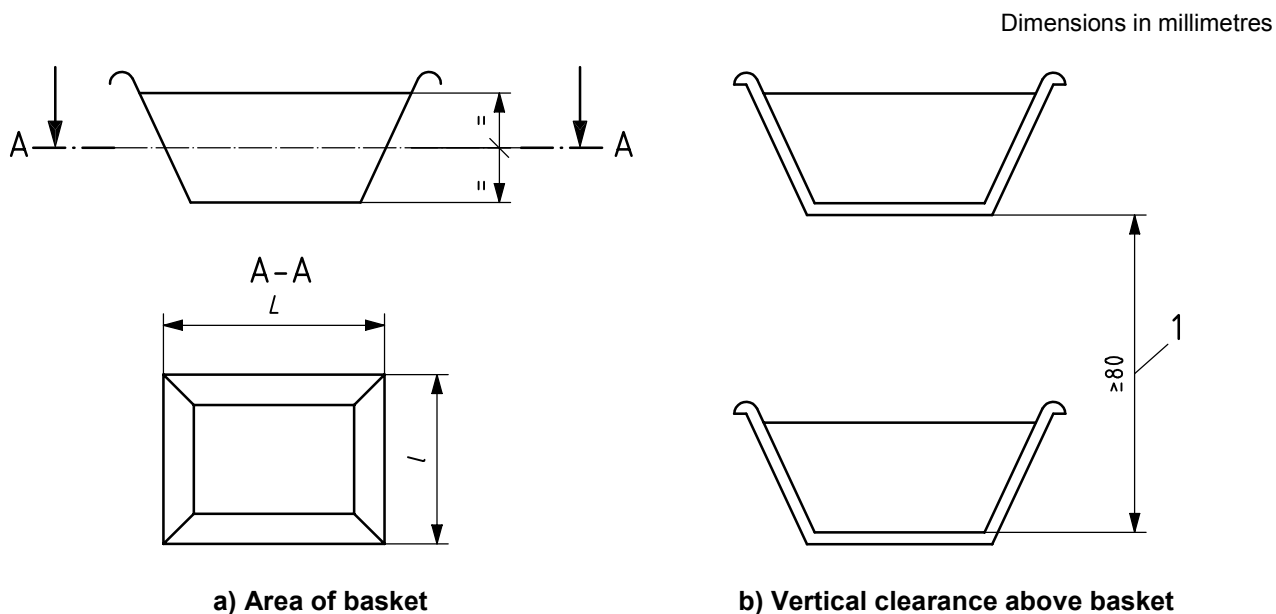

Dimensions in millimetres

a) Area of basket

b) Vertical clearance above basket

Key

- 1 ≥ 52 mm^a
- ^a Applicable for any frozen-food storage compartment.

Figure 19 — Examples of determination of mean dimensions for calculating the area of a basket (see 7.3.2.6, 7.3.2.7.2 and 7.3.2.7.3)

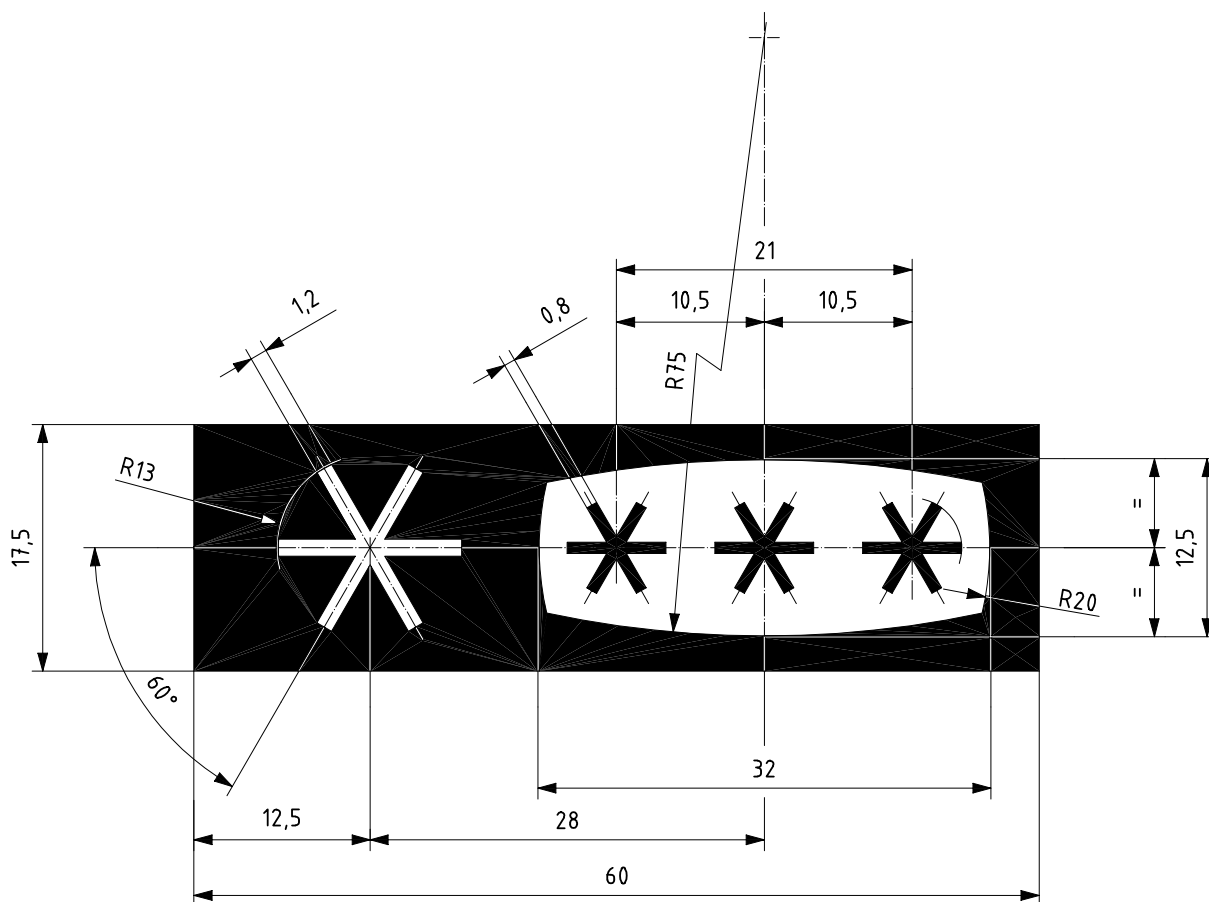

Dimensions are given for information; they may be reduced, while maintaining the same proportions, but the symbol height shall not be less than 5 mm (see ISO 7000).

Figure 20 — Details of identification symbols for food freezer compartments

Dimensions in millimetres

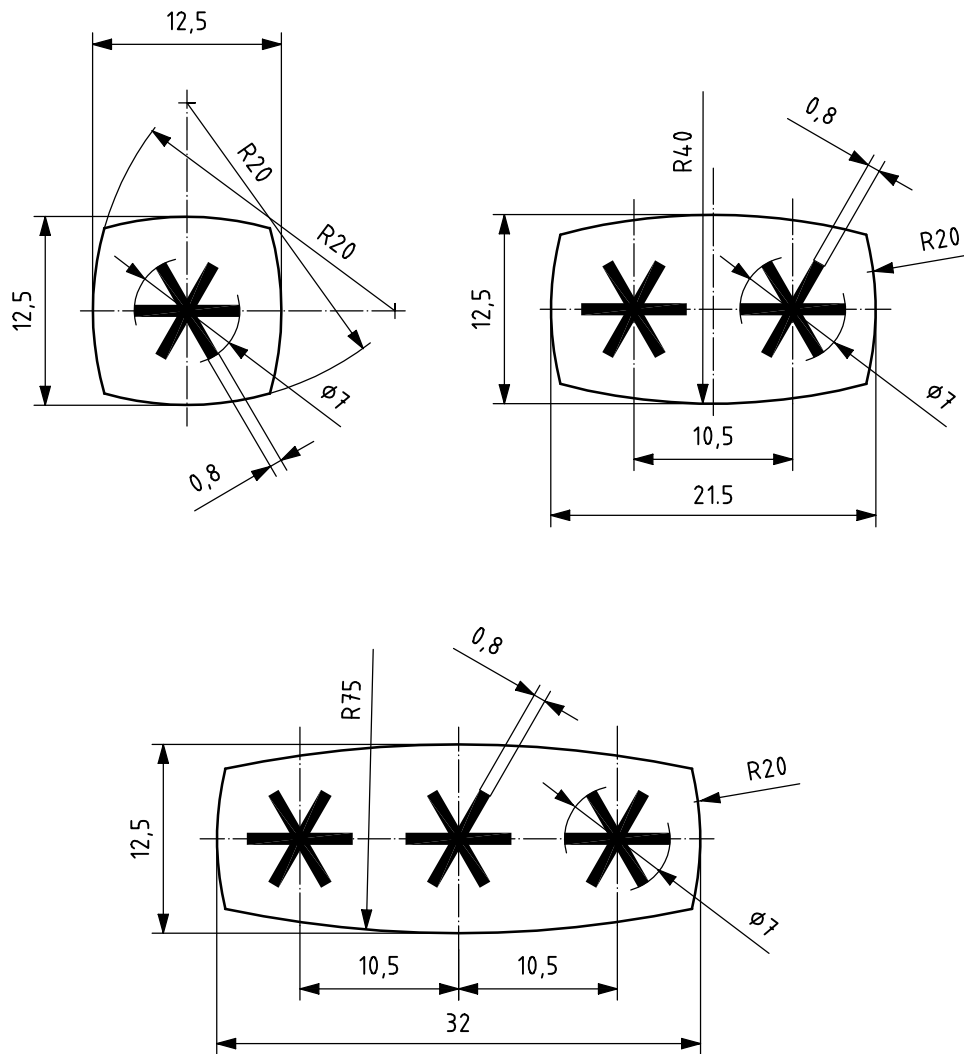

Dimensions are given for information; they may be reduced, while maintaining the same proportions, but the symbol height shall not be less than 5 mm.

Figure 21 — Details of identification symbols for frozen-food storage compartments

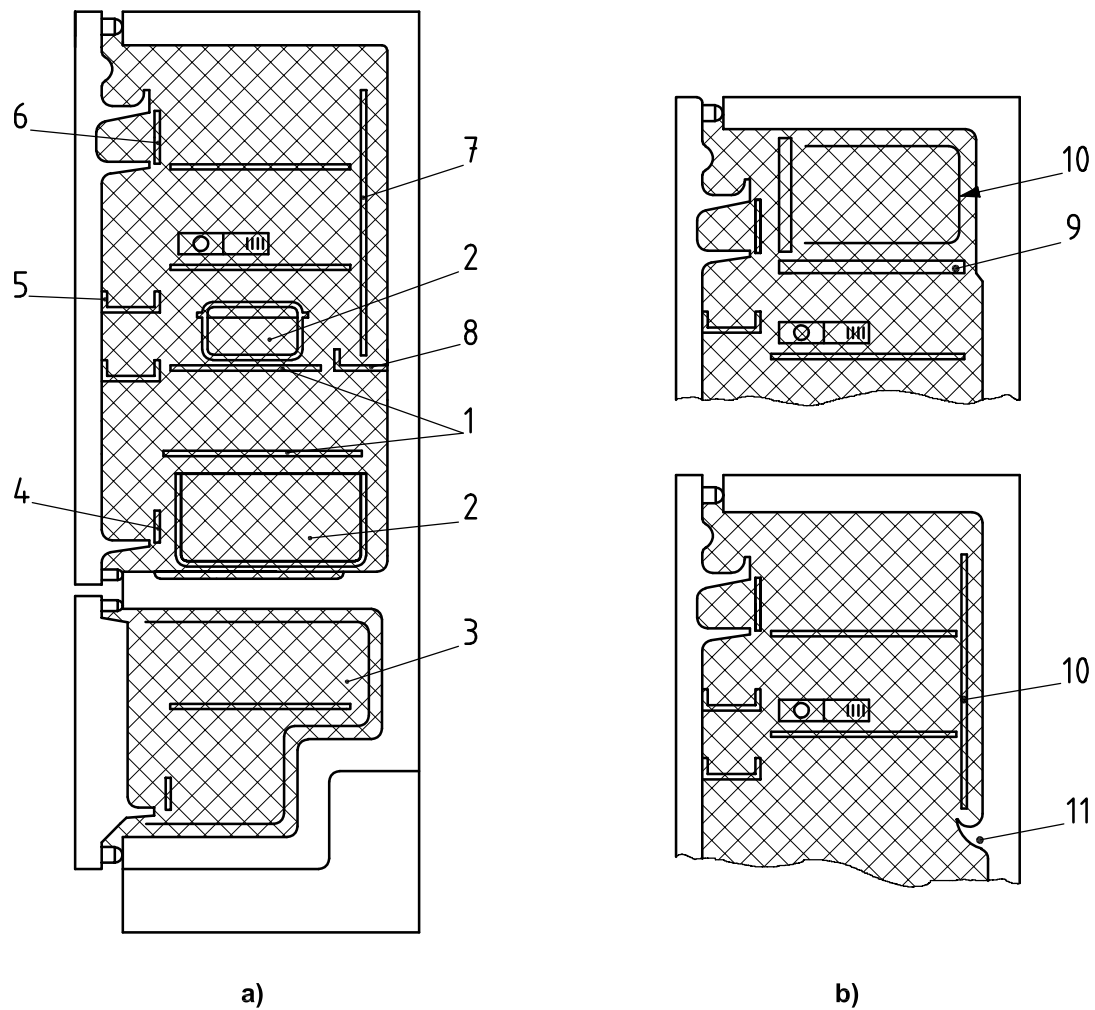
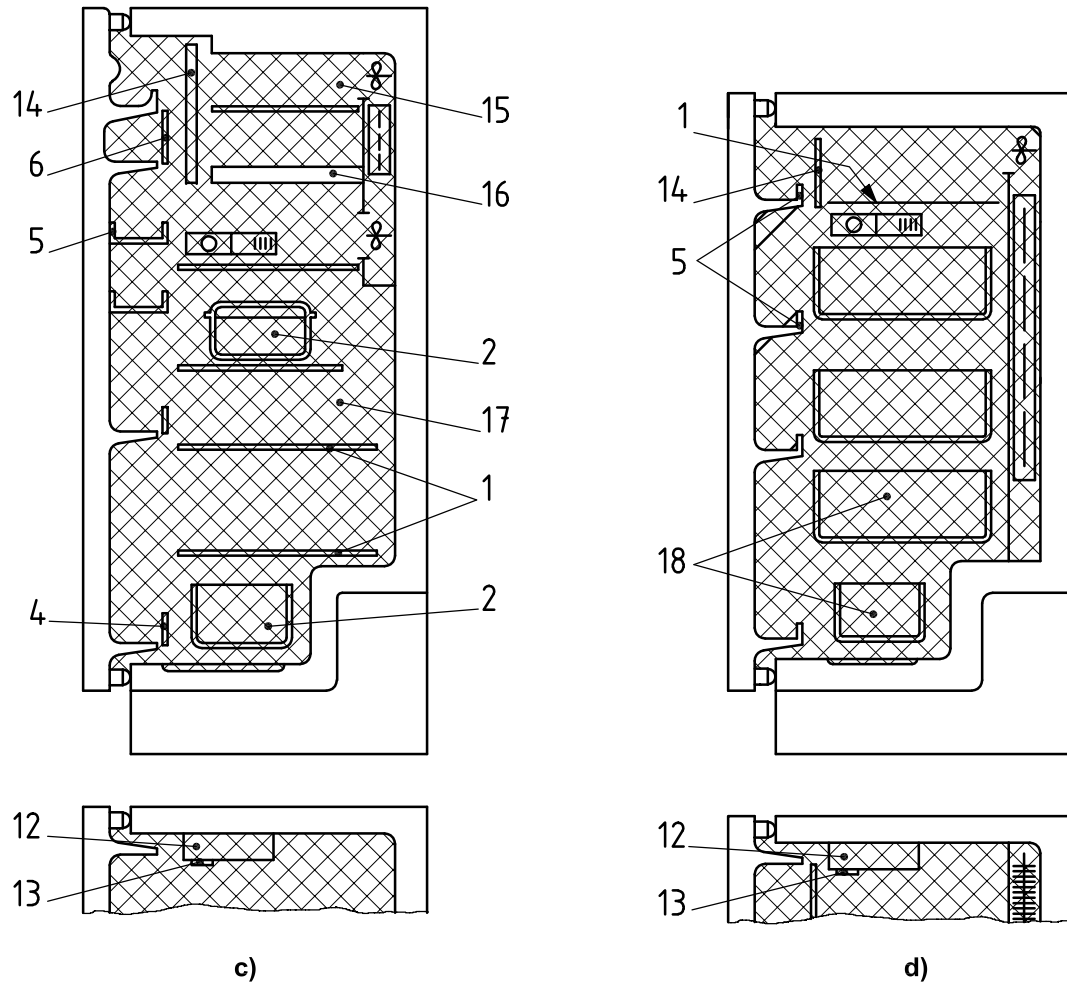

Figure 22 — Examples of determination of gross volume



Key

- | | |
|---|---|
| 1 shelves | 10 evaporator |
| 2 container | 11 drip-tray [if separate part, example a) only] |
| 3 frozen-food storage compartment evaporator | 12 temperature control device and (or) interior light housing |
| 4 retainer bar | 13 temperature control device knob |
| 5 door container or shelf | 14 door or flap |
| 6 flap | 15 low-temperature or food freezer compartment |
| 7 fresh-food storage compartment evaporator | 16 partition |
| 8 drip-tray [if not separate part, example a) only] | 17 fresh-food storage compartment |
| 9 drip-tray as separate part | 18 basket or container |

Figure 22 — Examples of determination of gross volume (continued)

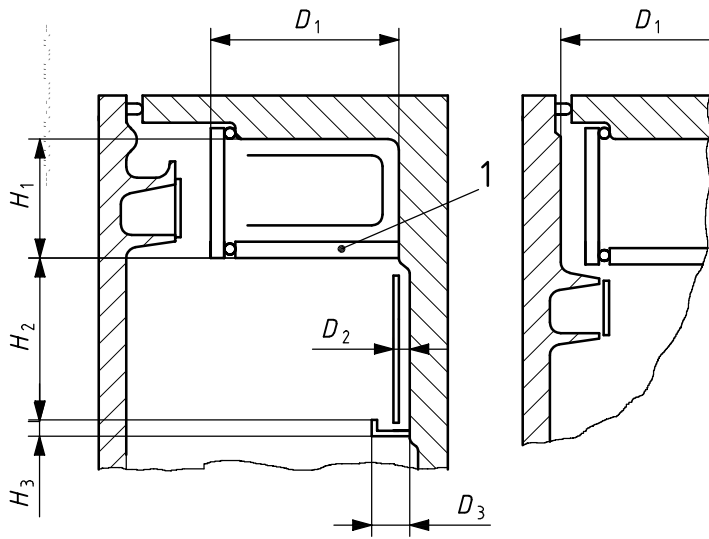

Volume to be calculated:

$$V = (D_1 \times H_1 \times W_1) + (D_2 \times H_2 \times W_2) + (D_3 \times H_3 \times W_3)$$

where

W_1 is equal to the width of food freezer or low-temperature compartment evaporator space;

W_2 is equal to the width of fresh-food storage compartment evaporator space;

W_3 is equal to the width of drip-tray evaporator space

Partition as separate part

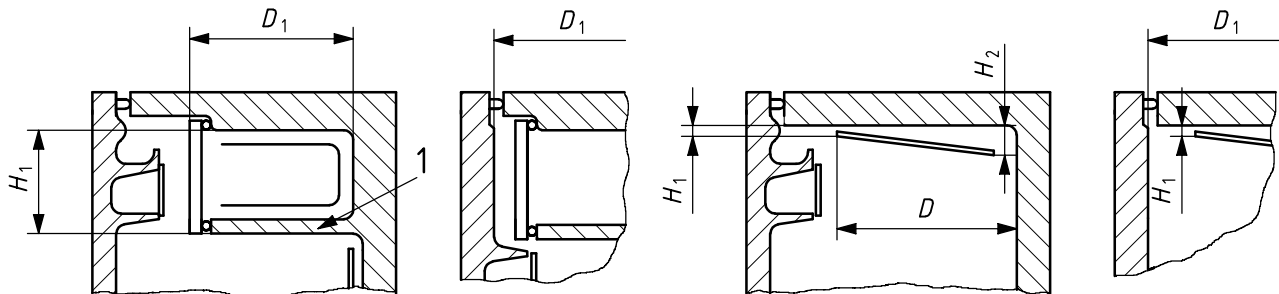

$$H_1 + H_2$$

$$V = D \times \frac{xW}{2}$$

Partition *not* as separate part

If $h_1, h_2 \leq 40$ mm:

$$V = D \times H_1 \times W$$

If $h_1 > 40$ mm, $h_2 \leq 40$ mm:

$$V = D \times (H_2 + h_3) \times W$$

If $h_2 > 40$ mm, and a definite manual operation is needed to initiate defrosting, $h_1 \leq 40$ mm:

$$V = D \times (H_2 + h_1) \times W$$

If $h_2 > 40$ mm, and a definite manual operation is needed to initiate defrosting, $h_1 > 40$ mm:

$$V = D \times H_2 \times W$$

NOTE See final example for W .

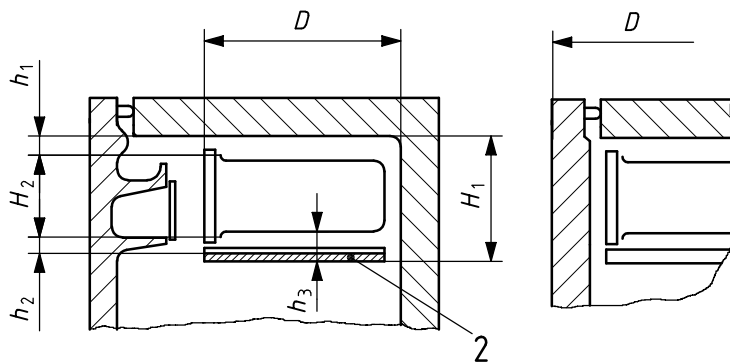

Box evaporator with drip tray

Figure 23 — Determination of volume of evaporator space

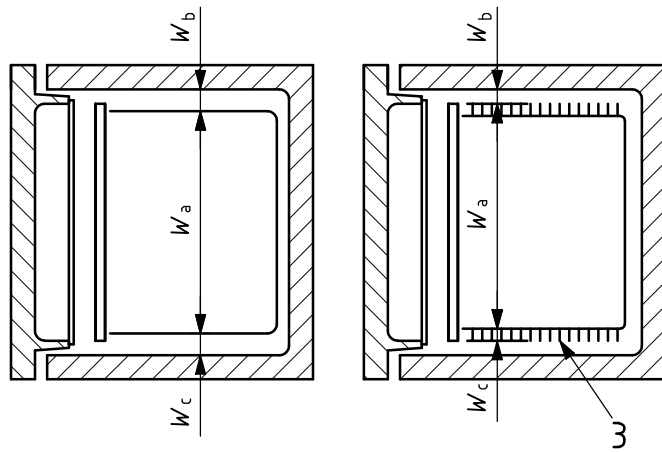

If $W_b, W_c < 70$ mm:

$$W = W_a + W_b + W_c$$

If $W_b < 70$ mm, $W_c \geq 70$ mm:

$$W = W_a + W_b$$

If $W_b, W_c \geq 7$ mm:

$$W = W_a$$

Determination of width (plan view)

Key

- 1 partition
- 2 drip tray
- 3 ribs

Figure 23 — Determination of volume of evaporator space (continued)

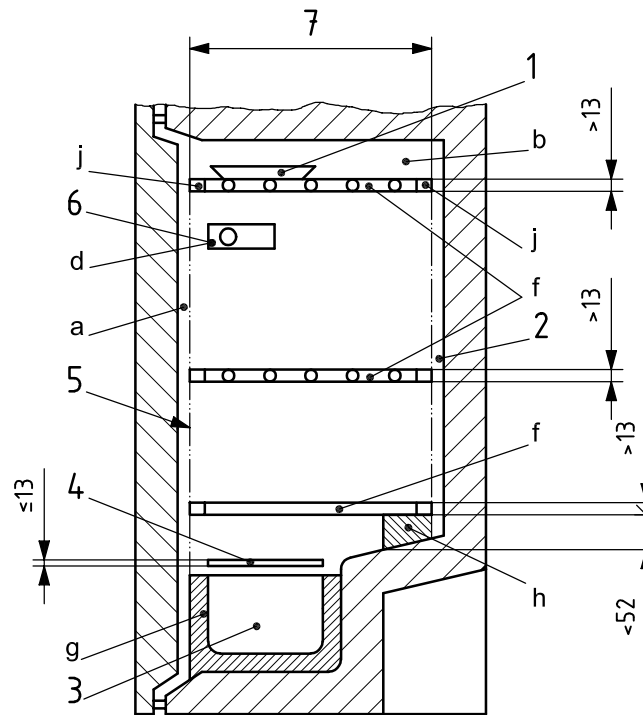

The volumes marked a, b, d, f, g, h and j shall be deducted from the gross volume. See 7.2.7.

Key

- 1 ice tray(s)
- 2 air duct
- 3 basket or container necessary for obtaining satisfactory thermal and mechanical characteristics
- 4 shelf
- 5 load limit
- 6 temperature-control device
- 7 shelf dimension

Figure 24 — Example of determination of storage volume of frozen-food storage or food freezer compartments/cabinets

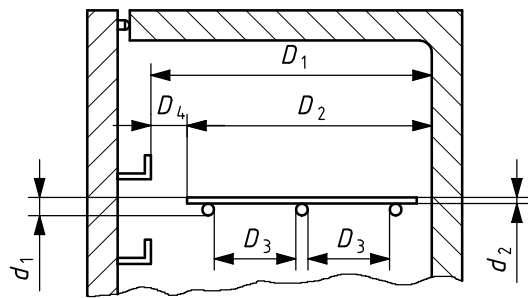

Side cross-sectional view

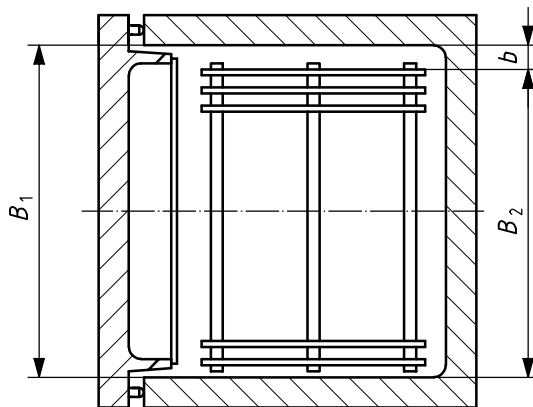

Top cross-sectional view

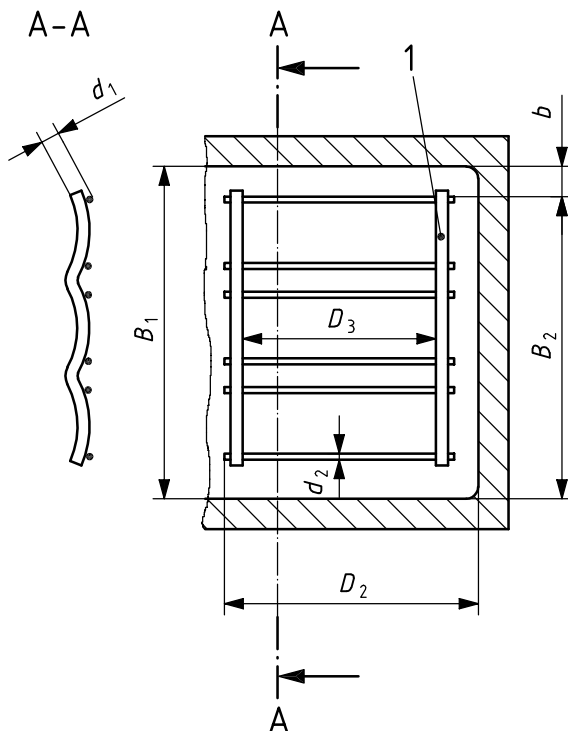

Top cross-sectional view

Key

- 1 bottle shelf

Conditions	Volume to be deducted
1) d_1 and $d_2 \leq 13$ mm	0
2) $d_1 > 13$ mm $d_2 \leq 13$ mm $D_3 > 100$ mm	0
3) $d_1 > 13$ mm $d_2 \leq d_1$ $D_3 \leq 100$ mm $D_4 \leq 70$ mm $b \leq 70$ mm	$d_1 \times D_1 \times B_1$
4) $d_1 > 13$ mm $d_2 \leq d_1$ $D_3 \leq 100$ mm $D_4 > 70$ mm $b \leq 70$ mm	$d_1 \times D_2 \times B_1$
5) $d_2 > 13$ mm $D_3 > 100$ mm $D_4 \leq 70$ mm $b \leq 70$ mm	$d_2 \times D_1 \times B_1$
6) $d_2 > 13$ mm $D_3 > 100$ mm $D_4 > 70$ mm $b \leq 70$ mm	$d_2 \times D_2 \times B_1$
7) if $b > 70$ mm, take B_2 instead of B_1 fractional shelf	

Figure 25 – Determination of volumes of shelves and partitions

Annex A (informative)

Conditions particular to certain countries

A.1 General

In some countries, owing to national regulations, special conditions exist additional to the provisions of this International Standard. The following have been identified.

A.2 France

A.2.1 Symbol identifying cold zone of compartment intended for storage of fresh food

The storage part of the compartment for the storage of fresh food, in which an average temperature not greater than + 4 °C can be maintained, shall be identified by an easily readable symbol, as shown in Figure A.1. The symbol may be marked in relief on the wall of cabinet.

An explanation of this symbol shall be included in instructions for users.

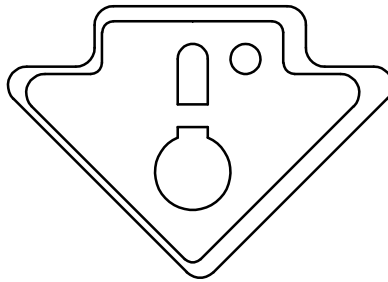

Figure A.1 — Cold zone identification symbol

A.2.2 Characteristics of thermometer or temperature indicator

Any thermometer or other device intended to indicate when the temperature measured in the cold zone of the refrigerators for domestic use is not greater than + 4 °C, shall be in accordance with the following conditions.

- a) It shall not contain any mercury.
- b) The measurement range shall extend from – 2 °C to + 15 °C.
- c) The grade shall not exceed 0,5 °C.
- d) The maximal tolerated error, in addition or in deduction, shall be equal to 1 °C for the interval of temperature indicated in b).
- e) There shall be an inertia of measure of a minimum of 30 s.
- f) Information shall be given relative to the instructions to users and to the methods of measuring the temperatures, in particular the duration of the temperature measurement.

- g) Devices intended to indicate that the temperature is not greater than + 4 °C, with binary indicator, shall meet the requirements of a) and d) to f).

A.3 Japan

In respect of Table 2, a storage temperature of the chill compartment of $-3 \leq t_{cc} \leq +3$ is required.

Annex B (informative)

Percentage running time

B.1 General

Under given conditions of ambient temperature and of internal storage temperature, the percentage running time ratio, R , is expressed by

$$R = \frac{d}{D} \times 100$$

where

- d is the duration of the refrigerating system operation during a whole number of operating cycles (see 3.6.15);
- D is the total duration of the cycles [frost-free systems, D is the total duration of the cycle minus the duration of the automatic defrosting cycle (see 3.6.21), even if defrosting occurs by a hot-gas system (see Figure 1)].

In the case of a refrigerating appliance having two independent refrigerating systems, there will be two values for percentage running time — one for the fresh-food storage compartment and one for the low-temperature compartment.

For refrigerating appliances with a hot-gas defrosting system, the time required for hot-gas defrosting shall not be included in the running time of the refrigerating unit.

B.2 Measurement of percentage running time

B.2.1 General

When a refrigerating appliance cycles “on/off” when operating under the conditions specified in 8.7, at a given ambient temperature, the running time shall be measured during a test period not less than 3 h of stable running and a whole number of complete compressor cycles.

B.2.2 Electrically driven refrigerating appliances

Use may be made of a synchronous clock that operates when the refrigerating system is running. When the current relay, inserted in series in the power supply circuit, is energized by the current flowing through it, it applies the voltage to the synchronous clock whose reading is recorded at the beginning and the end of the test. Running time is the difference between the two readings.

Alternatively, either the current or power may be plotted against time from a recording ammeter or wattmeter, and the running and idle periods computed from the graph.

B.2.3 Non-electrically driven refrigerating appliances

Any suitable device may be used to record the running time of the refrigerating system.

Annex C (informative)

Test for absence of taste and odour

C.1 Purpose

The purpose of this test is to check that materials used for the internal components of the fresh-food storage compartments, and chill and cellar compartments, if any, will not impart either taste or odour to food.

C.2 Procedure

C.2.1 Ambient temperature

The ambient temperature shall be between + 16 °C and + 32 °C.

C.2.2 Cleaning

The refrigerating appliance shall be cleaned prior to the test in accordance with the manufacturer's instructions and afterwards with pure water.

C.2.3 Temperature-control device setting

The refrigerating appliance shall first be operated for 48 h, with the temperature-control device and other control devices set in a position which will give the following temperatures.

- Fresh-food storage compartment: $t_{am} = + 5 \text{ °C} \pm 2 \text{ K}$
- Cellar compartment: $+ 8 \text{ °C} \leq t_{cma} \leq + 14 \text{ °C}$
- Chill compartment: $- 2 \text{ °C} \leq t_{cc} \leq + 3 \text{ °C}$

C.2.4 Samples

The analytical samples and check samples, respectively, for each compartment shall be

- a) 100 ml potable water, and
- b) a slice of fresh unsalted butter of dimensions 75 mm × 35 mm × 5 mm.

From each of a) and b) above, at least six samples are necessary to serve as analytical samples and at least six to serve as check samples.

The analytical samples shall be placed in Petri dishes and the check samples in glass containers, the latter being hermetically sealed.

Prior to the test, all Petri dishes and containers used for the test shall be cleaned with fuming nitric acid and subsequently washed with distilled water until the complete absence of odour is obtained.

ISO 15502:2005(E)

The analytical samples of water and butter shall be placed uncovered in the fresh-food storage, chill and cellar compartments.

The check samples, in the hermetically sealed glass containers, shall be placed close to the analytical samples.

C.2.5 Test period

The analytical samples and the check samples shall be left in the operating refrigerating appliance with the door(s) closed and at the specified temperature conditions for 48 h. After 48 h, the analytical samples shall be covered.

Then the analytical samples and check samples shall be removed and warmed up to approximately 20 °C by leaving them in the test room.

C.3 Examination of samples

C.3.1 Conditions

Examination shall be made about 2 h after removal of the samples from the refrigerating appliance and shall be carried out by at least three expert assessors familiar with the test method.

Each expert assessor shall receive

- two analytical samples of water,
- two check samples of water,
- two analytical samples of butter, and
- two check samples of butter.

The identity of the samples shall not be made known to the expert assessors. Examination for odour shall be carried out before examination for taste.

The samples of water shall be examined prior to the samples of butter, unless a separate examination by different expert assessors takes places.

The examiners shall record their remarks, independently of each other, in writing.

C.3.2 Evaluation

The evaluation of the analytical samples shall be carried out with reference to the following scale.

Mark 0	No foreign odour or foreign taste
Mark 1	Slight foreign odour or foreign taste
Mark 2	Definitely perceptible foreign odour or foreign taste
Mark 3	Distinct foreign odour or foreign taste

If the evaluation of the first test exceeds Mark 1, the test shall be repeated. The following provisions shall be made for the second test:

- a) defrosting of the refrigerating appliance;
- b) cleaning of the compartments;
- c) operation of the empty refrigerating appliance for one week;
- d) defrosting of the refrigerating appliance and cleaning of the compartments;
- e) temperature adjustment in the fresh-food storage, chill and cellar compartment for the second test for absence of odour and taste.

C.4 Test report

The test report shall indicate the evaluation.

Annex D (normative)

Built-in refrigerating appliances

Refrigerating appliances intended only for building-in or for placing under a counter or under a worktop, or between cabinets (under-counter types), shall be built-in or placed in a test enclosure of dull black-painted, approximately 20 mm thick, plywood. If a manufacturer requires a fascia door, it shall be fitted.

The inner dimensions of the test enclosure shall comply with the manufacturer's instructions.

If a range of dimensions are given, then the smallest values shall be used.

If this data is not given, the inner dimensions of the test enclosure shall be as follows:

- the inner depth shall exceed by 20 mm to 50 mm the overall depth of the refrigerating appliance, and shall not be more than 550 mm;
- the inner width shall exceed by 4 mm to 6 mm the overall width of the refrigerating appliance;
- the inner height shall exceed by 2 mm to 4 mm the overall height of the refrigerating appliance.

If necessary, the test enclosure shall be provided with ventilating openings according to the manufacturer's instructions.

The refrigerating appliance shall be built-in or placed in the test enclosure according to the manufacturer's instructions such that only its door projects beyond the front edges of the enclosure.

If the refrigerating appliance is provided with spacers, strips or other special means of solid or resilient material for closing the gap between the contours of the refrigerating appliance and the cabinet or enclosure, these means shall be used accordingly. If such means are not provided, the gaps between the test enclosure and the refrigerating appliance shall be left open.

The back partition shall be in close contact with the side of the test enclosure such as to prevent unintended airflow.

NOTE This could require adhesive tape or sealing compound.

Annex E (informative)

Rated characteristics and control procedure

E.1 Volumes and areas

E.1.1 Rated gross volume

The measured value according to Clause 7 shall not be less than the rated value by more than 3 % or 1 l, whichever is the greater value.

E.1.2 Rated storage volume

The measured value according to Clause 7 shall not be less than the rated value by more than 3 % or 1 l, whichever is the greater value. Where the volumes of the cellar compartment and fresh-food storage compartment are adjustable relative to one another by the user, this requirement applies when the cellar compartment is adjusted to its minimum volume.

E.1.3 Rated storage shelf area

The measured storage shelf area according to Clause 7, including that of any cellar and chill compartment, shall not be less than the rated storage shelf area by more than 3 %.

E.1.4 Control procedure

If the requirements of E 1.1, E 1.2 or E 1.3 are not met on a single refrigerating appliance, the measurements shall be made on a further three, randomly selected, refrigerating appliances.

The arithmetical mean of the measured values of these three refrigerating appliances shall be in accordance with the requirements of E 1.1, E 1.2 or E 1.3.

E.2 Performance characteristics

E.2.1 Storage temperatures

The values measured in accordance with Clause 13 on the first refrigerating appliance tested shall comply with the requirements of Table 2.

If any result of the test carried out on the first refrigerating appliance is outside the specified values, the test shall be carried out on a further three, randomly selected, refrigerating appliances. All the values on these three refrigerating appliances tested shall comply with requirements given in Table 2.

E.2.2 Freezing capacity

The value measured in accordance with Clause 17 on the first refrigerating appliance tested shall be not less than the rated value by more than 15 %.

If the result of the test carried out on the first refrigerating appliance is less than the rated value minus 15 %, the test shall be carried out on a further three, randomly selected, refrigerating appliances.

The arithmetical mean of the values of these three refrigerating appliances shall be greater than or equal to the rated value minus 10 %.

The value obtained either on the first refrigerating appliance tested or the arithmetical mean value obtained on a further three refrigerating appliances shall be in accordance with the minimum values stated in Clause 17.

E.2.3 Energy consumption

The value measured shall not be greater than the rated value by more than 15 %.

If the result of the test carried out on the first refrigerating appliance is greater than the rated value plus 15 %, the test shall be carried out on a further three, randomly selected, refrigerating appliances. The arithmetical mean of the values of these three refrigerating appliances shall be less than or equal to the rated value plus 10 %.

E.2.4 Ice-making

The measured value shall not be less than the rated value by more than 15 %.

If the value obtained from the first test is less than the rated value minus 15 %, the test shall be carried out on a further three, randomly selected, refrigerating appliances. The arithmetical mean of the values of these three refrigerating appliances shall be greater than or equal to the rated value minus 10 % .

E.2.5 Temperature rise time

The measured value in accordance with Clause 16 shall not be shorter than the rated value by more than 15 %.

If the result of the test on the first refrigerating appliance is less than the rated value minus 15 % , the test shall be carried out on a further three, randomly selected, refrigerating appliances. The arithmetical mean of the values of these three refrigerating appliances shall be greater than or equal to the rated value minus 10 %.

Bibliography

- [1] ISO 3055:1985, *Kitchen equipment — Coordinating sizes*
- [2] ISO 5149:1993, *Mechanical refrigerating systems used for cooling and heating — Safety requirements*
- [3] ISO 7000:1989, *Graphical symbols for use on equipment — Index and synopsis*
- [4] IEC 60335-1:2001, *Safety of household and similar electrical appliances — Part 1: General requirements*
- [5] EN 153, *Methods of measuring the energy consumption of electric mains operated household refrigerators, frozen-food storage cabinets, food freezers and their combinations, together with associated characteristics*

www.iso.org

ICS 97.040.30

Price based on 81 pages