

---

---

**Road vehicles — Compressed natural  
gas (CNG) fuel system components —  
Part 2:  
Performance and general test methods**

*Véhicules routiers — Composants des systèmes de combustible gaz  
naturel comprimé (GNC) —*

*Partie 2: Performances et méthodes d'essai générales*



**COPYRIGHT PROTECTED DOCUMENT**

© ISO 2016, Published in Switzerland

All rights reserved. Unless otherwise specified, no part of this publication may be reproduced or utilized otherwise in any form or by any means, electronic or mechanical, including photocopying, or posting on the internet or an intranet, without prior written permission. Permission can be requested from either ISO at the address below or ISO's member body in the country of the requester.

ISO copyright office  
Ch. de Blandonnet 8 • CP 401  
CH-1214 Vernier, Geneva, Switzerland  
Tel. +41 22 749 01 11  
Fax +41 22 749 09 47  
copyright@iso.org  
www.iso.org

# Contents

	Page
Foreword .....	iv
Introduction .....	vi
<b>1 Scope</b> .....	<b>1</b>
<b>2 Normative references</b> .....	<b>1</b>
<b>3 Terms and definitions</b> .....	<b>1</b>
<b>4 General</b> .....	<b>1</b>
<b>5 Hydrostatic strength</b> .....	<b>2</b>
<b>6 Leakage</b> .....	<b>2</b>
6.1 General .....	2
6.2 External leakage .....	2
6.3 Internal leakage .....	3
6.4 Test conditions .....	3
<b>7 Excess torque resistance</b> .....	<b>3</b>
<b>8 Bending moment</b> .....	<b>4</b>
<b>9 Continued operation</b> .....	<b>5</b>
9.1 General .....	5
9.2 Test methods .....	5
9.2.1 Test procedure .....	5
9.2.2 Room temperature cycling .....	6
9.2.3 High-temperature cycling .....	6
9.2.4 Low-temperature cycling .....	6
<b>10 Corrosion resistance</b> .....	<b>6</b>
<b>11 Oxygen ageing</b> .....	<b>6</b>
<b>12 Electrical over-voltages</b> .....	<b>7</b>
<b>13 Non-metallic material immersion</b> .....	<b>7</b>
<b>14 Vibration resistance</b> .....	<b>8</b>
<b>15 Brass material compatibility</b> .....	<b>8</b>
<b>16 Ozone ageing for vulcanized or thermoplastic rubbers</b> .....	<b>8</b>
<b>17 Resistance to dry heat for vulcanized or thermoplastic rubbers</b> .....	<b>9</b>
<b>18 Automotive fluid exposure</b> .....	<b>9</b>
18.1 General .....	9
18.2 Test Method .....	9
18.3 Fluids .....	9
18.4 Pass criteria .....	9
<b>Bibliography</b> .....	<b>10</b>

## Foreword

ISO (the International Organization for Standardization) is a worldwide federation of national standards bodies (ISO member bodies). The work of preparing International Standards is normally carried out through ISO technical committees. Each member body interested in a subject for which a technical committee has been established has the right to be represented on that committee. International organizations, governmental and non-governmental, in liaison with ISO, also take part in the work. ISO collaborates closely with the International Electrotechnical Commission (IEC) on all matters of electrotechnical standardization.

The procedures used to develop this document and those intended for its further maintenance are described in the ISO/IEC Directives, Part 1. In particular the different approval criteria needed for the different types of ISO documents should be noted. This document was drafted in accordance with the editorial rules of the ISO/IEC Directives, Part 2 (see [www.iso.org/directives](http://www.iso.org/directives)).

Attention is drawn to the possibility that some of the elements of this document may be the subject of patent rights. ISO shall not be held responsible for identifying any or all such patent rights. Details of any patent rights identified during the development of the document will be in the Introduction and/or on the ISO list of patent declarations received (see [www.iso.org/patents](http://www.iso.org/patents)).

Any trade name used in this document is information given for the convenience of users and does not constitute an endorsement.

For an explanation on the meaning of ISO specific terms and expressions related to conformity assessment, as well as information about ISO's adherence to the World Trade Organization (WTO) principles in the Technical Barriers to Trade (TBT) see the following URL: [www.iso.org/iso/foreword.html](http://www.iso.org/iso/foreword.html).

The committee responsible for this document is ISO/TC 22, *Road vehicles*, Subcommittee SC 41, *Specific aspects for gaseous fuels*.

This third edition cancels and replaces the second edition (ISO 15500-2:2012), which has been technically revised.

ISO 15500 consists of the following parts, under the general title *Road vehicles — Compressed natural gas (CNG) fuel system components*:

- *Part 1: General requirements and definitions*
- *Part 2: Performance and general test methods*
- *Part 3: Check valve*
- *Part 4: Manual valve*
- *Part 5: Manual cylinder valve*
- *Part 6: Automatic valve*
- *Part 7: Gas injector*
- *Part 8: Pressure indicator*
- *Part 9: Pressure regulator*
- *Part 10: Gas-flow adjuster*
- *Part 11: Gas/air mixer*
- *Part 12: Pressure relief valve (PRV)*
- *Part 13: Pressure relief device (PRD)*

- *Part 14: Excess flow valve*
- *Part 15: Gas-tight housing and ventilation hose*
- *Part 16: Rigid fuel line in stainless steel*
- *Part 17: Flexible fuel line*
- *Part 18: Filter*
- *Part 19: Fittings*
- *Part 20: Rigid fuel line in material other than stainless steel*

## **Introduction**

For the purposes of this part of ISO 15500, all fuel system components in contact with natural gas have been considered suitable for natural gas as defined in ISO 15403 (all parts). However, it is recognized that miscellaneous components not specifically covered herein can be examined to meet the criteria of this part of ISO 15500 and can be tested in accordance with the appropriate functional tests.

All references to pressure in this part of ISO 15500 are considered to be gauge pressures unless otherwise specified.

This part of ISO 15500 is based on a service pressure for natural gas used as fuel of 20 MPa (200 bar<sup>1)</sup>), settled at 15 °C. Other service pressures can be accommodated by adjusting the pressure by the appropriate factor (ratio). For example, a 25 MPa (250 bar) service pressure system will require pressures to be multiplied by 1,25.

---

1) 1 bar = 0,1 MPa = 10<sup>5</sup> Pa; 1 MPa = 1 N/mm<sup>2</sup>.

# Road vehicles — Compressed natural gas (CNG) fuel system components —

## Part 2: Performance and general test methods

### 1 Scope

This part of ISO 15500 specifies performance and general test methods for compressed natural gas (CNG) fuel system components intended for use on the types of motor vehicles defined in ISO 3833.

This part of ISO 15500 is applicable to vehicles (mono-fuel, bi-fuel or dual-fuel applications) using compressed natural gas in accordance with ISO 15403 (all parts). It is not applicable to the following:

- a) liquefied natural gas (LNG) fuel system components located upstream of, and including, the vaporizer;
- b) fuel containers;
- c) stationary gas engines;
- d) container-mounting hardware;
- e) electronic fuel management;
- f) refuelling receptacles.

### 2 Normative references

The following documents, in whole or in part, are normatively referenced in this document and are indispensable for its application. For dated references, only the edition cited applies. For undated references, the latest edition of the referenced document (including any amendments) applies.

ISO 188, *Rubber, vulcanized or thermoplastic — Accelerated ageing and heat resistance tests*

ISO 1431-1, *Rubber, vulcanized or thermoplastic — Resistance to ozone cracking — Part 1: Static and dynamic strain testing*

ISO 1817, *Rubber, vulcanized or thermoplastic — Determination of the effect of liquids*

ISO 9227, *Corrosion tests in artificial atmospheres — Salt spray tests*

ISO 15500-1:2015, *Road vehicles — Compressed natural gas (CNG) fuel system components — Part 1: General requirements and definitions*

### 3 Terms and definitions

For the purposes of this document, the terms and definitions given in ISO 15500-1 apply.

### 4 General

**4.1** Unless otherwise stated, the tests shall be conducted at a room temperature of  $20\text{ °C} \pm 5\text{ °C}$ .

**4.2** Components shall comply with the tests specified in this part of ISO 15500 as well as the relevant parts of ISO 15500, as applicable for each component.

NOTE Because of the peculiarities of some components, the list of tests given in this part of ISO 15500, (Clauses 5 to 15) is not exhaustive. Where additional tests are required, their provisions are given in other parts of ISO 15500.

**4.3** Unless otherwise specified, all tests shall be conducted using dry air or nitrogen. Tests may also be conducted with natural gas provided appropriate safety measures are taken. The dew point of the test gas at the test pressure shall be at the temperature at which there is no icing, or hydrate or liquid formation.

Unless otherwise specified, all pressures shall have a maximum tolerance of  $\pm 5\%$ .

Unless otherwise specified, all temperatures shall have a maximum tolerance of  $\pm 5\%$ .

Unless otherwise specified, all dimensions shall have a maximum tolerance of  $\pm 5\%$ .

## **5 Hydrostatic strength**

A component shall not show any visible evidence of rupture when subjected to the following test procedure.

Plug the outlet opening of the component and have the valve seats or internal blocks assume the open position. Apply, with a test fluid, the hydrostatic pressure specified in the applicable part of ISO 15500 to the inlet of the component for a period of at least 3 min.

The hydrostatic pressure shall then be increased at a rate of less than or equal to 1,4 MPa/s until component failure. The hydrostatic pressure at failure shall be recorded. The failure pressure of previously tested components shall be no less than 80 % of the failure pressure of the virgin component.

The samples used in this test shall not be used for any other testing.

## **6 Leakage**

### **6.1 General**

**6.1.1** Prior to conditioning, purge the component with nitrogen, then seal it at 30 % of the working pressure using nitrogen, dry air or natural gas.

**6.1.2** Conduct all tests while the device is continuously exposed to the specified test temperatures. The device shall either be bubble-free or display a leakage rate of less than 20 Ncm<sup>3</sup>/h when subjected to the following test method.

If components are subjected to more than one working pressure, the test may be conducted in subsequent steps.

### **6.2 External leakage**

**6.2.1** Plug each device outlet into the appropriate mating connection.

**6.2.2** Apply pressurized air, nitrogen or natural gas to the inlet of the test device.

**6.2.3** At all test temperatures, immerse the components in a suitable test medium for 2 min  $\left( \begin{matrix} +30 \\ 0 \end{matrix} \right)$  s or use a helium vacuum test (global accumulation method) or other equivalent method.



**6.2.4** If there are no bubbles for the specified time period, the sample passes the test. If bubbles are detected, measure the leakage rate using an appropriate method; the leakage rate should not be more than that specified in [6.1.2](#).

### 6.3 Internal leakage

**6.3.1** The internal leakage test is applicable only to devices in the closed position. The aim of this test is to check the pressure tightness of the closed system.

**6.3.2** Connect the inlet or outlet (as applicable) of the device to the appropriate mating connection, leaving the opposite connection(s) open.

**6.3.3** Apply the test pressure to the inlet or outlet (as applicable) of the device using air, nitrogen or natural gas as the test fluid.

**6.3.4** At all applicable test temperatures mentioned in [6.4](#), immerse the component in a suitable test medium for 2 min  $\left( \begin{matrix} +30 \\ 0 \end{matrix} \right)$  s or used any other equivalent method.

**6.3.5** If there are no bubbles for the specified time period, the sample passes the test. If bubbles are detected, measure the leakage rate using an appropriate method; the leakage rate should not be more than that specified in [6.1.2](#).

### 6.4 Test conditions

**6.4.1** The device shall be conditioned at a low temperature of  $-40\text{ °C}$  ( $+0\text{ °C}$   $-5\text{ °C}$ ) or  $-20\text{ °C}$  ( $+0\text{ °C}$   $-5\text{ °C}$ ), as applicable, and pressurized at 75 % and 2,5 % of the working pressure.

**6.4.2** The device shall be conditioned at a room temperature and pressurized at 2,5 % and 150 % of the working pressure.

**6.4.3** The device shall be conditioned at a high temperature of  $85\text{ °C}$  ( $-0\text{ °C}$   $+5\text{ °C}$ ) or  $120\text{ °C}$  ( $-0\text{ °C}$   $+5\text{ °C}$ ), as applicable, and pressurized at 5 % and 150 % of the working pressure.

## 7 Excess torque resistance

A component designed to be connected directly to threaded fittings shall be capable of withstanding, without deformation, breakage or leakage, a torque effort of at least 150 % of the rated installation value, when tested in accordance with the following test procedure.

- a) Test an unused component, applying the torque adjacent to the fitting.
- b) For a component having a threaded connection or threaded connections, apply the turning effort for not less than 15 min, release it, then remove the component and examine it for deformation and breakage.
- c) Subject the component to the leakage test specified in [Clause 6](#).
- d) Subject the component to the hydrostatic strength test specified in [Clause 5](#).

## 8 Bending moment

A component shall be able to operate without cracking, breaking or leaking when tested in accordance with the following procedure.

- a) Assemble the connections of the component, ensuring that they are leak-tight, to one or several appropriate mating connection(s) representative of the design. After assembly, the length of the inlet tubing shall be greater than 300 mm (see [Figure 1](#)).
- b) The outlet connection shall be rigidly supported at a distance of 25 mm from the component outlet, except in the following cases:
  - if the component has an integral mounting means that is independent of the inlet and outlet connections, the component shall be mounted using the integral mounting means specified by the manufacturer;
  - if the component is intended to be mounted using either the integral mounting means or the component outlet, the mounting means that produces the most severe test condition shall be used.
- c) Check this assembly for leaks before subjecting it to step d).
- d) With the component in the closed position, pressurize the system to 5 kPa and apply a force in accordance with [Table 1](#), at no less than 300 mm from the inlet, maintaining it for at least 15 min. Without removing the force, check the component for leakage in accordance with the test method given in [Clause 6](#), at room temperature.

NOTE Depending on how this test is performed, it may be necessary to raise the load to compensate for buoyancy.

- e) Perform step d) of the procedure four times, rotating the component by 90° around the horizontal axis between each test. Between tests, open and close (if applicable) the component three times with the bending moment removed.
- f) At completion of the above tests, remove the component and examine it for deformation; then subject it to the leakage test specified in [Clause 6](#) and the hydrostatic strength test specified in [Clause 5](#).

**Table 1 — Bending moment minimum test force**

Outside diameter of tubing mm	Force N
6	3,4
8	9,0
≥ 12	17,0

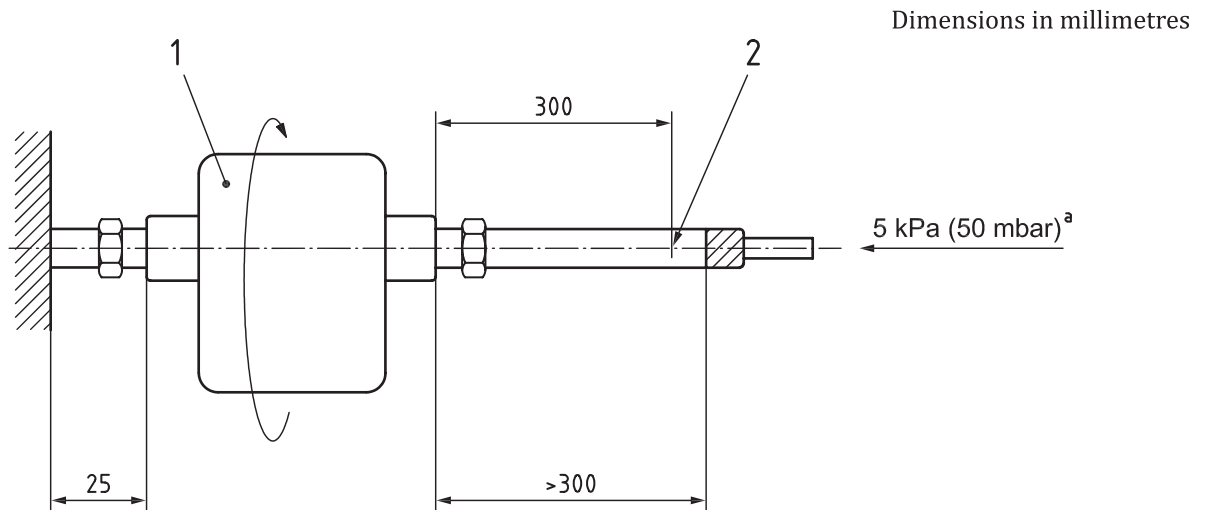
**Key**

- 1 component
- 2 force point
- a  $4 \times 90^\circ$  rotation

**Figure 1 — Bending moment****9 Continued operation****9.1 General**

For details on test methods pertaining to particular components, see the respective parts of ISO 15500. The method specified in [Clause 9](#) is general in nature and also applies to miscellaneous components.

Other components (those for which specific requirements are not specified) shall be subjected to the following continuous operation test for a total number of cycles to be determined by the testing agency. The determination of the total number of cycles shall be based on 15 000 fill cycles and/or 50 000 duty cycles.

**9.2 Test methods****9.2.1 Test procedure**

The component shall be installed as indicated and cycled using dry air, nitrogen or natural gas, under all the appropriate loads.

Connect the component securely, using a suitable fitting, to a pressurized source of dry air, nitrogen or natural gas, and subject it to the number of cycles specified in ISO 15500-3 or parts corresponding to specific component, as applicable. A cycle shall consist of one full operation and reset within an appropriate period as determined by the testing agency.

On completion of the cycling, the component shall be subjected to the hydrostatic strength test, as specified in [Clause 5](#).

During the off-cycle, the downstream pressure of the test fixture shall be lowered to a maximum of 50 % of the test pressure.

Unless otherwise specified, the test pressure shall be 100 % of the working pressure. Unless otherwise specified, the conditions of [9.2.2](#), [9.2.3](#) and [9.2.4](#) shall apply.

### 9.2.2 Room temperature cycling

Operate the component through 96 % of the total cycles at room temperature and at working pressure. On completion of the room temperature cycles, the component shall comply with the requirements of [Clause 6](#).

This test may be interrupted, if desired, at 20 % intervals for leakage testing.

### 9.2.3 High-temperature cycling

Operate the component through 2 % of the total cycles at the appropriate maximum temperature specified in ISO 15500-1:2015, 4.4, and at working pressure. On completion of the high-temperature cycles, the component shall comply with the requirements of [Clause 6](#) at the appropriate maximum temperature.

### 9.2.4 Low-temperature cycling

Operate the component through 2 % of the total cycles at the appropriate minimum temperature specified in ISO 15500-1:2015, 4.4, and at 100 % of the working pressure up to a maximum of 20 MPa. On completion of the low-temperature cycles, the component shall comply with the requirements of [Clause 6](#) at the appropriate minimum temperature.

Immediately following the continued operation tests and leakage testing, perform the hydrostatic strength test in accordance with [Clause 5](#).

## 10 Corrosion resistance

**10.1** All components shall perform safely and in compliance with [Clause 6](#) following exposure to salt spray in accordance with the following test method. AISI series 300 austenitic stainless steels, or equivalent austenitic stainless steels, are exempt from corrosion resistance testing.

**10.2** With the component supported in its normal installed position, expose it for 144 h to a salt spray (fog) test, as specified in ISO 9227. If the component is expected to operate, unprotected, in vehicle underbody service conditions, then it shall be exposed for 500 h to the salt spray (fog) test.

**10.3** Maintain the temperature within the fog chamber between 33 °C and 36 °C.

**10.4** The saline solution shall consist of 5 % sodium chloride and 95 % distilled water, by weight.

**10.5** Immediately following the corrosion resistance test, rinse the sample and gently clean it of salt deposits; then subject it to the leakage test according to [Clause 6](#).

**10.6** Immediately following the corrosion resistance test and leakage test, subject the sample to the hydrostatic strength test according to [Clause 5](#).

## 11 Oxygen ageing

No synthetic or non-metallic parts of components that provide a fuel-containing seal shall crack or show visible evidence of deterioration after oxygen ageing when tested in accordance with the following procedure.

Expose representative samples to oxygen for a minimum of 96 h at a temperature of 70 °C ± 5 °C and a pressure of at least 2 MPa (20 bar), in accordance with ISO 188.

## 12 Electrical over-voltages

All electrical components or devices containing electrical subcomponents shall withstand the application of 1,5 times its rated operating voltage  $\pm 5\%$  for periods of at least 3 min without creating an unsafe condition. Failure to open is not considered an unsafe condition.

## 13 Non-metallic material immersion

**13.1** Non-metallic material used in a component shall be subjected by the test agency to the tests described in [13.2](#) and [13.3](#), except where the applicant submits a test result declaration for tests carried out on the material provided by the manufacturer.

**13.2** A part made of non-metallic material in contact with natural gas shall not show excessive change in volume or weight when tested in accordance with the following procedure.

- a) Prepare, measure and weigh one or more representative samples of each non-metallic material used in a component, then immerse the sample or samples at room temperature in natural gas, at a pressure equal to its working pressure, but not less than 100 kPa, for a minimum of 70 h.
- b) Immediately following this period of immersion, rapidly reduce the test pressure to atmospheric pressure without causing shredding or disintegration.

No tested sample shall exhibit swelling greater than 25 % or shrinkage greater than 1 %. The weight change shall not exceed 10 %.

**13.3** Non-metallic material used in a component that is likely to be exposed to ester-based or alpha-olefin-based synthetic compressor oils, including non-synthetic compressor oils, shall not show excessive change in volume or weight when tested in accordance with ISO 1817 or the following procedure.

- a) Prepare, measure and weigh one or more representative samples of each non-metallic material used in a component, then immerse the sample or samples at room temperature in holders, each containing one of the test fluids, for a minimum of 70 h.
- b) Following this period of immersion, remove and measure the test samples, within 1 h.

No sample shall exhibit swelling greater than 25 % or shrinkage greater than 1 %. The weight change shall not exceed 10 %.

**13.4** non-metallic part in contact with CNG shall not show excessive volume change or loss of weight.

**13.4.1** Test the resistance to n-pentane according to ISO 1817 with the following conditions:

- a) medium: n-pentane;
- b) temperature: 23 °C (tolerance according to ISO 1817);
- c) immersion period: 72 h.

**13.4.2** Requirements:

Maximum change in volume 20 %;

After storage in air with a temperature of 40 °C for a period of 48 h, mass compared to the original value may not decrease more than 5 %.

## 14 Vibration resistance

Components with moving parts shall remain undamaged and shall continue to operate and meet the requirements of their leakage tests and hydrostatic strength test after the vibration test has been carried out in accordance with the following test procedure.

Vibrate the component for 30 min, pressurized to its working pressure with dry air, nitrogen or natural gas, and sealed at both ends, along each of the three orthogonal axes at the most severe resonant frequency determined as follows:

- by an acceleration of 1,5 g;
- within a sinusoidal frequency range of 10 Hz to 500 Hz;
- with a sweep time of 10 min.

If the resonance frequency is not found in this range, the test shall be conducted at 500 Hz.

On completion of the test, the component shall not show any indication of fatigue or component damage, and shall comply with the leakage test specified in [Clause 6](#) and the hydrostatic strength test specified in [Clause 5](#).

## 15 Brass material compatibility

All fuel-containing brass components or subcomponents, for which a satisfactory declaration of properties is not submitted by the applicant, shall be tested in accordance with the following procedure (component manufacturers able to provide documentation attesting to the field-worthiness of their products are exempted from this requirement).

- a) Subject each test sample to the physical stresses normally imposed on, or within, a part as a result of its assembly with other components. Apply these stresses to the sample prior to testing and maintain them throughout the test. Samples with thread, intended to be used for installing the product in the field, shall have the threads engaged and tightened to the torque specified in the instruction manual of the sample or specified by the manufacturer. Polytetrafluoroethylene (PTFE) tape or pipe compounds shall not be used on the threads.
- b) Degrease three samples and expose them continuously for 10 d at a set position to a moist ammonia-air mixture, maintained in a glass chamber of approximately 30 l in capacity, with a glass cover. Aqueous ammonia having a specific gravity of 0,94 shall be maintained at the bottom of the glass chamber, below the samples, at a concentration of 21,2 ml/l of chamber volume. Maintain approximately 600 cm<sup>3</sup> of aqueous ammonia, with a relative density (specific gravity) of 0,94, at the bottom of the glass chamber, below the samples. Position the samples 40 mm above the aqueous ammonia solution, supported by an inert tray. Maintain the moist ammonia-air mixture in the chamber at atmospheric pressure and at a temperature of 34 °C ± 2 °C.

After being subjected to the conditions of this procedure, samples shall show no evidence of cracking when examined at a magnification of 25×.

## 16 Ozone ageing for vulcanized or thermoplastic rubbers

**16.1** The test shall be in compliance with ISO 1431-1.

The test piece, which shall be stressed to 20 % elongation, shall be exposed to air at 40 °C with an ozone concentration of 50 parts per hundred million during 72 h.

**16.2** No cracking of the test piece is allowed. (After being subjected to the conditions of this procedure, samples shall show no evidence of cracking when examined at a magnification of 25×.)



## 17 Resistance to dry heat for vulcanized or thermoplastic rubbers

The test shall be done in compliance with ISO 188.

The test piece shall be exposed to air at a temperature equal to the maximum operating temperature (85 °C or 120 °C as applicable) for 168 h.

The allowable change in tensile strength shall not exceed +25 %.

The allowable change in ultimate elongation shall not exceed the following values:

- a) maximum increase 10 %;
- b) maximum decrease 30 %.

## 18 Automotive fluid exposure

### 18.1 General

External portions of components shall be able to withstand exposure to the following fluids without mechanical degradation. Resistance shall be determined by the test in [18.2](#) except when the manufacturer can demonstrate by other means that the material is resistant to these fluids.

### 18.2 Test Method

The external surfaces of the component shall be exposed to the following test. The inlet and outlet connections of the component shall be connected or capped in accordance with the component manufacturers installation instructions. The test shall be performed at ambient temperature. The component shall be exposed by spraying the exterior of the component 24 times at one hour intervals. The test shall either be performed over 24 straight hours or during a maximum of three consecutive days (e.g. 8 times a day over three days).

Alternatively, the component may be immersed in the solution for a period of 24 h. In the immersion method, the fluid shall be replenished as needed to ensure complete immersion for the duration of the test.

An individual test shall be performed with each of the three fluids specified in [18.3](#). One component may be used for all three exposures sequentially.

### 18.3 Fluids

The following fluids shall be used for testing:

- a) sulfuric acid: 19 % solution by volume in water;
- b) ethanol/gasoline: 5/95 % concentration of E5 fuel meeting the requirements of ASTM D4814;
- c) windshield washer fluid: 50 % by volume solution of methanol and water.

### 18.4 Pass criteria

After exposure to each chemical, the component shall be wiped off and rinsed with water and examined.

The component shall not show signs of mechanical degradation that could impair the function of the component such as cracking, softening, or swelling. Cosmetic changes such as pitting or staining are not considered failures. At the conclusion of all exposures, the component(s) shall meet the leakage requirements of [Clause 6](#) and hydrostatic strength requirements of [Clause 5](#).

## Bibliography

- [1] ISO 3833, *Road vehicles — Types — Terms and definitions*
- [2] ISO 15403-1, *Natural gas — Natural gas for use as a compressed fuel for vehicles — Part 1: Designation of the quality*
- [3] ISO/TR 15403-2, *Natural gas - Natural gas for use as a compressed fuel for vehicles — Part 2: Specification of the quality*
- [4] ISO 15500 (all parts), *Road vehicles — Compressed natural gas (CNG) fuel system components*





