

# INTERNATIONAL STANDARD

# ISO 15494

First edition  
2003-04-15

Corrected version  
2004-02-01

---

---

## Plastics piping systems for industrial applications — Polybutene (PB), polyethylene (PE) and polypropylene (PP) — Specifications for components and the system — Metric series

*Systèmes de canalisations en matières plastiques pour les applications  
industrielles — Polybutène (PB), polyéthylène (PE) et polypropylène  
(PP) — Spécifications pour les composants et le système — Série  
métrique*



Reference number  
ISO 15494:2003(E)

© ISO 2003

**PDF disclaimer**

This PDF file may contain embedded typefaces. In accordance with Adobe's licensing policy, this file may be printed or viewed but shall not be edited unless the typefaces which are embedded are licensed to and installed on the computer performing the editing. In downloading this file, parties accept therein the responsibility of not infringing Adobe's licensing policy. The ISO Central Secretariat accepts no liability in this area.

Adobe is a trademark of Adobe Systems Incorporated.

Details of the software products used to create this PDF file can be found in the General Info relative to the file; the PDF-creation parameters were optimized for printing. Every care has been taken to ensure that the file is suitable for use by ISO member bodies. In the unlikely event that a problem relating to it is found, please inform the Central Secretariat at the address given below.

© ISO 2003

All rights reserved. Unless otherwise specified, no part of this publication may be reproduced or utilized in any form or by any means, electronic or mechanical, including photocopying and microfilm, without permission in writing from either ISO at the address below or ISO's member body in the country of the requester.

ISO copyright office  
Case postale 56 • CH-1211 Geneva 20  
Tel. + 41 22 749 01 11  
Fax + 41 22 749 09 47  
E-mail [copyright@iso.org](mailto:copyright@iso.org)  
Web [www.iso.org](http://www.iso.org)

Published in Switzerland

# Contents

Page

Foreword .....	iv
Introduction.....	v
1 Scope.....	1
2 Normative references.....	2
3 Terms and definitions .....	4
4 Symbols and abbreviated terms.....	7
5 Material.....	8
6 General characteristics.....	10
7 Geometrical characteristics .....	11
8 Mechanical characteristics.....	12
9 Physical characteristics .....	12
10 Chemical characteristics .....	12
11 Electrical characteristics .....	13
12 Performance requirements.....	13
13 Classification of components .....	14
14 Design of a thermoplastics piping system for industrial applications.....	14
15 Installation of piping systems.....	15
16 Declaration of compliance.....	15
17 Marking.....	15
<b>Annex A (normative) Specific characteristics and requirements for industrial piping systems made from polybutene (PB).....</b>	<b>18</b>
<b>Annex B (normative) Specific characteristics and requirements for industrial piping systems made from polyethylene (PE) .....</b>	<b>32</b>
<b>Annex C (normative) Specific characteristics and requirements for industrial piping systems made from polypropylene (PP).....</b>	<b>59</b>
<b>Bibliography.....</b>	<b>88</b>

## Foreword

ISO (the International Organization for Standardization) is a worldwide federation of national standards bodies (ISO member bodies). The work of preparing International Standards is normally carried out through ISO technical committees. Each member body interested in a subject for which a technical committee has been established has the right to be represented on that committee. International organizations, governmental and non-governmental, in liaison with ISO, also take part in the work. ISO collaborates closely with the International Electrotechnical Commission (IEC) on all matters of electrotechnical standardization.

International Standards are drafted in accordance with the rules given in the ISO/IEC Directives, Part 3.

The main task of technical committees is to prepare International Standards. Draft International Standards adopted by the technical committees are circulated to the member bodies for voting. Publication as an International Standard requires approval by at least 75 % of the member bodies casting a vote.

Attention is drawn to the possibility that some of the elements of this International Standard may be the subject of patent rights. ISO shall not be held responsible for identifying any or all such patent rights.

ISO 15494 was prepared by Technical Committee ISO/TC 138, *Plastics pipes, fittings and valves for the transport of fluids*, Subcommittee SC 3, *Plastics pipes and fittings for industrial applications*.

This document has been prepared under a mandate given by the European Commission and the European Free Trade Association and supports essential requirements of EU Directives.

At the date of publication of this International Standard, the following standards had been published for piping systems, used for industrial applications, made from other types of plastic:

ISO 10931 (all parts), *Plastics piping systems for industrial applications — Poly(vinylidene fluoride) (PVDF)*

ISO 15493, *Plastics piping systems for industrial applications — Acrylonitrile-butadiene-styrene (ABS), unplasticized poly(vinyl chloride) (PVC-U) and chlorinated poly(vinyl chloride) (PVC-C) — Specifications for components and the system — Metric series*.

Annexes A, B and C form a normative part of this International Standard.

This corrected version of ISO 15494:2003 incorporates the following corrections:

- in Table A.1, footnote “c”, the reference to Table D.4 has been deleted;
- in Table C.2, footnote “c”, the reference to Table D.22 has been deleted.

## Introduction

This International Standard specifies the characteristics and requirements for a piping system and its components made from polybutene (PB), polyethylene (PE) or polypropylene (PP), as applicable, intended to be used for industrial applications above ground by authorities, design engineers, certification bodies, inspection bodies, test laboratories, manufacturers and users.

© ISO 2003. All rights reserved.



# Plastics piping systems for industrial applications — Polybutene (PB), polyethylene (PE) and polypropylene (PP) — Specifications for components and the system — Metric series

## 1 Scope

This International Standard specifies the characteristics and requirements for components such as pipes, fittings and valves made from one of the following materials:

- polybutene (PB);
- polyethylene (PE);
- polypropylene (PP);

intended to be used for thermoplastics piping systems in above-ground industrial applications.

This International Standard is applicable to PB, PE or PP pipes, fittings, valves and ancillary equipment, to their joints and to joints with components made of other plastics and non-plastics materials, depending on their suitability, intended to be used for the conveyance of liquid and gaseous fluids as well as of solid matter in fluids for industrial applications such as:

- chemical plants;
- industrial sewerage engineering;
- power engineering (cooling and general-purpose water supply);
- electroplating and pickling plants;
- the semiconductor industry;
- agricultural production plants;
- water treatment.

NOTE 1 Where relevant, national regulations for specific applications (e.g. water treatment) apply.

Other application areas are permitted if the requirements of this International Standard and/or applicable national requirements are fulfilled.

Relevant regulations in respect of fire behaviour and explosion risk are applicable if applications are envisaged for inflammable media.

The components have to withstand the mechanical, thermal and chemical demands to be expected and have to be resistant to the fluids to be conveyed.

Characteristics and requirements which are applicable to all three materials (PB, PE and PP) are covered by the relevant clauses of this International Standard. Those characteristics and requirements which are dependent on the material are given for each material in the relevant annex (see Table 1).

**Table 1 — Material-specific annexes**

Material	Annex
Polybutene (PB)	A
Polyethylene (PE)	B
Polypropylene (PP)	C

NOTE 2 Components conforming to any of the product standards listed in the bibliography or to national standards, as applicable, may be used with components conforming to this International Standard provided they conform to the requirements for joint dimensions and to the other relevant requirements of this standard.

## 2 Normative references

The following normative documents contain provisions which, through reference in this text, constitute provisions of this International Standard. For dated references, subsequent amendments to, or revisions of, any of these publications do not apply. However, parties to agreements based on this International Standard are encouraged to investigate the possibility of applying the most recent editions of the normative documents indicated below. For undated references, the latest edition of the normative document referred to applies. Members of ISO and IEC maintain registers of currently valid International Standards.

ISO 7-1, *Pipe threads where pressure-tight joints are made on the threads — Part 1: Dimensions, tolerances and designation*

ISO 179-2:1997, *Plastics — Determination of Charpy impact properties — Part 2: Instrumented impact test*

ISO 228-1, *Pipe threads where pressure-tight joints are not made on the threads — Part 1: Dimensions, tolerances and designation*

ISO 265-1, *Pipes and fittings of plastics materials — Fittings for domestic and industrial waste pipes — Basic dimensions: Metric series — Part 1: Unplasticized poly(vinyl chloride) (PVC-U)*

ISO 472, *Plastics — Vocabulary*

ISO 727-1, *Fittings made from unplasticized poly(vinyl chloride) (PVC-U), chlorinated poly(vinyl chloride) (PVC-C) or acrylonitrile/butadiene/styrene (ABS) with plain sockets for pipes under pressure — Part 1: Metric series*

ISO 1043-1, *Plastics — Symbols and abbreviated terms — Part 1: Basic polymers and their special characteristics*

ISO 1133, *Plastics — Determination of the melt mass-flow rate (MFR) and the melt volume-flow rate (MVR) of thermoplastics*

ISO 1167:1996, *Thermoplastics pipes for the conveyance of fluids — Resistance to internal pressure — Test method*

ISO 1183-2, *Plastics — Methods for determining the density of non-cellular plastics — Part 2: Density gradient column method*

ISO 2505-1:1994, *Thermoplastics pipes — Longitudinal reversion — Part 1: Determination methods*

ISO 2505-2:1994, *Thermoplastics pipes — Longitudinal reversion — Part 2: Determination parameters*

ISO 3126, *Plastics piping systems — Plastics piping components — Measurement and determination of dimensions*



- ISO 3213, *Polypropylene (PP) pipes — Effect of time and temperature on expected strength*
- ISO 4065, *Thermoplastics pipes — Universal wall thickness table*
- ISO 6964, *Polyolefin pipes and fittings — Determination of carbon black content by calcination and pyrolysis — Test method and basic specification*
- ISO 9080, *Plastics piping and ducting systems — Determination of the long-term hydrostatic strength of thermoplastics materials in pipe form by extrapolation*
- ISO/TR 10358, *Plastics pipes and fittings — Combined chemical-resistance classification table*
- ISO/TR 10837, *Determination of the thermal stability of polyethylene (PE) for use in gas pipes and fittings*
- ISO 11922-1:1997, *Thermoplastics pipes for the conveyance of fluids — Dimensions and tolerances — Part 1: Metric series*
- ISO 12092, *Fittings, valves and other piping system components made of unplasticized poly(vinyl chloride) (PVC-U), chlorinated poly(vinyl chloride) (PVC-C), acrylonitrile-butadiene-styrene (ABS) and acrylonitrile-styrene-acrylester (ASA) for pipes under pressure — Resistance to internal pressure — Test method*
- ISO 12162, *Thermoplastics materials for pipes and fittings for pressure applications — Classification and designation — Overall service (design) coefficient*
- ISO 12230, *Polybutene (PB) pipes — Effect of time and temperature on the expected strength*
- ISO 13477, *Thermoplastics pipes for the conveyance of fluids — Determination of resistance to rapid crack propagation (RCP) — Small-scale steady-state test (S4 test)*
- ISO 13478, *Thermoplastics pipes for the conveyance of fluids — Determination of resistance to rapid crack propagation (RCP) — Full-scale test (FST)*
- ISO 13949, *Method for the assessment of the degree of pigment dispersion in polyolefin pipes, fittings and compounds*
- ISO 15853, *Thermoplastics materials — Preparation of tubular test pieces for the determination of the hydrostatic strength of materials used for injection moulding*
- ISO 16135:—<sup>1)</sup>, *Industrial valves — Ball valves of thermoplastics materials*
- ISO 16136:—<sup>1)</sup>, *Industrial valves — Butterfly valves of thermoplastics materials*
- ISO 16137:—<sup>1)</sup>, *Industrial valves — Check valves of thermoplastics materials*
- ISO 16138:—<sup>1)</sup>, *Industrial valves — Diaphragm valves of thermoplastics materials*
- ISO 16139:—<sup>1)</sup>, *Industrial valves — Gate valves of thermoplastics materials*
- ISO 21787:—<sup>1)</sup>, *Industrial valves — Globe valves of thermoplastics materials*
- IEC 60364-1, *Electrical installations of buildings — Part 1: Fundamental principles, assessment of general characteristics, definitions*
- IEC 60449, *Voltage bands for electrical installations of buildings*
- IEC 60529, *Degrees of protection provided by enclosures (IP code) (Consolidated edition including Amendment 1)*

---

1) To be published.

### 3 Terms and definitions

For the purposes of this International Standard, the terms and definitions given in ISO 472 and ISO 1043-1, plus the following apply.

#### 3.1 Geometrical definitions

NOTE The symbols  $d_e$  and  $e$  correspond to  $d_{ey}$  and  $e_y$  given in other International Standards such as ISO 11922-1.

##### 3.1.1 nominal outside diameter

$d_n$   
specified outside diameter of a component, which is identical to the minimum mean outside diameter,  $d_{em,min}$ , in millimetres

NOTE The nominal inside diameter of a socket is equal to the nominal outside diameter of the corresponding pipe.

##### 3.1.2 outside diameter at any point

$d_e$   
outside diameter measured through the cross-section at any point on a pipe, or the spigot end of a fitting, rounded up to the nearest 0,1 mm

##### 3.1.3 mean outside diameter

$d_{em}$   
measured length of the outer circumference of a pipe, or the spigot end of a fitting, divided by  $\pi$  ( $\approx 3,142$ ), rounded up to the nearest 0,1 mm

##### 3.1.4 mean inside diameter of a socket

$d_{im}$   
arithmetic mean of two measured inside diameters perpendicular to each other

##### 3.1.5 nominal size of flange DN

numerical designation for the size of a flange for reference purposes, related to the manufactured dimension in millimetres

##### 3.1.6 out-of-roundness

difference between the measured maximum outside diameter and the measured minimum outside diameter in the same cross-sectional plane of a pipe, or the spigot end of a fitting, or the difference between the measured maximum inside diameter and the measured minimum inside diameter in the same cross-sectional plane of a socket

##### 3.1.7 nominal wall thickness

$e_n$   
wall thickness, in millimetres, corresponding to the minimum wall thickness,  $e_{min}$

##### 3.1.8 wall thickness at any point

$e$   
measured wall thickness at any point around the circumference of a component, rounded up to the nearest 0,1 mm

### 3.1.9 pipe series S

dimensionless number related to the nominal outside diameter,  $d_n$ , and the nominal wall thickness,  $e_n$

NOTE 1 The pipe series S is related to the pipe geometry as shown in equation (1):

$$S = \frac{d_n - e_n}{2e_n} \quad (1)$$

NOTE 2 Flanges are designated on the basis of PN.

### 3.1.10 standard dimension ratio SDR

ratio of the nominal outside diameter,  $d_n$ , of a pipe to its nominal wall thickness,  $e_n$

NOTE In accordance with ISO 4065, the standard dimension ratio SDR and the pipe series S are related as shown in equation (2):

$$SDR = 2S + 1 \quad (2)$$

## 3.2 Definitions of materials

### 3.2.1 virgin material

material in a form such as granules or powder that has not been previously processed other than for compounding and to which no reprocessable or recyclable materials have been added

### 3.2.2 reprocessable material

material prepared from clean unused rejected pipes, fittings or valves, produced in a manufacturer's plant by a process such as moulding or extrusion, which will be reprocessed in the same plant and for which the complete formulation or material specification is known

NOTE 1 Such material may include trimmings from the production of such pipes, fittings and valves.

NOTE 2 In the case of valves, only those thermoplastics parts which are made from material conforming to this International Standard may be considered as reprocessable material.

## 3.3 Definitions related to material characteristics

### 3.3.1 lower confidence limit

$\sigma_{LCL}$   
quantity with the dimensions of stress, expressed in megapascals, which can be considered as a property of the material and represents the 97,5 % lower confidence limit of the predicted long-term hydrostatic strength at a given temperature,  $T$ , and time,  $t$ , determined by pressurizing internally with water

### 3.3.2 minimum required strength MRS

value of  $\sigma_{LCL}$  at 20 °C and 50 years, rounded down to the next lower value in the R 10 series when  $\sigma_{LCL}$  is less than 10 MPa, or to the next lower value in the R 20 series when  $\sigma_{LCL}$  is greater than or equal to 10 MPa

NOTE The R 10 and R 20 series are the Renard number series as defined in ISO 3 and ISO 497.

**3.3.3**  
**design stress**

$\sigma_s$   
allowable stress, in megapascals, for a given application or set of service conditions

NOTE It is derived by dividing the MRS by the coefficient  $C$ , as in equation (3), then rounding to the next lower value in the R 10 or R 20 series, as applicable:

$$\sigma_s = \frac{MRS}{C} \quad (3)$$

**3.3.4**  
**overall service (design) coefficient**

$C$   
overall coefficient, with a value greater than one, which takes into consideration service conditions as well as the properties of the components of a piping system other than those represented in the lower confidence limit,  $\sigma_{LCL}$

**3.3.5**  
**melt mass-flow rate**  
**MFR**

value relating to the viscosity of a molten plastics material at a specified temperature and rate of shear, expressed in grams per ten minutes (g/10 min)

**3.4 Definitions related to service conditions**

**3.4.1**  
**nominal pressure**

**PN**  
numerical designation used for reference purposes and related to the mechanical characteristics of the components of a piping system

NOTE 1 A pressure, in bars, numerically equal to PN is identical to the maximum allowable pressure, PS, as defined by EU Directive 97/23/ECC (PED), if both pressures are taken at 20 °C.

NOTE 2 For plastics piping systems conveying water, PN corresponds to the maximum continuous operating pressure in bars which can be sustained for water at 20 °C for 50 years, based on the minimum overall service (design) coefficient and calculated using the following equation:

$$PN = \frac{10\sigma_s}{S} = \frac{20\sigma_s}{SDR - 1} \quad (4)$$

where

- $\sigma_s$  is expressed in N/mm<sup>2</sup>;
- PN is expressed in bars <sup>2)</sup>.

---

2) 1 bar = 0,1 MPa = 10<sup>5</sup> N/mm<sup>2</sup>.

### 3.4.2 hydrostatic stress

$\sigma$   
stress induced in the wall of a pipe when an internal hydrostatic pressure is applied

NOTE 1 The hydrostatic stress, in megapascals, is related to the applied internal hydrostatic pressure,  $p$ , the wall thickness,  $e$ , at any point and the mean outside diameter,  $d_{em}$ , of a pipe and calculated using the following equation:

$$\sigma = p \times \frac{d_{em} - e}{2e} \quad (5)$$

NOTE 2 Equation (5) is applicable to pipes only.

### 3.4.3 long-term hydrostatic stress

constant hydrostatic stress that is maintained in a component for a sustained period of time

## 4 Symbols and abbreviated terms

### 4.1 Symbols

$C$	overall service (design) coefficient (design factor)
$d_e$	outside diameter (at any point)
$d_{em}$	mean outside diameter
$d_{im}$	mean inside diameter of socket
$d_n$	nominal outside diameter
DN	nominal size of flange
$e$	wall thickness (at any point)
$e_n$	nominal wall thickness
$l_0$	free length
$p$	internal hydrostatic pressure
$T$	temperature
$t$	time
$\rho$	density of material
$\sigma$	hydrostatic stress
$\sigma_{LCL}$	lower confidence limit
$\sigma_s$	design stress

## 4.2 Abbreviations

MFR	melt mass-flow rate
MOP	maximum operating pressure
MRS	minimum required strength
OIT	oxidation induction time
PB	polybutene
PE	polyethylene
PP	polypropylene
PP-H	polypropylene homopolymer
PP-B	polypropylene block-copolymer
PP-R	polypropylene random-copolymer
PN	nominal pressure
PS	maximum allowable pressure
PT	test pressure (corresponds to the symbol $p$ usually used)
S	pipe series
SDR	standard dimension ratio
TIR	true impact rate

## 5 Material

### 5.1 General

The material from which the components are made shall be PB, PE or PP, as applicable, to which are added those additives that are needed to facilitate the manufacture of pipes and fittings conforming to this International Standard.

If additives are used, they shall be uniformly dispersed.

Additives shall not be used, separately or together, in quantities sufficient to impair the fabrication or fusion-jointing characteristics of the components or to impair the chemical, physical or mechanical characteristics as specified in this International Standard.

### 5.2 Hydrostatic strength properties

The material shall be evaluated in accordance with ISO 9080 where a pressure test is carried out in accordance with ISO 1167 to find the MRS-value in accordance with ISO 12162. The test shall be carried out using test pieces of pipe series  $S \leq 16$ .

Conformity of the relevant material to the reference curves given for PB (see Annex A), PE (see Annex B) and PP (see Annex C) shall be demonstrated in accordance with the applicable annex to this International Standard. At least 97,5 % of the data points shall be on or above the reference curves.

The material shall be as classified by the raw-material producer.

Where fittings and valves are manufactured from the same material as pipes, the material classification shall be the same as for pipes.

For the classification of a material intended only for the manufacture of fittings and valves, an injection-moulded or extruded test piece in the form of a pipe shall be used (see Figure 1) and the test pressure applied in accordance with ISO 1167. The free length  $l_0$  shall be  $3d_n$ , as defined in ISO 15853.

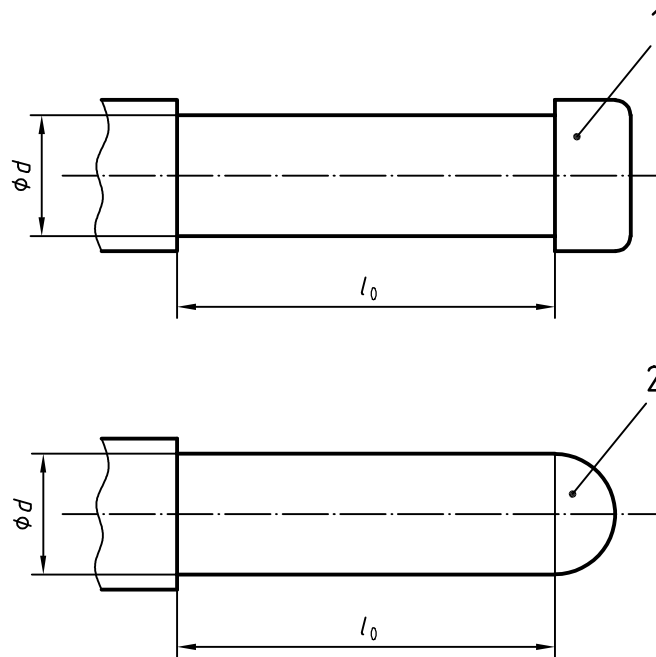

#### Key

- 1 End cap
- 2 Injection-moulded end

Figure 1 — Free length,  $l_0$ , of test piece

### 5.3 Other characteristics of material

Details of requirements on other characteristics of PB, PE and PP material are given in the applicable annex to this International Standard.

### 5.4 Reprocessable and recyclable material

The use of reprocessable material obtained during the production and testing of components in accordance with this International Standard is permitted in addition to virgin material, provided that the requirements of this International Standard are fulfilled.

Reprocessable material obtained from external sources and recyclable material shall not be used.

## 5.5 Parts not made from PB, PE or PP

### 5.5.1 General

All components shall conform to the relevant International Standards. Alternative standards may be used in cases where suitable International Standards do not exist. In all cases, the fitness for purpose of the components shall be demonstrated.

Materials and constituent elements used in making a particular component (including rubber, greases and any metal parts that may be used) shall have resistance to the external and internal environments which is comparable to that of all other elements of the piping system.

Materials other than PB, PE or PP in contact with components conforming to this International Standard shall not adversely effect the performance of the components or initiate stress cracking.

### 5.5.2 Metallic materials

All metal parts susceptible to corrosion shall be adequately protected.

When dissimilar metallic materials are used which can be in contact with moisture, steps shall be taken to avoid galvanic corrosion.

### 5.5.3 Sealing materials

Sealing materials shall have no detrimental effects on the properties of the components, joints and assemblies.

### 5.5.4 Other materials

Greases or lubricants shall not exude onto fusion-jointing areas and shall not affect the long-term performance of materials conforming to this International Standard.

## 6 General characteristics

### 6.1 Appearance

When viewed without magnification, the internal and external surfaces of the components shall be smooth, clean and free from any scoring, cavities and other surface defects that would prevent conformity to this International Standard. The components shall not contain visible impurities.

Each end of a component shall be square to its axis and shall be deburred.

### 6.2 Colour

The colour of the components will depend on the material used and shall be as given for PB, PE or PP in the applicable annex to this International Standard.

NOTE Attention is drawn to the need to take account of any relevant legislation relating to the colour coding of piping in respect of its purpose or contents for the location in which the components are intended to be used.

Components for external above-ground installations shall be adequately protected against UV radiation.



## 7 Geometrical characteristics

### 7.1 General

Dimensions shall be measured in accordance with ISO 3126 at  $(23 \pm 2)$  °C after the component has been conditioned for at least 4 h. The measurements shall not be made less than 24 h after manufacture.

The illustrations given in this International Standard are schematic sketches only, to indicate the relevant dimensions. They do not necessarily represent manufactured components. The dimensions given shall be followed. Dimensions not given shall be as specified by the manufacturer.

### 7.2 Diameters and associated tolerances

For components made from PB, PE or PP, as applicable, the diameters and associated tolerances shall conform to the applicable annex to this International Standard.

The out-of-roundness shall be measured at the point of manufacture.

### 7.3 Wall thicknesses and associated tolerances

For components made from PB, PE or PP, as applicable, the wall thicknesses and associated tolerances shall conform to the applicable annex to this International Standard.

### 7.4 Angles

The permitted deviation from the nominal or declared angle of a non-linear fitting (i.e. the change in direction of the axis of the flow through the fitting) is  $\pm 2^\circ$ .

NOTE The preferred nominal angle for a non-linear fitting is  $45^\circ$  or  $90^\circ$ .

### 7.5 Laying lengths

The laying lengths for fittings and valves shall be as declared by the manufacturer.

NOTE The laying lengths are intended to assist in the design of moulds and are not intended to be used for quality control purposes. ISO 265-1 may be used as a guide.

### 7.6 Threads

Threads used for jointing shall conform to ISO 7-1. Where a thread is used as a fastening thread for jointing an assembly (e.g. union nuts), a thread conforming to ISO 228-1 is preferred.

### 7.7 Mechanical fittings

Mechanical fittings such as adaptors, unions, compression fittings and reducing bushes may be used provided that their joint dimensions are in accordance with the applicable dimensions of components conforming to this International Standard.

### 7.8 Joint dimensions of valves

The joint dimensions of valves shall conform to the relevant dimensions of pipes and fittings conforming to this International Standard.

## 8 Mechanical characteristics

### 8.1 Resistance to internal pressure of components

Components shall withstand the hydrostatic stress induced by internal hydrostatic pressure without bursting or leakage when tested in accordance with ISO 1167 (for fittings, together with ISO 12092) under the test conditions specified for PB, PE or PP in the applicable annex to this International Standard.

### 8.2 Calculation of the test pressure for components

#### 8.2.1 Pipes

The hydrostatic test pressure,  $PT$ , in bars, shall be determined for pipes using the following equation:

$$\sigma = PT \times \frac{d_{em} - e_{min}}{2e_{min}} \quad (6)$$

where  $\sigma$  is the hydrostatic stress for PB, PE or PP as given in the applicable annex to this International Standard.

#### 8.2.2 Fittings

The hydrostatic test pressure,  $PT$ , in bars, shall be determined for fittings using equation (7). For S and SDR, the respective values for the corresponding pipe shall be taken.

$$PT = \frac{10\sigma}{S} = \frac{20\sigma}{SDR - 1} \quad (7)$$

#### 8.2.3 Valves

The hydrostatic test pressure,  $PT$ , in bars, is defined for valves in ISO 16135, ISO 16136, ISO 16137, ISO 16138, ISO 16139 or ISO 21787, as applicable, depending on the valve type.

## 9 Physical characteristics

The physical characteristics of components made from PB, PE or PP shall conform to the applicable annex to this International Standard.

## 10 Chemical characteristics

### 10.1 Effects on the component material(s)

Where fluids other than water are to be conveyed, the effect of the fluid on the component material(s) may be established by consulting the component manufacturer or by reference to ISO/TR 10358.

### 10.2 Effects on the fluids

Where fluids other than water are to be conveyed, the effect on the fluids may be established by consulting the component manufacturer.

## 11 Electrical characteristics

The electrical protection which has to be provided during the fusion-jointing process will depend on the characteristics of the electrical power supply.

NOTE The component relevant to the fusion-jointing process is part of an electrical system defined in IEC 60364-1 and in IEC 60449.

Protection against direct contact with live parts (live conductors) is required in accordance with IEC 60529. This protection is a function of the work site conditions.

The surface finish of the terminal pins shall ensure minimum electrical resistance.

## 12 Performance requirements

### 12.1 General

When components made from the same material, conforming to this International Standard, are jointed to each other, all pipes, fittings and valves, as well as the joints between them, shall conform to the requirements of the applicable annex to this International Standard.

NOTE If test pressures defined for pipes are used for assemblies made from components of dissimilar materials (e.g. threaded joints or flanged joints), the resulting strain exceeds the strain occurring under service conditions. These strains inevitably cause leakage. Therefore, in this International Standard, the time-related strain behaviour of the assemblies is taken into account and test pressures derived from the isochronous stress-strain diagram are used.

### 12.2 Preparation of test assemblies

#### 12.2.1 General

The joints shall be tested using pipes and fittings conforming to this International Standard.

The preparation of test assemblies shall take into account tolerances related to component manufacture, field assembly and the equipment used, ambient-temperature variations during installation and, where appropriate, sealing material and associated tolerances.

Test assemblies for pressure tests shall be closed with pressure-tight end-load-bearing end caps, plugs or flanges which shall be provided with connections for the entry of water and release of air.

#### 12.2.2 Heated-tool jointing

##### 12.2.2.1 Butt fusion jointing

Pipes and spigot-ended fittings designed for jointing by butt fusion shall be prepared and assembled in accordance with the manufacturer's instructions.

##### 12.2.2.2 Socket fusion jointing

Pipes and fittings designed for jointing by socket fusion shall be prepared and assembled in accordance with the manufacturer's instructions.

##### 12.2.2.3 Saddle fusion jointing

Pipes and fittings designed for jointing by saddle fusion shall be prepared and assembled in accordance with the manufacturer's instructions.

### 12.2.3 Electrofusion jointing

Pipes and fittings such as couplers or saddles designed for jointing by electrofusion shall be prepared and assembled in accordance with the manufacturer's instructions.

In addition, socket fusion fittings shall be assembled at the maximum radial clearance identified for testing purposes. For couplings of nominal outside diameter  $d_n \geq 225$  mm, the adjoining pipes shall be arranged to provide an angular deflection of  $1,5^\circ$ .

### 12.2.4 Saddle fittings

Saddle fittings (for electrofusion and heated-tool fusion) which are designed for jointing to a pressurized pipe shall be fusion-jointed to a test pipe while the pipe is pneumatically or hydraulically pressurized to the maximum permitted operating pressure specified in the manufacturer's instructions.

**WARNING — Precautions to minimize the risk of injury should be taken, particularly when the test piece is pressurized pneumatically. In addition, relevant safety regulations should be taken into account.**

Threaded caps on saddle fittings shall be assembled for testing without any mechanical support.

### 12.2.5 Mechanical jointing

Pipes and fittings designed for mechanical jointing shall be prepared and assembled in accordance with the manufacturer's instructions.

## 12.3 Fusion-jointing compatibility of components and materials

The component manufacturer shall declare which components and materials conforming to this International Standard may be fusion-jointed using the same procedure (e.g. fusion-jointing times, temperatures and pressures) to give a joint which conforms to the requirements of this International Standard. If there is a need for deviations from the fusion-jointing procedure, the manufacturer shall state this.

## 13 Classification of components

The classification of pipes shall be based on the pipe series S or the standard dimension ratio SDR or the nominal pressure PN, as applicable.

The classification of fittings shall be based on that of the corresponding pipe together with the pipe series S or the standard dimension ratio SDR or the nominal pressure PN, as applicable.

Valves shall be classified in accordance with the requirements of ISO 16135, ISO 16136, ISO 16137, ISO 16138, ISO 16139 or ISO 21787, as applicable, depending on the valve type.

## 14 Design of a thermoplastics piping system for industrial applications

NOTE Due to the fact that there are several calculation methods available for the design of thermoplastics piping systems for industrial applications, only general guidance can be given.

For the design of a piping system (e.g. determination of the maximum allowable pressure,  $p_s$ ), the following parameters should be taken into account:

- the temperature,  $T$ , usually constant (if not, then Miner's rule should be used);
- the pressure,  $p$ , usually constant (if not, then Miner's rule should be used);
- the lifetime,  $t$  (usually 25 years);

- the stress,  $\sigma$ , calculated using the equations given in the first clause of Annex A, B or C, as applicable;
- the chemical resistance of the material to the fluid;
- the required design factor,  $C$ ;
- the influence of wear and abrasion by any solid matter in the fluid;
- the influence of changes in length (caused by temperature, swelling, internal pressure);
- the kind of installation (fixed, floating, etc.);
- the distances between supports in the installed piping system.

With these parameters, together with the minimum required hydrostatic strength curves, a piping system can be designed taking into account any national and/or local requirements and, where appropriate, backed up by experimental design methods.

## 15 Installation of piping systems

For the installation of components conforming to this International Standard, national and/or local requirements and relevant codes of practice shall apply.

In addition, the pipe manufacturer may provide a recommended practice for installation covering transport, storage and handling of the components, as well as their installation in accordance with applicable national and/or local requirements.

For external above-ground installation, additional requirements depending on the climate shall be agreed on between manufacturer and purchaser.

## 16 Declaration of compliance

The manufacturer shall declare compliance with this International Standard by marking components in accordance with clause 17.

## 17 Marking

### 17.1 General

Marking elements shall be printed or formed directly on the component, or printed on a label or the packaging, in such a way that legibility is not affected by storage, weathering, handling or installation.

**NOTE** The manufacturer is not responsible for the marking on a component becoming illegible due to actions caused during installation and use such as painting, scratching or covering over, or the use of detergents, etc., unless agreed with or specified by the manufacturer.

Marking shall not initiate cracks or other types of defect which adversely influence the performance of the component.

If printing is used, the colour of the printed information shall differ from the basic colour of the component.

The size of the marking shall be such that the marking is legible without magnification.

### 17.2 Minimum required marking of pipes

The minimum required marking of pipes is given in Table 2.

Pipes shall be marked at intervals of maximum 1 m, at least once per pipe.

**Table 2 — Minimum required marking of pipes**

Information	Marking or symbol
Number of this International Standard	ISO 15494
Manufacturer's name and/or trade mark	Name or symbol
Nominal outside diameter, $d_n$	e.g. 110
Nominal wall thickness, $e_n$ or pipe series S or standard dimension ratio SDR or nominal pressure PN	e.g. 10,0 e.g. S 5 or SDR 11 e.g. PN 10
Material <sup>a</sup>	e.g. PP
Manufacturer's information	b
<sup>a</sup> If more than one type of material could be involved, the exact type shall be indicated. <sup>b</sup> To provide traceability, the following details shall be given: — the production period (year and month), in figures or in code form; — a name or code for the production site if the manufacturer is producing at different sites.	

### 17.3 Minimum required marking of fittings

The minimum required marking of fittings is given in Table 3.

Table 3 — Minimum required marking of fittings

Information	Marking or symbol
Number of this International Standard <sup>a</sup>	ISO 15494
Manufacturer's name and/or trade mark	Name or symbol
Nominal outside diameter(s), $d_n$	e.g. 63-32-63
Nominal wall thickness, $e_n$ or pipe series S or standard dimension ratio SDR or nominal pressure PN	5,8 e.g. S 5 or SDR 11 e.g. PN 10
Nominal size DN <sup>b</sup>	e.g. DN 50
Material <sup>c</sup>	e.g. PP
Manufacturer's information	d
<p><sup>a</sup> This information shall be marked at least on the packaging.</p> <p><sup>b</sup> Applicable to flanges only.</p> <p><sup>c</sup> If more than one type of material could be involved, the exact type shall be indicated at least on the packaging.</p> <p><sup>d</sup> For fittings with <math>d_n &gt; 32</math> mm, the following details shall be given to provide traceability:</p> <ul style="list-style-type: none"> <li>— the production period (year and month), in figures or in code form;</li> <li>— a name or code for the production site if the manufacturer is producing at different sites.</li> </ul>	

#### 17.4 Minimum required marking of valves

Valves shall be marked in accordance with the requirements of ISO 16135, ISO 16136, ISO 16137, ISO 16138, ISO 16139 or ISO 21787, as applicable, depending on the valve type.

## Annex A (normative)

### Specific characteristics and requirements for industrial piping systems made from polybutene (PB)

#### A.1 Material

##### A.1.1 Material for components

The material shall be tested in accordance with 5.2 at 20 °C, 60 °C to 82 °C and 95 °C as well as at various hydrostatic (hoop) stresses in such a way that, at each temperature, at least three failure times fall in each of the following time intervals:

- 10 h to 100 h;
- 100 h to 1 000 h;
- 1 000 h to 8 760 h;
- > 8 760 h.

In tests lasting more than 8 760 h, any time reached which corresponds to a point on or above the relevant reference curve may be considered as a failure time.

The values of the minimum required hydrostatic strength (see reference curves given in Figure A.1) in the temperature range of 10 °C to 110 °C were calculated using equations (A.1) and (A.2). The dotted sections of the curves for 80 °C, 90 °C, 95 °C and 110 °C represent the extrapolation of the curves, applicable when longer failure times are obtained at these temperatures.

First branch (i.e. the left-hand part of each curve shown in Figure A.1):

$$\log t = -430,866 - 125\,010,0 \times \frac{\log \sigma}{T} + 173\,892,7 \times \frac{1}{T} + 290,056\,9 \times \log \sigma \quad (\text{A.1})$$

Second branch (i.e. the right-hand part of each curve shown in Figure A.1):

$$\log t = -129,895 - 37\,262,7 \times \frac{\log \sigma}{T} + 52\,556,48 \times \frac{1}{T} + 88,567\,35 \times \log \sigma \quad (\text{A.2})$$

NOTE The calculation is given in more detail in ISO 12230.



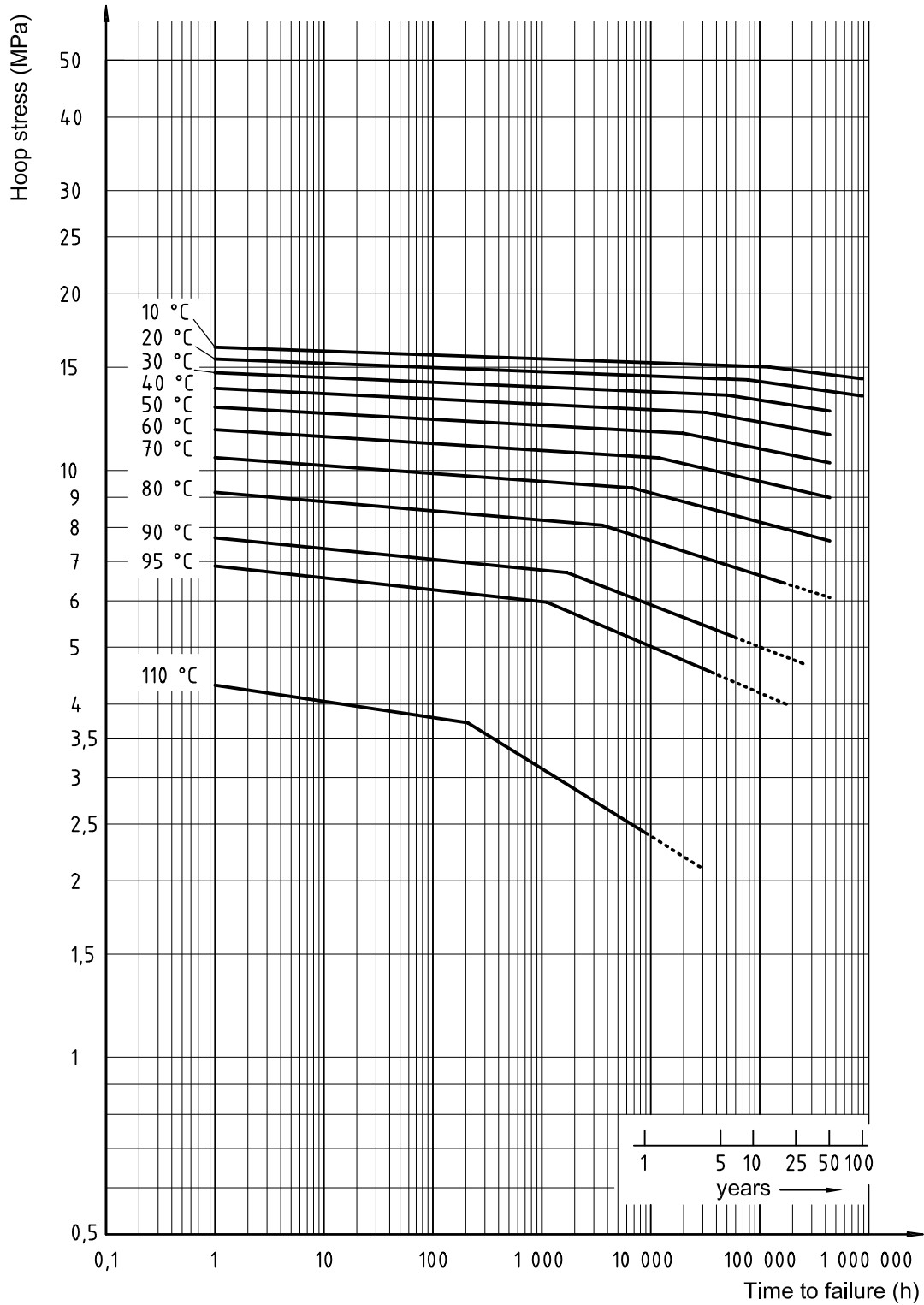

Figure A.1 — Minimum required hydrostatic strength curves for PB

**A.1.2 MRS-value**

When evaluated in accordance with 5.2, PB material shall have an MRS at least equal to 12,5 MPa.

**A.1.3 Other characteristics of material**

The material from which the components are manufactured shall conform to the requirements given in Table A.1.

**Table A.1 — Material characteristics of PB**

Characteristic	Requirement <sup>a</sup>	Test parameters		Test method
Melt mass-flow rate (MFR)	MFR ≤ 3,0 g/10 min	Temperature Load	190 °C 5 kg	ISO 1133
Pigment dispersion	≤ Grade 3	Preparation of test pieces	Compression or microtome procedure <sup>b</sup>	ISO 13949
Thermal stability assessed by determining resistance to internal pressure at 110 °C <sup>c</sup>	No failure during test period	End caps  Orientation Conditioning period Type of test Hydrostatic (hoop) stress Test temperature Test period	Type A as specified in ISO 1167:1996  Not specified As specified in ISO 1167 Water-in-air 2,4 MPa 110 °C 8 760 h	ISO 1167
<sup>a</sup> Conformity to these requirements shall be declared by the raw-material producer. <sup>b</sup> In cases of dispute, the compression procedure shall be used. <sup>c</sup> Carried out as a type test only. The results from assessment in accordance with ISO 9080 shall be taken into account.				

**A.1.4 Crystallization**

Due to the slow crystallization and shrinkage which take place after PB has been cooled from the molten state, physical and mechanical testing shall be delayed after extrusion or moulding for a period of at least 10 days at a temperature of (20 ± 5) °C.

**A.2 General characteristics — Colour**

Components made from PB should preferably be grey (RAL 7032)<sup>3)</sup>. Other colours shall be agreed on between manufacturer and purchaser.

**A.3 Geometrical characteristics**

**A.3.1 Dimensions of pipes**

**A.3.1.1 Diameters and associated tolerances**

The mean outside diameter,  $d_{em}$ , determined as the average value of measurements made at distances of  $d_n$  and  $0,1d_n$  from the end of the test piece, shall be as specified in Table A.2.

3) RAL colour cards are obtainable from national standards institutes.

### A.3.1.2 Out-of-roundness

The out-of-roundness, measured at the point of manufacture, shall be as specified in Table A.2. If values for the out-of-roundness other than those given in Table A.2 are necessary, they shall be agreed on between manufacturer and purchaser.

**Table A.2 — Mean outside diameters, associated tolerances and out-of-roundness of pipes**

Dimensions in millimetres

Nominal outside diameter $d_n$	Mean outside diameter $d_{em}$ min.	Tolerance on outside diameter <sup>a</sup>	Out-of-roundness <sup>b</sup> (straight pipes) max.
12	12,0	+ 0,3	1,0
16	16,0	+ 0,3	1,0
20	20,0	+ 0,3	1,0
25	25,0	+ 0,3	1,0
32	32,0	+ 0,3	1,0
40	40,0	+ 0,4	1,0
50	50,0	+ 0,5	1,2
63	63,0	+ 0,6	1,6
75	75,0	+ 0,7	1,8
90	90,0	+ 0,9	2,2
110	110,0	+ 1,0	2,7
125	125,0	+ 1,2	3,0
140	140,0	+ 1,3	3,4
160	160,0	+ 1,5	3,9

<sup>a</sup> The tolerances correspond to Grade A of ISO 11922-1:1997.

<sup>b</sup> The tolerances correspond to Grade M of ISO 11922-1:1997.

**A.3.1.3 Wall thicknesses and associated tolerances**

The wall thickness, *e*, and the associated tolerance shall be as specified in Table A.3.

Components which are intended to be welded shall have a wall thickness of at least 1,9 mm.

**Table A.3 — Wall thicknesses and associated tolerances**

Dimensions in millimetres

Nominal outside diameter <i>d<sub>n</sub></i>	Wall thickness, <i>e</i> , and related tolerance <sup>a</sup>											
	Pipe series S and standard dimension ratio SDR											
	S 10 SDR 21		S 8 SDR 17		S 6,3 SDR 13,6		S 5 SDR 11		S 4 SDR 9		S 3,2 SDR 7,4	
	<i>e</i> min.	b	<i>e</i> min.	b	<i>e</i> min.	b	<i>e</i> min.	b	<i>e</i> min.	b	<i>e</i> min.	b
12	1,3 <sup>c</sup>	+ 0,4	1,3 <sup>c</sup>	+ 0,4	1,3 <sup>c</sup>	+ 0,4	1,3 <sup>c</sup>	+ 0,4	1,4	+ 0,4	1,7	+ 0,4
16	1,3	+ 0,4	1,3	+ 0,4	1,3	+ 0,4	1,5	+ 0,4	1,8	+ 0,4	2,2	+ 0,5
20	1,3	+ 0,4	1,3	+ 0,4	1,5	+ 0,4	1,9	+ 0,4	2,3	+ 0,5	2,8	+ 0,5
25	1,3	+ 0,4	1,5	+ 0,4	1,9	+ 0,4	2,3	+ 0,5	2,8	+ 0,5	3,5	+ 0,6
32	1,6	+ 0,4	1,9	+ 0,4	2,4	+ 0,5	2,9	+ 0,5	3,6	+ 0,6	4,4	+ 0,7
40	1,9	+ 0,4	2,4	+ 0,5	3,0	+ 0,5	3,7	+ 0,6	4,5	+ 0,7	5,5	+ 0,8
50	2,4	+ 0,5	3,0	+ 0,5	3,7	+ 0,6	4,6	+ 0,7	5,6	+ 0,8	6,9	+ 0,9
63	3,0	+ 0,5	3,8	+ 0,6	4,7	+ 0,7	5,8	+ 0,8	7,1	+ 1,0	8,6	+ 1,1
75	3,6	+ 0,6	4,5	+ 0,7	5,6	+ 0,8	6,8	+ 0,9	8,4	+ 1,1	10,3	+ 1,3
90	4,3	+ 0,7	5,4	+ 0,8	6,7	+ 0,9	8,2	+ 1,1	10,1	+ 1,3	12,3	+ 1,5
110	5,3	+ 0,8	6,6	+ 0,9	8,1	+ 1,1	10,0	+ 1,2	12,3	+ 1,5	15,1	+ 1,8
125	6,0	+ 0,8	7,4	+ 1,0	9,2	+ 1,2	11,4	+ 1,4	14,0	+ 1,6	17,1	+ 2,0
140	6,7	+ 0,9	8,3	+ 1,1	10,3	+ 1,3	12,7	+ 1,5	15,7	+ 1,8	19,2	+ 2,2
160	7,7	+ 1,0	9,5	+ 1,2	11,8	+ 1,4	14,6	+ 1,7	17,9	+ 2,0	21,9	+ 2,4

<sup>a</sup> All dimensions correspond to those given in ISO 4065.

<sup>b</sup> The tolerances have been calculated from the expression (0,1*e* + 0,2) mm and rounded up to the nearest 0,1 mm.

<sup>c</sup> A non-preferred wall thickness of 1,1 mm is also permitted.

**A.3.2 Dimensions of fittings**

**A.3.2.1 General**

This annex is applicable to the following types of fitting:

- socket fusion fittings;
- electrofusion fittings
- flange adaptors and loose backing flanges;
- mechanical fittings.

### A.3.2.2 Socket fusion fittings

#### A.3.2.2.1 Types of socket fusion fitting

Socket fusion fittings (see Figure A.2) shall be classified as one of two types, as follows:

- **Type A:** Fittings intended to be used with pipes having dimensions as given in A.3.1 where no machining of the outside surface of the pipe is required.
- **Type B:** Fittings intended to be used with pipes having dimensions as given in A.3.1 where machining of the outside surface of the pipe is necessary in accordance with the manufacturer's instructions.

#### A.3.2.2.2 Diameters and lengths of sockets

The nominal outside diameter(s),  $d_n$ , of a socket fusion fitting shall correspond to, and be designated by, the nominal outside diameter(s) of the pipe(s) for which it is designed.

The diameters and lengths of sockets of type A socket fusion fittings shall be as specified in Table A.4. For type B socket fusion fittings, the socket diameters and lengths shall be as specified in Table A.5.

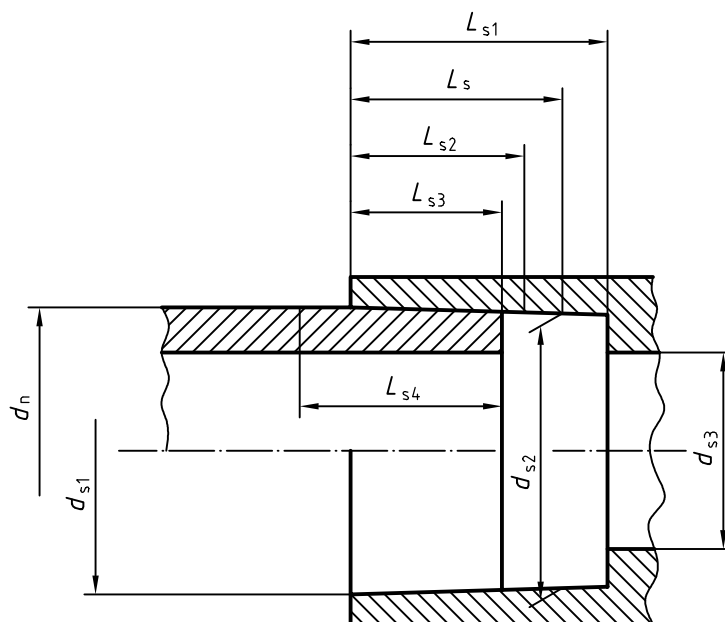

#### Key

- $d_n$  nominal outside diameter
- $d_{s1}$  inside diameter of socket mouth
- $d_{s2}$  inside diameter of socket root, i.e. the inside diameter of a circular plane parallel to the plane of the socket mouth and located a distance  $L_s$  (the reference socket length) from the socket mouth
- $d_{s3}$  minimum diameter of flow channel (bore) through body of fitting
- $L_s$  reference socket length, i.e. the theoretical minimum socket length used for calculation purposes
- $L_{s1}$  actual length of socket, i.e. the distance from the socket mouth to the shoulder, if any
- $L_{s2}$  heated length of socket, i.e. the depth of penetration of the heated tool into the socket
- $L_{s3}$  insertion length, i.e. the depth of penetration of the pipe into the socket
- $L_{s4}$  heated length of pipe, i.e. the depth of penetration of the pipe into the heated tool

Figure A.2 — Diameters and lengths of socket fusion fittings

Table A.4 — Diameters and lengths of sockets of type A socket fusion fittings

Dimensions in millimetres

Nominal outside diameter of pipe $d_n$	Mean outside diameter of pipe $d_{em}$ min.	Mean inside diameter				Out-of-roundness max.	Bore $d_{s3}$ <sup>a</sup> min.	Reference socket length $L_s$ <sup>b,c</sup> min.	Heated socket length		Penetration of pipe into socket $L_{s3}$ <sup>e,f</sup>	
		Socket mouth $d_{s1m}$		Socket root $d_{s2m}$					min.	max.	min.	max.
		min.	g	min.	g						min.	max.
16	16,0	15,0	+ 0,5	14,8	+ 0,5	0,55	9,0	13,3	10,8	13,3	9,8	12,3
20	20,0	19,0	+ 0,5	18,8	+ 0,5	0,55	13,0	14,5	12,0	14,5	11,0	13,5
25	25,0	23,8	+ 0,6	23,5	+ 0,6	0,65	18,0	16,0	13,5	16,0	12,5	15,0
32	32,0	30,7	+ 0,6	30,4	+ 0,6	0,65	25,0	18,1	15,6	18,1	14,6	17,1
40	40,0	38,7	+ 0,6	38,3	+ 0,6	0,65	31,0	20,5	18,0	20,5	17,0	19,5
50	50,0	48,7	+ 0,6	48,3	+ 0,6	0,75	39,0	23,5	21,0	23,5	20,0	22,5
63	63,0	61,6	+ 0,6	61,1	+ 0,6	0,75	49,0	27,4	24,9	27,4	23,9	26,4
75	75,0	73,2	+ 0,8	71,9	+ 0,8	1,00	58,2	31,0	28,5	31,0	27,5	30,0
90	90,0	87,8	+ 1,0	86,4	+ 1,0	1,20	69,8	35,5	33,0	35,5	32,0	34,5
110	110,0	107,3	+ 1,2	105,8	+ 1,0	1,40	85,4	41,5	39,0	41,5	38,0	40,5

- a Only applicable if a shoulder exists.
- b Reference socket length  $L_s = 0,3d_n + 8,5$  mm.
- c Actual length of socket  $L_{s1} \geq L_s$ .
- d Heated socket length  $L_{s2} \geq L_{s3} + 1,0$  mm:  
 Minimum heated socket length  $L_{s2,min} = L_s - 2,5$  mm.  
 Maximum heated socket length  $L_{s2,max} = L_s$ .
- e Minimum penetration of pipe into socket  $L_{s3,min} = L_s - 3,5$  mm.  
 Maximum penetration of pipe into socket  $L_{s3,max} = L_s - 1,0$  mm.
- f Heated length of pipe  $L_{s4} \geq L_{s3}$ .
- g Tolerances rounded up to the nearest 0,1 mm.

Table A.5 — Diameters and lengths of sockets of type B socket fusion fittings

Dimensions in millimetres

Nominal outside diameter of pipe $d_n$	Mean outside diameter of pipe $d_{em}$		Mean inside diameter				Out-of-roundness max.	Bore $d_{s3}^a$ min.	Reference socket length $L_s^{b,c}$ min.	Heated socket length		Penetration of pipe into socket	
			Socket mouth $d_{s1m}$		Socket root $d_{s2m}$					$L_{s2}^d$	$L_{s3}^{e,f}$		
			min.	max.	min.	g						min.	max.
16	15,8	16,0	15,0	+ 0,5	14,8	+ 0,5	0,55	9,0	13,3	10,8	13,3	9,8	12,3
20	19,8	20,0	19,0	+ 0,5	18,8	+ 0,5	0,55	13,0	14,5	12,0	14,5	11,0	13,5
25	24,8	25,0	23,8	+ 0,6	23,5	+ 0,6	0,65	18,0	16,0	13,5	16,0	12,5	15,0
32	31,8	32,0	30,7	+ 0,6	30,4	+ 0,6	0,65	25,0	18,1	15,6	18,1	14,6	17,1
40	39,8	40,0	38,7	+ 0,6	38,3	+ 0,6	0,65	31,0	20,5	18,0	20,5	17,0	19,5
50	49,8	50,0	48,7	+ 0,6	48,3	+ 0,6	0,75	39,0	23,5	21,0	23,5	20,0	22,5
63	62,7	63,0	61,6	+ 0,6	61,1	+ 0,6	0,75	49,0	27,4	24,9	27,4	23,9	26,4
75	74,7	75,0	72,6	+ 0,6	72,3	+ 0,6	1,00	58,2	31,0	28,5	31,0	27,5	30,0
90	89,7	90,0	87,1	+ 0,7	86,7	+ 0,7	1,20	69,8	35,5	33,0	35,5	32,0	34,5
110	109,6	110,0	106,3	+ 0,8	105,7	+ 0,8	1,40	85,4	41,5	39,0	41,5	38,0	40,5

<sup>a</sup> Only applicable if a shoulder exists.

<sup>b</sup> Reference socket length  $L_s = 0,3d_n + 8,5$  mm.

<sup>c</sup> Actual length of socket  $L_{s1} \geq L_s$ .

<sup>d</sup> Heated socket length  $L_{s2} \geq L_{s3} + 1,0$  mm.

Minimum heated socket length  $L_{s2,min} = L_s - 2,5$  mm.

Maximum heated socket length  $L_{s2,max} = L_s$ .

<sup>e</sup> Minimum penetration of pipe into socket  $L_{s3,min} = L_s - 3,5$  mm.

Maximum penetration of pipe into socket  $L_{s3,max} = L_s - 1,0$  mm.

<sup>f</sup> Heated length of pipe  $L_{s4} \geq L_{s3}$ .

<sup>g</sup> Tolerances rounded up to the nearest 0,1 mm.

### A.3.2.2.3 Other dimensions

Other dimensions of socket fusion fittings shall be as specified by the manufacturer.

### A.3.2.3 Electrofusion fittings

#### A.3.2.3.1 Dimensions of sockets of electrofusion fittings

The dimensions of electrofusion fitting sockets (see Figure A.3) shall be as specified in Table A.6.

In the cases of fittings having sockets of different sizes (e.g. reduction fittings), each socket shall conform to the requirements for the nominal diameter of that socket.

In the cases of spigot end fittings, the outside length of the tubular part of the fusion-jointing end shall allow assembly with an electrofusion fitting.

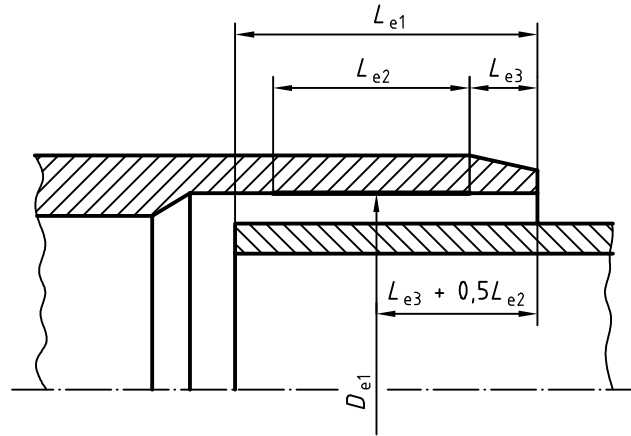

- Key**
- $D_{e1}$  inside diameter in fusion zone measured in a plane parallel to the plane of the mouth at a distance  $L_{e3} + 0,5L_{e2}$  from that plane
  - $L_{e1}$  depth of penetration of pipe or male end of a spigot fitting (in the case of a socket without a stop, this distance shall be not greater than half the total length of the fitting)
  - $L_{e2}$  heated length of socket, i.e. the nominal length of the fusion zone as declared by the manufacturer
  - $L_{e3}$  distance between mouth of socket and start of fusion zone, i.e. the nominal unheated length at the mouth of the socket as declared by the manufacturer ( $L_{e3}$  shall be  $\geq 5$  mm)

**Figure A.3 — Dimensions of sockets of electrofusion fittings**

**Table A.6 — Dimensions of sockets of electrofusion fittings**

Dimensions in millimetres

Nominal diameter of fitting $d_n$	Mean inside diameter in fusion zone $D_{e1m}^a$	Depth of penetration $L_{e1}$		Length of fusion zone $L_{e2}$
		min.	max.	
16	16,1	20	41	10
20	20,1	20	41	10
25	25,1	20	41	10
32	32,1	20	44	10
40	40,1	20	49	10
50	50,1	20	55	10
63	63,2	23	63	11
75	75,2	25	70	12
90	90,2	28	79	13
110	110,3	32	85	15
125	125,3	35	90	16
140	140,3	38	95	18
160	160,4	42	101	20

<sup>a</sup> The manufacturer shall declare the actual maximum and minimum values of  $D_{e1}$  and  $L_{e1}$  to determine the suitability of the fitting for clamping and joint assembly.

**A.3.2.3.2 Other dimensions**

Other dimensions of electrofusion fittings shall be as specified by the manufacturer.



### A.3.2.4 Flange adaptors and loose backing flanges

#### A.3.2.4.1 Dimensions of flange adaptors for socket fusion

The dimensions of flange adaptors for socket fusion (see Figure A.4) shall be as specified in Table A.7.

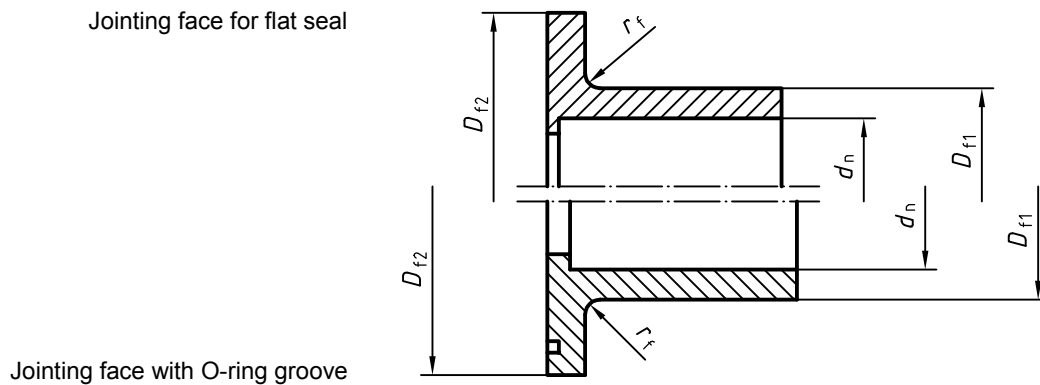

Figure A.4 — Dimensions of flange adaptors for socket fusion

Table A.7 — Dimensions of flange adaptors for socket fusion

Dimensions in millimetres

Nominal outside diameter of corresponding pipe	Outside diameter of chamfer on shoulder	Outside diameter of flange adaptor	Radius of chamfer on shoulder
$d_n$	$D_{f1}$	$D_{f2}$	$r_f$
16	22	40	3
20	27	45	3
25	33	58	3
32	41	68	3
40	50	78	3
50	61	88	3
63	76	102	4
75	90	122	4
90	108	138	4
110	131	158	4

**A.3.2.4.2 Dimensions of loose backing flanges for use with flange adaptors for socket fusion**

The dimensions of loose backing flanges for use with flange adaptors for socket fusion (see Figure A.5) shall be as specified in Table A.8.

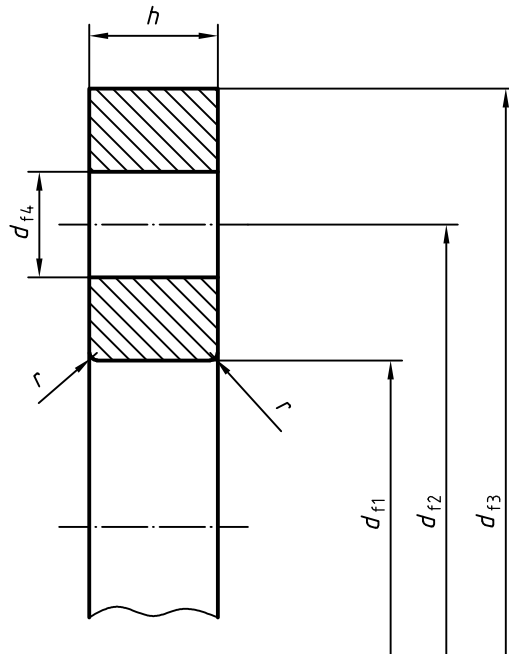

NOTE The thickness,  $h$ , of the loose backing flange is dependent on the material used.

**Figure A.5 — Dimensions of loose backing flanges for use with flange adaptors for socket fusion**

**Table A.8 — Dimensions of loose backing flanges for use with flange adaptors for socket fusion**

Dimensions in millimetres

Nominal outside diameter of corresponding pipe	Nominal size of flange	Inside diameter of flange	Pitch circle diameter of bolt holes	Outside diameter of flange	Diameter of bolt holes	Radius of flange	Number of bolt holes	Metric thread of bolt
$d_n$	DN	$d_{f1}$	$d_{f2}$	$d_{f3}$ min.	$d_{f4}$	$r$		
16	10	23	60	90	14	3	4	M12
20	15	28	65	95	14	3	4	M12
25	20	34	75	105	14	3	4	M12
32	25	42	85	115	14	3	4	M12
40	32	51	100	140	18	3	4	M16
50	40	62	110	150	18	3	4	M16
63	50	78	125	165	18	3	4	M16
75	65	92	145	185	18	3	4	M16
90	80	110	160	200	18	3	8	M16
110	100	133	180	220	18	3	8	M16

## A.4 Mechanical characteristics

### A.4.1 Mechanical characteristics of pipes and fittings

When tested as specified in Table A.9 under the test conditions indicated, using the test set-up indicated in Table A.10, components shall withstand the hydrostatic stress without bursting or leakage.

NOTE The internal pressure to be used is calculated as indicated in 8.2.

**Table A.9 — Requirements for internal-pressure testing**

Characteristic	Requirement	Test conditions		Test method <sup>a</sup>
		Hydrostatic (hoop) stress MPa	Time h	
Resistance to internal pressure at 20 °C	No failure during test period	15,5	≥ 1	ISO 1167 ISO 12092
Resistance to internal pressure at 95 °C		6,2	≥ 165	ISO 1167 ISO 12092
Resistance to internal pressure at 95 °C		6,0	≥ 1 000	ISO 1167 ISO 12092

<sup>a</sup> Fittings shall be prepared in accordance with ISO 12092 and tested in accordance with ISO 1167.

**Table A.10 — Test set-up**

End caps	Type A as specified in ISO 1167:1996
Orientation	Not specified
Conditioning period	≥ 1 h
Type of test	Water-in-water or water-in-air <sup>a</sup>
<sup>a</sup> In cases of dispute, water-in-water shall be used.	

### A.4.2 Mechanical characteristics of valves

Valves shall conform to the requirements of ISO 16135, ISO 16136, ISO 16137, ISO 16138, ISO 16139 or ISO 21787, as applicable, depending on the valve type.

## A.5 Physical characteristics

### A.5.1 Physical characteristics of pipes

When determined in accordance with the test methods specified in Table A.11, using the parameters indicated, the physical characteristics of pipes shall conform to the requirements given in Table A.11.

**Table A.11 — Physical characteristics of pipes**

Characteristic	Requirement	Test parameters		Test method
Melt mass-flow rate (MFR)	When processing the material into a pipe, the MFR-value specified by the raw-material producer may deviate by, at the most, $\pm 0,3$ g/10 min from the value for the raw material	Temperature Load	190 °C 5 kg	ISO 1133
Longitudinal reversion <sup>a</sup>	$\leq 2\%$  The pipe shall exhibit no bubbles or cracks	Temperature Immersion time: $e \leq 8$ mm $8 \text{ mm} < e \leq 16$ mm $e > 16$ mm Length of test piece	110 °C  30 min 60 min 120 min 200 mm	ISO 2505-1:1994 together with ISO 2505-2:1994  Method A: Liquid bath
		or		
		Temperature Immersion time: $e \leq 8$ mm $8 \text{ mm} < e \leq 16$ mm $e > 16$ mm Length of test piece	110 °C  60 min 120 min 240 min 200 mm	ISO 2505-1:1994 together with ISO 2505-2:1994  Method B: Air
<sup>a</sup> The choice between method A and method B is free. In cases of dispute, however, method A shall be used.				

### A.5.2 Physical characteristics of fittings

When determined in accordance with the test method specified in Table A.12, using the parameters indicated, the physical characteristics of fittings shall conform to the requirements given in Table A.12.

**Table A.12 — Physical characteristics of fittings**

Characteristic	Requirement	Test parameters		Test method
Melt mass-flow rate (MFR)	When processing the material into a pipe, the MFR-value specified by the raw-material producer may deviate by, at the most, $\pm 0,3$ g/10 min from the value for the raw material	Temperature Load	190 °C 5 kg	ISO 1133

### A.5.3 Physical characteristics of valves

In addition to the requirements of ISO 16135, ISO 16136, ISO 16137, ISO 16138, ISO 16139 or ISO 21787, as applicable, depending on the valve type, valves shall conform to A.5.2.

## A.6 Fitness for purpose of the system

The fitness for purpose of the system shall be deemed to apply when test assemblies, assembled in accordance with 12.2 and tested using the test methods and parameters specified in Table A.13, conform to the requirements given in Table A.13.

**Table A.13 — General requirements for fitness for purpose of the system**

Characteristic	Requirement	Test parameters		Test method <sup>a</sup>
Hydrostatic strength at 95 °C	No failure during test period	End caps	Type A as specified in ISO 1167:1996	ISO 1167 and ISO 12092
		Orientation	Not specified	
		Test temperature	95 °C	
		Type of test	Water-in-water or water-in-air <sup>b</sup>	
		Hydrostatic (hoop) stress	6,0 MPa	
		Conditioning period	≥ 1 h	
		Test period	≥ 1 000 h	
<sup>a</sup> Assemblies of pipes and fittings shall be prepared in accordance with ISO 12092 and tested in accordance with ISO 1167.				
<sup>b</sup> In cases of dispute, water-in-water shall be used.				

## Annex B (normative)

### Specific characteristics and requirements for industrial piping systems made from polyethylene (PE)

#### B.1 Material

##### B.1.1 General

This annex is applicable to the following types of polyethylene:

- PE 63 polyethylene;
- PE 80 polyethylene;
- PE 100 polyethylene.

##### B.1.2 Material for components

The material shall be tested in accordance with 5.2 at 20 °C, 60 °C and 80 °C as well as at various hydrostatic (hoop) stresses in such a way that, at each temperature, at least three failure times fall in each of the following time intervals:

- 10 h to 100 h;
- 100 h to 1 000 h;
- 1 000 h to 8 760 h;
- > 8 760 h.

In tests lasting more than 8 760 h, any time reached which corresponds to a point on or above the relevant reference curve may be considered as a failure time.

The values of the minimum required hydrostatic strength [see reference curves given in Figure B.1 (PE 63), Figure B.2 (PE 80) and Figure B.3 (PE 100)] in the temperature range of 10 °C to 80 °C were calculated using equations (B.1) to (B.6).

First branch (i.e. the left-hand part of each curve shown in Figures B.1, B.2 and B.3):

$$\text{PE 63: } \log t = -41,417\ 3 + 22\ 008,572\ 2 \times \frac{1}{T} - 35,098\ 7 \times \log \sigma \quad (\text{B.1})$$

$$\text{PE 80: } \log t = -40,957\ 8 + 23\ 596,349\ 5 \times \frac{1}{T} - 37,575\ 8 \times \log \sigma \quad (\text{B.2})$$

$$\text{PE 100: } \log t = -38,937\ 5 + 24\ 482,467 \times \frac{1}{T} - 38,978\ 9 \times \log \sigma \quad (\text{B.3})$$



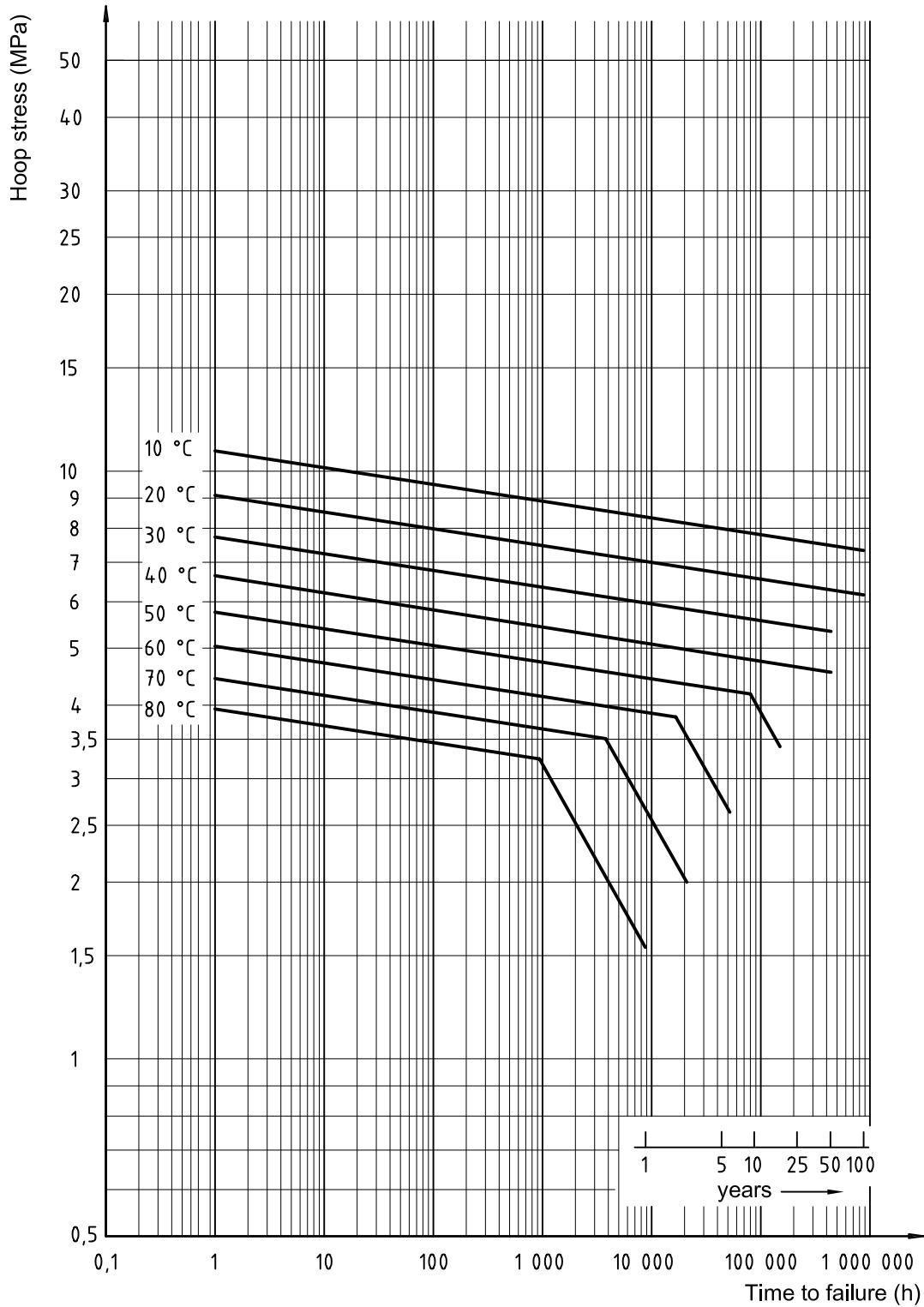

Figure B.1 — Minimum required hydrostatic strength curves for PE 63



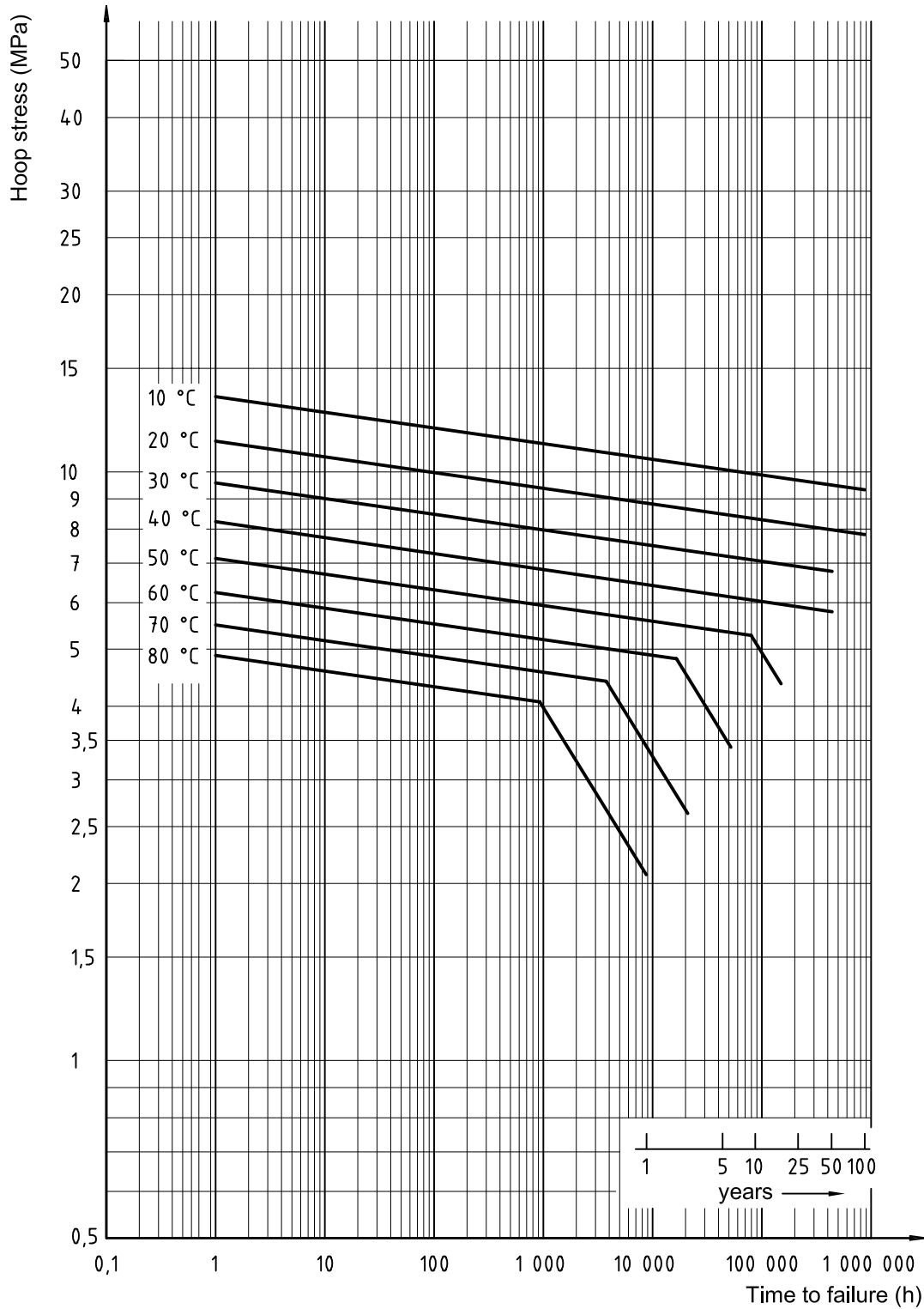

Figure B.2 — Minimum required hydrostatic strength curves for PE 80

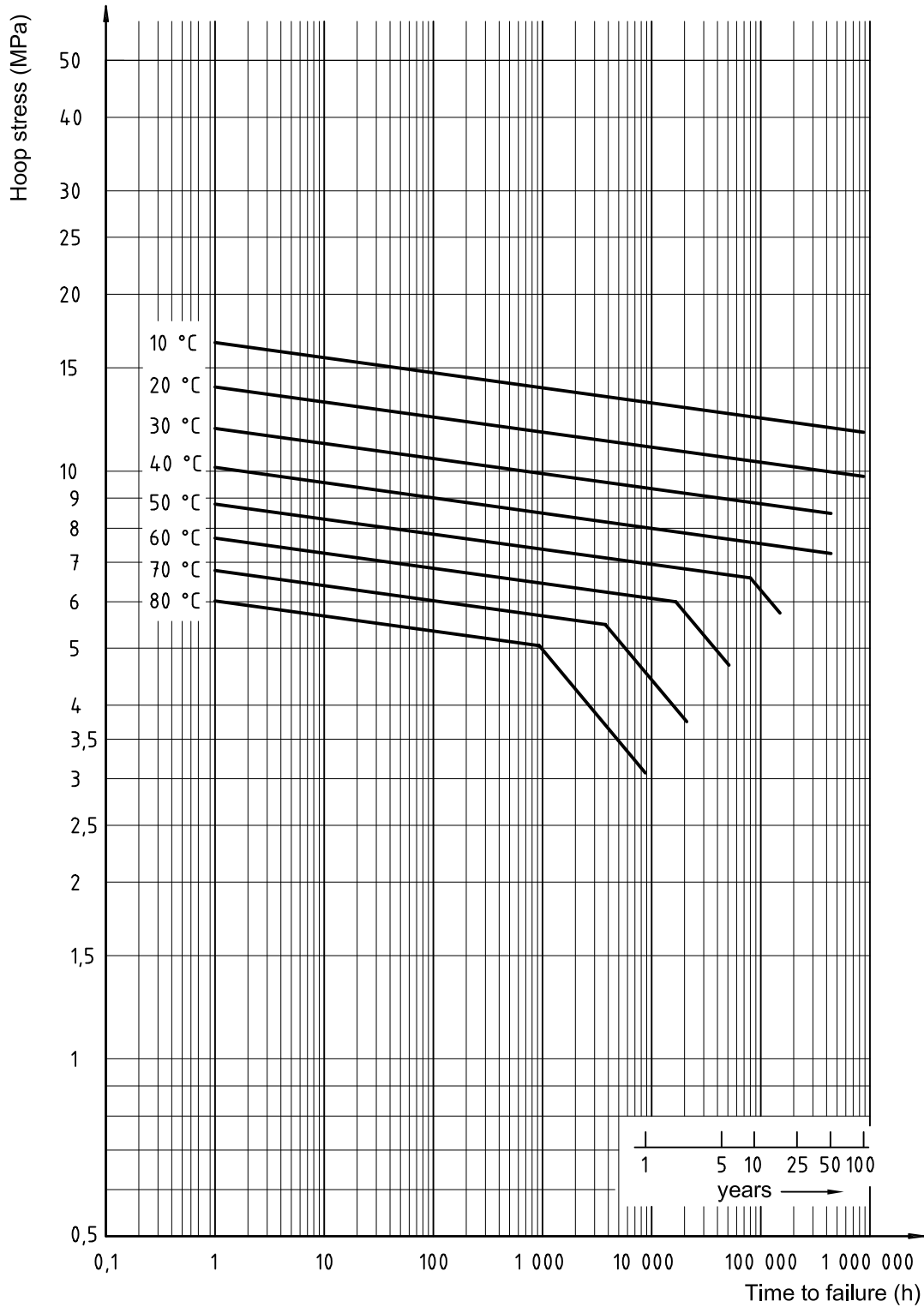

Figure B.3 — Minimum required hydrostatic strength curves for PE 100

### B.1.3 MRS-value

When evaluated in accordance with 5.2, PE material shall have an MRS as given in Table B.1.

**Table B.1 — MRS-values of different types of PE**

PE type	MRS-value MPa
PE 63	≥ 6,3
PE 80	≥ 8,0
PE 100	≥ 10,0

### B.1.4 Other characteristics of material

The material from which the components are manufactured shall conform to the requirements given in Table B.2.

**Table B.2 — Material characteristics of PE**

Characteristic	Requirement <sup>a</sup>	Test parameters		Test method
Density	≥ 930 kg/m <sup>3</sup> (base polymer)	Test temperature	23 °C	ISO 1183:1987 Method D
Thermal stability	OIT ≥ 20 min	Test temperature <sup>b</sup>	200 °C	ISO/TR 10837
Melt mass-flow rate (MFR)	(0,2 ≤ MFR ≤ 1,7) g/10 min	Temperature Load	190 °C 5 kg	ISO 1133
Carbon black content <sup>c</sup>	2,0 % to 2,5 % by mass	As specified in ISO 6964		ISO 6964
Pigment dispersion <sup>d</sup>	≤ Grade 3	Preparation of test pieces	Compression or microtome procedure <sup>e</sup>	ISO 13949
Resistance to rapid crack propagation <sup>f,g</sup> (critical pressure, $p_c$ ) ( $e \geq 15$ mm)	$p_c \geq 1,5 \times \text{MOP}^h$ where $p_c = 3,6p_{c,S4} + 2,6$	Test temperature	0 °C	ISO 13477

<sup>a</sup> Conformity to these requirements shall be declared by the raw-material producer.

<sup>b</sup> Test may be carried out at 210 °C, providing there is a clear correlation with the results at 200 °C. In cases of dispute, the test shall be carried out at 200 °C.

<sup>c</sup> Only for black material.

<sup>d</sup> For black and non-black material.

<sup>e</sup> In cases of dispute, the compression procedure shall be used.

<sup>f</sup> Only applicable to material intended for components for the conveyance of compressed gases.

<sup>g</sup> The material shall be tested in the form of a pipe.

<sup>h</sup> The correlation factor for full-scale/S4 is equal to 3,6. It is defined as follows:

$$(p_{c,\text{full scale}} + 1) = 3,6(p_{c,S4} + 1)$$

Attention is drawn to the fact that the correlation factor may be subject to modification when this International Standard is revised.

If the requirement is not met or test equipment for the S4 test is not available, then (re)testing using the full-scale test shall be performed in accordance with ISO 13478. In this case, the value of  $p_{c,\text{full scale}}$  shall be taken as the value of  $p_c$ .

## B.2 General characteristics — Colour

Components made from PE should preferably be black. Other colours shall be agreed on between manufacturer and purchaser.

## B.3 Geometrical characteristics

### B.3.1 Dimensions of pipes

#### B.3.1.1 Diameters and associated tolerances

The mean outside diameter,  $d_{em}$ , determined as the average value of measurements made at distances of  $d_n$  and  $0,1d_n$  from the end of the test piece, shall be as specified in Table B.3.

NOTE Pipes with Grade A tolerances are used for socket fusion and electrofusion joints where the peeling technique is used to prepare the pipe end for fusion jointing. Pipes with Grade B tolerances are used for socket fusion joints where the peeling technique is not used.

#### B.3.1.2 Out-of-roundness

The out-of-roundness of straight lengths, measured at the point of manufacture, shall be as specified in Table B.3. If values for the out-of-roundness other than those given in Table B.3 are necessary, they shall be agreed on between manufacturer and purchaser.

For coiled pipes, the maximum out-of-roundness shall be specified by agreement between manufacturer and purchaser.

Table B.3 — Mean outside diameters, associated tolerances and out-of-roundness of pipes

Dimensions in millimetres

Nominal outside diameter $d_n$	Mean outside diameter $d_{em}$ min.	Tolerance on outside diameter		Out-of-roundness (straight pipes) Grade N <sup>a</sup> max.
		Grade A <sup>a</sup>	Grade B <sup>a</sup>	
16	16,0	+ 0,3	+ 0,3	1,2
20	20,0	+ 0,3	+ 0,3	1,2
25	25,0	+ 0,3	+ 0,3	1,2
32	32,0	+ 0,3	+ 0,3	1,3
40	40,0	+ 0,4	+ 0,4 <sup>b</sup>	1,4
50	50,0	+ 0,5	+ 0,4 <sup>b</sup>	1,4
63	63,0	+ 0,6	+ 0,4	1,5
75	75,0	+ 0,7	+ 0,5	1,6
90	90,0	+ 0,9	+ 0,6	1,8
110	110,0	+ 1,0	+ 0,7	2,2
125	125,0	+ 1,2	+ 0,8	2,5
140	140,0	+ 1,3	+ 0,9	2,8
160	160,0	+ 1,5	+ 1,0	3,2
180	180,0	+ 1,7	+ 1,1	3,6
200	200,0	+ 1,8	+ 1,2	4,0
225	225,0	+ 2,1	+ 1,4	4,5
250	250,0	+ 2,3	+ 1,5	5,0
280	280,0	+ 2,6	+ 1,7	9,8
315	315,0	+ 2,9	+ 1,9	11,1
355	355,0	+ 3,2	+ 2,2	12,5
400	400,0	+ 3,6	+ 2,4	14,0
450	450,0	+ 4,1	+ 2,7	15,8 <sup>b</sup>
500	500,0	+ 4,5	+ 3,0	17,5
560	560,0	+ 5,0	+ 3,4	19,6
630	630,0	+ 5,7	+ 3,8	22,1
710	710,0	+ 6,4	+ 4,0	24,9
800	800,0	+ 7,2	+ 4,0	28,0
900	900,0	+ 8,1	+ 4,0	31,5
1 000	1 000,0	+ 9,0	+ 4,0	35,0
1 200	1 200,0	+ 10,8 <sup>c</sup>	—	42,0
1 400	1 400,0	+ 12,6 <sup>c</sup>	—	49,0
1 600	1 600,0	+ 14,4 <sup>c</sup>	—	56,0

<sup>a</sup> In accordance with ISO 11922-1:1997.

<sup>b</sup> Not in accordance with ISO 11922-1:1997.

<sup>c</sup> Tolerance calculated as  $0,009d_{em}$  and hence not in accordance with Grade A of ISO 11922-1:1997.

**B.3.1.3 Wall thicknesses and associated tolerances**

The wall thickness, *e*, and the associated tolerance shall be as specified in Table B.4.

**Table B.4 — Wall thicknesses and associated tolerances**

Dimensions in millimetres

Nominal outside diameter <i>d<sub>n</sub></i>	Wall thickness, <i>e</i> , and associated tolerance <sup>a</sup>															
	Pipe series S and standard dimension ratio SDR															
	S 20 SDR 41		S 16 SDR 33		S 12,5 SDR 26		S 8,3 SDR 17,6		S 8 SDR 17		S 5 SDR 11		S 3,2 SDR 7,4		S 2,5 SDR 6	
	<i>e</i> min.	b	<i>e</i> min.	b	<i>e</i> min.	b	<i>e</i> min.	b	<i>e</i> min.	b	<i>e</i> min.	b	<i>e</i> min.	b	<i>e</i> min.	b
16	—	—	—	—	—	—	—	—	—	—	1,8	+0,4	2,2	+0,5	2,7	+0,5
20	—	—	—	—	—	—	1,8	+0,4	1,8	+0,4	1,9	+0,4	2,8	+0,5	3,4	+0,6
25	—	—	—	—	—	—	1,8	+0,4	1,8	+0,4	2,3	+0,5	3,5	+0,6	4,2	+0,7
32	—	—	—	—	—	—	1,9	+0,4	1,9	+0,4	2,9	+0,5	4,4	+0,7	5,4	+0,8
40	—	—	—	—	1,8	+0,4	2,3	+0,5	2,4	+0,5	3,7	+0,6	5,5	+0,8	6,7	+0,9
50	1,8	+0,4	1,8	+0,4	2,0	+0,4	2,9	+0,5	3,0	+0,5	4,6	+0,7	6,9	+0,9	8,3	+1,1
63	1,8	+0,4	2,0	+0,4	2,5	+0,5	3,6	+0,6	3,8	+0,6	5,8	+0,8	8,6	+1,1	10,5	+1,3
75	1,9	+0,4	2,3	+0,5	2,9	+0,5	4,3	+0,7	4,5	+0,7	6,8	+0,9	10,3	+1,3	12,5	+1,5
90	2,2	+0,5	2,8	+0,5	3,5	+0,6	5,1	+0,8	5,4	+0,8	8,2	+1,1	12,3	+1,5	15,0	+1,7
110	2,7	+0,5	3,4	+0,6	4,2	+0,7	6,3	+0,9	6,6	+0,9	10,0	+1,2	15,1	+1,8	18,3	+2,1
125	3,1	+0,6	3,9	+0,6	4,8	+0,7	7,1	+1,0	7,4	+1,0	11,4	+1,4	17,1	+2,0	20,8	+2,3
140	3,5	+0,6	4,3	+0,7	5,4	+0,8	8,0	+1,0	8,3	+1,1	12,7	+1,5	19,2	+2,2	23,3	+2,6
160	4,0	+0,6	4,9	+0,7	6,2	+0,9	9,1	+1,2	9,5	+1,2	14,6	+1,7	21,9	+2,4	26,6	+2,9
180	4,4	+0,7	5,5	+0,8	6,9	+0,9	10,2	+1,3	10,7	+1,3	16,4	+1,9	24,6	+2,7	29,9	+3,2
200	4,9	+0,7	6,2	+0,9	7,7	+1,0	11,4	+1,4	11,9	+1,4	18,2	+2,1	27,4	+3,0	33,2	+3,6
225	5,5	+0,8	6,9	+0,9	8,6	+1,1	12,8	+1,5	13,4	+1,6	20,5	+2,3	30,8	+3,3	37,4	+4,0
250	6,2	+0,9	7,7	+1,0	9,6	+1,2	14,2	+1,7	14,8	+1,7	22,7	+2,5	34,2	+3,7	—	—
280	6,9	+0,9	8,6	+1,1	10,7	+1,3	15,9	+1,8	16,6	+1,9	25,4	+2,8	38,3	+4,1	—	—
315	7,7	+1,0	9,7	+1,2	12,1	+1,5	17,9	+2,0	18,7	+2,1	28,6	+3,1	43,1	+4,6	—	—
355	8,7	+1,1	10,9	+1,3	13,6	+1,6	20,1	+2,3	21,1	+2,4	32,2	+3,5	48,5	+5,1	—	—
400	9,8	+1,2	12,3	+1,5	15,3	+1,8	22,7	+2,5	23,7	+2,6	36,3	+3,9	54,7	+5,7	—	—
450	11,0	+1,3	13,8	+1,6	17,2	+2,0	25,5	+2,8	26,7	+2,9	40,9	+4,3	—	—	—	—
500	12,3	+1,5	15,3	+1,8	19,2	+2,2	28,3	+3,1	29,7	+3,2	45,4	+4,8	—	—	—	—
560	13,7	+1,6	17,2	+2,0	21,4	+2,4	31,7	+3,4	33,2	+3,6	50,8	+5,3	—	—	—	—
630	15,4	+1,8	19,3	+2,2	24,1	+2,7	35,7	+3,8	37,4	+4,0	57,2	+6,0	—	—	—	—
710	17,4	+2,0	21,8	+2,4	27,2	+3,0	40,2	+4,3	42,1	+4,5	64,5	+6,7	—	—	—	—
800	19,6	+2,2	24,5	+2,7	30,6	+3,3	45,3	+4,8	47,4	+5,0	—	—	—	—	—	—
900	22,0	+2,4	27,6	+3,0	34,4	+3,7	—	—	—	—	—	—	—	—	—	—
1 000	24,5	+2,7	30,6	+3,3	38,2	+4,1	—	—	—	—	—	—	—	—	—	—
1 200	29,4	+3,2	36,7	+3,9	—	—	—	—	—	—	—	—	—	—	—	—
1 400	34,3	+3,7	42,9	+4,5	—	—	—	—	—	—	—	—	—	—	—	—
1 600	39,2	+4,2	—	—	—	—	—	—	—	—	—	—	—	—	—	—

<sup>a</sup> All dimensions correspond to those given in ISO 4065.

<sup>b</sup> The tolerances have been calculated from the expression (0,1*e* + 0,2) mm and rounded up to the nearest 0,1 mm.

## B.3.2 Dimensions of fittings

### B.3.2.1 General

This annex is applicable to the following types of fittings:

- butt fusion fittings;
- socket fusion fittings;
- electrofusion fittings;
- flange adaptors and loose backing flanges;
- mechanical fittings.

### B.3.2.2 Butt fusion fittings

#### B.3.2.2.1 Lengths and diameters of spigot ends of butt fusion fittings

The minimum inside and outside lengths,  $L_{b1}$  and  $L_{b2}$ , of spigot ends (see Figure B.4) shall be as specified in Table B.5. The mean outside diameter,  $d_{em}$ , of the spigot end over the length  $L_{b2}$  shall be as specified in B.3.1.1, except between the plane of the mouth and a plane parallel to it, at a distance not more than  $(0,01d_n + 1)$  mm, where a reduction in the outside diameter is permissible.

#### B.3.2.2.2 Out-of-roundness

The out-of-roundness of spigot ends over the length  $L_{b2}$  (see Figure B.4 and Table B.5) shall be as specified in B.3.1.2.

#### B.3.2.2.3 Wall thicknesses of spigot ends

The wall thickness,  $e$ , of spigot ends over the length  $L_{b1}$  (see Figure B.4 and Table B.5) shall be as specified in B.3.1.3, except between the plane of the mouth and a plane parallel to it, at a distance not more than  $(0,01d_n + 1)$  mm, where a reduction in the outside diameter is permissible, e.g. for a chamfered edge.

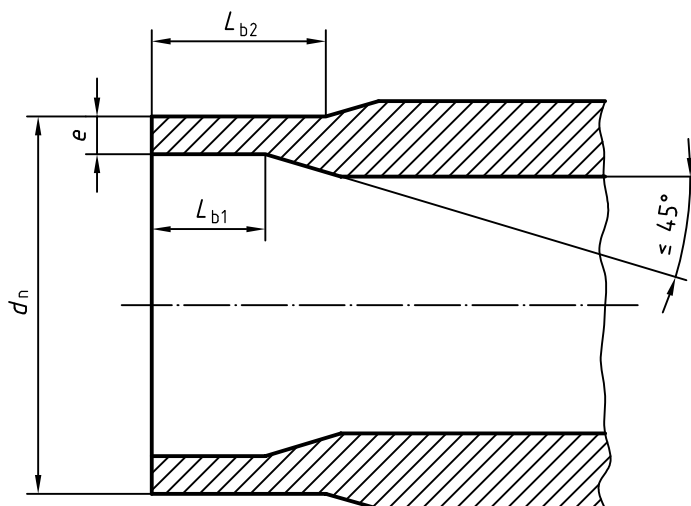

**Key**

- $L_{b1}$  inside length of spigot end
- $L_{b2}$  outside length of spigot end

**Figure B.4 — Dimensions of spigot ends of butt fusion fittings**



Table B.5 — Dimensions of spigot ends of butt fusion fittings

Dimensions in millimetres

Nominal outside diameter $d_n$	Inside length of spigot end $L_{b1}^a$ min.	Outside length of spigot end $L_{b2}^a$ min.
16	4	10
20	4	10
25	4	10
32	5	10
40	5	10
50	5	12
63	6	12
75	6	12
90	7	12
110	8	12
125	8	15
140	9	15
160	9	20
180	10	20
200	11	20
225	12	25
250	13	25
280	14	30
315	15	30
355	16	30
400	18	30
450	20	35
500	20	35
560	20	40
630	20	40
710	20	40
800	20	50
900	20	50
1 000	20	60
1 200	20	60
1 400	20	70
1 600	20	70

<sup>a</sup> For bends, a reduction in the length(s) of the tubular part(s) of the spigot end is permissible.

NOTE The minimum lengths given in this table are too short for electrofusion joints. For electrofusion jointing, a length corresponding to the depth of penetration specified in Table B.8 is necessary.

#### B.3.2.2.4 Wall thickness of fitting body

The wall thickness,  $e$ , of the fitting body shall be at least equal to the minimum wall thickness of the corresponding pipe (see B.3.1.3).

**B.3.2.2.5 Other dimensions**

Other dimensions of butt fusion fittings shall be as specified by the manufacturer.

**B.3.2.3 Socket fusion fittings**

**B.3.2.3.1 Types of socket fusion fitting**

Socket fusion fittings (see Figure B.5) shall be classified as one of two types, as follows:

- **Type A:** Fittings intended to be used with pipes having dimensions as given in B.3.1 where no machining of the outside surface of the pipe is required.
- **Type B:** Fittings intended to be used with pipes having dimensions as given in B.3.1 where machining of the outside surface of the pipe is necessary in accordance with the manufacturer's instructions.

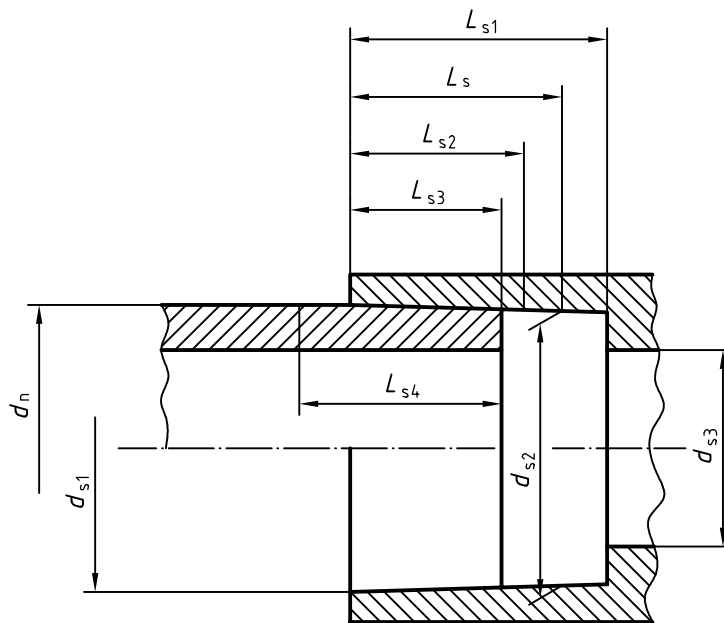

**Key**

- $d_n$  nominal outside diameter
- $d_{s1}$  inside diameter of socket mouth
- $d_{s2}$  inside diameter of socket root, i.e. the inside diameter of a circular plane parallel to the plane of the socket mouth and located a distance  $L_s$  (the reference socket length) from the socket mouth
- $d_{s3}$  minimum diameter of flow channel (bore) through body of fitting
- $L_s$  reference socket length, i.e. the theoretical minimum socket length used for calculation purposes
- $L_{s1}$  actual length of socket, i.e. the distance from the socket mouth to the shoulder, if any
- $L_{s2}$  heated length of socket, i.e. the depth of penetration of the heated tool into the socket
- $L_{s3}$  insertion length, i.e. the depth of penetration of the pipe into the socket
- $L_{s4}$  heated length of pipe, i.e. the depth of penetration of the pipe into the heated tool

**Figure B.5 — Diameters and lengths of socket fusion fittings**

**B.3.2.3.2 Diameters and lengths of sockets**

The nominal outside diameter(s),  $d_n$ , of a socket fusion fitting shall correspond to, and be designated by, the nominal outside diameter(s) of the pipe(s) for which it is designed.

The diameters and lengths of sockets of type A socket fusion fittings shall be as specified in Table B.6. For type B socket fusion fittings, the socket diameters and lengths shall be as specified in Table B.7.

**Table B.6 — Diameters and lengths of sockets of type A socket fusion fittings**

Dimensions in millimetres

Nominal outside diameter of pipe $d_n$	Mean outside diameter of pipe $d_{em}$ min.	Mean inside diameter				Out-of-roundness max.	Bore $d_{s3}^a$ min.	Reference socket length $L_s^b$ min.	Heated socket length		Penetration of pipe into socket	
		Socket mouth $d_{s1m}$		Socket root $d_{s2m}$					min.	max.	min.	max.
		min.	f	min.	f							
16	16,0	15,2	+ 0,3	15,1	+ 0,3	0,4	11,0	13,0	10,5	13,0	9,5	12,0
20	20,0	19,2	+ 0,3	19,0	+ 0,3	0,4	13,0	14,5	12,0	14,5	11,0	13,5
25	25,0	24,2	+ 0,3	23,9	+ 0,4	0,4	18,0	16,0	13,5	16,0	12,5	15,0
32	32,0	31,1	+ 0,4	30,9	+ 0,4	0,5	25,0	18,0	15,5	18,0	14,5	17,0
40	40,0	39,0	+ 0,4	38,8	+ 0,4	0,5	31,0	20,5	18,0	20,5	17,0	19,5
50	50,0	48,9	+ 0,5	48,7	+ 0,5	0,6	39,0	23,5	21,0	23,5	20,0	22,5
63	63,0	61,9	+ 0,6	61,6	+ 0,5	0,6	49,0	27,5	25,0	27,5	24,0	26,5
75	75,0	74,3	+ 0,6	73,1	+ 0,6	1,0	59,0	30,0	27,5	30,0	26,5	29,0
90	90,0	89,3	+ 0,6	87,9	+ 0,6	1,0	71,0	33,0	31,5	33,0	30,5	32,0
110	110,0	109,4	+ 0,6	107,7	+ 0,6	1,0	87,0	37,0	34,5	37,0	33,5	36,0

- a Only applicable if a shoulder exists.
- b Actual length of socket  $L_{s1} \geq L_s$ .
- c Heated socket length  $L_{s2} \geq L_{s3} + 1,0$  mm.  
Minimum heated socket length  $L_{s2,min} = L_s - 2,5$  mm.  
Maximum heated socket length  $L_{s2,max} = L_s$ .
- d Minimum penetration of pipe into socket  $L_{s3,min} = L_s - 3,5$  mm.  
Maximum penetration of pipe into socket  $L_{s3,max} = L_s - 1,0$  mm.
- e Heated length of pipe  $L_{s4} \geq L_{s3}$ .
- f Tolerances rounded up to the nearest 0,1 mm.

Table B.7 — Diameters and lengths of sockets of type B socket fusion fittings

Dimensions in millimetres

Nominal outside diameter of pipe $d_n$	Mean outside diameter of pipe $d_{em}$		Mean inside diameter				Out-of-roundness max.	Bore $d_{s3}^a$	Reference socket length $L_s^b$	Heated socket length		Penetration of pipe into socket	
			Socket mouth $d_{s1m}$		Socket root $d_{s2m}$					$L_{s2}^c$	$L_{s3}^{d,e}$		
			min.	max.	min.	f						min.	max.
16	15,8	16,0	15,2	+ 0,3	15,1	+ 0,3	0,4	11,0	13,0	10,5	13,0	9,5	12,0
20	19,8	20,0	19,2	+ 0,3	19,0	+ 0,3	0,4	13,0	14,5	12,0	14,5	11,0	13,5
25	24,8	25,0	24,2	+ 0,3	23,9	+ 0,4	0,4	18,0	16,0	13,5	16,0	12,5	15,0
32	31,8	32,0	31,1	+ 0,4	30,9	+ 0,4	0,5	25,0	18,0	15,5	18,0	14,5	17,0
40	39,8	40,0	39,0	+ 0,4	38,8	+ 0,4	0,5	31,0	20,5	18,0	20,5	17,0	19,5
50	49,8	50,0	48,9	+ 0,5	48,7	+ 0,5	0,6	39,0	23,5	21,0	23,5	20,0	22,5
63	62,7	63,0	61,9	+ 0,6	61,6	+ 0,5	0,6	49,0	27,5	25,0	27,5	24,0	26,5
75	74,7	75,0	73,7	+ 0,5	73,4	+ 0,5	1,0	59,0	31,0	28,5	31,0	27,5	30,0
90	89,7	90,0	88,6	+ 0,6	88,2	+ 0,6	1,0	71,0	35,5	33,0	35,5	32,0	34,5
110	109,6	110,0	108,4	+ 0,6	108,0	+ 0,6	1,0	87,0	41,5	39,0	41,5	38,0	40,5

- a Only applicable if a shoulder exists.
- b Actual length of socket  $L_{s1} \geq L_s$ .
- c Heated socket length  $L_{s2} \geq L_{s3} + 1,0$  mm.  
Minimum heated socket length  $L_{s2,min} = L_s - 2,5$  mm.  
Maximum heated socket length  $L_{s2,max} = L_s$ .
- d Minimum penetration of pipe into socket  $L_{s3,min} = L_s - 3,5$  mm.  
Maximum penetration of pipe into socket  $L_{s3,max} = L_s - 1,0$  mm.
- e Heated length of pipe  $L_{s4} \geq L_{s3}$ .
- f Tolerances rounded up to the nearest 0,1 mm.

**B.3.2.3.3 Other dimensions**

Other dimensions of socket fusion fittings shall be as specified by the manufacturer.

**B.3.2.4 Electrofusion fittings**

**B.3.2.4.1 Dimensions of sockets of electrofusion fittings**

The dimensions of electrofusion fitting sockets (see Figure B.6) shall be as specified in Table B.8.

In the cases of fittings having sockets of different sizes (e.g. reduction fittings), each socket shall conform to the requirements for the nominal diameter of that socket.

In the cases of spigot end fittings, the outside length of the tubular part of the fusion-jointing end shall allow assembly with an electrofusion fitting.

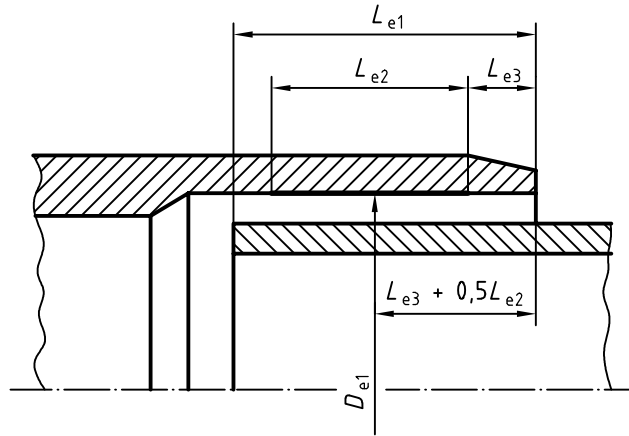

### Key

- $D_{e1}$  inside diameter in fusion zone measured in a plane parallel to the plane of the mouth at a distance  $L_{e3} + 0,5L_{e2}$  from that plane
- $L_{e1}$  depth of penetration of pipe or male end of a spigot fitting (in the case of a socket without a stop, this distance shall be not greater than half the total length of the fitting)
- $L_{e2}$  heated length of socket, i.e. the nominal length of the fusion zone as declared by the manufacturer
- $L_{e3}$  distance between mouth of socket and start of fusion zone, i.e. the nominal unheated length at the mouth of the socket as declared by the manufacturer ( $L_{e3}$  shall be  $\geq 5$  mm)

**Figure B.6 — Dimensions of sockets of electrofusion fittings**

Table B.8 — Dimensions of sockets of electrofusion fittings

Dimensions in millimetres

Nominal diameter of fitting $d_n$	Depth of penetration $L_{e1}$		Length of fusion zone $L_{e2}$
	min.	max.	min.
16	20	41	10
20	20	41	10
25	20	41	10
32	20	44	10
40	20	49	10
50	20	55	10
63	23	63	11
75	25	70	12
90	28	79	13
110	32	82	15
125	35	87	16
140	38	92	18
160	42	98	20
180	46	105	21
200	50	112	23
225	55	120	26
250	73	129	30
315	89	150	39
355	99	164	42
400	110	179	47
450	122	195	51
500	135	212	56
560	147	235	61
630	161	255	67

The manufacturer shall declare the actual maximum and minimum values of  $D_{e1}$  (see Figure B.6) and  $L_{e1}$  to determine the suitability of the fitting for clamping and joint assembly.

#### B.3.2.4.2 Dimensions of electrofusion saddle fittings

The manufacturer shall specify the overall dimensions of electrofusion saddle fittings (see Figure B.7) in the technical-data file. These dimensions shall include the maximum height of the saddle,  $H_e$ , and for tapping tees the height of the service pipe,  $h_e$ .

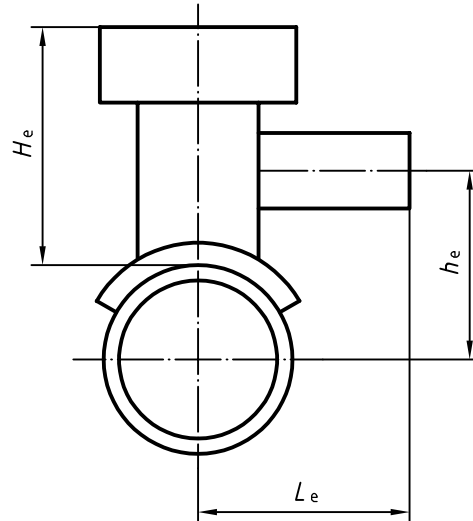

#### Key

- $H_e$  height of saddle, i.e. the distance from the top of the main pipe to the top of the tapping tee or saddle
- $h_e$  height of service pipe, i.e. the distance from the axis of the main pipe to the axis of the service pipe
- $L_e$  width of tapping tee, i.e. the distance between the axis of the main pipe and the plane of the mouth of the service tee

**Figure B.7 — Dimensions of electrofusion saddle fittings**

#### B.3.2.4.3 Other dimensions

Other dimensions of electrofusion fittings shall be as specified by the manufacturer.

**B.3.2.5 Flange adaptors and loose backing flanges**

**B.3.2.5.1 Dimensions of flange adaptors for butt fusion**

The dimensions of flange adaptors for butt fusion (see Figure B.8) shall be as specified in Table B.9.

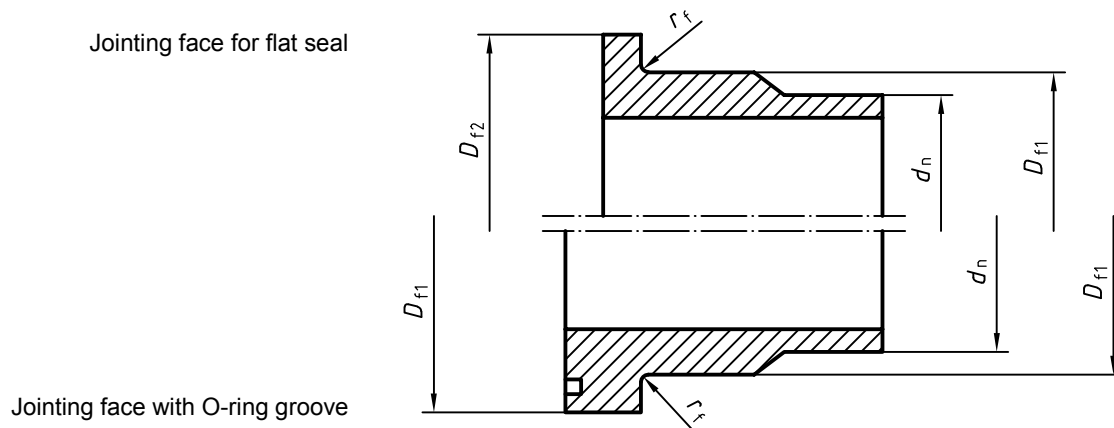

**Figure B.8 — Dimensions of flange adaptors for butt fusion**



Table B.9 — Dimensions of flange adaptors for butt fusion

Dimensions in millimetres

Nominal outside diameter of corresponding pipe	Outside diameter of chamfer on shoulder	Outside diameter of flange adaptor	Radius of chamfer on shoulder
$d_n$	$D_{f1}$	$D_{f2}$	$r_f$
16	22	40	3
20	27	45	3
25	33	58	3
32	40	68	3
40	50	78	3
50	61	88	3
63	75	102	4
75	89	122	4
90	105	138	4
110	125	158	4
125	132	158	4
140	155	188	4
160	175	212	4
180	183	212	4
200	232	268	4
225	235	268	4
250	285	320	4
280	291	320	4
315	335	370	4
355	373	430	6
400	427	482	6
450	514	585	6
500	530	585	6
560	615	685	6
630	642	685	6
710	737	800	8
800	840	905	8
900	944	1 005	8
1 000	1 047	1 110	8
1 200	1 245	1 330	8
1 400	1 450	1 540	8
1 600	1 650	1 760	10

**B.3.2.5.2 Dimensions of loose backing flanges for use with flange adaptors for butt fusion**

The dimensions of loose backing flanges for use with flange adaptors for butt fusion (see Figure B.9) shall be as specified in Table B.10.

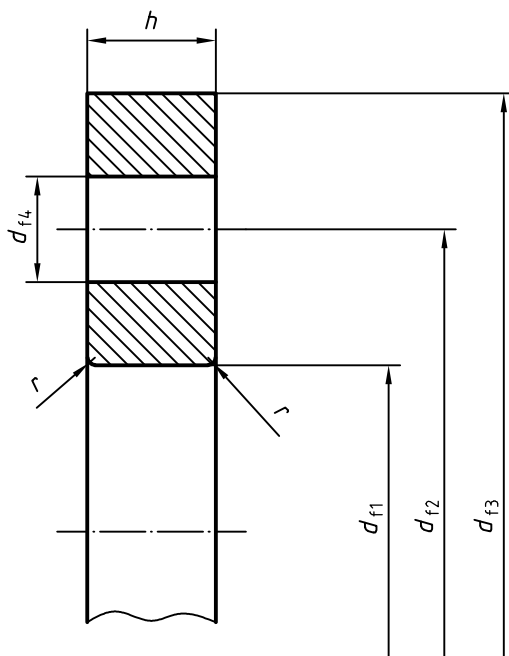

NOTE The thickness,  $h$ , of the loose backing flange is dependent on the material used.

**Figure B.9 — Dimensions of loose backing flanges for use with flange adaptors for butt fusion**

Table B.10 — Dimensions of loose backing flanges for use with flange adaptors for butt fusion

Dimensions in millimetres

Nominal outside diameter of corresponding pipe $d_n$	Nominal size of flange DN	Inside diameter of flange $d_{f1}$	Pitch circle diameter of bolt holes $d_{f2}$	Outside diameter of flange $d_{f3}$ min.	Diameter of bolt holes $d_{f4}$	Radius of flange $r$	Number of bolt holes	Metric thread of bolt
16	10	23	60	90	14	3	4	M12
20	15	28	65	95	14	3	4	M12
25	20	34	75	105	14	3	4	M12
32	25	42	85	115	14	3	4	M12
40	32	51	100	140	18	3	4	M16
50	40	62	110	150	18	3	4	M16
63	50	78	125	165	18	3	4	M16
75	65	92	145	185	18	3	4	M16
90	80	108	160	200	18	3	8	M16
110	100	128	180	220	18	3	8	M16
125	100	135	180	220	18	3	8	M16
140	125	158	210	250	18	3	8	M16
160	150	178	240	285	22	3	8	M20
180	150	188	240	285	22	3	8	M20
200	200	235	295	340	22	3	8	M20
225	200	238	295	340	22	3	8	M20
250	250	288	350	395	22	3	12	M20
280	250	294	350	395	22	3	12	M20
315	300	338	400	445	22	3	12	M20
355	350	376	460	505	22	4	16	M20
400	400	430	515	565	26	4	16	M24
450	500	517	620	670	26	4	20	M24
500	500	533	620	670	26	4	20	M24
560	600	618	725	780	30	4	20	M27
630	600	645	725	780	30	4	20	M27
710	700	740	840	895	30	5	24	M27
800	800	843	950	1 015	33	5	24	M30
900	900	947	1 050	1 115	33	5	28	M30
1 000	1 000	1 050	1 160	1 230	36	5	28	M33
1 200	1 200	1 260	1 380	1 455	39	6	32	M36
1 400	1 400	1 470	1 590	1 675	42	7	36	M39
1 600	1 600	1 670	1 820	1 915	48	7	40	M45

**B.3.2.5.3 Dimensions of flange adaptors for socket fusion**

The dimensions of flange adaptors for socket fusion (see Figure B.10) shall be as specified in Table B.11.

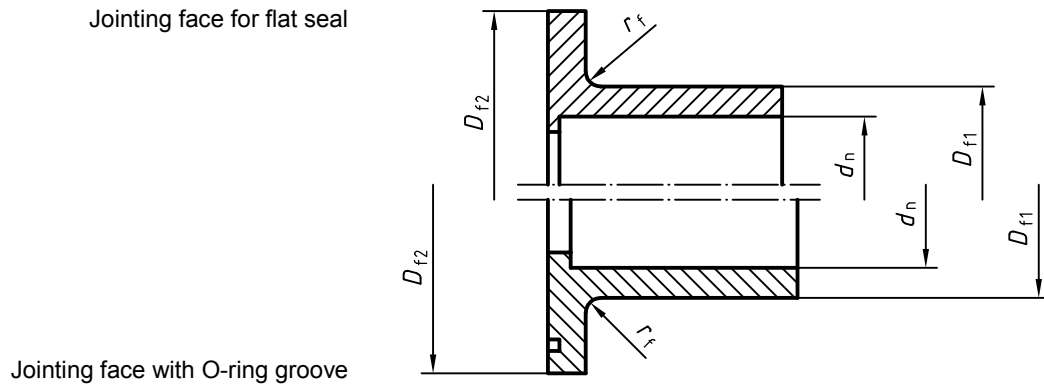

**Figure B.10 — Dimensions of flange adaptors for socket fusion**

**Table B.11 — Dimensions of flange adaptors for socket fusion**

Dimensions in millimetres

Nominal outside diameter of corresponding pipe $d_n$	Outside diameter of chamfer on shoulder $D_{f1}$	Outside diameter of flange adaptor $D_{f2}$	Radius of chamfer on shoulder $r_f$
16	22	40	3
20	27	45	3
25	33	58	3
32	41	68	3
40	50	78	3
50	61	88	3
63	76	102	4
75	90	122	4
90	108	138	4
110	131	158	4

**B.3.2.5.4 Dimensions of loose backing flanges for use with flange adaptors for socket fusion**

The dimensions of loose backing flanges for use with flange adaptors for socket fusion (see Figure B.11) shall be as specified in Table B.12.

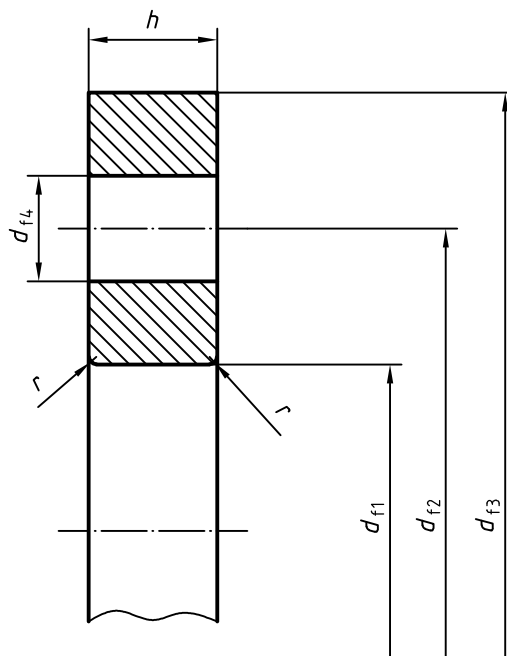

NOTE The thickness,  $h$ , of the loose backing flange is dependent on the material used.

**Figure B.11 — Dimensions of loose backing flanges for use with flange adaptors for socket fusion**

**Table B.12 — Dimensions of loose backing flanges for use with flange adaptors for socket fusion**

Dimensions in millimetres

Nominal outside diameter of corresponding pipe $d_n$	Nominal size of flange DN	Inside diameter of flange $d_{f1}$	Pitch circle diameter of bolt holes $d_{f2}$	Outside diameter of flange $d_{f3}$ min.	Diameter of bolt holes $d_{f4}$	Radius of flange $r$	Number of bolt holes	Metric thread of bolt
16	10	23	60	90	14	3	4	M12
20	15	28	65	95	14	3	4	M12
25	20	34	75	105	14	3	4	M12
32	25	42	85	115	14	3	4	M12
40	32	51	100	140	18	3	4	M16
50	40	62	110	150	18	3	4	M16
63	50	78	125	165	18	3	4	M16
75	65	92	145	185	18	3	4	M16
90	80	110	160	200	18	3	8	M16
110	100	133	180	220	18	3	8	M16

**B.4 Mechanical characteristics**

**B.4.1 Mechanical characteristics of pipes and fittings**

When tested as specified in Table B.13 under the test conditions indicated, using the test set-up indicated in Table B.14, components shall withstand the hydrostatic stress without bursting or leakage.

NOTE The internal pressure to be used is calculated as indicated in 8.2.

**Table B.13 — Requirements for internal-pressure testing**

Characteristic	Requirement	Test conditions			Test method <sup>a</sup>
		Material	Hydrostatic (hoop) stress MPa	Time h	
Resistance to internal pressure at 20 °C	No failure during test period	PE 63	8,0	≥ 100	ISO 1167 ISO 12092
		PE 80	10,0		
		PE 100	12,4		
Resistance to internal pressure at 80 °C	No failure during test period	PE 63	3,5	≥ 165 <sup>b</sup>	ISO 1167 ISO 12092
		PE 80	4,5		
		PE 100	5,4		
Resistance to internal pressure at 80 °C	No failure during test period	PE 63	3,2	≥ 1 000	ISO 1167 ISO 12092
		PE 80	4,0		
		PE 100	5,0		

<sup>a</sup> Fittings shall be prepared in accordance with ISO 12092 and tested in accordance with ISO 1167.

<sup>b</sup> Only brittle failure shall be taken into account. If a ductile failure occurs before the required minimum time, a lower stress shall be selected and the minimum test time taken from the stress/time points given in Table B.15.

**Table B.14 — Test set-up**

End caps	Type A as specified in ISO 1167:1996
Orientation	Not specified
Conditioning period	≥ 1 h
Type of test	Water-in-water or water-in-air <sup>a</sup>
<sup>a</sup> In cases of dispute, water-in-water shall be used.	

**Table B.15 — Hydrostatic (hoop) stress at 80 °C — Stress/time requirements in the case of ductile failure**

PE 63		PE 80		PE 100	
Stress	Minimum test period	Stress	Minimum test period	Stress	Minimum test period
MPa	h	MPa	h	MPa	h
3,5	165	4,5	165	5,4	165
3,4	295	4,4	233	5,3	256
3,3	538	4,3	331	5,2	399
3,2	1 000	4,2	474	5,1	629
—	—	4,1	685	5,0	1 000
—	—	4,0	1 000	—	—

**B.4.2 Mechanical characteristics of valves**

Valves shall conform to the requirements of ISO 16135, ISO 16136, ISO 16137, ISO 16138, ISO 16139 or ISO 21787, as applicable, depending on the valve type.

## B.5 Physical characteristics

### B.5.1 Physical characteristics of pipes

When determined in accordance with the test methods specified in Table B.16, using the parameters indicated, the physical characteristics of pipes shall conform to the requirements given in Table B.16.

**Table B.16 — Physical characteristics of pipes**

Characteristic	Requirement	Test parameters		Test method
Melt mass-flow rate (MFR)	When processing the material into a pipe, the MFR-value specified by the raw-material producer may deviate by, at the most, $\pm 20\%$ from the value for the raw material	Temperature Load	190 °C 5 kg	ISO 1133
Longitudinal reversion <sup>a</sup>	$\leq 3\%$  The pipe shall exhibit no bubbles or cracks	Temperature Immersion time: $e \leq 8$ mm $8 \text{ mm} < e \leq 16$ mm $e > 16$ mm Length of test piece	110 °C  30 min 60 min 120 min 200 mm	ISO 2505-1:1994 together with ISO 2505-2:1994  Method A: Liquid bath
		or		
		Temperature Immersion time: $e \leq 8$ mm $8 \text{ mm} < e \leq 16$ mm $e > 16$ mm Length of test piece	110 °C  60 min 120 min 240 min 200 mm	ISO 2505-1:1994 together with ISO 2505-2:1994  Method B: Air
<sup>a</sup> The choice between method A and method B is free. In cases of dispute, however, method A shall be used.				

### B.5.2 Physical characteristics of fittings

When determined in accordance with the test methods specified in Table B.17, using the parameters indicated, the physical characteristics of fittings shall conform to the requirements given in Table B.17.

**Table B.17 — Physical characteristics of fittings**

Characteristic	Requirement	Test parameters		Test method
Melt mass-flow rate (MFR)	When processing the material into a pipe, the MFR-value specified by the raw-material producer may deviate by, at the most, $\pm 20\%$ from the value for the raw material	Temperature Load	190 °C 5 kg	ISO 1133

### B.5.3 Physical characteristics of valves

In addition to the requirements of ISO 16135, ISO 16136, ISO 16137, ISO 16138, ISO 16139 or ISO 21787, as applicable, depending on the valve type, valves shall conform to the requirements of B.5.2.

## B.6 Fitness for purpose of the system

The fitness for purpose of the system shall be deemed to apply when test assemblies, assembled in accordance with 12.2 and tested using the test methods and parameters specified in Table B.18, conform to the requirements given in Table B.18.

**Table B.18 — General requirements for fitness for purpose of the system**

Characteristic	Requirement	Test parameters		Test method <sup>a</sup>
Hydrostatic strength at 80 °C For fusion joints	No failure during test period	End caps Orientation Test temperature Type of test Hydrostatic (hoop) stress: PE 63 PE 80 PE 100 Conditioning period Test period	Type A as specified in ISO 1167:1996 Not specified 80 °C Water-in-water 3,2 MPa 4,0 MPa 5,0 MPa ≥ 1 h ≥ 1 000 h	ISO 1167 and ISO 12092
Hydrostatic strength at 80 °C For mechanical joints	No failure during test period	End caps Orientation Test temperature Type of test Hydrostatic (hoop) stress: PE 63 PE 80 PE 100 Conditioning period Test period	Type A as specified in ISO 1167:1996 Not specified 80 °C Water-in-water 1,32 MPa 1,65 MPa 2,06 MPa ≥ 1 h ≥ 1 000 h	ISO 1167 and ISO 12092

<sup>a</sup> Assemblies of pipes and fittings shall be prepared in accordance with ISO 12092 and tested in accordance with ISO 1167.



## Annex C (normative)

### Specific characteristics and requirements for industrial piping systems made from polypropylene (PP)

#### C.1 Material

##### C.1.1 General

This annex is applicable to the following types of polypropylene:

- polypropylene homopolymer (PP-H);
- polypropylene block-copolymer (PP-B);
- polypropylene random-copolymer (PP-R).

##### C.1.2 Material for components

The material shall be tested in accordance with 5.2 at 20 °C, 60 °C to 82 °C and 95 °C as well as at various hydrostatic (hoop) stresses in such a way that, at each temperature, at least three failure times fall in each of the following time intervals:

- 10 h to 100 h;
- 100 h to 1 000 h;
- 1 000 h to 8 760 h;
- > 8 760 h.

In tests lasting more than 8 760 h, any time reached which corresponds to a point on or above the relevant reference curve may be considered as a failure time.

The values of the minimum required hydrostatic strength [see reference curves given in Figure C.1 (PP-H), Figure C.2 (PP-B) and Figure C.3 (PP-R)] in the temperature range of 10 °C to 95 °C were calculated using equations (C.1) to (C.6). The dotted sections of the curves for 80 °C, 90 °C, 95 °C and 110 °C represent the extrapolation of the curves, applicable when longer failure times are obtained at these temperatures.

NOTE 1 The reference curve for 110 °C was determined separately by testing using water-in-air and was not derived from equations (C.1) to (C.6).

First branch (i.e. the left-hand part of each curve shown in Figures C.1, C.2 and C.3):

$$\text{PP-H: } \log t = -46,364 - 9\,601,1 \times \frac{\log \sigma}{T} + 20\,381,5 \times \frac{1}{T} + 15,24 \times \log \sigma \quad (\text{C.1})$$

$$\text{PP-B: } \log t = -56,086 - 10\,157,8 \times \frac{\log \sigma}{T} + 23\,971,7 \times \frac{1}{T} + 13,32 \times \log \sigma \quad (\text{C.2})$$

$$\text{PP-R: } \log t = -55,725 - 9\,484,1 \times \frac{\log \sigma}{T} + 25\,502,2 \times \frac{1}{T} + 6,39 \times \log \sigma \quad (\text{C.3})$$

Second branch (i.e. the right-hand part of each curve shown in Figures C.1, C.2 and C.3):

$$\text{PP-H: } \log t = -18,387 + 8\,918,5 \times \frac{1}{T} - 4,1 \times \log \sigma \quad (\text{C.4})$$

$$\text{PP-B: } \log t = -13,699 + 6\,970,3 \times \frac{1}{T} - 3,82 \times \log \sigma \quad (\text{C.5})$$

$$\text{PP-R: } \log t = -19,98 + 9\,507,0 \times \frac{1}{T} - 4,11 \times \log \sigma \quad (\text{C.6})$$

NOTE 2 The calculation is given in more detail in ISO 3213.

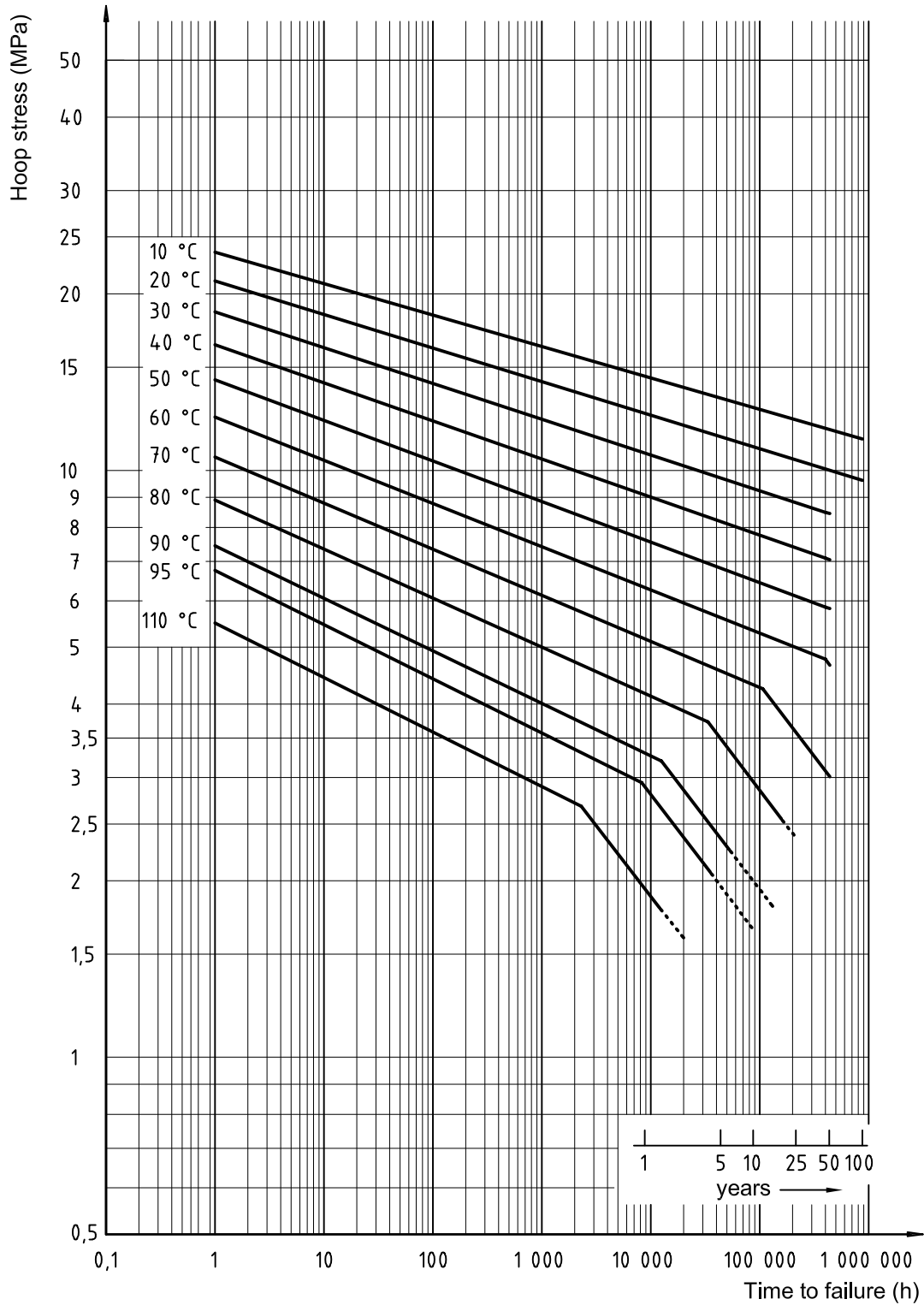

Figure C.1 — Minimum required hydrostatic strength curves for PP-H

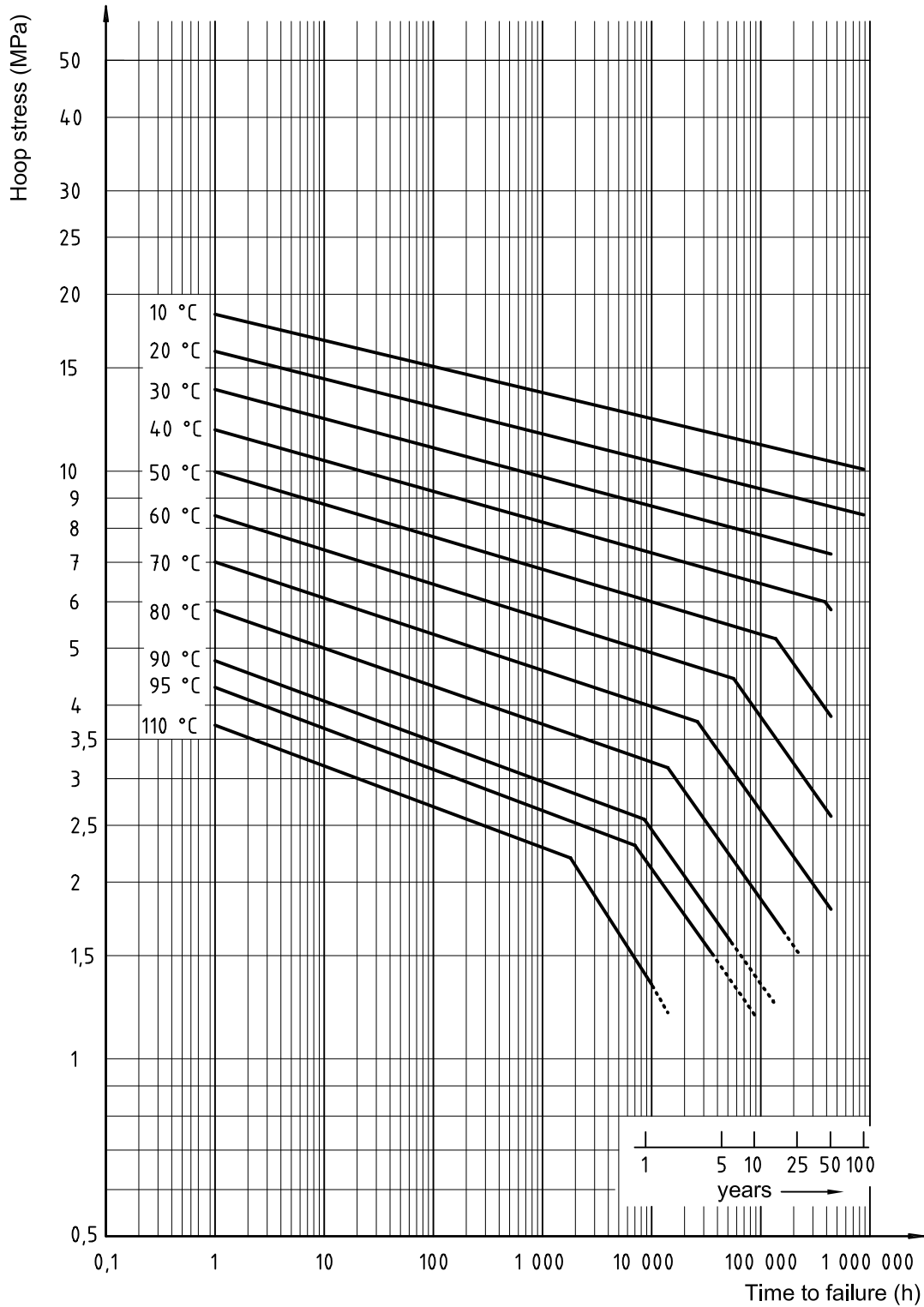

Figure C.2 — Minimum required hydrostatic strength curves for PP-B

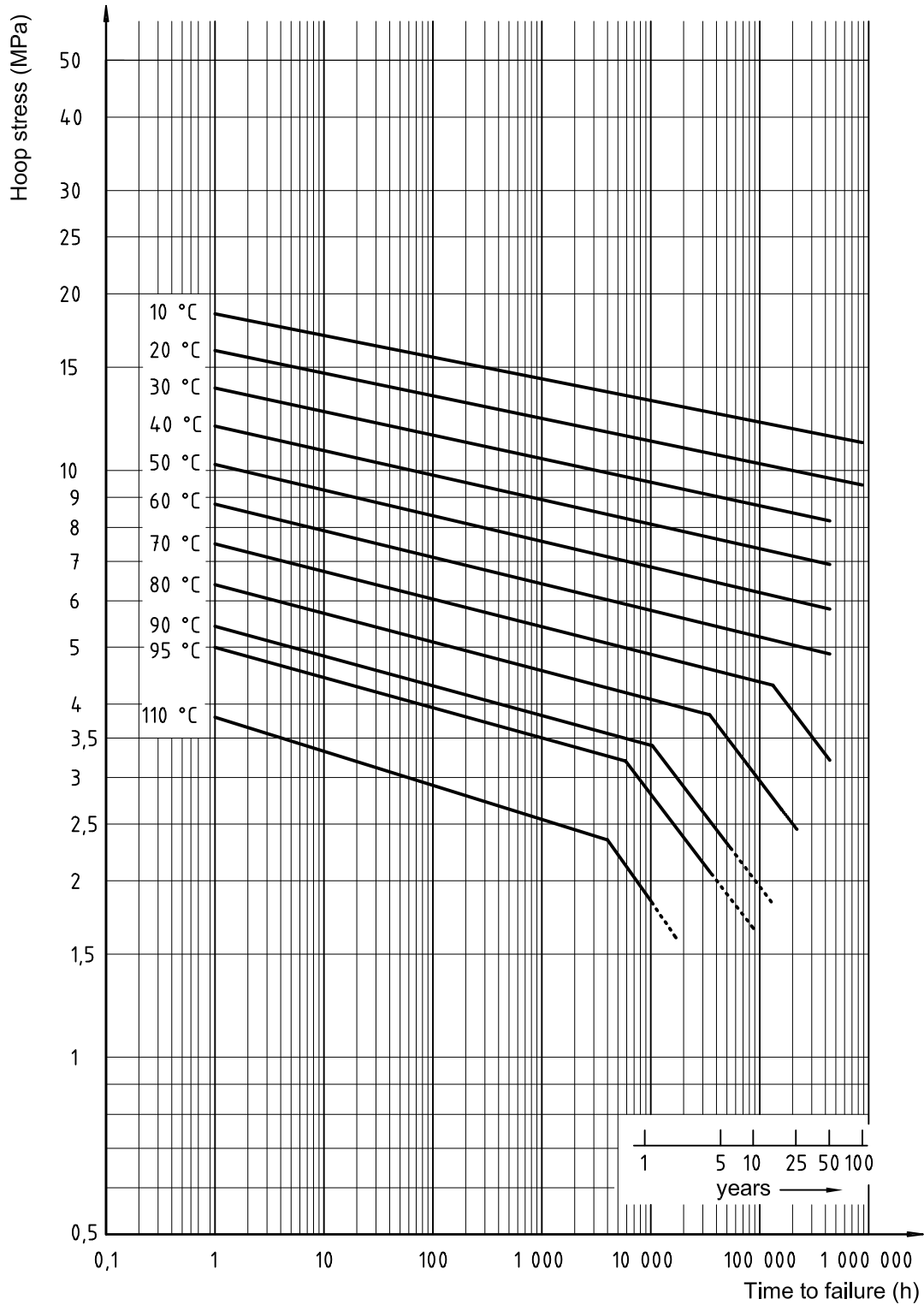

Figure C.3 — Minimum required hydrostatic strength curves for PP-R

**C.1.3 MRS-value**

When evaluated in accordance with 5.2, PP material shall have an MRS as given in Table C.1.

**Table C.1 — MRS-values of different types of PP**

PP type	MRS-value MPa
PP-H	≥ 10,0
PP-B	≥ 8,0
PP-R	≥ 8,0

**C.1.4 Other characteristics of material**

The material from which the components are manufactured shall conform to the requirements given in Table C.2.

**Table C.2 — Material characteristics of PP**

Characteristic	Requirement <sup>a</sup>	Test parameters			Test method
Pigment dispersion	≤ Grade 3	Preparation of test pieces	Compression or microtome procedure <sup>b</sup>		ISO 13949
Charpy impact strength	PP-H ≥ 7 kJ/m <sup>2</sup> PP-B ≥ 25 kJ/m <sup>2</sup> PP-R ≥ 25 kJ/m <sup>2</sup>	Test temperature Test piece	23 °C Notched		ISO 179-2:1997  Method: ISO 179-2/1eA
Melt mass-flow rate (MFR)	(0,18 ≤ MFR ≤ 0,4) g/10 min	Temperature Load	230 °C 2,16 kg		ISO 1133
Thermal stability assessed by determining resistance to internal pressure at 110 °C <sup>c,d</sup>	No failure during test period	Material	Hydrostatic (hoop) stress MPa	Time h	ISO 1167
		PP-H PP-B PP-R	1,9 1,4 1,9	≥ 8 760	

<sup>a</sup> Conformity to these requirements shall be declared by the raw-material producer.  
<sup>b</sup> In cases of dispute, the compression procedure shall be used.  
<sup>c</sup> Carried out as a type test only. The results from assessment in accordance with ISO 9080 shall be taken into account.  
<sup>d</sup> The test set-up is given in Table C.14.

**C.2 General characteristics — Colour**

Components made from PP should preferably be grey (RAL 7032<sup>4</sup>). Other colours shall be agreed on between manufacturer and purchaser.

NOTE To produce grey components, titanium dioxide (TiO<sub>2</sub>) (rutile type) is recommended.

4) RAL colour cards are obtainable from national standards institutes.

## C.3 Geometrical characteristics

### C.3.1 Dimensions of pipes

#### C.3.1.1 Diameters and associated tolerances

The mean outside diameter,  $d_{em}$ , determined as the average value of measurements made at distances of  $d_n$  and  $0,1d_n$  from the end of the test piece, shall be as specified in Table C.3.

NOTE Pipes with Grade A tolerances are used for socket fusion and electrofusion joints where the peeling technique is used to prepare the pipe end for fusion jointing. Pipes with Grade B tolerances are used for socket fusion joints where the peeling technique is not used.

#### C.3.1.2 Out-of-roundness

The out-of-roundness of straight lengths, measured at the point of manufacture, shall be as specified in Table C.3. If values for the out-of-roundness other than those given in Table C.3 are necessary, they shall be agreed on between manufacturer and purchaser.

For coiled pipes, the maximum out-of-roundness shall be specified by agreement between manufacturer and purchaser.

Table C.3 — Mean outside diameters, associated tolerances and out-of-roundness of pipes

Dimensions in millimetres

Nominal outside diameter $d_n$	Mean outside diameter $d_{em}$ min.	Tolerance on outside diameter		Out-of-roundness (straight pipes)
		Grade A <sup>a</sup>	Grade B <sup>a</sup>	Grade N <sup>a</sup> max.
12	12,0	+ 0,3	+ 0,3	1,2
16	16,0	+ 0,3	+ 0,3	1,2
20	20,0	+ 0,3	+ 0,3	1,2
25	25,0	+ 0,3	+ 0,3	1,2
32	32,0	+ 0,3	+ 0,3	1,3
40	40,0	+ 0,4	+ 0,4 <sup>b</sup>	1,4
50	50,0	+ 0,5	+ 0,4 <sup>b</sup>	1,4
63	63,0	+ 0,6	+ 0,4	1,5
75	75,0	+ 0,7	+ 0,5	1,6
90	90,0	+ 0,9	+ 0,6	1,8
110	110,0	+ 1,0	+ 0,7	2,2
125	125,0	+ 1,2	+ 0,8	2,5
140	140,0	+ 1,3	—	2,8
160	160,0	+ 1,5	—	3,2
180	180,0	+ 1,7	—	3,6
200	200,0	+ 1,8	—	4,0
225	225,0	+ 2,1	—	4,5
250	250,0	+ 2,3	—	5,0
280	280,0	+ 2,6	—	9,8
315	315,0	+ 2,9	—	11,1
355	355,0	+ 3,2	—	12,5
400	400,0	+ 3,6	—	14,0
450	450,0	+ 4,1	—	15,8 <sup>b</sup>
500	500,0	+ 4,5	—	17,5
560	560,0	+ 5,1	—	19,6
630	630,0	+ 5,7	—	22,1
710	710,0	+ 6,4	—	24,9
800	800,0	+ 7,2	—	28,0
900	900,0	+ 8,1	—	31,5
1 000	1 000,0	+ 9,0	—	35,0
1 200	1 200,0	+ 10,0	—	42,0
1 400	1 400,0	+ 10,0	—	49,0
1 600	1 600,0	+ 10,0	—	56,0

<sup>a</sup> In accordance with ISO 11922-1:1997.

<sup>b</sup> Not in accordance with ISO 11922-1:1997.



**C.3.1.3 Wall thicknesses and associated tolerances**

The wall thickness, *e*, and the associated tolerance shall be as specified in Table C.4.

**Table C.4 — Wall thicknesses and associated tolerances**

Dimensions in millimetres

Nominal outside diameter <i>d<sub>n</sub></i>	Wall thickness, <i>e</i> , and associated tolerance <sup>a</sup>															
	Pipe series S and standard dimension ratio SDR															
	S 20 SDR 41		S 16 SDR 33		S 12,5 SDR 26		S 8,3 SDR 17,6		S 8 SDR 17		S 5 SDR 11		S 3,2 SDR 7,4		S 2,5 SDR 6	
	<i>e</i> min.	<i>b</i>	<i>e</i> min.	<i>b</i>	<i>e</i> min.	<i>b</i>	<i>e</i> min.	<i>b</i>	<i>e</i> min.	<i>b</i>	<i>e</i> min.	<i>b</i>	<i>e</i> min.	<i>b</i>	<i>e</i> min.	<i>b</i>
12	—	—	—	—	—	—	—	—	—	—	1,8	+0,4	1,8	+0,4	2,0	+0,4
16	—	—	—	—	—	—	—	—	—	—	1,8	+0,4	2,2	+0,5	2,7	+0,5
20	—	—	—	—	—	—	1,8	+0,4	1,8	+0,4	1,9	+0,4	2,8	+0,5	3,4	+0,6
25	—	—	—	—	—	—	1,8	+0,4	1,8	+0,4	2,3	+0,5	3,5	+0,6	4,2	+0,7
32	—	—	—	—	—	—	1,9	+0,4	1,9	+0,4	2,9	+0,5	4,4	+0,7	5,4	+0,8
40	—	—	—	—	1,8	+0,4	2,3	+0,5	2,4	+0,5	3,7	+0,6	5,5	+0,8	6,7	+0,9
50	1,8	+0,4	1,8	+0,4	2,0	+0,4	2,9	+0,5	3,0	+0,5	4,6	+0,7	6,9	+0,9	8,3	+1,1
63	1,8	+0,4	2,0	+0,4	2,5	+0,5	3,6	+0,6	3,8	+0,6	5,8	+0,8	8,6	+1,1	10,5	+1,3
75	1,9	+0,4	2,3	+0,5	2,9	+0,5	4,3	+0,7	4,5	+0,7	6,8	+0,9	10,3	+1,3	12,5	+1,5
90	2,2	+0,5	2,8	+0,5	3,5	+0,6	5,1	+0,8	5,4	+0,8	8,2	+1,1	12,3	+1,5	15,0	+1,7
110	2,7	+0,5	3,4	+0,6	4,2	+0,7	6,3	+0,9	6,6	+0,9	10,0	+1,2	15,1	+1,8	18,3	+2,1
125	3,1	+0,6	3,9	+0,6	4,8	+0,7	7,1	+1,0	7,4	+1,0	11,4	+1,4	17,1	+2,0	20,8	+2,3
140	3,5	+0,6	4,3	+0,7	5,4	+0,8	8,0	+1,0	8,3	+1,1	12,7	+1,5	19,2	+2,2	23,3	+2,6
160	4,0	+0,6	4,9	+0,7	6,2	+0,9	9,1	+1,2	9,5	+1,2	14,6	+1,7	21,9	+2,4	26,6	+2,9
180	4,4	+0,7	5,5	+0,8	6,9	+0,9	10,2	+1,3	10,7	+1,3	16,4	+1,9	24,6	+2,7	29,9	+3,2
200	4,9	+0,7	6,2	+0,9	7,7	+1,0	11,4	+1,4	11,9	+1,4	18,2	+2,1	27,4	+3,0	33,2	+3,6
225	5,5	+0,8	6,9	+0,9	8,6	+1,1	12,8	+1,5	13,4	+1,6	20,5	+2,3	30,8	+3,3	37,4	+4,0
250	6,2	+0,9	7,7	+1,0	9,6	+1,2	14,2	+1,7	14,8	+1,7	22,7	+2,5	34,2	+3,7	—	—
280	6,9	+0,9	8,6	+1,1	10,7	+1,3	15,9	+1,8	16,6	+1,9	25,4	+2,8	38,3	+4,1	—	—
315	7,7	+1,0	9,7	+1,2	12,1	+1,5	17,9	+2,0	18,7	+2,1	28,6	+3,1	43,1	+4,6	—	—
355	8,7	+1,1	10,9	+1,3	13,6	+1,6	20,1	+2,3	21,1	+2,4	32,2	+3,5	48,5	+5,1	—	—
400	9,8	+1,2	12,3	+1,5	15,3	+1,8	22,7	+2,5	23,7	+2,6	36,3	+3,9	54,7	+5,7	—	—
450	11,0	+1,3	13,8	+1,6	17,2	+2,0	25,5	+2,8	26,7	+2,9	40,9	+4,3	—	—	—	—
500	12,3	+1,5	15,3	+1,8	19,2	+2,2	28,3	+3,1	29,7	+3,2	45,4	+4,8	—	—	—	—
560	13,7	+1,6	17,2	+2,0	21,4	+2,4	31,7	+3,4	33,2	+3,6	50,8	+5,3	—	—	—	—
630	15,4	+1,8	19,3	+2,2	24,1	+2,7	35,7	+3,8	37,4	+4,0	—	—	—	—	—	—
710	17,4	+2,0	21,8	+2,4	27,2	+3,0	40,2	+4,3	42,1	+4,5	—	—	—	—	—	—
800	19,6	+2,2	24,5	+2,7	30,6	+3,3	45,3	+4,8	47,4	+5,0	—	—	—	—	—	—
900	22,0	+2,4	27,6	+3,0	34,4	+3,7	51,0	+5,3	—	—	—	—	—	—	—	—
1 000	24,5	+2,7	30,6	+3,3	38,2	+4,1	—	—	—	—	—	—	—	—	—	—
1 200	29,4	+3,2	36,7	+3,9	45,9	+4,8	—	—	—	—	—	—	—	—	—	—
1 400	34,3	+3,7	42,9	+4,5	53,5	+5,6	—	—	—	—	—	—	—	—	—	—
1 600	39,2	+4,2	49,0	+5,1	61,2	+6,4	—	—	—	—	—	—	—	—	—	—

<sup>a</sup> All dimensions correspond to those given in ISO 4065.

<sup>b</sup> The tolerances have been calculated from the expression (0,1*e* + 0,2) mm and rounded up to the nearest 0,1 mm.

## C.3.2 Dimensions of fittings

### C.3.2.1 General

This annex is applicable to the following types of fittings:

- butt fusion fittings;
- socket fusion fittings;
- electrofusion fittings;
- flange adaptors and loose backing flanges;
- mechanical fittings.

### C.3.2.2 Butt fusion fittings

#### C.3.2.2.1 Lengths and diameters of spigot ends of butt fusion fittings

The minimum inside and outside lengths,  $L_{b1}$  and  $L_{b2}$ , of spigot ends (see Figure C.4) shall be as specified in Table C.5. The mean outside diameter,  $d_{em}$ , of the spigot end over the length  $L_{b2}$  shall be as specified in C.3.1.1, except between the plane of the mouth and a plane parallel to it, at a distance not more than  $(0,01d_n + 1)$  mm, where a reduction in the outside diameter is permissible.

#### C.3.2.2.2 Out-of-roundness

The out-of-roundness of spigot ends over the length  $L_{b2}$  (see Figure C.4 and Table C.5) shall be as specified in C.3.1.2.

#### C.3.2.2.3 Wall thicknesses of spigot ends

The wall thickness,  $e$ , of spigot ends over the length  $L_{b1}$  (see Figure C.4 and Table C.5) shall be as specified in C.3.1.3, except between the plane of the mouth and a plane parallel to it, at a distance not more than  $(0,01d_n + 1)$  mm, where a reduction in the outside diameter is permissible, e.g. for a chamfered edge.

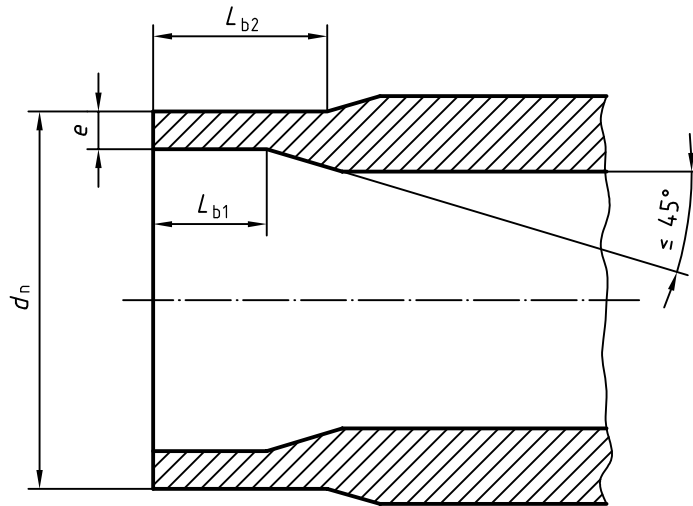
**Key**

- $L_{b1}$  inside length of spigot end  
 $L_{b2}$  outside length of spigot end

**Figure C.4 — Dimensions of spigot ends of butt fusion fittings**

**Table C.5 — Dimensions of spigot ends of butt fusion fittings**

Dimensions in millimetres

Nominal outside diameter $d_n$	Inside length of spigot end $L_{b1}^a$ min.	Outside length of spigot end $L_{b2}^a$ min.
12	4	10
16	4	10
20	4	10
25	4	10
32	5	10
40	5	10
50	5	12
63	6	12
75	6	12
90	7	12
110	8	12
125	8	15
140	9	15
160	9	20
180	10	20
200	11	20
225	12	25
250	13	25
280	14	30
315	15	30
355	16	30
400	18	30
450	20	35
500	20	35
560	20	40
630	20	40
710	20	40
800	20	50
900	20	50
1 000	20	60
1 200	20	60
1 400	20	70
1 600	20	70

<sup>a</sup> For bends, a reduction in the length(s) of the tubular part(s) of the spigot end is permissible.

NOTE The minimum lengths given in this table are too short for electrofusion joints. For electrofusion jointing, a length corresponding to the depth of penetration specified in Table C.8 is necessary.

**C.3.2.2.4 Wall thickness of fitting body**

The wall thickness,  $e$ , of the fitting body shall be at least equal to the minimum wall thickness of the corresponding pipe (see C.3.1.3).

**C.3.2.2.5 Other dimensions**

Other dimensions of butt fusion fittings shall be as specified by the manufacturer.

### C.3.2.3 Socket fusion fittings

#### C.3.2.3.1 Types of socket fusion fitting

Socket fusion fittings (see Figure C.5) shall be classified as one of two types, as follows:

- **Type A:** Fittings intended to be used with pipes having dimensions as given in C.3.1 where no machining of the outside surface of the pipe is required.
- **Type B:** Fittings intended to be used with pipes having dimensions as given in C.3.1 where machining of the outside surface of the pipe is necessary in accordance with the manufacturer's instructions.

#### C.3.2.3.2 Diameters and lengths of sockets

The nominal outside diameter(s),  $d_n$ , of a socket fusion fitting shall correspond to, and be designated by, the nominal outside diameter(s) of the pipe(s) for which it is designed.

The diameters and lengths of sockets of type A socket fusion fittings shall be as specified in Table C.6. For type B socket fusion fittings, the socket diameters and lengths shall be as specified in Table C.7.

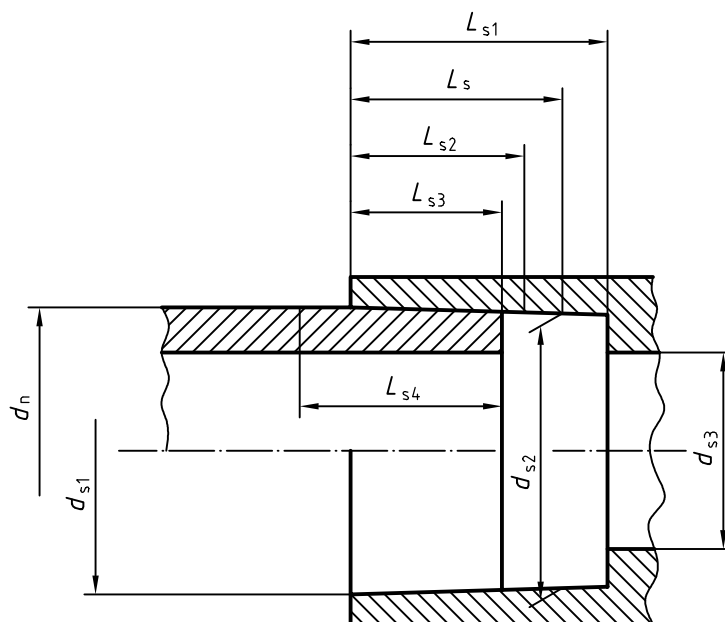

#### Key

- $d_n$  nominal outside diameter
- $d_{s1}$  inside diameter of socket mouth
- $d_{s2}$  inside diameter of socket root, i.e. the inside diameter of a circular plane parallel to the plane of the socket mouth and located a distance  $L_s$  (the reference socket length) from the socket mouth
- $d_{s3}$  minimum diameter of flow channel (bore) through body of fitting
- $L_s$  reference socket length, i.e. the theoretical minimum socket length used for calculation purposes
- $L_{s1}$  actual length of socket, i.e. the distance from the socket mouth to the shoulder, if any
- $L_{s2}$  heated length of socket, i.e. the depth of penetration of the heated tool into the socket
- $L_{s3}$  insertion length, i.e. the depth of penetration of the pipe into the socket
- $L_{s4}$  heated length of pipe, i.e. the depth of penetration of the pipe into the heated tool

**Figure C.5 — Diameters and lengths of socket fusion fittings**

Table C.6 — Diameters and lengths of sockets of type A socket fusion fittings

Dimensions in millimetres

Nominal outside diameter of pipe $d_n$	Mean outside diameter of pipe $d_{em}$ min.	Mean inside diameter				Out-of-roundness max.	Bore $d_{s3}$ <sup>a</sup> min.	Reference socket length $L_s$ <sup>b</sup> min.	Heated socket length		Penetration of pipe into socket	
		Socket mouth $d_{s1m}$		Socket root $d_{s2m}$					min.	max.	min.	max.
		min.	f	min.	f							
16	16,0	15,2	+ 0,3	15,1	+ 0,3	0,4	11,0	13,0	10,5	13,0	9,5	12,0
20	20,0	19,2	+ 0,3	19,0	+ 0,3	0,4	13,0	14,5	12,0	14,5	11,0	13,5
25	25,0	24,2	+ 0,3	23,9	+ 0,4	0,4	18,0	16,0	13,5	16,0	12,5	15,0
32	32,0	31,1	+ 0,4	30,9	+ 0,4	0,5	25,0	18,0	15,5	18,0	14,5	17,0
40	40,0	39,0	+ 0,4	38,8	+ 0,4	0,5	31,0	20,5	18,0	20,5	17,0	19,5
50	50,0	48,9	+ 0,5	48,7	+ 0,5	0,6	39,0	23,5	21,0	23,5	20,0	22,5
63	63,0	61,9	+ 0,6	61,6	+ 0,5	0,6	49,0	27,5	25,0	27,5	24,0	26,5
75	75,0	74,3	+ 0,6	73,1	+ 0,6	1,0	59,0	30,0	27,5	30,0	26,5	29,0
90	90,0	89,3	+ 0,6	87,9	+ 0,6	1,0	71,0	33,0	31,5	33,0	30,5	32,0
110	110,0	109,4	+ 0,6	107,7	+ 0,6	1,0	87,0	37,0	34,5	37,0	33,5	36,0

- a Only applicable if a shoulder exists.
- b Actual length of socket  $L_{s1} \geq L_s$ .
- c Heated socket length  $L_{s2} \geq L_{s3} + 1,0$  mm.  
Minimum heated socket length  $L_{s2,min} = L_s - 2,5$  mm.  
Maximum heated socket length  $L_{s2,max} = L_s$ .
- d Minimum penetration of pipe into socket  $L_{s3,min} = L_s - 3,5$  mm.  
Maximum penetration of pipe into socket  $L_{s3,max} = L_s - 1,0$  mm.
- e Heated length of pipe  $L_{s4} \geq L_{s3}$ .
- f Tolerances rounded up to the nearest 0,1 mm.

Table C.7 — Diameters and lengths of sockets of type B socket fusion fittings

Dimensions in millimetres

Nominal outside diameter of pipe $d_n$	Mean outside diameter of pipe $d_{em}$		Mean inside diameter				Out-of-roundness max.	Bore $d_{s3}^a$	Reference socket length $L_s^b$	Heated socket length $L_{s2}^c$		Penetration of pipe into socket $L_{s3}^{d,e}$	
			Socket mouth $d_{s1m}$		Socket root $d_{s2m}$								
			min.	max.	min.	f							
16	15,8	16,0	15,2	+ 0,3	15,1	+ 0,3	0,4	11,0	13,0	10,5	13,0	9,5	12,0
20	19,8	20,0	19,2	+ 0,3	19,0	+ 0,3	0,4	13,0	14,5	12,0	14,5	11,0	13,5
25	24,8	25,0	24,2	+ 0,3	23,9	+ 0,4	0,4	18,0	16,0	13,5	16,0	12,5	15,0
32	31,8	32,0	31,1	+ 0,4	30,9	+ 0,4	0,5	25,0	18,0	15,5	18,0	14,5	17,0
40	39,8	40,0	39,0	+ 0,4	38,8	+ 0,4	0,5	31,0	20,5	18,0	20,5	17,0	19,5
50	49,8	50,0	48,9	+ 0,5	48,7	+ 0,5	0,6	39,0	23,5	21,0	23,5	20,0	22,5
63	62,7	63,0	61,9	+ 0,6	61,6	+ 0,5	0,6	49,0	27,5	25,0	27,5	24,0	26,5
75	74,7	75,0	73,7	+ 0,5	73,4	+ 0,5	1,0	59,0	31,0	28,5	31,0	27,5	30,0
90	89,7	90,0	88,6	+ 0,6	88,2	+ 0,6	1,0	71,0	35,5	33,0	35,5	32,0	34,5
110	109,6	110,0	108,4	+ 0,6	108,0	+ 0,6	1,0	87,0	41,5	39,0	41,5	38,0	40,5

<sup>a</sup> Only applicable if a shoulder exists.

<sup>b</sup> Actual length of socket  $L_{s1} \geq L_s$ .

<sup>c</sup> Heated socket length  $L_{s2} \geq L_{s3} + 1,0$  mm.  
Minimum heated socket length  $L_{s2,min} = L_s - 2,5$  mm.

Maximum heated socket length  $L_{s2,max} = L_s$ .

<sup>d</sup> Minimum penetration of pipe into socket  $L_{s3,min} = L_s - 3,5$  mm.  
Maximum penetration of pipe into socket  $L_{s3,max} = L_s - 1,0$  mm.

<sup>e</sup> Heated length of pipe  $L_{s4} \geq L_{s3}$ .

<sup>f</sup> Tolerances rounded up to the nearest 0,1 mm.

### C.3.2.3.3 Other dimensions

Other dimensions of socket fusion fittings shall be as specified by the manufacturer.

### C.3.2.4 Electrofusion fittings

#### C.3.2.4.1 Dimensions of sockets of electrofusion fittings

The dimensions of electrofusion fitting sockets (see Figure C.6) shall be as specified in Table C.8.

In the cases of fittings having sockets of different sizes (e.g. reduction fittings), each socket shall conform to the requirements for the nominal diameter of that socket.

In the cases of spigot end fittings, the outside length of the tubular part of the fusion-jointing end shall allow assembly with an electrofusion fitting.

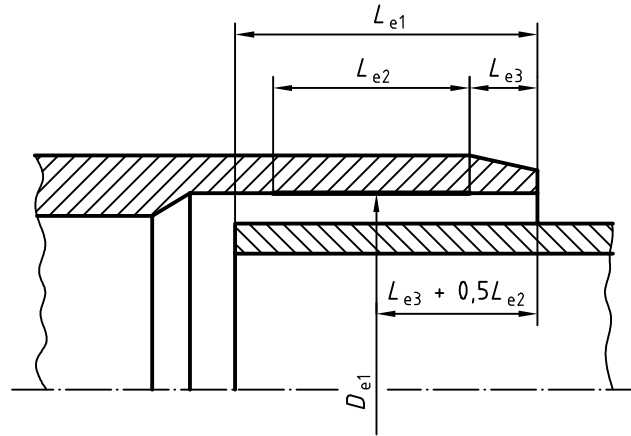

- Key**
- $D_{e1}$  inside diameter in fusion zone measured in a plane parallel to the plane of the mouth at a distance  $L_{e3} + 0,5L_{e2}$  from that plane
  - $L_{e1}$  depth of penetration of pipe or male end of a spigot fitting (in the case of a socket without a stop, this distance shall be not greater than half the total length of the fitting)
  - $L_{e2}$  heated length of socket, i.e. the nominal length of the fusion zone as declared by the manufacturer
  - $L_{e3}$  distance between mouth of socket and start of fusion zone, i.e. the nominal unheated length at the mouth of the socket as declared by the manufacturer ( $L_{e3}$  shall be  $\geq 5$  mm)

**Figure C.6 — Dimensions of sockets of electrofusion fittings**



Table C.8 — Dimensions of sockets of electrofusion fittings

Dimensions in millimetres

Nominal diameter of fitting $d_n$	Depth of penetration		Length of fusion zone
	min.	$L_{e1}$ max.	$L_{e2}$ min.
16	20	41	10
20	20	41	10
25	20	41	10
32	20	44	10
40	20	49	10
50	20	55	10
63	23	63	11
75	25	70	12
90	28	79	13
110	32	82	15
125	35	87	16
140	38	92	18
160	42	98	20
180	46	105	21
200	50	112	23
225	55	120	26
250	73	129	30
315	89	150	39
355	99	164	42
400	110	179	47
450	122	195	51
500	135	212	56
560	147	235	61
630	161	255	67

The manufacturer shall declare the actual maximum and minimum values of  $D_{e1}$  (see Figure C.6) and  $L_{e1}$  to determine the suitability of the fitting for clamping and joint assembly.

**C.3.2.4.2 Dimensions of electrofusion saddle fittings**

The manufacturer shall specify the overall dimensions of electrofusion saddle fittings (see Figure C.7) in the technical-data file. These dimensions shall include the maximum height of the saddle,  $H_e$ , and for tapping tees the height of the service pipe,  $h_e$ .

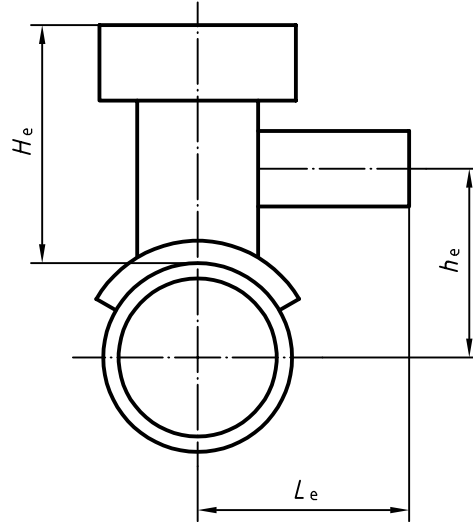

**Key**

- $H_e$  height of saddle, i.e. the distance from the top of the main pipe to the top of the tapping tee or saddle
- $h_e$  height of service pipe, i.e. the distance from the axis of the main pipe to the axis of the service pipe
- $L_e$  width of tapping tee, i.e. the distance between the axis of the main pipe and the plane of the mouth of the service tee

**Figure C.7 — Dimensions of electrofusion saddle fittings**

**C.3.2.4.3 Other dimensions**

Other dimensions of electrofusion fittings shall be as specified by the manufacturer.

**C.3.2.5 Flange adaptors and loose backing flanges**

**C.3.2.5.1 Dimensions of flange adaptors for butt fusion**

The dimensions of flange adaptors for butt fusion (see Figure C.8) shall be as specified in Table C.9.

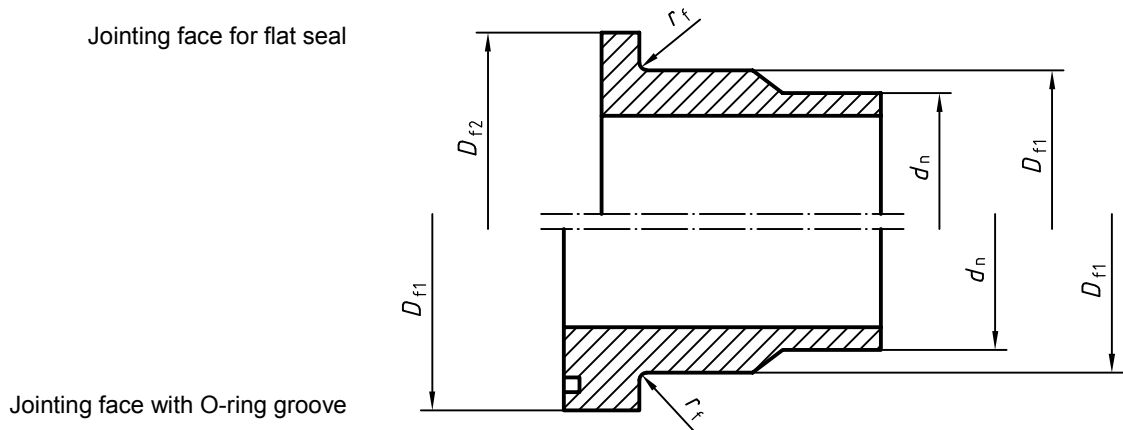

**Figure C.8 — Dimensions of flange adaptors for butt fusion**

Table C.9 — Dimensions of flange adaptors for butt fusion

Dimensions in millimetres

Nominal outside diameter of corresponding pipe	Outside diameter of chamfer on shoulder	Outside diameter of flange adaptor	Radius of chamfer on shoulder
$d_n$	$D_{f1}$	$D_{f2}$	$r_f$
16	22	40	3
20	27	45	3
25	33	58	3
32	40	68	3
40	50	78	3
50	61	88	3
63	75	102	4
75	89	122	4
90	105	138	4
110	125	158	4
125	132	158	4
140	155	188	4
160	175	212	4
180	183	212	4
200	232	268	4
225	235	268	4
250	285	320	4
280	291	320	4
315	335	370	4
355	373	430	6
400	427	482	6
450	514	585	6
500	530	585	6
560	615	685	6
630	642	685	6
710	737	800	8
800	840	905	8
900	944	1 005	8
1 000	1 047	1 110	8
1 200	1 245	1 330	8
1 400	1 450	1 540	8
1 600	1 650	1 760	10

### C.3.2.5.2 Dimensions of loose backing flanges for use with flange adaptors for butt fusion

The dimensions of loose backing flanges for use with flange adaptors for butt fusion (see Figure C.9) shall be as specified in Table C.10.

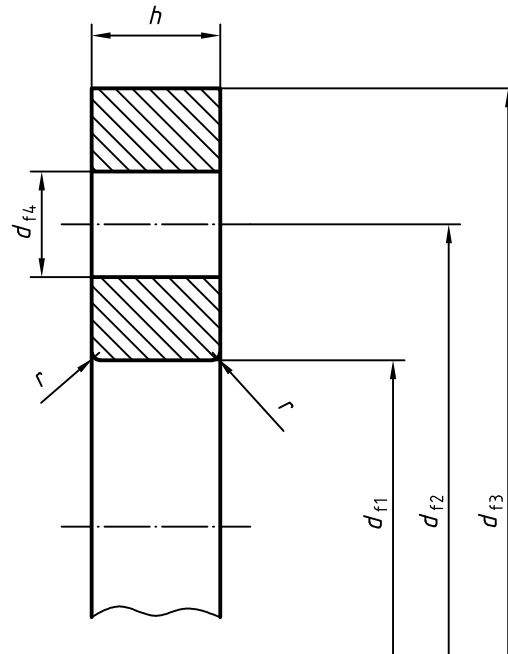

NOTE The thickness,  $h$ , of the loose backing flange is dependent on the material used.

**Figure C.9 — Dimensions of loose backing flanges for use with flange adaptors for butt fusion**

Table C.10 — Dimensions of loose backing flanges for use with flange adaptors for butt fusion

Dimensions in millimetres

Nominal outside diameter of corresponding pipe $d_n$	Nominal size of flange DN	Inside diameter of flange $d_{f1}$	Pitch circle diameter of bolt holes $d_{f2}$	Outside diameter of flange $d_{f3}$ min.	Diameter of bolt holes $d_{f4}$	Radius of flange $r$	Number of bolt holes	Metric thread of bolt
16	10	23	60	90	14	3	4	M12
20	15	28	65	95	14	3	4	M12
25	20	34	75	105	14	3	4	M12
32	25	42	85	115	14	3	4	M12
40	32	51	100	140	18	3	4	M16
50	40	62	110	150	18	3	4	M16
63	50	78	125	165	18	3	4	M16
75	65	92	145	185	18	3	4	M16
90	80	108	160	200	18	3	8	M16
110	100	128	180	220	18	3	8	M16
125	100	135	180	220	18	3	8	M16
140	125	158	210	250	18	3	8	M16
160	150	178	240	285	22	3	8	M20
180	150	188	240	285	22	3	8	M20
200	200	235	295	340	22	3	8	M20
225	200	238	295	340	22	3	8	M20
250	250	288	350	395	22	3	12	M20
280	250	294	350	395	22	3	12	M20
315	300	338	400	445	22	3	12	M20
355	350	376	460	505	22	4	16	M20
400	400	430	515	565	26	4	16	M24
450	500	517	620	670	26	4	20	M24
500	500	533	620	670	26	4	20	M24
560	600	618	725	780	30	4	20	M27
630	600	645	725	780	30	4	20	M27
710	700	740	840	895	30	5	24	M27
800	800	843	950	1 015	33	5	24	M30
900	900	947	1 050	1 115	33	5	28	M30
1 000	1 000	1 050	1 160	1 230	36	5	28	M33
1 200	1 200	1 260	1 380	1 455	39	6	32	M36
1 400	1 400	1 470	1 590	1 675	42	7	36	M39
1 600	1 600	1 670	1 820	1 915	48	7	40	M45

**C.3.2.5.3 Dimensions of flange adaptors for socket fusion**

The dimensions of flange adaptors for socket fusion (see Figure C.10) shall be as specified in Table C.11.

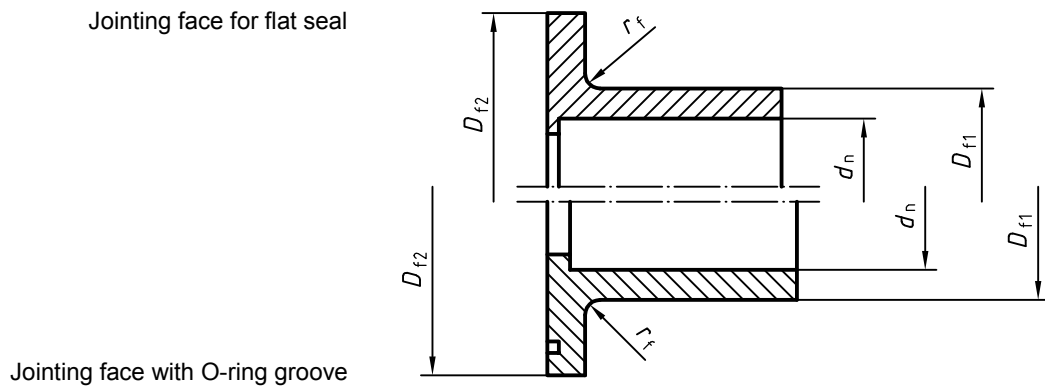

**Figure C.10 — Dimensions of flange adaptors for socket fusion**

**Table C.11 — Dimensions of flange adaptors for socket fusion**

Dimensions in millimetres

Nominal outside diameter of corresponding pipe $d_n$	Outside diameter of chamfer on shoulder $D_{f1}$	Outside diameter of flange adaptor $D_{f2}$	Radius of chamfer on shoulder $r_f$
16	22	40	3
20	27	45	3
25	33	58	3
32	41	68	3
40	50	78	3
50	61	88	3
63	76	102	4
75	90	122	4
90	108	138	4
110	131	158	4

**C.3.2.5.4 Dimensions of loose backing flanges for use with flange adaptors for socket fusion**

The dimensions of loose backing flanges for use with flange adaptors for socket fusion (see Figure C.11) shall be as specified in Table C.12.

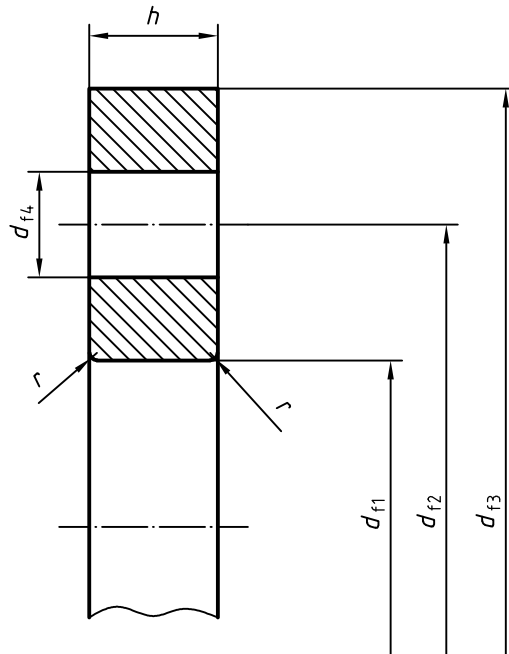

NOTE The thickness, *h*, of the loose backing flange is dependent on the material used.

**Figure C.11 — Dimensions of loose backing flanges for use with flange adaptors for socket fusion**

**Table C.12 — Dimensions of loose backing flanges for use with flange adaptors for socket fusion**

Dimensions in millimetres

Nominal outside diameter of corresponding pipe $d_n$	Nominal size of flange DN	Inside diameter of flange $d_{f1}$	Pitch circle diameter of bolt holes $d_{f2}$	Outside diameter of flange $d_{f3}$ min.	Diameter of bolt holes $d_{f4}$	Radius of flange $r$	Number of bolt holes	Metric thread of bolt
16	10	23	60	90	14	3	4	M12
20	15	28	65	95	14	3	4	M12
25	20	34	75	105	14	3	4	M12
32	25	42	85	115	14	3	4	M12
40	32	51	100	140	18	3	4	M16
50	40	62	110	150	18	3	4	M16
63	50	78	125	165	18	3	4	M16
75	65	92	145	185	18	3	4	M16
90	80	110	160	200	18	3	8	M16
110	100	133	180	220	18	3	8	M16



## C.4 Mechanical characteristics

### C.4.1 Mechanical characteristics of pipes and fittings

#### C.4.1.1 Resistance to internal pressure of pipes and fittings

When tested as specified in Table C.13 under the test conditions indicated, using the test set-up indicated in Table C.14, components shall withstand the hydrostatic stress without bursting or leakage.

NOTE The internal pressure to be used is calculated as indicated in 8.2.

**Table C.13 — Requirements for internal-pressure testing**

Characteristic	Requirement	Test conditions			Test method <sup>a</sup>
		Material	Hydrostatic (hoop) stress MPa	Time h	
Resistance to internal pressure at 20 °C	No failure during test period	PP-H	21,0	≥ 1	ISO 1167 ISO 12092
		PP-B	16,0		
		PP-R	16,0		
Resistance to internal pressure at 95 °C		PP-H	3,5	≥ 1 000	ISO 1167 ISO 12092
		PP-B	2,6		
		PP-R	3,5		

<sup>a</sup> Fittings shall be prepared in accordance with ISO 12092 and tested in accordance with ISO 1167.

**Table C.14 — Test set-up**

End caps	Type A as specified in ISO 1167:1996
Orientation	Not specified
Conditioning period	≥ 1 h
Type of test	Water-in-water or water-in-air <sup>a</sup>
<sup>a</sup> In cases of dispute, water-in-water shall be used.	

#### C.4.1.2 Resistance to impact of pipes

Prepare test pieces with the dimensions specified in Table C.15 by taking them from pipes. Depending on the nominal diameter of the pipe under evaluation, the test pieces shall be in the form of lengths of pipe (type 1) or longitudinally oriented bars (type 2 and type 3). Type 2 and type 3 bars shall be taken from pipe sections of length  $(50 \pm 1)$  mm and  $(120 \pm 2)$  mm respectively, at locations separated as equally as possible round the circumference. The width of the type 2 and type 3 test pieces given in Table C.15 corresponds to the length,  $b$ , of the chord between the inside edges of the test piece (see Figure C.12).

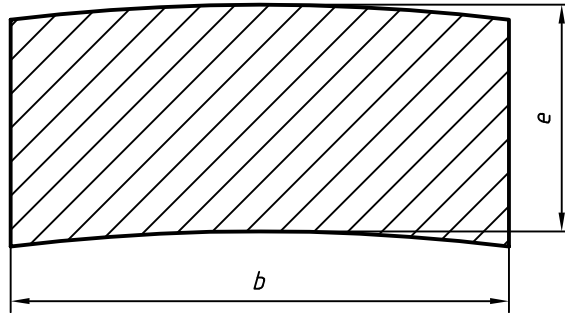

Figure C.12 — Shape of type 2 and type 3 test pieces for impact testing

Table C.15 — Requirements for impact testing

Dimensions in millimetres

Test piece type	Pipe		Test piece			Span
	Nominal outside diameter $d_n$	Wall thickness $e$	Length	Width $b$	Thickness	
1	< 25	$e$	Pipe section of length $100 \pm 2$			$70^{+0,5}_0$
2	$\geq 25$	$\leq 4,2$	$50 \pm 1$	$6 \pm 0,2$	$e$	$40^{+0,5}_0$
3	> 25	> 4,2	$120 \pm 2$	$15 \pm 0,5$	$\leq 10,5$	$70^{+0,5}_0$

If the pipe wall thickness is  $\leq 10,5$  mm, do not machine the surface of the test pieces. If the pipe wall thickness is  $> 10,5$  mm, machine the test pieces to a thickness of  $(10 \pm 0,5)$  mm. After machining, smooth the machined surface by sanding in the longitudinal direction with fine sandpaper. Carry out the impact test specified in ISO 179-2 on 10 test pieces at a temperature of  $(23 \pm 2)$  °C for PP-H pipes and  $(0 \pm 2)$  °C for PP-B and PP-R pipes, making the impact on the outside, or prepared, surface.

Inspect the test pieces for fractures. If more than one test piece fails, repeat the test with 20 new test pieces taken from the same pipe. In this case, assess the TIR of the first and the second set of tests together.

#### C.4.2 Mechanical characteristics of valves

Valves shall conform to the requirements of ISO 16135, ISO 16136, ISO 16137, ISO 16138, ISO 16139 or ISO 21787, as applicable, depending on the valve type.

## C.5 Physical characteristics

### C.5.1 Physical characteristics of pipes

When determined in accordance with the test methods specified in Table C.16, using the parameters indicated, the physical characteristics of pipes shall conform to the requirements given in Table C.16.

**Table C.16 — Physical characteristics of pipes**

Characteristic	Requirement	Test parameters		Test method
Melt mass-flow rate (MFR)	When processing the material into a pipe, the MFR-value specified by the raw-material producer may deviate by, at the most, $\pm 30\%$ from the value for the raw material	Temperature Load	230 °C 2,16 kg	ISO 1133
Longitudinal reversion <sup>a</sup>  For PP-H and PP-B	$\leq 2\%$  The pipe shall exhibit no bubbles or cracks	Temperature Immersion time: $e \leq 16$ mm $e > 16$ mm Length of test piece	150 °C  30 min 60 min 200 mm	ISO 2505-1:1994 together with ISO 2505-2:1994  Method A: Liquid bath
		or		
		Temperature Immersion time: $e \leq 16$ mm $e > 16$ mm Length of test piece	150 °C  60 min 120 min 200 mm	ISO 2505-1:1994 together with ISO 2505-2:1994  Method B: Air
Longitudinal reversion <sup>a</sup>  For PP-R	$\leq 2\%$  The pipe shall exhibit no bubbles or cracks	Temperature Immersion time: $e \leq 16$ mm $e > 16$ mm Length of test piece	135 °C  30 min 60 min 200 mm	ISO 2505-1:1994 together with ISO 2505-2:1994  Method A: Liquid bath
		or		
		Temperature Immersion time: $e \leq 16$ mm $e > 16$ mm Length of test piece	135 °C  60 min 120 min 200 mm	ISO 2505-1:1994 together with ISO 2505-2:1994  Method B: Air
<sup>a</sup> The choice between method A and method B is free. In cases of dispute, however, method A shall be used.				

### C.5.2 Physical characteristics of fittings

When determined in accordance with the test methods specified in Table C.17, using the parameters indicated, the physical characteristics of fittings shall conform to the requirements given in Table C.17.

**Table C.17 — Physical characteristics of fittings**

Characteristic	Requirement	Test parameters		Test method
Melt mass-flow rate (MFR)	When processing the material into a pipe, the MFR-value specified by the raw-material producer may deviate by, at the most, $\pm 30\%$ from the value for the raw material	Temperature Load	230 °C 2,16 kg	ISO 1133

### C.5.3 Physical characteristics of valves

In addition to the requirements of ISO 16135, ISO 16136, ISO 16137, ISO 16138, ISO 16139 or ISO 21787, as applicable, depending on the valve type, valves shall conform to the requirements of C.5.2.

## C.6 Fitness for purpose of the system

The fitness for purpose of the system shall be deemed to apply when test assemblies, assembled in accordance with 12.2 and tested using the test methods and parameters specified in Table C.18, conform to the requirements given in Table C.18.

**Table C.18 — General requirements for fitness for purpose of the system**

Characteristic	Requirement	Test parameters		Test method <sup>a</sup>
Hydrostatic strength at 20 °C For fusion joints	No failure during test period	End caps Orientation Test temperature Type of test Hydrostatic (hoop) stress: PP-H PP-B PP-R Conditioning period Test period	Type A as specified in ISO 1167:1996 Not specified 20 °C Water-in-water or water-in-air <sup>b</sup>  21,0 MPa 16,0 MPa 16,0 MPa ≥ 1 h ≥ 1 h	ISO 1167 and ISO 12092
Hydrostatic strength at 95 °C For fusion joints	No failure during test period	End caps Orientation Test temperature Type of test Hydrostatic (hoop) stress: PP-H PP-B PP-R Conditioning period Test period	Type A as specified in ISO 1167:1996 Not specified 95 °C Water-in-water or water-in-air <sup>b</sup>  3,5 MPa 2,6 MPa 3,5 MPa ≥ 1 h ≥ 1 000 h	ISO 1167 and ISO 12092
Hydrostatic strength at 20 °C For mechanical joints	No failure during test period	End caps Orientation Test temperature Type of test Hydrostatic (hoop) stress: PP-H PP-B PP-R Conditioning period Test period	Type A as specified in ISO 1167:1996 Not specified 20 °C Water-in-water or water-in-air <sup>b</sup>  10,8 MPa 7,5 MPa 7,6 MPa ≥ 1 h ≥ 1 000 h	ISO 1167 and ISO 12092
Hydrostatic strength at 95 °C For mechanical joints	No failure during test period	End caps Orientation Test temperature Type of test Hydrostatic (hoop) stress: PP-H PP-B PP-R Conditioning period Test period	Type A as specified in ISO 1167:1996 Not specified 95 °C Water-in-water or water-in-air <sup>b</sup>  1,85 MPa 1,45 MPa 1,60 MPa ≥ 1 h ≥ 1 000 h	ISO 1167 and ISO 12092
<sup>a</sup> Assemblies of pipes and fittings shall be prepared in accordance with ISO 12092 and tested in accordance with ISO 1167. <sup>b</sup> In cases of dispute, water-in-water shall be used.				

## Bibliography

- [1] ISO 3, *Preferred numbers — Series of preferred numbers*
- [2] ISO 497, *Guide to the choice of series of preferred numbers and of series containing more rounded values of preferred numbers*
- [3] ISO 1872-1, *Plastics — Polyethylene (PE) moulding and extrusion materials — Part 1: Designation system and basis for specifications*
- [4] ISO 1873-1, *Plastics — Polypropylene (PP) moulding and extrusion materials — Part 1: Designation system and basis for specifications*
- [5] ISO 4427, *Polyethylene (PE) pipes for water supply — Specifications*
- [6] ISO 4433 (all parts), *Thermoplastics pipes — Resistance to liquid chemicals — Classification*
- [7] ISO 8986-1, *Plastics — Polybutene (PB) moulding and extrusion materials — Part 1: Designation system and basis for specifications*
- [8] ISO 9001, *Quality management systems — Requirements*
- [9] ISO 9393 (all parts), *Thermoplastics valves — Pressure test methods and requirements*
- [10] ISO 10241, *International terminology standards — Preparation and layout*
- [11] ISO 10931 (all parts), *Plastics piping systems for industrial applications — Poly(vinylidene fluoride) (PVDF)*
- [12] ISO/TR 11647, *Fusion compatibility of polyethylene (PE) pipes and fittings*
- [13] ISO 15493, *Plastics piping systems for industrial applications — Acrylonitrile-butadiene-styrene (ABS), unplasticized poly(vinyl chloride) (PVC-U) and chlorinated poly(vinyl chloride) (PVC-C) — Specifications for components and the system — Metric series*
- [14] ISO/TR 16913, *Plastics pipes and fittings — Definitions of types of test*

## Correspondence between International and European Standards

Due to the intention to publish this International Standard as a European Standard, the following list is given of European Standards which correspond to the International Standards for the test methods used in this International Standard. Although it has no corresponding International Standard, EN 1778 is included for the sake of completeness. Attention is drawn to the fact that, for a particular test method, the technical content of the International Standard and the European Standard may be different. The listing is therefore given for information only and is not intended to indicate technical conformity between the documents.

ISO 1167:1996	EN 921, <i>Plastics piping systems — Thermoplastics pipes — Determination of resistance to internal pressure at constant temperature</i>
ISO 2505-1:1994 ISO 2505-2:1994	EN 743, <i>Plastics piping and ducting systems — Thermoplastics pipes — Determination of the longitudinal reversion</i>
ISO/TR 10837:1991	EN 728, <i>Plastics piping and ducting systems — Polyolefin pipes and fittings — Determination of oxidation induction time</i>

ISO 12092:2000

EN 12107, *Plastics piping systems — Injection-moulded thermoplastics fittings, valves and ancillary equipment — Determination of the long-term hydrostatic strength of thermoplastics materials for injection moulding of piping components*

EN 1778, *Characteristic values for welded thermoplastic constructions — Determination of allowable stresses and moduli for design of thermoplastics equipment*

---

---

**ICS 23.040.01**

Price based on 89 pages

© ISO 2003 – All rights reserved