

INTERNATIONAL STANDARD

ISO 15465

First edition
2004-03-15

Pipework — Stripwound metal hoses and hose assemblies

Tuyauteries — Tuyaux et tuyauteries métalliques flexibles agrafés



Reference number
ISO 15465:2004(E)

© ISO 2004

PDF disclaimer

This PDF file may contain embedded typefaces. In accordance with Adobe's licensing policy, this file may be printed or viewed but shall not be edited unless the typefaces which are embedded are licensed to and installed on the computer performing the editing. In downloading this file, parties accept therein the responsibility of not infringing Adobe's licensing policy. The ISO Central Secretariat accepts no liability in this area.

Adobe is a trademark of Adobe Systems Incorporated.

Details of the software products used to create this PDF file can be found in the General Info relative to the file; the PDF-creation parameters were optimized for printing. Every care has been taken to ensure that the file is suitable for use by ISO member bodies. In the unlikely event that a problem relating to it is found, please inform the Central Secretariat at the address given below.

© ISO 2004

All rights reserved. Unless otherwise specified, no part of this publication may be reproduced or utilized in any form or by any means, electronic or mechanical, including photocopying and microfilm, without permission in writing from either ISO at the address below or ISO's member body in the country of the requester.

ISO copyright office
Case postale 56 • CH-1211 Geneva 20
Tel. + 41 22 749 01 11
Fax + 41 22 749 09 47
E-mail copyright@iso.org
Web www.iso.org

Published in Switzerland

Contents

Page

Foreword	iv
Introduction	v
1 Scope	1
2 Normative references	1
3 Terms and definitions	1
4 Information to be supplied by the purchaser	1
5 Hose types	2
6 Requirements	3
6.1 Materials	3
6.2 Hose dimensions	4
6.3 Tensile strength	5
6.4 Crush strength	5
6.5 Temperature	6
6.6 Pressure (for type DOP hose only)	8
6.7 Assembly	8
7 Type tests	8
7.1 Tensile strength test	8
7.2 Crush strength test	9
7.3 Bend test	10
7.4 Pressure test (for type DOP hose)	11
8 Production tests — Pressure proof test (for type DOP hose)	11
9 Designation	11
10 Marking	12
Bibliography	13

Foreword

ISO (the International Organization for Standardization) is a worldwide federation of national standards bodies (ISO member bodies). The work of preparing International Standards is normally carried out through ISO technical committees. Each member body interested in a subject for which a technical committee has been established has the right to be represented on that committee. International organizations, governmental and non-governmental, in liaison with ISO, also take part in the work. ISO collaborates closely with the International Electrotechnical Commission (IEC) on all matters of electrotechnical standardization.

International Standards are drafted in accordance with the rules given in the ISO/IEC Directives, Part 2.

The main task of technical committees is to prepare International Standards. Draft International Standards adopted by the technical committees are circulated to the member bodies for voting. Publication as an International Standard requires approval by at least 75 % of the member bodies casting a vote.

Attention is drawn to the possibility that some of the elements of this document may be the subject of patent rights. ISO shall not be held responsible for identifying any or all such patent rights.

ISO 15465 was prepared by Technical Committee ISO/TC 5, *Ferrous metal pipes and metallic fittings*, Subcommittee SC 11, *Metal hoses and expansion joints*.

This first edition of ISO 15465 cancels and replaces ISO 7657:1995, ISO 7658:1984, ISO 8444:1985, ISO 8445:1995, ISO 8446:1995, ISO 8447:1986, ISO 8448:1986, ISO 8449:1995 and ISO 8450:1986 of which it constitutes a technical revision.

Introduction

It was decided to produce an International Standard under the Vienna Agreement, on technical cooperation between ISO and the European Committee for Standardization, CEN, in order to maintain one document. The opportunity was taken to replace all existing stripwound standards into this single document and to reformat it such that its layout is similar to the International Standard for corrugated hose, ISO 10380. At the same time, additional information has been included which was not available when the replaced standards were originally produced.

This document is a base standard for stripwound metal hoses and hose assemblies for general purposes.

Pipework — Stripwound metal hoses and hose assemblies

1 Scope

This International Standard specifies the requirements for the design, manufacture and testing of four principal types of stripwound metal hose and hose assemblies, of which only one type is for pressure applications. The four are: single overlap, unpacked and packed; double overlap, unpacked and packed, the last of these having maximum allowable pressures of up to 40 bar.

These hoses and hose assemblies may be supplied in nominal sizes from DN 6 to DN 500 and may operate at temperatures up to 600 °C dependent on materials of construction.

2 Normative references

The following referenced documents are indispensable for the application of this document. For dated references, only the edition cited applies. For undated references, the latest edition of the referenced document (including any amendments) applies.

ISO 554, *Standard atmospheres for conditioning and/or testing — Specifications*

ISO 1634-1, *Wrought copper and copper alloy plate, sheet and strip — Part 1: Technical conditions of delivery for plate, sheet and strip for general purposes*

ISO 2081, *Metallic coatings — Electroplated coatings of zinc on iron or steel*

ISO 6317, *Hot-rolled carbon steel strip of commercial and drawing qualities*

ISO 7369, *Pipework — Metal hoses and hose assemblies — Vocabulary*

ISO 9328-5, *Steel plates and strips for pressure purposes — Technical delivery conditions — Part 5: Austenitic steels*

ISO 10380, *Pipework — Corrugated metal hoses and hose assemblies*

EN 10028-7, *Flat products made of steels for pressure purposes — Part 7: Stainless steels*

3 Terms and definitions

For the purposes of this document, the terms and definitions given in ISO 7369 apply.

4 Information to be supplied by the purchaser

4.1 The purchaser shall state the following in enquiries and orders

- a) application;
- b) nominal size and hose assembly length and whether measured in mid- or extended position;

- c) hose type;
- d) maximum operating pressure;
- e) temperature range;
- f) materials;
- g) type of fitting.

4.2 Dependent on the application the purchaser shall provide the following information

- a) whether additional testing is required;
- b) service life;
- c) product to be conveyed;
- d) product velocity;
- e) any special information concerning choice of materials;
- f) movement and/or vibration;
- g) any additional requirements for cleaning and post test treatment;
- h) requirements for test certificates;
- i) if a coloured cover or other identification is required;
- j) any special requirements for packaging;
- k) requirements for user instructions.

5 Hose types

5.1 Type SOU: single overlap, unpacked — see Figure 1

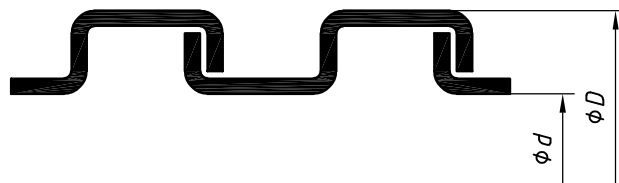

Figure 1 — Cross-section of a type SOU, single overlap, unpacked hose

5.2 Type SOP: single overlap, packed — see Figure 2

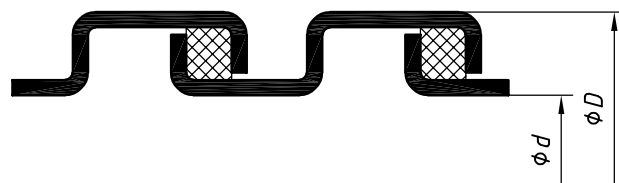

Figure 2 — Cross-section of a type SOP, single overlap, packed hose

5.3 Type DOU: double overlap, unpacked — see Figure 3



Figure 3 — Cross-Section of a type DOU, double overlap, unpacked hose

5.4 Type DOP: double overlap, packed — see Figure 4



Figure 4 — Cross-section of a type DOP, double overlap, packed hose

6 Requirements

6.1 Materials

6.1.1 General

The values of bend radii, and tensile and crush strengths for single overlap designs in protected carbon steel, together with those for double overlap designs in protected carbon steel and stainless steel, shall be in accordance with those given in Tables 1 to 3. If materials other than those given in 6.1.2 are used, the values of the parameters given in Tables 1 to 3 shall be agreed between the manufacturer and the user.

6.1.2 Metal strips

Strips for the manufacture of stripwound metal hose shall be selected on the basis of their suitability for fabrication e.g. cold forming, welding, etc. and for the conditions under which they will be used (see 4.1 and 4.2). Suitable materials are:

- carbon steel strip (C/S) conforming to ISO 6317, either plain or protected. If the protection is galvanizing it shall be either electro- or hot-dip. Other protections are permitted provided they meet the requirements of ISO 2081;
- austenitic or ferritic stainless steel strip (S/S) conforming to ISO 9328-5 or EN 10028-7;
- bronze or brass strip (B/S) conforming to ISO 1634-1.

6.1.3 Packing

Suitable packing materials for full or limited leak-tightness include cotton, glass fibre, polyamine, polyester either pure or in a mixture. Other suitable materials for limited leak-tightness include natural or synthetic rubber or copper.

Packings shall not contain asbestos.

6.2 Hose dimensions

6.2.1 Internal and external diameter

The minimum internal and maximum external diameter shall be as given in Table 1.

Table 1 — Hose bores, external diameters, bend radii and maximum allowable pressures

For all hose types			Test Bend radius							Maximum allowable pressure	
Nominal size (in accordance with ISO 6708)	Minimum internal diameter	Maximum external diameter	Single overlap			Double overlap				Double overlap	
			SOU Unpacked	SOP rubber-packed	SOP other-Packed	DOU unpacked	DOP copper-packed	DOP pressure-packed		DOP pressure-packed	
DN	<i>d</i>	<i>D</i>	C/S	C/S	C/S	C/S	C/S	C/S	S/S	C/S	S/S
	mm	mm	mm	mm	mm	mm	mm	mm	mm	bar	bar
6	5	8.3	30	55	55	70	—	—	—	—	—
8	7	10.3	35	65	65	80	—	—	—	—	—
10	9.5	13.5	40	75	85	90	—	—	—	—	—
12	11	17	45	85	95	105	165	165	165	32	40
15	13	21	50	100	110	130	180	185	185	30	32
20	18	26	65	135	150	150	205	210	205	25	32
25	23	32	75	155	175	175	235	240	235	21	32
32	31	39	90	190	210	205	275	290	290	18	32
40	37	49	115	210	240	250	320	340	350	15	31
50	48	59	135	240	270	305	370	410	420	13	26
65	62	76	170	290	330	365	460	540	550	11	20,5
80	75	89	200	325	390	400	570	650	670	9.5	17
100	97	111	265	395	475	485	700	820	840	8	14
125	120	136	325	530	570	625	860	1 050	1 050	7	12
150	144	163	370	585	640	805	1 040	1 250	1 250	6	10
200	192	216	495	780	890	1 000	1 360	1 600	1 650	5	8
250	245	266	620	975	1 140	1 200	1 700	2 000	2 050	4,4	6,5
300	295	317	755	1 165	1 330	1 450	2 000	2 400	2 450	3,8	5.5
350	327	367	—	1 360	1 525	1 525	2 350	2 800	2 850	3,4	5
400	378	418	—	1 550	1 715	1 770	2 650	3 200	3 200	3,1	4,5
450	428	468	—	1 750	1 970	1 990	2 950	3 600	3 600	2,9	4
500	478	520	—	1 940	2 210	2 210	3 250	4 000	4 000	2,7	3,6

NOTE 1 The relationship between the bend radius and coiling diameter of a hose is given in 7.3.

NOTE 2 C/S: carbon steel as defined in 6.1.2.a).

NOTE 3 S/S: stainless steel as defined in 6.1.2.b).

6.2.2 Length

The hose or hose assembly length shall be measured in either the mid-position and or in the extended position depending on the purchaser's requirements and shall be the length as ordered with a tolerance of ± 3 % unless otherwise stated.

6.2.3 Bend radius

The bend radius of the hose when measured in accordance with 6.3 shall be equal to or less than that shown in Table 1.

6.3 Tensile strength

When tested in accordance with 7.1, the value of tensile load shall be equal to or higher than that given in Table 2.

Table 2 — Hose tensile strengths

Nominal size (in accordance with ISO 6708)	Minimum tensile strength N						
	Single overlap			Double overlap			
	SOU unpacked	SOP rubber- packed	SOP other packed	DOU unpacked	DOP copper- packed	DOP pressure-packed	
DN	C/S	C/S	C/S	C/S	C/S	C/S	S/S
6	220	110	220	500	—	—	—
8	300	150	300	800	—	—	—
10	400	200	400	1100	—	—	—
12	500	250	500	1 400	900	900	4 500
15	600	300	600	1 700	1 500	1 500	5 000
20	800	400	800	2 300	2 300	2 300	5 800
25	1 000	500	1 000	2 800	3 200	3 200	7 500
32	1 300	650	1 300	3 500	4 400	4 400	10 000
40	1 600	800	1 600	4 000	6 000	6 000	13 000
50	2 000	1 000	2 000	5 000	8 000	8 000	17 000
65	2 500	1 300	2 600	6 000	12 000	12 000	23 000
80	3 400	1 700	3 400	7 500	16 000	16 000	29 000
100	4 200	2 200	4 200	9 000	21 000	21 000	38 000
125	5 200	2 700	5 400	11 000	28 000	28 000	49 000
150	6 500	3 250	6 500	14 000	36 000	36 000	60 000
200	A	4 500	9 000	18 000	36 000	36 000	60 000
250	A	5 500	11 000	22 000	36 000	36 000	60 000
300	A	6 600	13 000	25 000	36 000	36 000	60 000
350	—	8 000	16 000	28 000	36 000	36 000	60 000
400	—	9 000	18 000	31 000	36 000	36 000	60 000
450	—	10 000	20 000	34 000	36 000	36 000	60 000
500	—	11 500	23 000	37 000	36 000	36 000	60 000

NOTE 1 C/S: carbon steel as defined in 6.1.2.a).
NOTE 2 S/S: stainless steel as defined in 6.1.2.b).
NOTE 3 A: refer to manufacturer.

6.4 Crush strength

When tested in accordance with 7.2, the crush strength shall be equal to or greater than the value given in Table 3.

Table 3 — Hose crush strengths

Nominal size (in accordance with ISO 6708)	Minimum crush strength N						
	Single overlap			Double overlap			
	SOU unpacked	SOP rubber-packed	SOP other packed	DOU unpacked	DOP copper-packed	DOP pressure-packed	
DN	C/S	C/S	C/S	C/S	C/S	C/S	S/S
6	4 000	3 000	3 500	4 500	—	—	—
8	4 000	3 000	3 500	3 000	—	—	—
10	4 000	3 000	3 500	2 600	—	—	—
12	4 000	3 000	3 500	2 200	10 000	8 000	11 000
15	4 000	3 000	3 500	1 800	9 400	7 500	11 000
20	4 000	3 000	3 500	2 600	9 000	7 200	10 500
25	4 000	3 000	3 500	1 600	8 700	6 900	10 000
32	4 000	3 000	3 500	1 200	8 300	6 600	9 700
40	4 000	3 000	3 500	1 800	8 100	6 400	9 300
50	4 000	3 000	3 500	1 000	7 800	6 200	9 000
65	4 000	3 000	3 500	1 500	7 500	6 000	8 700
80	4 000	3 000	3 500	1 500	7 300	5 800	8 400
100	4 000	3 000	3 500	900	7 100	5 600	8 100
125	4 000	3 000	3 500	700	6 900	5 400	7 800
150	4 000	3 000	3 500	500	6 700	5 300	7 500
200	4 000	3 000	3 500	A	6 400	5 100	7 200
250	4 000	3 000	3 500	A	6 200	4 900	7 000
300	4 000	3 000	3 500	A	6 000	4 800	6 800
350	—	3 000	3 500	A	5 900	4 700	6 600
400	—	3 000	3 500	A	5 800	4 600	6 500
450	—	3 000	3 500	A	5 700	4 550	6 350
500	—	3 000	3 500	A	5 600	4 500	6 200

NOTE 1 C/S: carbon steel as defined in 6.1.2.a).
 NOTE 2 S/S: stainless steel as defined in 6.1.2.b).
 NOTE 3 A: refer to manufacturer.

6.5 Temperature

6.5.1 Maximum allowable working temperature

The maximum allowable working temperature of a stripwound metal hose assembly shall be the maximum allowable working temperature of the assembly component with the lowest temperature resistance; such assembly components may be:

- hose or end fitting material;
- protection;
- packing;
- assembly method.

EXAMPLE The maximum allowable working temperature may depend on the basic packing material such as:

- rubber packing: up to $\approx 60^{\circ}\text{C}$;
- copper packing: up to $\approx 600^{\circ}\text{C}$.

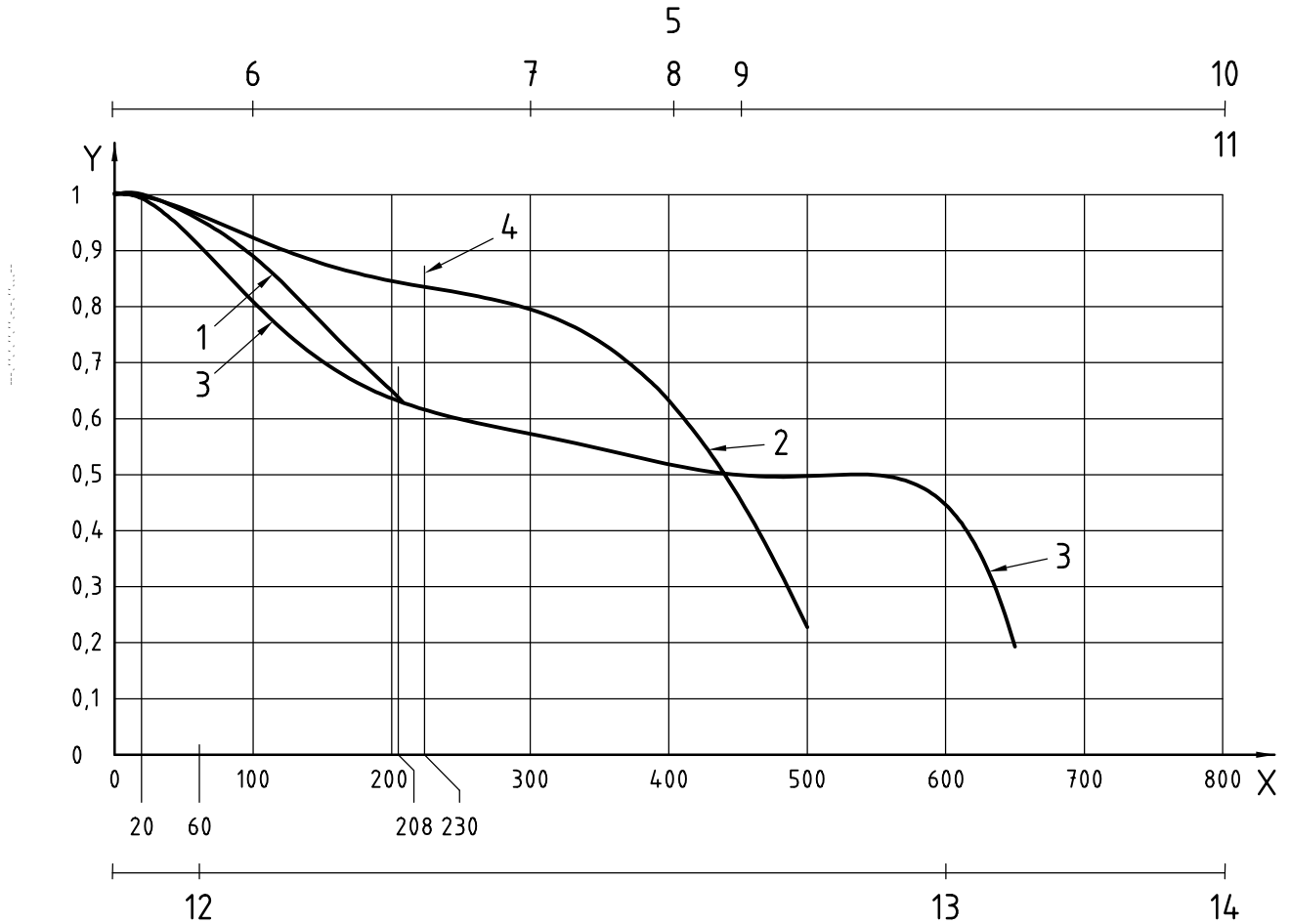

Key

- | | | | |
|---|--|----|--|
| X | maximum allowable service temperature $^{\circ}\text{C}$ | 7 | silver brazing |
| Y | temperature de-rating factor | 8 | brazing |
| 1 | bronze | 9 | welding of carbon steel hose and fittings |
| 2 | carbon steel | 10 | welding of stainless steel hose and fittings |
| 3 | austenitic stainless steel | 11 | mechanical fittings |
| 4 | temperature limit for galvanized steel | 12 | rubber packing |
| 5 | end fitting attachment limitations | 13 | copper packing |
| 6 | solder | 14 | unpacked |

NOTE 1 The curve for galvanized steel is the same as one for unalloyed steel (carbon steel). The temperature limit is 230°C .

NOTE 2 Typical limitations of packing and fitting attachment methods are shown in the figure.

Figure 5 — Temperature de-rating factors and upper temperature limitations for materials and end fitting attachment methods

6.5.2 Maximum allowable working pressure at elevated temperature

Figure 5 gives guidance on the effect of temperature on materials and assembly methods. The maximum permissible pressure of the hose assembly at any temperature shall be the lowest value of the pressure at 20 °C of each component multiplied by its appropriate de-rating factor.

For more detailed information on temperature derating factors, see ISO 10380.

6.6 Pressure (for type DOP hose only)

6.6.1 Burst pressure

When tested in accordance with 7.4, the burst pressure shall not be less than three times the maximum allowable pressure given in Table 1.

6.6.2 Maximum allowable pressure

When tested in accordance with 7.1, the hose or hose assembly shall not leak (see Table 1).

6.7 Assembly

6.7.1 Mechanical fittings

Mechanical fittings may be either packed or unpacked.

a) Packed fittings

Packed fittings shall be leakproof, screwed on to the hose, packed and locked.

b) Unpacked fittings

Unpacked fittings shall be screwed on to the hose and locked.

6.7.2 Plain Fittings

Plain fittings shall be attached to the hose by one of the following methods:

- soft soldering;
- brazing;
- welding;
- swaging;
- adhesive bonding.

The upper temperature limit of these methods is indicated in Figure 5.

7 Type tests

7.1 Tensile strength test

The test-piece is fitted with a screwed or screwed and packed or welded end fitting, with a free length between ends of at least 400 mm.

A slowly increasing regular strain is applied to the test-piece. The load is applied progressively so that elongation takes place with a constant speed of 0,5 mm/s.

The maximum load withstood by the test-piece before rupture is considered to be the tensile strength value (see Figure 6). Tensile strength is expressed in newtons.

The value of tensile strength shall be higher than or equal to the one shown in Table 2.

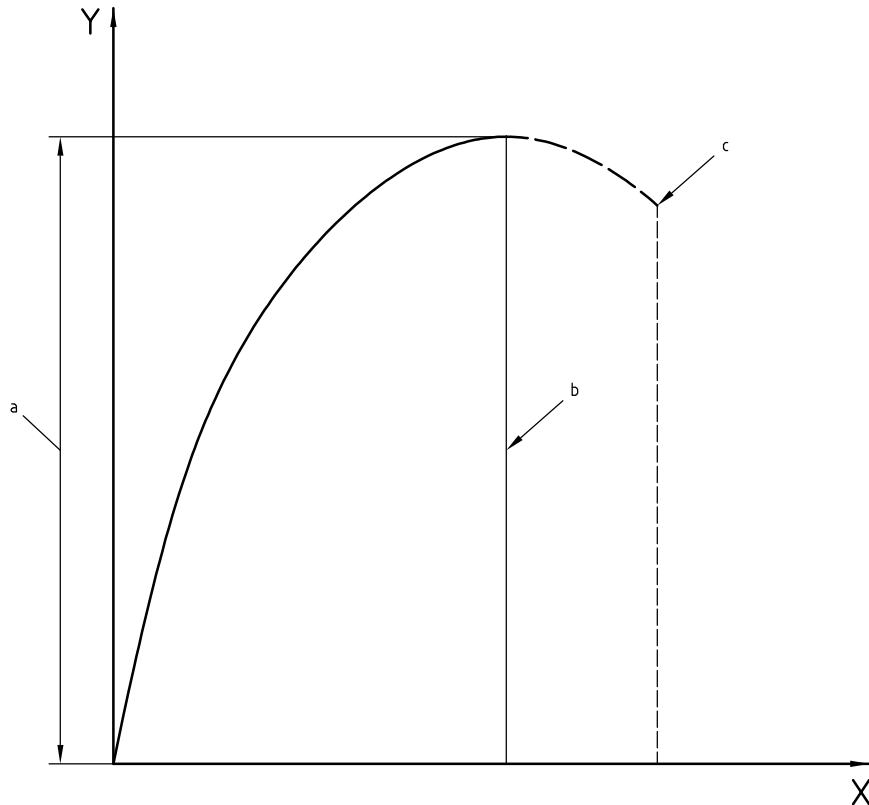

Key

X elongation, %
Y tensile load, N

a Tensile strength.

b Maximum load.

c Rupture point.

Figure 6 — Tensile strength diagram

7.2 Crush strength test

The length of the test-piece shall be

- 500 mm for DN 100 and below;
- five times the external diameter for DN above 100 with a maximum of 1 000 mm.

The test-piece is placed horizontally and drawn taut (or drawn, without compressed set for rubber packing) in the compression test device, between two parallel steel plates with a length of 200 mm and a width equal to or greater than the hose diameter. The ends of the hose shall be at least 100 mm from the ends of the test plates. Load is gradually applied to compress the test piece at a continuous rate of 0,5 mm/s. The curve and/or deformation point shall then be recorded.

The value resulting in the permanent reduction of the inside diameter, d , by 5 % shall be considered to be the crush strength (see Figure 7). This resistance shall be expressed in newtons. This value shall be at least equal to or more than the values shown in Table 3.

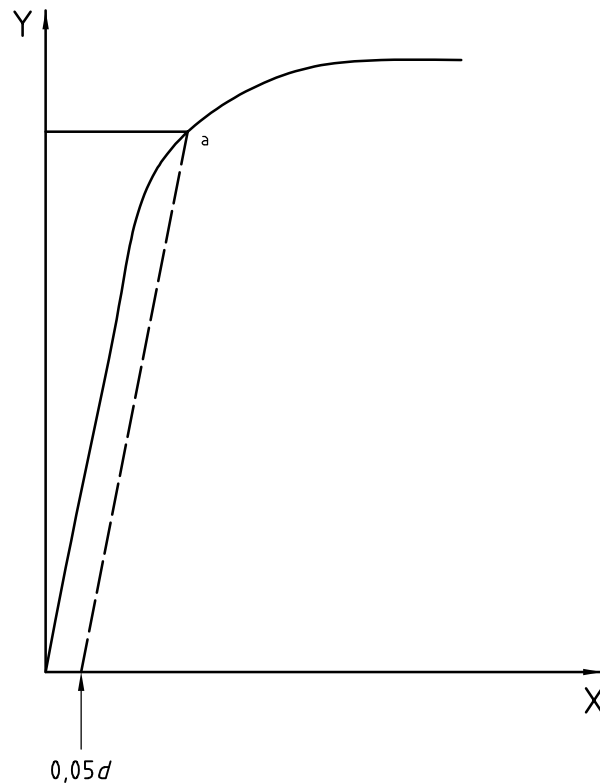

Key

- X crush
- Y compression load
- a Crush strength.

Figure 7 — Crush strength diagram

7.3 Bend test

When coiled, the bend radius of all hoses shall not exceed the value given in Table 1. For very short lengths of hose, or for large bore hose, the coiling diameter and the bend radius shall be calculated by the following method.

The metal hose is coiled to its minimum bend radius. The inside diameter of the coil shall be equal to the coiling diameter E .

For large diameters (especially for small lengths), a 1 000 mm ruler is applied to the coil. The distance h is measured in the middle of the ruler (see Figure 8): the coiling diameter E is calculated by the formula

$$E = \frac{250\,000}{h} + h$$

and the bend radius R by the formula

$$R = \frac{E + D}{2}$$

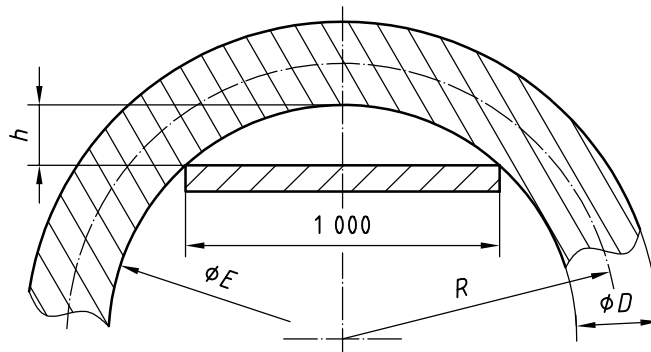

Figure 8 — Coiling of a large diameter hose

7.4 Pressure test (for type DOP hose)

The test-piece is placed flat and unfixed at a standard temperature in accordance with ISO 554. A constantly increased hydraulic pressure is applied until beads of water appear on the outside of the test-piece. The pressure reached at this moment is called the “burst pressure”. It is expressed in bar.

8 Production tests — Pressure proof test (for type DOP hose)

The hose assembly is placed on a horizontal surface and allowed to move freely. It is subjected to a hydraulic pressure of one and a half times the maximum allowable pressure. The pressure shall be maintained for a minimum of 1 min, at ambient temperature. There shall be no visible leakage or deformation.

9 Designation

Stripwound metal hose and hose assemblies in accordance with this International Standard shall be designated by:

- a) reference to this International Standard, i.e. ISO 15465;
- b) hose type;
- c) strip material;
- d) nominal size, DN;
- e) maximum allowable pressure (for type DOP only);
- f) maximum allowable temperature (for SOP and DOP).

EXAMPLE 1 A single overlap carbon steel hose, unpacked, nominal size DN 40, is designated as follows:

ISO 15465 - SOU - C/S - DN 40

EXAMPLE 2 A double overlap stainless steel hose, pressure packed, nominal size 40, maximum allowable pressure of 31 bar and maximum temperature 60 °C, is designated as follows:

ISO 15465 - DOP - S/S - DN 40 - 31 bar - 60 °C

10 Marking

Hose assemblies shall carry, as a minimum, the following marking:

- a) name of manufacturer or trademark;
- b) year of manufacture;
- c) designation in accordance with Clause 9.

10

Bibliography

- [1] ISO 6708, *Pipework components — Definition and selection of DN (nominal size)*

ICS 23.040.70

Price based on 13 pages