**Animal and vegetable fats and oils —
Determination of sediment in crude fats and
oils — Centrifuge method**

*Corps gras d'origines animale et végétale — Détermination de la teneur en
sédiment dans des corps gras bruts — Méthode par centrifugation*



PDF disclaimer

This PDF file may contain embedded typefaces. In accordance with Adobe's licensing policy, this file may be printed or viewed but shall not be edited unless the typefaces which are embedded are licensed to and installed on the computer performing the editing. In downloading this file, parties accept therein the responsibility of not infringing Adobe's licensing policy. The ISO Central Secretariat accepts no liability in this area.

Adobe is a trademark of Adobe Systems Incorporated.

Details of the software products used to create this PDF file can be found in the General Info relative to the file; the PDF-creation parameters were optimized for printing. Every care has been taken to ensure that the file is suitable for use by ISO member bodies. In the unlikely event that a problem relating to it is found, please inform the Central Secretariat at the address given below.

© ISO 2001

All rights reserved. Unless otherwise specified, no part of this publication may be reproduced or utilized in any form or by any means, electronic or mechanical, including photocopying and microfilm, without permission in writing from either ISO at the address below or ISO's member body in the country of the requester.

ISO copyright office
Case postale 56 • CH-1211 Geneva 20
Tel. + 41 22 749 01 11
Fax + 41 22 749 09 47
E-mail copyright@iso.ch
Web www.iso.ch

Printed in Switzerland

Foreword

ISO (the International Organization for Standardization) is a worldwide federation of national standards bodies (ISO member bodies). The work of preparing International Standards is normally carried out through ISO technical committees. Each member body interested in a subject for which a technical committee has been established has the right to be represented on that committee. International organizations, governmental and non-governmental, in liaison with ISO, also take part in the work. ISO collaborates closely with the International Electrotechnical Commission (IEC) on all matters of electrotechnical standardization.

International Standards are drafted in accordance with the rules given in the ISO/IEC Directives, Part 3.

Draft International Standards adopted by the technical committees are circulated to the member bodies for voting. Publication as an International Standard requires approval by at least 75 % of the member bodies casting a vote.

Attention is drawn to the possibility that some of the elements of this International Standard may be the subject of patent rights. ISO shall not be held responsible for identifying any or all such patent rights.

International Standard ISO 15301 was prepared by Technical Committee ISO/TC 34, *Food products*, Subcommittee SC 11, *Animal and vegetable fats and oils*.

Annexes A and B of this International Standard are for information only.

Animal and vegetable fats and oils — Determination of sediment in crude fats and oils — Centrifuge method

1 Scope

This International Standard specifies a method for the determination in crude fats or oils of that sediment which can be separated by centrifugal force.

The method is applicable to crude oils and to oils with a sediment content of 0,03 ml per 100 g to 15 ml per 100 g, obtained by means of extraction and/or crushing.

The method is not applicable to fats which are not liquid at a temperature of 20 °C.

2 Normative reference

The following normative document contains provisions which, through reference in this text, constitute provisions of this International Standard. For dated references, subsequent amendments to, or revisions of, any of these publications do not apply. However, parties to agreements based on this International Standard are encouraged to investigate the possibility of applying the most recent edition of the normative document indicated below. For undated references, the latest edition of the normative document referred to applies. Members of ISO and IEC maintain registers of currently valid International Standards.

ISO 661:1989, *Animal and vegetable fats and oils — Preparation of test sample*

3 Term and definition

For the purposes of this International Standard, the following term and definition applies.

3.1

sediment

that part of the insoluble matter in a crude fat or oil which can be centrifugally separated and is the total amount of the unclear layer of components collected at the bottom of the measuring tube after centrifuging

NOTE The sediment contains, for example, phospholipids, impurities, dirt, etc. dispersed in a water-containing phase, and can be quantified according to this International Standard. Any white crystalline components deposited on top of and within the dark layer of insoluble materials are regarded as part of the sediment.

4 Principle

A homogenized test sample is subjected to centrifuging as specified. The amount of separated material, called sediment, is volumetrically measured in a calibrated centrifuge tube.

5 Apparatus

Usual laboratory apparatus and, in particular, the following.

5.1 Centrifuge tubes, of capacity 100 ml, pear- or cone-shaped, made from thoroughly annealed glass and fitted with a stopper (see Figures 1 and 2).

NOTE Reading the volume of the unclear layer may be more difficult in a cone-shaped tube than in a pear-shaped tube.

5.2 Buckets, for centrifuge tubes (5.1), resistant to fats and oils.

5.3 Centrifuge, suitable for the centrifuge tubes (5.1) placed in the buckets (5.2), capable of controlling the rotational frequency so as to give a radial acceleration at the narrow part of the tubes of 700 to 800 times the acceleration of free fall.

See annex A for the calculation of the rotational frequency of the centrifuge.

In rooms which are not air-conditioned, use a centrifuge capable of maintaining its temperature between 20 °C and 25 °C.

5.4 Balance, capable of weighing to the nearest 0,1 g.

6 Sampling

It is important that the laboratory receive a sample which is truly representative and has not been damaged or changed during transport or storage.

Sampling is not a part of the method specified in this International Standard. A recommended sampling method is given in ISO 5555 [1].

Store samples in glass or polyethylene terephthalate (PET) bottles.

7 Preparation of test sample

Prepare the test sample in accordance with ISO 661.

Bring the test sample, if necessary, to a temperature of between 20 °C and 25 °C.

Redisperse any sediment in the oil from the bottom of the sample bottle to ensure a sufficiently homogeneous and representative sample. Immediately proceed in accordance with clause 8.

8 Procedure

Weigh two centrifuge tubes (5.1) to the nearest 0,1 g. Transfer 100 ml of the prepared test sample (clause 7) to each of the centrifuge tubes. Weigh the tubes and place them in the buckets (5.2) in the centrifuge (5.3). Adjust the rotational frequency so as to give a radial acceleration at the narrow part of tubes of 700 to 800 times the acceleration of free fall. Centrifuge for 1 h \pm 5 s.

Read sediment volumes up to and including 1,5 ml to the nearest 0,03 ml. Read sediment volumes greater than 1,5 ml to the nearest 0,5 ml.

When using a cone-shaped tube, it may be more difficult to read the volume of the unclear layer; read the sediment volumes as accurately as possible.

If in a pear-shaped tube the separation is not complete (clear layer in the neck of the narrow tube section of the tube), the sediment reading should be corrected for this volume.

Record the relative radial acceleration or the swing diameter and the rotational frequency of the centrifuge.

Record the temperature before and after centrifuging.

9 Expression of results

Calculate the sediment content of the test sample using the equation:

$$w = \frac{V \times 100}{(m_1 - m_2)}$$

where

w is the numerical value of the sediment content of the test sample, in millilitres per 100 g;

V is the numerical value of the sediment volume, in millilitres;

m_1 is the numerical value of the mass of the centrifuge tube with the test portion, in grams;

m_2 is the numerical value of the mass of the centrifuge tube, in grams.

Calculate the mean of the results for the two tubes and report the results to the nearest 1 ml per 100 g.

10 Precision

10.1 Interlaboratory test

Details of interlaboratory tests on the precision of the method are given in annex B. The values derived from these tests may not be applicable to concentration ranges and matrices other than those given.

10.2 Repeatability

The absolute difference between two independent single test results, obtained using the same method on identical test material in the same laboratory by the same operator using the same equipment within a short interval of time, will in not more than 5 % of cases exceed the repeatability limit r given in or derived from Table 1.

Table 1 — Repeatability limit (r) and reproducibility limit (R)

Sediment content ml per 100 g	r ml per 100 g	R ml per 100 g
< 1	0,1	0,7
1 to 3	0,2	1,0

10.3 Reproducibility

The absolute difference between two single test results, obtained using the same method on identical test material in different laboratories by different operators using different equipment, will in not more than 5 % of cases exceed the reproducibility limit R given in or derived from Table 1.

11 Test report

The test report shall specify:

- all information necessary for the complete identification of the sample;
- the sampling method used, if known;
- the test method used, with reference to this International Standard;
- the relative radial acceleration or the swing diameter and the rotational frequency;

- the temperature before and after centrifuging;
- all operating details not specified in this International Standard, or regarded as optional, together with details of any incidents which may have influenced the test result(s);
- the test result obtained, or the two test results obtained if the repeatability has been checked.

Dimensions in millimetres

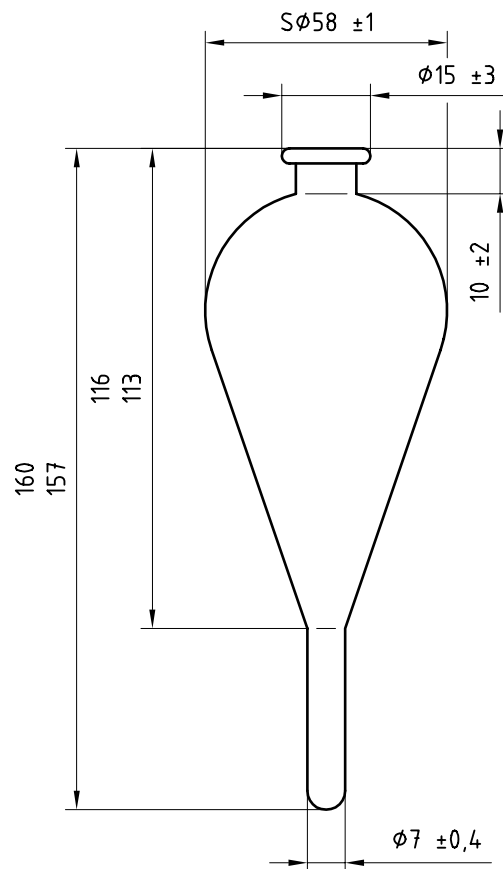

Figure 1 — Pear-shaped sediment tube

Dimensions in millimetres

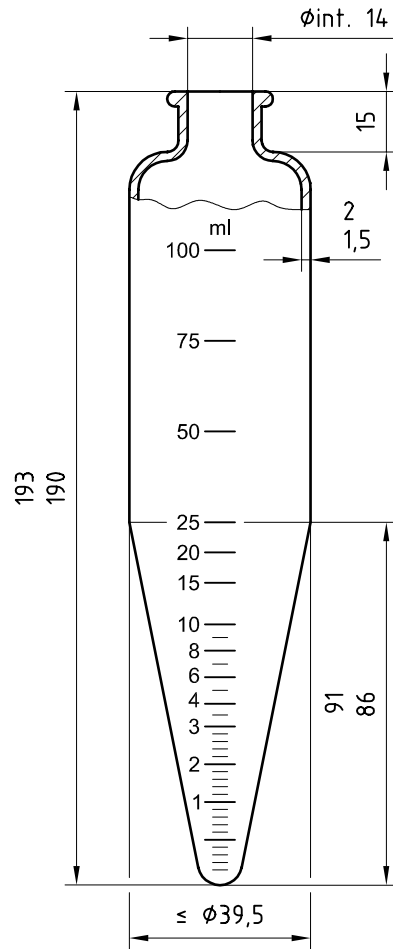

Figure 2 — Cone-shaped sediment tube

Annex A (informative)

Calculation of the rotational frequency of a centrifuge

The rotational frequency of the centrifuge may be calculated by the equation:

$$n = 1\,337 \sqrt{\frac{a_r}{d}}$$

where

n is the numerical value of the rotational frequency, in min^{-1} ;

a_r is the relative radial acceleration (for example $a_r = 700$ or $a_r = 800$);

d is the numerical value of the diameter of swing, measured between the tips of opposite tubes when tubes are in a rotating position, in millimetres.

Annex B (informative)

Results of interlaboratory tests

B.1 Statistical results of interlaboratory tests

The precision of the method was established by two interlaboratory tests organized by the Netherlands Oils, Fats and Oilseeds Trade Association (NOFOTA) in cooperation with the Federation of Oils, Seeds and Fats Associations (FOSFA International) in 1996 and 1997/1998 and carried out in accordance with ISO 5725-2 [3]. In the first test 12 laboratories participated. Six (spiked) samples of crude sunflowerseed oil were investigated. In the second test 9 laboratories participated. Four (spiked) samples of crude sunflowerseed oil were investigated.

See Tables B.1 and B.2 for a summary of the statistical results of the tests.

Table B.1 — Statistical results of the interlaboratory test organized in 1996

Parameter	Sample					
	1	2	3	4	5	6
Number of laboratories retained after eliminating outliers	12	12	12	11	10	11
Mean sediment content, ml per 100 g	0,75	1,36	0,54	1,62	2,07	2,61
Repeatability standard deviation (s_r), ml per 100 g	0,04	0,06	0,04	0,06	0,03	0,07
Repeatability coefficient of variation, %	4,76	4,29	6,85	3,60	1,59	2,78
Repeatability limit (r) [$r = 2,8 \times s_r$], ml per 100 g	0,10	0,16	0,10	0,16	0,09	0,20
Reproducibility standard deviation (s_R), ml per 100 g	0,26	0,22	0,26	0,28	0,26	0,35
Reproducibility coefficient of variation, %	34,6	16,0	47,9	17,2	12,6	13,5
Reproducibility limit (R) [$R = 2,8 \times s_R$], ml per 100 g	0,72	0,61	0,72	0,78	0,73	0,99

Table B.2 — Statistical results of the interlaboratory test organized in 1997/1998

Parameter	Sample			
	1	2	3	4
Number of laboratories retained after eliminating outliers	7	8	8	7
Mean sediment content, ml per 100 g	0,07	1,28	1,20	2,39
Repeatability standard deviation (s_r), ml per 100 g	0,00	0,04	0,04	0,00
Repeatability coefficient of variation, %	0,00	2,77	2,95	0,00
Repeatability limit (r) [$r = 2,8 \times s_r$], ml per 100 g	0,00	0,10	0,10	0,00
Reproducibility standard deviation (s_R), ml per 100 g	0,07	0,12	0,08	0,35
Reproducibility coefficient of variation, %	97,8	9,1	7,0	14,8
Reproducibility limit (R) [$R = 2,8 \times s_R$], ml per 100 g	0,20	0,33	0,24	0,99

B.2 Comparison with the 96 h method

In the two interlaboratory tests, the centrifuge method was compared with the method which leaves the test sample to stand at a controlled temperature for 96 h.

Applying regression analysis to the results of both interlaboratory tests for the relation between the two methods, the following equation was established (with a correlation coefficient of 0,96):

$$w_2 = 2,5 w_1 - 0,5$$

where

w_1 is the numerical value of the sediment content obtained with the 96 h method, in millilitres per 100 ml;

w_2 is the numerical value of the sediment content obtained with the centrifuge method, in millilitres per 100 g.

This indicates that the centrifuge method may be considered as a good alternative to the 96 h method, where a rapid control method is required for levels of sediment exceeding 0,5 ml per 100 ml.

Bibliography

- [1] ISO 5555:1991, *Animal and vegetable fats and oils — Sampling*
- [2] ISO 5725-1:1994, *Accuracy (trueness and precision) of measurement methods and results — Part 1: General principles and definitions*
- [3] ISO 5725-2:1994, *Accuracy (trueness and precision) of measurement methods and results — Part 2: Basic method for the determination of repeatability and reproducibility of a standard measurement method*

