Oscillation-type density meters —
Part 2:
Process instruments for homogeneous
liquids

Densimètres à oscillation —

Partie 2: Instruments industriels pour liquides homogènes



Reference number
ISO 15212-2:2002(E)

© ISO 2002

PDF disclaimer

This PDF file may contain embedded typefaces. In accordance with Adobe's licensing policy, this file may be printed or viewed but shall not be edited unless the typefaces which are embedded are licensed to and installed on the computer performing the editing. In downloading this file, parties accept therein the responsibility of not infringing Adobe's licensing policy. The ISO Central Secretariat accepts no liability in this area.

Adobe is a trademark of Adobe Systems Incorporated.

Details of the software products used to create this PDF file can be found in the General Info relative to the file; the PDF-creation parameters were optimized for printing. Every care has been taken to ensure that the file is suitable for use by ISO member bodies. In the unlikely event that a problem relating to it is found, please inform the Central Secretariat at the address given below.

© ISO 2002

All rights reserved. Unless otherwise specified, no part of this publication may be reproduced or utilized in any form or by any means, electronic or mechanical, including photocopying and microfilm, without permission in writing from either ISO at the address below or ISO's member body in the country of the requester.

ISO copyright office
Case postale 56 • CH-1211 Geneva 20
Tel. + 41 22 749 01 11
Fax + 41 22 749 09 47
E-mail copyright@iso.ch
Web www.iso.ch

Printed in Switzerland

Contents

	Page
1 Scope	1
2 Normative references	1
3 Terms and definitions	2
4 Principle and functional units	2
4.1 Measuring principle	2
4.2 Functional units	2
5 Density sensor	4
5.1 Sensor material	4
5.2 Sensor design	4
6 Requirements and tests	4
6.1 General	4
6.2 Density measuring transducer	4
6.3 Liquid temperature measurement	6
6.4 Display and output of results	7
6.5 Auxiliary units and data transfer	7
6.6 Safety requirements	8
6.7 Electromagnetic compatibility	8
7 Preadjustment and adjustment	8
7.1 Preadjustment of process density meters	8
7.2 Preadjustment of density measuring transducers	8
7.3 Adjustment of installed density measuring transducers	8
7.4 Adjustment of processing units	8
8 Calibration	9
8.1 Laboratory calibration	9
8.2 In-situ calibration	11
9 Process density meter accuracy	13
9.1 Accuracy requirements	13
9.2 Laboratory conformity test	13
9.3 In-situ tests	14
9.4 Test procedure and conformity assessment	14
10 Installation	15
11 Operating manual	15
12 Marking	16

Foreword

ISO (the International Organization for Standardization) is a worldwide federation of national standards bodies (ISO member bodies). The work of preparing International Standards is normally carried out through ISO technical committees. Each member body interested in a subject for which a technical committee has been established has the right to be represented on that committee. International organizations, governmental and non-governmental, in liaison with ISO, also take part in the work. ISO collaborates closely with the International Electrotechnical Commission (IEC) on all matters of electrotechnical standardization.

International Standards are drafted in accordance with the rules given in the ISO/IEC Directives, Part 3.

Draft International Standards adopted by the technical committees are circulated to the member bodies for voting. Publication as an International Standard requires approval by at least 75 % of the member bodies casting a vote.

Attention is drawn to the possibility that some of the elements of this part of ISO 15212 may be the subject of patent rights. ISO shall not be held responsible for identifying any or all such patent rights.

International Standard ISO 15212-2 was prepared by Technical Committee ISO/TC 48, *Laboratory glassware and related apparatus*, Subcommittee SC 4, *Density measuring instruments*.

ISO 15212 consists of the following parts, under the general title *Oscillation-type density meters*:

- *Part 1: Laboratory instruments*
- *Part 2: Process instruments for homogeneous liquids*

Introduction

Density values of pure water at different temperatures and information on how to calculate the density values at different pressures can be found in ISO 15212-1:1998, annex A.

.....

Oscillation-type density meters —

Part 2:

Process instruments for homogeneous liquids

1 Scope

This part of ISO 15212 specifies metrological requirements, among others, for oscillation-type density meters as well as for functional units (see 4.2) of oscillation-type density meters, which are used in process for all kinds of homogeneous liquids. This includes liquified gases. Instructions and methods for installation, preadjustment, adjustment and calibration of process instruments are also given. The instruments are either integral systems or functional units, which can be combined into an integral measuring system.

This part of ISO 15212 does not describe the method of use of process density meters for particular applications or products, e.g. petroleum products or beverages. Such methods of use can be defined by relevant institutions such as ISO or responsible Government agencies.

This part of ISO 15212 does not define an instrument specification for any particular application. For this information reference should be made to the relevant standard covering the method of use.

This part of ISO 15212 is addressed to manufacturers of density meters and to bodies, testing and certifying the conformity of density meters. This part of ISO 15212 also gives recommendations for adjustment and calibration of process density meters.

Oscillation-type density meters used in laboratories are addressed in ISO 15212-1.

2 Normative references

The following normative documents contain provisions which, through reference in this text, constitute provisions of this part of ISO 15212. For dated references, subsequent amendments to, or revisions of, any of these publications do not apply. However, parties to agreements based on this part of ISO 15212 are encouraged to investigate the possibility of applying the most recent editions of the normative documents indicated below. For undated references, the latest edition of the normative document referred to applies. Members of ISO and IEC maintain registers of currently valid International Standards.

ISO 15212-1:1998, *Oscillation-type density meters — Part 1: Laboratory instruments*

IEC 61010-1, *Safety requirements for electrical equipment for measurement, control and laboratory use — Part 1: General requirements*

IEC 61326-1, *Electrical equipment for measurement, control and laboratory use — EMC requirements*

Guide to the Expression of Uncertainty in Measurement (GUM). BIPM, IEC, IFCC, ISO, IUPAC, IUPAP, OIML

3 Terms and definitions

For the purposes of this part of ISO 15212, the terms and definitions given in ISO 15212-1 and the following apply.

3.1

preadjustment

(process density meter) adjustment performed in a laboratory environment before installation

NOTE Adjustment, see 3.1 of ISO 15212-1:1998.

3.2

laboratory calibration

(process density meter) calibration for the intended entire working range of the instrument performed in a laboratory environment before installation

NOTE Calibration, see 3.2 of ISO 15212-1:1998.

3.3

***in-situ* calibration**

(process density meter) calibration of the installed instrument for its actual working conditions in a process environment

4 Principle and functional units

4.1 Measuring principle

The sensors used in density meters are electrically or mechanically induced oscillating systems, whose oscillation frequencies or periods are a function of the liquid density. Depending on the sensor design, the liquid can either flow through the sensor or the sensor can be immersed in the liquid. Instrument constants of the adjusted density meter are used to calculate the sample density from the oscillation frequency or oscillation period and from associated measurements, e.g. temperature or pressure.

4.2 Functional units

Oscillation-type process density meters shall consist of the following functional units:

- a) a density sensor through which the liquid flows or which is immersed in the liquid;
- b) a device to determine the density sensor temperature;
- c) a device to condition and/or preamplify the density sensor signal;
- d) a device to condition and/or preamplify the temperature sensor signal;
- e) a unit for signal processing, output of results and functional monitoring.

Optional functional units of process density meters may be:

- f) a temperature transducer to measure the liquid temperature (see item 6 in Figure 1);
- g) a pressure transducer to measure the liquid pressure (see item 7 in Figure 1).

The functional units a) to d) are often referred to as density measuring transducer (see item 8 in Figure 1). The unit e) can be referred to as processing or indicating unit (see item 5 in Figure 1) and may accept additional signals or process parameters, e.g. from a flow meter.

The functional units, items 5 and 8 in Figure 1, can be integrated into a single instrument or can be separate units.

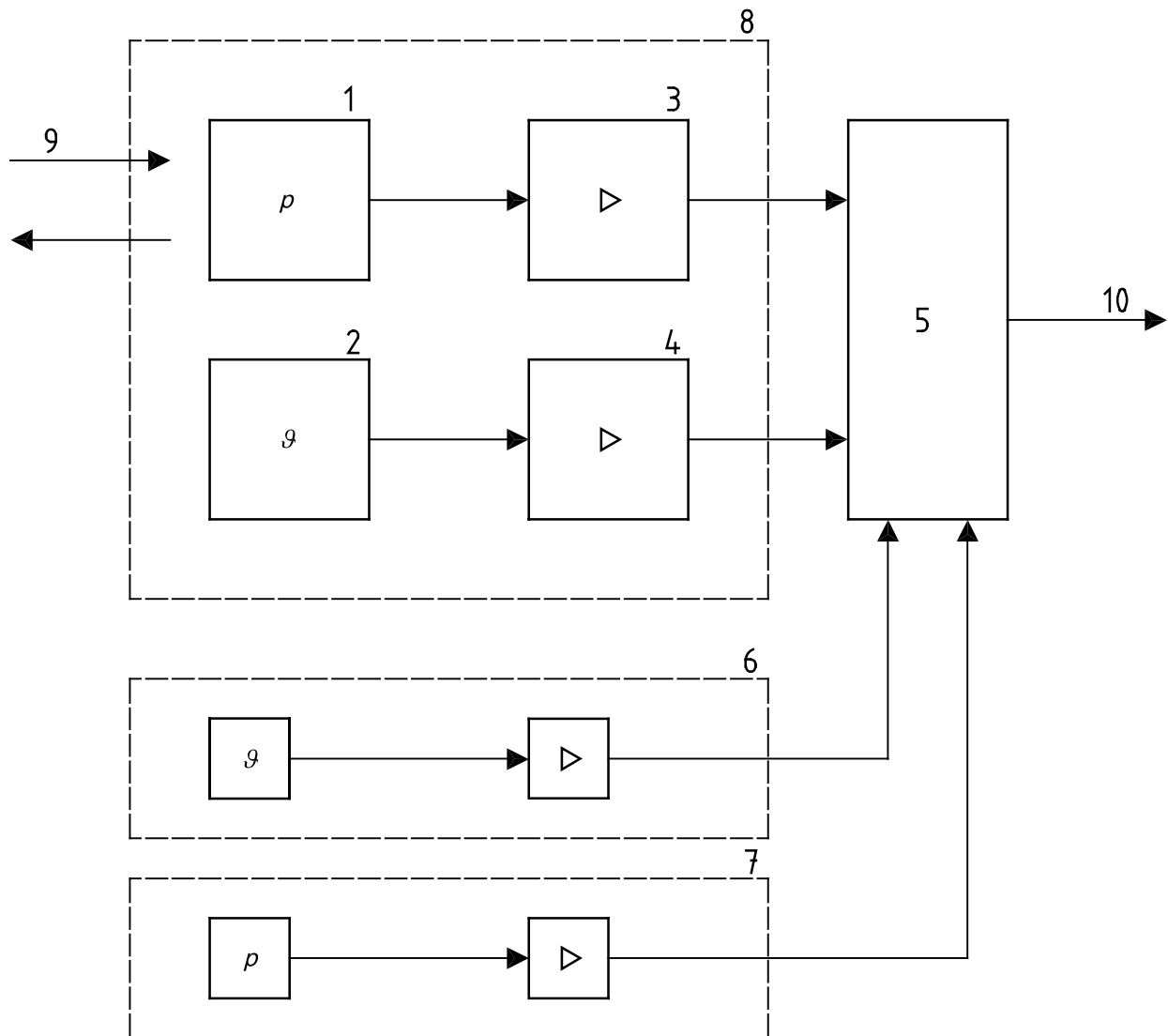

Key

- 1 Density sensor [see 4.2 a)]
- 2 Temperature sensor [see 4.2 b)]
- 3 Density sensor signal preamplification [see 4.2 c)]
- 4 Temperature sensor signal preamplification [see 4.2 d)]
- 5 Processing or indicating unit [see 4.2 e)]
- 6 Temperature transducer [see 4.2 f)]
- 7 Pressure transducer [see 4.2 g)]
- 8 Density measuring transducer
- 9 Liquid to be measured
- 10 Output (display, printer, interface)

Figure 1 — Functional units of a process density meter

5 Density sensor

5.1 Sensor material

Density sensor materials can be, for example, metal, metal alloys, coated metals or glass. The material is considered to be suitable if it is compatible with the process liquids to be measured at the process conditions and with the cleaning agents to be used in the density meter. Erosion, abrasion as well as special forms of corrosion shall be considered in this respect since they have an impact on the accuracy of the instrument. The manufacturer shall provide certificates about the sensor material on request.

5.2 Sensor design

Density sensors can be designed as straight, U-formed or omega-formed tubes. Other designs are tuning-forks, cylinders, bells or membranes. All designs which conform with the functional principle in accordance with 4.1 can be constructed.

6 Requirements and tests

6.1 General

All the tests of this clause are intended to be type tests.

6.2 Density measuring transducer

6.2.1 Drift

6.2.1.1 Within 30 days, the drift of the measured density $\Delta\rho_{30}$ at a temperature of 20 °C, at a pressure of 0,1 MPa to 0,2 MPa¹⁾ (1 bar to 2 bar) and at a typical flow rate specified in the manual shall not exceed 20 % of the maximum permissible error specified by the manufacturer for the instrument.

If the working range of the density meter does not include the above mentioned conditions, the drift at the typical measuring conditions of the density meter shall not exceed 40 % of the specified maximum permissible error.

6.2.1.2 The test for the drift determination shall be performed as follows:

- install the instrument, preadjusted by the manufacturer, to a liquid circulation system; suited liquids can be for example water or mineral oil;
- switch on the instrument and attemper it for 24 h;
- circulate the liquid through the instrument and record the density at least three times at $(20 \pm 0,1)$ °C within 30 min;
- record the mean value ρ_1 of the density measurement;
- repeat the density measurement (without a new adjustment) and mean value calculation ρ_2 after a minimum of 30 days.

1) 1 bar = 10^5 N/m² = 0,1 MPa.

Instrument, liquid circulation and thermostating device shall be in operation during the whole test.

During the minimum time period of 30 days between the two density measurements, the instrument shall be run at least 2 days at a temperature of $(10 \pm 1) ^\circ\text{C}$ and another 2 days at a temperature of $(30 \pm 1) ^\circ\text{C}$.

To calculate the drift, $\Delta\rho_{30}$, use the following equation:

$$\Delta\rho_{30} = \frac{\rho_1 - \rho_2}{\Delta t} \quad (1)$$

where Δt is the difference in days between the two threefold measurements.

If the density measuring transducer is not designed for a measuring temperature of $20 ^\circ\text{C}$, testing shall be performed at the mean measuring temperature of the density measuring transducer. The increased and decreased temperature between the two density measurements shall be $+10 ^\circ\text{C}$ and $-10 ^\circ\text{C}$ from this mean measuring temperature.

6.2.2 Effect of liquid properties

6.2.2.1 The density measuring transducer shall be constructed in such a way, that the maximum permissible errors are in accordance with the requirements given in 9.1 when measuring liquids with different sound velocities and, where appropriate, having different viscosities.

6.2.2.2 For testing, use Newtonian liquids with known densities and sound velocities as well as, where appropriate, known viscosities. They shall cover the intended application range of the density meter specified by the manufacturer with regard to sound velocity and viscosity. Testing shall be performed in accordance with 9.2.

6.2.3 Deviation between liquid and sensor temperatures

6.2.3.1 The density measuring transducer shall be designed to minimize the deviation between liquid temperature and sensor temperature. The density deviations due to this temperature deviation at constant flow and temperature shall not exceed 50 % of the specified maximum permissible error of the density measuring transducer.

6.2.3.2 Testing shall be performed by comparing the densities determined by the density measuring transducer with the actual densities of a suitable test liquid of known density at three different temperatures, being approximately the lower, upper and mean value of the specified liquid temperature range. Ambient temperature shall be kept constant to within $\pm 1 ^\circ\text{C}$ of the mean value for the specified ambient temperature range of the density measuring transducer. For this test

- switch on the density measuring transducer and circulate the test liquid for at least 1 h at a temperature as specified above and at a suitable flow rate;
- determine the actual liquid temperature as mean value of the temperatures at the inlet and outlet of the density transducer, measured by suitable thermometers;
- calculate the deviation between the actual density of the test liquid of known density at the actual liquid temperature and the density displayed by the density measuring transducer;
- repeat the test at the two other temperatures specified above.

Ethanol, *n*-nonane or mineral oil are suitable test liquids for this test.

6.2.4 Effect of instrument parts oscillations

6.2.4.1 Measurement deviations arising from parasitic resonances of instrument parts on the density measuring transducer shall not exceed 35 % of the maximum permissible error over the whole measuring range, specified for the density measuring transducer by the manufacturer.

6.2.4.2 For testing, examine the oscillatory characteristics of the built-in density sensor provided by the manufacturer. This test may not show any parasitic resonant points (see 3.3 of ISO 15212-1:1998) whose effects

exceed 35 % of the maximum permissible error specified for the density measuring transducer by the manufacturer over the whole density measurement range.

6.2.5 Effect of instrument positioning

6.2.5.1 Unless otherwise specified by the manufacturer, the maximum permissible errors, in accordance with Table 2 or in accordance with the manufacturer's specifications (see 9.1), shall not be exceeded if the position of the instrument is turned 90° from the vertical and horizontal sample flow direction.

6.2.5.2 Testing shall be performed in all three positions in accordance with 9.2 at constant temperature, pressure and density.

6.3 Liquid temperature measurement

6.3.1 Built-in temperature sensor

6.3.1.1 If the process density meter is equipped with a built-in liquid temperature measurement, the temperature sensor shall be fitted in such a way, that a good thermal contact with the liquid is guaranteed. The deviation between the displayed and actual liquid temperatures shall not be greater than the maximum permissible error of the density measuring transducer multiplied by the factor $0,2 \text{ }^{\circ}\text{C} \times \text{kg}^{-1} \times \text{m}^3$.

NOTE This factor has been defined by assuming an extreme thermal density deviation of $2,4 \text{ kg} \times \text{m}^{-3}\text{K}^{-1}$.

If the application range of the density measuring transducer is limited to aqueous liquids and water-containing mixtures, the factor to be multiplied by the maximum permissible error can be increased to $0,5 \text{ }^{\circ}\text{C} \times \text{kg}^{-1} \times \text{m}^3$.

6.3.1.2 Testing shall be performed by comparing the temperature determined by the built-in temperature sensor with the actual liquid temperature at three different temperatures, i.e. approximately the lower, upper and mean value (preferably 20 °C) of the specified liquid temperature range. Ambient temperature shall be kept constant to within $\pm 1 \text{ }^{\circ}\text{C}$ of the mean value for the specified ambient temperature range of the density measuring transducer. For this test

- switch on the density measuring transducer and circulate water, or, if water is not suitable, a typical test liquid, for at least 1 h at a temperature as specified above and at a suitable flow rate;
- determine the actual liquid temperature as the mean value of the temperatures at the inlet and outlet of the density measuring transducer, measured by suitable thermometers;
- calculate the deviation between the actual liquid temperature and the temperature displayed by the density transducer.

The calculated deviations shall not exceed the maximum permissible error specified for the density measuring transducer multiplied by the factor $0,2 \text{ }^{\circ}\text{C} \times \text{m}^3 \times \text{kg}^{-1}$ or $0,5 \text{ }^{\circ}\text{C} \times \text{m}^3 \times \text{kg}^{-1}$ (see 6.3.1.1) at all three temperatures.

6.3.2 Separate temperature transducer

If the processing unit of the density meter (see item 5 in Figure 1) is intended to indicate the liquid temperature measured by an external temperature transducer (see item 6 in Figure 1), its error of measurement shall not exceed the maximum permissible error of the density measuring transducer multiplied by the factor $0,2 \text{ }^{\circ}\text{C} \times \text{m}^3 \times \text{kg}^{-1}$ or $0,5 \text{ }^{\circ}\text{C} \times \text{m}^3 \times \text{kg}^{-1}$ (see 6.3.1.1).

6.4 Display and output of results

6.4.1 Display of results

The display of results shall be designed in such a way that

- the density is displayed in kilogram per cubic metre or gram per cubic centimetre together with the measurement unit;
- the resolution of the density display on a digital scale the values given in Table 1;
- one scale interval on an analogue scale is equal to the maximum permissible error of the process density meter and the spacing of the scale marks is minimum 1 mm.

Table 1 — Resolution and maximum permissible errors

Maximum permissible error kg/m ³	Resolution kg/m ³	Factor
1,0	0,1	1/10
0,5	0,1	1/5
0,20	0,01	1/20
0,10	0,01	1/10

A display may be part of a separate indicating unit comprising a computer or calculator used for the evaluation of the density results.

6.4.2 Additional outputs

Optional displays shall be designed in such a way that

- the oscillation period or frequency is displayed on request and is clearly distinguished from the density display;
- the temperature of the liquid is displayed in degrees Celsius;
- the measurement unit is displayed together with the measurement value;
- the malfunctions are displayed;
- the instrument constants are displayed on request.

Additional instrument data, if available, may be displayed on request.

A visual check shall be performed to ensure that the resolution of the density display complies with the manufacturer's specification in accordance with 9.1.

6.5 Auxiliary units and data transfer

If the density meter consists of several separated units or if additional devices are connected, the data shall be transferred unchanged and unaffected.

Additional devices for showing measured data shall display those unchanged and unaffected.

The interfaces, data transfer and additional units shall be clearly defined and work without susceptibility to interferences, i.e. they shall not influence the data nor cause any malfunctions.

If the interfaces, data transfer and additional units differ from these definitions or are faulty, the output of the measured data shall be clearly recognized as invalid.

6.6 Safety requirements

The safety requirements specified in IEC 61010-1 shall be followed as far as they are applicable to oscillation-type density meters.

Testing shall be performed in accordance with IEC 61010-1.

6.7 Electromagnetic compatibility

If not otherwise required by national or regional standards, the EMC requirements specified in IEC 61326-1 shall be followed, as far as they are applicable to oscillation-type density meters.

Testing shall be in accordance with the above-mentioned standards.

7 Preadjustment and adjustment

7.1 Preadjustment of process density meters

The process density meter shall be preadjusted according to the manufacturer's instructions. Preadjustment is performed by determining and setting the instrument constants (see 3.1 in ISO 15212-1:1998). As a rule, preadjustment is not possible after installation of the density meter in the process environment. It requires special test rigs.

Preadjustment can be performed with air and distilled or de-ionized water and should be performed at the intended operating temperature and operating pressure. The density values of water and of moist air are specified in Tables A.1 and B.1 of ISO 15212-1:1998.

7.2 Preadjustment of density measuring transducers

The density measuring transducer shall be preadjusted in accordance with the manufacturer's instructions. It shall be performed using a suitable processing unit that has been adjusted in accordance with 7.4 and calibrated in accordance with 8.1.4.

Preadjustment can be performed with air and distilled or de-ionized water and should be performed at the intended operating temperature and operating pressure. The density values of water and of moist air are specified respectively in Tables A.1 and B.1 of ISO 15212-1:1998.

7.3 Adjustment of installed density measuring transducers

The adjustment after installation of the density measuring transducer in the process environment shall be performed in accordance with the manufacturer's instructions. The adjustment is performed in order to minimize measurement errors identified during calibration. Adjustment shall be performed using equations, sensor coefficients and temperature, pressure and, where appropriate, sound velocity constants specified for the instrument by the manufacturer.

After each maintenance of the instrument, an adjustment of the density meter shall be performed.

7.4 Adjustment of processing units

Processing units shall be adjusted in accordance with the manufacturer's instructions. Adjustment is performed by determining and setting instrument constants.

A verification of the adjustment can be performed either by using a simulator or by setting fixed values for density measuring transducer signals.

8 Calibration

8.1 Laboratory calibration

8.1.1 Test liquids

To calibrate process density meters in a laboratory environment in accordance with this part of ISO 15212, test liquids shall be used whose densities and, if applicable, viscosities and sound velocities are known to be within the measuring range specified by the manufacturer as well as the working ranges of temperature, pressure and flow.

The density values of the test liquids shall be determined traceable to national standards with an uncertainty of measurement at the 95 % confidence level ($k = 2$) that is not greater than 30 % of the maximum permissible error of the process density meter or of the density measuring transducer to be tested. The density determination of the test liquids shall be performed right after the density values have been recorded from the process density meter under calibration.

Calibrated oscillation-type density meters for laboratory use, hydrometers or pycnometers, for example, are suitable instruments for the density determination of the test liquids.

The test liquids shall be selected with regard to the use of the process density meter, i.e. their properties shall meet the application of the instrument as far as possible.

8.1.2 Calibration apparatus for process density meters

For laboratory calibration of process density meters the calibration apparatus shall be designed in such a way that it is capable of performing correctly under the working conditions of liquid temperature, pressure and flow and measuring the actual values of these working conditions traceable to national standards.

In order to make measurements of various liquid densities, viscosities and sound velocities, the calibration apparatus shall be designed in such a way that various test liquids can be used.

The combined contributions of variations and measurement uncertainties of the achieved working conditions to the total uncertainty of the density meter calibration at the 95 % confidence level ($k = 2$) shall not exceed 30 % of the maximum permissible error of the density meter.

8.1.3 Calibration apparatus for density measuring transducers

Calibration apparatuses for density measuring transducers shall meet the requirements for calibration apparatuses for process density meters (see 8.1.2).

Additionally, it shall contain a programmable processing unit. The instrument characteristics shall fit with those of the density measuring transducer to be calibrated. The uncertainty contribution of this processing unit at the 95 % confidence level ($k = 2$) shall not exceed 10 % of the maximum permissible error of the density measuring transducer to be calibrated.

8.1.4 Calibration apparatus for processing units

Calibration apparatuses for processing units of process density meters shall electrically simulate density measuring transducers.

They shall be capable of generating all relevant output signals of measuring transducers simulating various liquid densities, temperatures, pressures and, where applicable, liquid viscosities, sound velocities and environmental conditions.

Values of generated signals, e.g. frequencies, shall be traceable to national standards. The combined uncertainty of these measurement signals at the 95 % confidence level ($k = 2$) shall not exceed 15 % of the maximum permissible error of density measuring transducers specified in Table 2 (see 9.1).

8.1.5 Laboratory calibration procedure for process density meters

Each calibration is related to the actual set instrument constants. By reason of this, the instrument constants shall be reported with the calibration result. Furthermore, each calibration is related to the selected measuring range, the working ranges of temperature, pressure, and, where applicable, liquid viscosity and sound velocity as well as to the environmental conditions. All relevant parameters influencing the measurement result shall be reported with the calibration result.

Calibrations shall be performed at constant liquid temperatures, liquid pressures, liquid properties and environmental temperatures. The variation of each of these parameters influencing the measurement result shall not exceed the values given in 8.1.2.

For validation of the process density meter accuracy, e.g. according to clause 9, calibration shall be performed at each specified or selected calibration point (see 9.2.1) by the following procedure.

- Install the process density meter in the calibration apparatus, switch on the instrument and, where applicable, select the measuring and working range according to the manufacturer's instructions.
- Set the liquid temperature, the liquid pressure, the liquid flow and, where appropriate, the environmental temperature of the calibration apparatus.
- Wait until all set working conditions and the sensor temperature are stable.
- Take a minimum of 10 consecutive readings of the measured density and the actual working parameters. The time interval between two readings shall be at minimum 60 s.
- From the density readings ρ_i calculate the mean value ρ and the standard deviation s as follows:

$$\rho = \frac{1}{n} \sum_{i=1}^{10} \rho_i \tag{2}$$

$$s = \sqrt{\frac{\sum (\rho_i - \rho)^2}{n - 1}} \tag{3}$$

where n is the total number of readings and i the counting index.

- Calculate the systematic error of measurement $\Delta\rho$ as the difference between the mean density ρ and known reference density ρ_{ref} of the test liquid used at the particular working conditions of temperature and pressure.

$$\Delta\rho = \rho - \rho_{ref} \tag{4}$$

- Calculate the uncertainty of measurement at the 95 % confidence level ($k = 2$) from the uncertainty contributions of the calibration apparatus used, the uncertainty contributions of the liquid density and, if applicable, of other liquid properties and from the above calculated standard deviations in accordance with the *Guide to the expression of uncertainty in measurement (GUM)*.

List the calibration results in a table containing each of the following parameters in adjacent columns:

- the reference density of the liquid;
- the systematic error of measurement;
- the uncertainty of measurement;
- other parameters influencing the calibration;
- the set instrument constants.

8.1.6 Laboratory calibration procedure for density-measuring transducers

The calibration of density-measuring transducers shall be performed like the calibration of process density meters (see 8.1.5) using the calibration apparatus in accordance with 8.1.3.

When calculating the uncertainty of measurement, the uncertainty contribution of the processing unit in accordance with 8.1.4 shall also be taken into account.

8.1.7 Laboratory calibration procedure for processing units

Processing units shall be calibrated in accordance with the manufacturer's instructions using a calibration apparatus in accordance with 8.1.4.

Each calibration is related to the actual set instrument constants and to the actual working parameters simulated by the calibration apparatus. The set instrument constants and the measured values of all simulated working parameters shall be reported with the calibration result.

If a processing unit can process and display also other parameters than density, such as temperature and pressure, the calibration of these separate measurement circuits shall be part of the calibration.

When calibrating a processing unit, a minimum of 10 readings shall be taken at each specified or selected calibration point (see 9.2.1).

The evaluation of the readings of each measured parameter shall be performed by the following procedure.

- From the readings x_i , calculate the mean value x and the standard deviation s using Equations (2) and (3) given in 8.1.5.
- Calculate the systematic error of measurement Δx of each measured parameter as the difference between the mean values x and the known reference values x_{ref} provided by the apparatus in accordance with 8.1.4 using Equation (4) in 8.1.5.
- Calculate the uncertainty of measurement of each calibrated measurement circuit at the 95 % confidence level ($k = 2$) from the uncertainty contributions of the calibration apparatus used and from the standard deviation s .
- List the calibration results in tabular form (see 8.1.5).

8.2 In-situ calibration

8.2.1 Liquid

Calibration of installed process density meters and density measuring transducers can be performed by only using the process liquid.

The density of the process liquid shall be determined traceable to national standards conforming to the method given in 8.1.1 for laboratory calibration.

If necessary, the influence of temperature and pressure to the density of the liquid shall be considered. Therefore, the liquid temperature shall be measured with a deviation to the actual liquid temperature as given in 6.2. The pressure shall be measured with a deviation to the actual pressure in the liquid not greater than the maximum permissible error of the density measuring transducer multiplied by the factor of $0,2 \text{ MPa} \times \text{kg}^{-1} \times \text{m}^3$ ($2 \text{ bar} \times \text{kg}^{-1} \times \text{m}^3$).

NOTE For the definition of this factor a maximum pressure density deviation of $3 \text{ kg} \times \text{m}^3 \times \text{MPa}^{-1}$ ($0,3 \text{ kg} \times \text{m}^3 \times \text{bar}^{-1}$) has been assumed.

8.2.2 Apparatus

Pressure pycnometers are particularly suitable for traceable measurements of the liquid density under temperature and pressure conditions existing in the process.

To calibrate installed density meters or density measuring transducers, an installation shall exist to take liquid samples from the process.

If only density measuring transducers are to be calibrated, a programmable processing unit shall be used as described in 8.1.3.

If only processing units are to be calibrated, electrical simulators shall be used as specified in 8.1.4.

8.2.3 *In-situ* calibration procedure for process density meters

Each calibration is related to the actual set instrument constants which shall be reported with the calibration result.

Furthermore, each calibration is related to process parameters such as temperature, pressure, liquid flow, and, where applicable, liquid viscosity and sound velocity as well as to the environmental conditions. Therefore, all parameters influencing the result of measurement shall be reported with the calibration result.

Calibration shall be performed at constant liquid temperature, liquid pressure, liquid properties and environmental temperature. If the process allows, the variation of these parameters shall not exceed the values given in 8.1.2.

In-situ calibration of the process density meter shall be performed by the following procedure.

- Switch on the density meter according to the manufacturer's instructions.
- Wait until the process parameters, such as liquid temperature, liquid pressure, liquid flow as well as sensor temperature and environmental conditions are stable.
- Take a sample from the process liquid and measure the liquid density with a suitable calibrated density measuring instrument (see 8.2.2). The influence of the liquid temperature and the liquid pressure shall be considered (see 8.2.1).
- Take three consecutive readings of the measured density and the actual working parameters. For an acceptable calibration, at least two of the three readings shall not exceed the maximum permissible error specified by the manufacturer or as specified in Table 2.

List the calibration results in a table containing each of the following parameters in adjacent columns:

- the reference density of the process liquid;
- the systematic error of each of the three measurements;
- the uncertainty of measurement;
- the set instrument constants;
- the relevant process parameters.

8.2.4 *In-situ* calibration procedure for density measuring transducers

If a density measuring transducer is to be calibrated *in-situ*, the calibration shall be performed in accordance with 8.2.3.

8.2.5 *In-situ* calibration procedure for processing units

If a processing unit is to be calibrated *in-situ*, the calibration shall be performed in accordance with 8.1.7.

9 Process density meter accuracy

9.1 Accuracy requirements

The maximum permissible error of the adjusted density meter shall be $\pm 1 \text{ kg/m}^3$ in the measuring range specified by the manufacturer. If lower values are specified by the manufacturer, these shall correspond to the values given in Table 1 and Table 2.

For functional units of process components of density meters the following values shall apply in the measuring range specified by the manufacturer:

- a) density measuring transducer: $\pm 0,8 \text{ kg/m}^3$;
- b) processing unit: $\pm 0,2 \text{ kg/m}^3$.

If lower values are specified by the manufacturer, these shall correspond to the values given in Table 2. If complete process density meters (see 4.2) are tested and/or supplied, the maximum permissible errors given in Table 2 for functional units do not apply.

Table 2 — Maximum permissible errors of process density meters and of functional units

Values in kilograms per cubic metre, kg/m^3

Density meter	Density measuring transducer	Processing unit
1,0	0,8	0,2
0,5	0,4	0,1
0,20	0,15	0,05
0,10	0,08	0,02

9.2 Laboratory conformity test

9.2.1 Process density meters and density measuring transducers

Process density meters and density measuring transducers shall be tested with at least three different low-viscosity test liquids whose densities are distributed approximately uniformly over the measuring range of the instrument to be tested.

Process density meters and density measuring transducers shall be tested with each test liquid at least at three temperatures, namely at the lower and upper ends and in the middle of the specified temperature working range.

If the process density meter or the density measuring transducer to be tested is designed for use at different pressures, tests under at least the following temperature and pressure conditions shall be performed with each test liquid:

- a) at a temperature and at a pressure of the liquid whose values lie approximately in the middle of the respective working ranges specified,
- b) at a temperature and at a pressure of the liquid whose values lie at the upper end of the respective working ranges specified,
- c) at a temperature of the liquid which lies at the lower end of the specified temperature range and at a pressure of the liquid specified in a), and
- d) at a temperature of the liquid in a) and at a pressure of the liquid at the lower end of the specified pressure working range.

As far as applicable, the temperature of $20 \text{ }^\circ\text{C}$ and the pressure of $101,3 \text{ kPa}$ shall be used as preferential conditions for the above-mentioned middle or the lower end of the temperature and pressure working ranges.

The tests shall be performed at a flow rate of the test liquid through the density measuring transducer which lies in the middle of the specified flow rate range.

If the flow rate through the density measuring transducer is expected to influence the density values displayed or recorded, at least the following additional tests shall be performed with one of the three test liquids and under the temperature and pressure conditions specified in a):

- e) at a flow rate which lies at the lower end of the specified flow rate range, and
- f) at a flow rate which lies at the upper end of the specified flow rate range.

If the liquid's viscosity and/or velocity of sound effect (vos effect) is expected to influence the density values displayed or recorded, tests shall be performed with at least two other test liquids of known but clearly different viscosities or vos effects and under the temperature and pressure conditions specified in a).

9.2.2 Processing units

Processing units shall be tested at the lower and upper ends as well as in the middle of the specified density measuring range.

If the processing unit processes additional parameters, such as temperature, pressure and/or viscosity, the correctness of processing shall be tested for at least two working parameters.

9.3 *In-situ* tests

The calibration points for installed process density meters and density measuring transducers are given by the working parameters of the process (temperature, pressure, flow rate and process liquid) and cannot in general be varied.

By reason of this, only a test at one working parameter shall be performed.

If a working parameter can be varied without the process being significantly impaired, the test shall be performed at at least two appropriate calibration points.

9.4 Test procedure and conformity assessment

9.4.1 Test procedure

The test for conformance with the accuracy requirements shall be performed in two steps:

- a) by calibrating the process density meter or the functional units in accordance with 8.1;
- b) by comparing the systematic errors of measurement, determined in accordance with 8.1.5, with the corresponding maximum permissible errors specified in 9.1.

9.4.2 Conformity assessment

The systematic errors of measurement determined at any calibration point shall not exceed the maximum permissible error specified by the manufacturer or specified in Table 2.

The uncertainty of measurement at the 95 % confidence level ($k = 2$), determined in accordance with 8.1.5, shall not be taken into account if it is smaller than or equal to one third of the specified maximum permissible error (so-called shared risk concept).

If the uncertainty of measurement exceeds the value of one third of the specified maximum permissible error, the systematic errors of measurement determined, expanded by the uncertainty at the 95 % confidence level ($k = 2$), shall not exceed at any calibration point the maximum permissible error specified by the manufacturer or specified in Table 2.

10 Installation

The installation of process density meters in the process environment shall be performed in accordance with the manufacturer's instructions. Special attention shall be given to:

- pipe stresses and vibration;
- gas bubbles;
- flow rate and flow direction;
- transducer orientation in the liquid flow;
- temperature stability;
- pressure drop.

The manufacturer shall provide detailed information on these items in his installation instructions (see clause 11).

If a separate temperature transducer is applied, its manufacturer shall provide information on the installation position; the measured temperature of the liquid shall represent the actual temperature of the liquid in the density-measuring transducer (see 6.2.3).

11 Operating manual

Each process density meter shall be accompanied by an operating manual containing sufficient information that a competent operator can adjust, calibrate and use the process density meter correctly without recourse to other assistance.

It shall contain complete information on at least the following:

- transport and storage requirements;
- installation instructions, covering at least the items specified in clause 10;
- operation and maintenance;
- maintenance interval with respect to specific applications;
- safety rules for using the density meter;
- adjustment;
- measurement of the liquid density;
- measurement of the liquid temperature;
- working ranges of density, temperature, viscosity, pressure, and flow;
- sensor coefficients, for example calibration and temperature constants;
- maximum permissible errors, resolution, repeatability (in terms of standard deviation);
- cleaning and suitable cleaning solutions;
- avoidance of operation and measurement errors;
- permissible environmental conditions;
- hints to permissible vibrations;
- error messages.

On request, the manufacturer shall provide certificates about sensor materials.

12 Marking

The density meter shall be clearly labelled with the following information:

- a) name or mark of the manufacturer or supplier;
- b) type or model designation;
- c) individual instrument or serial number.

.....

www.iso.org/standard/62244.html

ICS 17.060

Price based on 16 pages

© ISO 2002 – All rights reserved