**Workplace air — Determination of metals
and metalloids in airborne particulate
matter by inductively coupled plasma
atomic emission spectrometry —**

**Part 2:
Sample preparation**

*Air des lieux de travail — Détermination des métaux et métalloïdes
dans les particules en suspension dans l'air par spectrométrie
d'émission atomique avec plasma à couplage inductif —*

Partie 2: Préparation des échantillons





COPYRIGHT PROTECTED DOCUMENT

© ISO 2012

All rights reserved. Unless otherwise specified, no part of this publication may be reproduced or utilized in any form or by any means, electronic or mechanical, including photocopying and microfilm, without permission in writing from either ISO at the address below or ISO's member body in the country of the requester.

ISO copyright office
Case postale 56 • CH-1211 Geneva 20
Tel. + 41 22 749 01 11
Fax + 41 22 749 09 47
E-mail copyright@iso.org
Web www.iso.org

Published in Switzerland

Contents

Page

Foreword	iv
Introduction	v
1 Scope	1
2 Normative references	2
3 Terms and definitions	2
4 Principle	4
5 Requirements	4
6 Reactions	4
7 Reagents	5
8 Laboratory apparatus	5
9 Procedure	6
9.1 Soluble metal and metalloid compounds	6
9.2 Total metals and metalloids and their compounds	6
9.3 Mixed exposure	6
10 Special cases	7
10.1 Action to be taken if there is doubt about the effectiveness of the selected sample dissolution method	7
10.2 Action to be taken when particles have become dislodged from the filter during transportation	7
10.3 Action to be taken regarding sampler wall deposits	7
11 Laboratory records	7
Annex A (informative) Safety precautions to be observed when using hydrofluoric and perchloric acids	8
Annex B (normative) Sample dissolution method for soluble metal and metalloid compounds	9
Annex C (normative) Sample dissolution using nitric acid and hydrochloric acid on a hotplate	15
Annex D (normative) Sample dissolution using hydrofluoric and nitric acids and ultrasonic agitation	19
Annex E (normative) Sample dissolution using sulfuric acid and hydrogen peroxide on a hotplate	22
Annex F (normative) Sample dissolution using nitric acid and perchloric acid on a hotplate	26
Annex G (normative) Sample dissolution in a closed vessel microwave dissolution system	30
Annex H (normative) Sample dissolution at 95 °C using a hot block	35
Annex I (normative) Action to be taken when there is visible, undissolved, particulate material after sample dissolution	38
Annex J (informative) Sampler wall deposits	43
Bibliography	45

Foreword

ISO (the International Organization for Standardization) is a worldwide federation of national standards bodies (ISO member bodies). The work of preparing International Standards is normally carried out through ISO technical committees. Each member body interested in a subject for which a technical committee has been established has the right to be represented on that committee. International organizations, governmental and non-governmental, in liaison with ISO, also take part in the work. ISO collaborates closely with the International Electrotechnical Commission (IEC) on all matters of electrotechnical standardization.

International Standards are drafted in accordance with the rules given in the ISO/IEC Directives, Part 2.

The main task of technical committees is to prepare International Standards. Draft International Standards adopted by the technical committees are circulated to the member bodies for voting. Publication as an International Standard requires approval by at least 75 % of the member bodies casting a vote.

Attention is drawn to the possibility that some of the elements of this document may be the subject of patent rights. ISO shall not be held responsible for identifying any or all such patent rights.

ISO 15202-2 was prepared by Technical Committee ISO/TC 146, *Air quality*, Subcommittee SC 2, *Workplace atmospheres*.

This second edition cancels and replaces the first edition (ISO 15202-2:2001), which has been technically revised. The major changes in the second edition are as follows.

- Definitions have been updated.
- In Annex B, use of ammonium citrate leach solution has been eliminated.
- A new Annex H has been added to provide a method for sample dissolution using a 95 °C hot block dissolution system. The original Annex H is now Annex I.
- A new Annex J has been added to provide guidance regarding sampler wall deposits.

Annexes B through I form a normative part of this document. Annex A and Annex J are for information only.

ISO 15202 consists of the following parts, under the general title *Workplace air — Determination of metals and metalloids in airborne particulate matter by inductively coupled plasma atomic emission spectrometry*:

- *Part 1: Sampling*
- *Part 2: Sample preparation*
- *Part 3: Analysis*

Introduction

The health of workers in many industries is at risk through exposure by inhalation of toxic metals and metalloids. Industrial hygienists and other public health professionals need to determine the effectiveness of measures taken to control workers' exposure, and this is generally achieved by making workplace air measurements. This part of ISO 15202 has been published in order to make available a method for making valid exposure measurements for a wide range of metals and metalloids in use in industry. It will be of benefit to agencies concerned with health and safety at work, industrial hygienists and other public health professionals, analytical laboratories, industrial users of metals and metalloids and their workers.

ISO 15202, published in three parts, specifies a generic method for the determination of the mass concentration of metals and metalloids in workplace air using inductively coupled plasma atomic emission spectrometry (ICP-AES).

- ISO 15202-1 gives details of relevant International, European and National Standards which specify characteristics, performance requirements and test methods relating to sampling equipment. It also augments guidance provided elsewhere on assessment strategy and measurement strategy, as well as specifying a method for collecting samples of airborne particulate matter for subsequent chemical analysis.
- ISO 15202-2 (i.e. this part) describes a number of procedures for preparing sample solutions for analysis by ICP-AES.
- ISO 15202-3 gives requirements and test methods for the analysis of sample solutions by ICP-AES.

The sample preparation methods described in this part of ISO 15202 are generally suitable for use with analytical techniques other than ICP-AES; e.g. atomic absorption spectroscopy (AAS) and inductively coupled plasma mass spectrometry (ICP-MS).

It has been assumed in the drafting of this part of ISO 15202 that the execution of its provisions and the interpretation of the results obtained are entrusted to appropriately qualified and experienced people.

Workplace air — Determination of metals and metalloids in airborne particulate matter by inductively coupled plasma atomic emission spectrometry —

Part 2: Sample preparation

WARNING — The use of this part of ISO 15202 may involve hazardous materials, operations and equipment. This part of ISO 15202 does not purport to address any safety problems associated with its use. It is the responsibility of the user of this part of ISO 15202 to establish appropriate safety and health practices and determine the applicability of regulatory limitations prior to use.

1 Scope

1.1 This part of ISO 15202 specifies a number of suitable methods for preparing test solutions from samples of airborne particulate matter collected using the method specified in ISO 15202-1, for subsequent determination of metals and metalloids by ICP-AES using the method specified in ISO 15202-3. It contains information about the applicability of the methods with respect to the measurement of metals and metalloids for which limit values have been set. The methods can also be used in the measurement of some metals and metalloids for which limit values have not been set but no information about its applicability is provided in this case.

NOTE The sample preparation methods described in this part of ISO 15202 are generally suitable for use with analytical techniques other than ICP-AES, e.g. atomic absorption spectrometry (AAS) by ISO 8518^[5] and ISO 11174^[10] and inductively coupled plasma mass spectrometry (ICP-MS) by ISO 30011^[11].

1.2 The method specified in Annex B is applicable when making measurements for comparison with limit values for soluble metal or metalloid compounds.

1.3 One or more of the sample dissolution methods specified in Annexes C through H are applicable when making measurements for comparison with limit values for total metals and metalloids and their compounds. Information on the applicability of individual methods is given in the scope of the annex in which the method is specified.

1.4 The following is a non-exclusive list of metals and metalloids for which limit values have been set (see References [15] and [16]) and for which one or more of the sample dissolution methods specified in this part of ISO 15202 are applicable. However, there is no information available on the effectiveness of any of the specified sample dissolution methods for those elements in italics.

ISO 15202-2:2012(E)

Aluminium	Calcium	Magnesium	Selenium	Tungsten
Antimony	Chromium	Manganese	Silver	<i>Uranium</i>
Arsenic	Cobalt	Mercury	Sodium	Vanadium
Barium	Copper	Molybdenum	Strontium	Yttrium
Beryllium	<i>Hafnium</i>	Nickel	<i>Tantalum</i>	Zinc
Bismuth	<i>Indium</i>	Phosphorus	Tellurium	Zirconium
Boron	Iron	<i>Platinum</i>	Thallium	
Caesium	Lead	Potassium	Tin	
Cadmium	Lithium	<i>Rhodium</i>	Titanium	

ISO 15202 is not applicable to the determination of elemental mercury or arsenic trioxide, since mercury vapour and arsenic trioxide vapour are not collected using the sampling method specified in ISO 15202-1.

2 Normative references

The following referenced documents are indispensable for the application of this document. For dated references, only the edition cited applies. For undated references, the latest edition of the referenced document (including any amendments) applies.

ISO 15202-1, *Workplace air — Determination of metals and metalloids in airborne particulate matter by inductively coupled plasma atomic emission spectrometry — Part 1: Sampling*

ISO 15202-3, *Workplace air — Determination of metals and metalloids in airborne particulate matter by inductively coupled plasma atomic emission spectrometry — Part 3: Analysis*

EN 13890, *Workplace exposure — Procedures for measuring metals and metalloids in airborne particles — Requirements and test methods*

3 Terms and definitions

For the purposes of this part of ISO 15202, the following terms and definitions apply.

3.1 analysis
all operations carried out after sample preparation to determine the amount or concentration of the analyte(s) of interest present in the sample

NOTE Adapted from EN 14902:2005^[14], 3.1.1.

3.2 analytical recovery
ratio of the mass of analyte measured in a sample to the known mass of analyte in that sample

NOTE The analytical recovery is usually given as a percentage.

[EN 1540:2011^[13]]

3.3**chemical agent**

any chemical element or compound, on its own or admixed as it occurs in the natural state or as produced, used, or released including release as waste, by any work activity, whether or not produced intentionally and whether or not placed on the market

[Council Directive 98/24/EC^[17], Art. 2(a)]

3.4**exposure by inhalation**

situation in which a chemical agent is present in the air that is inhaled by a person

NOTE Adapted from EN 1540:2011^[13].

3.5**occupational exposure limit value
limit value**

limit of the time-weighted average of the concentration of a chemical agent in the air within the breathing zone of a worker in relation to a specified reference period

[Council Directive 98/24/EC^[17], Art. 2(d)]

EXAMPLES Threshold Limit Values[®] (TLVs) established by the ACGIH^[15] and Indicative Occupational Exposure Limit Values (IOELVs) promulgated by the European Commission (Council Directive 2006/15/EC^[16]).

3.6**measuring procedure
measurement procedure**

set of operations, described specifically, for the sampling and analysis of chemical agents in air

NOTE 1 A measuring procedure for the sampling and analysis of chemical agents in air usually includes the following steps: preparation for sampling, sampling, transportation and storage, preparation of samples for analysis and analysis.

NOTE 2 Adapted from EN 1540:2011^[13].

3.7**air sampler
sampler**

device for separating chemical agents from the surrounding air

NOTE 1 Air samplers are generally designed for a particular purpose, e.g. for sampling gases and vapours or for sampling airborne particles.

NOTE 2 Adapted from EN 1540:2011^[13].

3.8**sample dissolution**

process of obtaining a solution containing all analytes of interest from a sample, which might or might not involve complete dissolution of the sample

3.9**sample preparation**

all operations carried out on a sample, usually after transportation and storage, to prepare it for analysis, including transformation of the sample into a measurable state, where necessary

NOTE Adapted from EN 14902:2005^[14], 3.1.24.

3.10**sample solution**

solution prepared from a sample by the process of sample dissolution

NOTE 1 A sample solution might need to be subjected to further operations, e.g. dilution, or addition, or both, of an internal standard(s), in order to produce a test solution.

ISO 15202-2:2012(E)

NOTE 2 Adapted from EN 14902:2005^[14], 3.1.22.

3.11

test solution

blank solution or sample solution that has been subjected to all operations required to bring it into a state in which it is ready for analysis

NOTE 1 “Ready for analysis” includes any required dilution or addition, or both, of an internal standard. If a blank solution or sample solution is not subject to any further operations before analysis, it is a test solution.

NOTE 2 Adapted from EN 14902:2005^[14], 3.1.30.

3.12

workplace

designated area or areas in which the work activities are carried out

[EN 1540:2011^[13]]

4 Principle

4.1 Airborne particles containing metals and metalloids are collected by drawing a measured volume of air through a filter mounted in a sampler designed to collect an appropriate size fraction of airborne particles, using the method specified in ISO 15202-1.

4.2 An appropriate and suitable sample dissolution method is selected from those specified in Annexes B through H, taking into consideration the metals and metalloids which are to be determined, the limit values that have been set for those metals and metalloids, the applicability of the methods for dissolution of the metals and metalloids of interest from materials which could be present in the test atmosphere and the availability of the required laboratory apparatus.

4.3 The filter and collected sample are then treated to dissolve the metals and metalloids of interest using the selected sample dissolution method.

4.4 The resultant test solution is subsequently analysed for the metals and metalloids of interest by inductively coupled plasma-atomic emission spectrometry using the method specified in ISO 15202-3.

NOTE Sample preparation methods described in Annexes B through H of this part of ISO 15202 are generally suitable for use with analytical techniques other than ICP-AES, e.g. AAS by ISO 8518^[5] and ISO 11174^[10] and ICP-MS by ISO 30011^[11]. For ICP-MS, changes might be required in the concentrations of acids or the dilution factors used to prepare test solutions. Furthermore, some acids, such as hydrochloric acid, are not recommended for test solutions for analysis by ICP-MS.

5 Requirements

The measuring procedure as a whole (covered by ISO 15202-1, ISO 15202-2 and ISO 15202-3) shall comply with any relevant International, European or National Standards that specify performance requirements for measuring chemical agents in workplace air (for example EN 482^[12] and EN 13890).

6 Reactions

In general, the majority of particulate metals and metalloids and particulate metal and metalloid compounds which are commonly of interest in samples of workplace air are converted to water-soluble ions by one or more of the sample dissolution methods specified in this part of ISO 15202. However, if there is any doubt about whether a method will exhibit the required analytical recovery for a particular application, it is necessary to investigate this before proceeding with the method (see 10.1).

7 Reagents

During the analysis, use only reagents of analytical grade and only water as specified in 7.1.

NOTE 1 Details of reagents that are required for use in Annexes B through I are given in the annex concerned.

NOTE 2 It might be necessary to use acids of higher purity in order to obtain an adequate detection limit for some metals and metalloids.

7.1 Water, complying with the requirements for ISO 3696^[3] grade 2 water (electrical conductivity less than 0,1 mS/m and resistivity greater than 0,01 MΩ·m at 25 °C).

It is recommended that the water used be obtained from a water purification system that delivers ultrapure water having a resistivity greater than 0,18 MΩ·m (usually expressed by manufacturers of water purification systems as 18 MΩ·cm).

7.2 Nitric acid (HNO₃), concentrated, $\rho_{\text{HNO}_3} \approx 1,42 \text{ g ml}^{-1}$, $w_{\text{HNO}_3} \approx 70 \%$ mass fraction.

The concentration of the metals and metalloids of interest shall be less than 0,1 µg ml⁻¹.

WARNING — Concentrated nitric acid is corrosive and oxidizing, and nitric acid fumes are irritant. Avoid exposure by contact with the skin or eyes, or by inhalation of fumes. Use suitable personal protective equipment (including suitable gloves, face shield or safety spectacles, etc.) when working with the concentrated or dilute nitric acid and carry out sample dissolution with concentrated nitric acid in open vessels in a fume hood.

7.3 Nitric acid, diluted 1 + 9.

Carefully and slowly begin adding 50 ml of concentrated nitric acid (7.2) to 450 ml of water (7.1) in a 1 l polypropylene bottle (8.5). Add the acid in small aliquots. Between additions, swirl to mix and run cold tap water over the side of the bottle to cool the contents. Do not allow the tap water to contaminate the contents of the bottle. When the addition of the concentrated nitric acid is complete, swirl the bottle to mix the contents, allow to cool to room temperature, close the bottle with its screw cap and mix thoroughly.

8 Laboratory apparatus

NOTE Details of laboratory apparatus that are required for use in Annexes B through I are given in the annex concerned.

Usual laboratory apparatus and, in particular, the following.

8.1 Disposable gloves, impermeable and powder-free, to avoid the possibility of contamination from the hands and to protect them from contact with toxic and corrosive substances. PVC gloves are suitable.

8.2 Glassware, beakers and one-mark volumetric flasks complying with the requirements of ISO 1042^[1], made of borosilicate glass 3.3 complying with the requirements of ISO 3585^[2], cleaned before use by soaking in 1 + 9 nitric acid (7.3) for at least 24 h and then rinsing thoroughly with water (7.1).

Alternatively, the glassware may be cleaned with a suitable laboratory detergent using a laboratory washing machine.

8.3 Flat-tipped forceps, non-metallic (e.g. plastic or plastic-coated), for unloading filters from samplers or from filter transport cassettes.

8.4 Piston-operated volumetric instruments, complying with the requirements of ISO 8655-1^[6] and tested in accordance with ISO 8655-6^[9], including **pipettors** complying with the requirements of ISO 8655-2^[7] and **dispensers** complying with the requirements of ISO 8655-5^[8], for dispensing leach solution, acids, etc.

8.5 Polypropylene bottle, 1 l capacity, with leakproof screw cap.

A bottle made of an alternative plastic may be used provided that it is suitable for the intended use (see 7.3).

9 Procedure

9.1 Soluble metal and metalloid compounds

9.1.1 If results are required for comparison with limit values for soluble metal or metalloid compounds, or both, use the sample dissolution method specified in Annex B to prepare test solutions for analysis by the method specified in ISO 15202-3.

9.1.2 Alternatively, if it is known that no insoluble compounds of the metals or metalloids, or both, of interest are used in the workplace and that none are produced in the processes carried out, prepare test solutions for analysis by the method specified in ISO 15202-3, using one of the sample dissolution methods for total metals and metalloids and their compounds prescribed in Annexes C through H, and compare the results with the limit value for the soluble metals or metalloids, or both, concerned.

The methods prescribed in Annexes C through H are not specific for soluble metal or metalloid compounds, or both. However, in the circumstances described above, they may be used as an alternative to the method described in Annex B, if this is more convenient.

9.2 Total metals and metalloids and their compounds

9.2.1 If results are required for comparison with limit values for total metals or metalloids, or both, and their compounds, select a suitable sample dissolution method from those specified in Annexes C through H. Take into consideration the applicability of each method for dissolution of the metals and metalloids of interest from materials that could be present in the test atmosphere (refer to the clause on the effectiveness of the sample dissolution method in the annex in which the method is specified) and the availability of the required laboratory apparatus.

9.2.2 Use the selected sample dissolution method to prepare test solutions for analysis of total metals and metalloids and their compounds by the method specified in ISO 15202-3.

9.3 Mixed exposure

9.3.1 If results are required

- for comparison with limit values for soluble metal and/or metalloid compounds **and** with limit values for metals and/or metalloids and their insoluble compounds, or
- for comparison with limit values for soluble metal and/or metalloid compounds **and** with limit values for total metals and/or metalloids and their compounds,

follow the instructions given in 9.3.2 and 9.3.3.

9.3.2 Use the sample dissolution method specified in Annex B to prepare test solutions for the determination of soluble metal and metalloid compounds by the method specified in ISO 15202-3.

9.3.3 Select a suitable sample dissolution method for total metals and metalloids and compounds (see 9.2). Use this to treat undissolved material from the method for soluble metal and metalloid compounds (see B.6.6.1) and prepare test solutions for determination of metals and metalloids and their insoluble compounds by the method specified in ISO 15202-3.

10 Special cases

10.1 Action to be taken if there is doubt about the effectiveness of the selected sample dissolution method

10.1.1 If there is any doubt about whether the selected sample dissolution method will exhibit the required analytical recovery when used for dissolution of the metals and metalloids of interest from materials which could be present in the test atmosphere, determine its effectiveness for that particular application. For total metals and metalloids, this may be achieved by analysing a bulk sample of known composition which is similar in nature to the materials being used or produced in the workplace, e.g. a certified reference material. For soluble metals and metalloids, analytical recovery is best determined by analysing filters spiked with solution containing a known mass of the soluble compound of interest.

NOTE In designing an experiment to determine the effectiveness of a sample dissolution method, it should be recognized that the particle size of a bulk sample could have a significant influence on the efficiency of its dissolution. Furthermore, microgram amounts of relatively insoluble material are normally much more easily dissolved than milligram amounts.

10.1.2 If the analytical recovery is less than the minimum acceptable value prescribed in EN 13890 (analytical recovery at least 90 % with a coefficient of variation less than 5 %), investigate the use of an alternative sample dissolution method. This may be a method not specified in this part of ISO 15202 if it can be demonstrated that its analytical recovery meets the requirements of EN 13890.

10.1.3 Do not use a correction factor to compensate for an apparently ineffective sample dissolution method, since this might equally lead to erroneous results.

10.2 Action to be taken when particles have become dislodged from the filter during transportation

When the filter transport cassettes or samplers are opened, it is advisable to look for evidence that particles have become dislodged from the filter during transportation. If this appears to have occurred, wash the internal surfaces of the filter transport cassette or sampler in the sample dissolution vessel in order to recover the material concerned. Before analysis is carried out, inform the originator of the sample of the condition in which it was received so that the originator can make a judgement as to whether it is to be analysed.

10.3 Action to be taken regarding sampler wall deposits

Prior to opening filter transport cassettes or samplers, consider the possibility that particles may have been deposited on the interior walls of the cassette or sampler during the sampling event, and actions that may be required to include such particles in the sample. Additional information is provided in Annex J.

11 Laboratory records

11.1 Record details of all reagent sources (lot numbers) used for sample preparation.

11.2 Record details of laboratory apparatus used for sample preparation, where this is relevant, e.g. the serial number of equipment when there is more than one item of equipment of the same type in the laboratory.

11.3 Record any deviations from the specified methods.

11.4 Record any unusual events or observations during sample preparation.

Annex A (informative)

Safety precautions to be observed when using hydrofluoric and perchloric acids

A.1 Special precautions to be observed when using hydrofluoric acid

A.1.1 Take extreme care when using hydrofluoric acid. Ensure that the nature and seriousness of hydrofluoric acid burns is understood before commencing work with this substance.

NOTE The burning sensation associated with many concentrated acid burns is not immediately apparent on exposure to hydrofluoric acid and might not be felt for several hours. Relatively dilute solutions of hydrofluoric acid can also be absorbed through the skin, with serious effects similar to those resulting from exposure to the concentrated acid.

When using hydrofluoric acid, it is recommended that a pair of disposable gloves is worn underneath suitable rubber gloves to provide added protection for the hands.

A.1.2 Carry hydrofluoric acid burn cream (containing calcium gluconate) at all times while working with hydrofluoric acid and for 24 h afterwards. Apply the cream to any contaminated skin, after washing the affected area with copious amounts of water. Obtain medical advice immediately in case of an accident. Calcium gluconate cream has a limited lifetime and should be replaced prior to its expiration date.

A.2 Special precautions to be observed when using perchloric acid

A.2.1 Perchloric acid forms explosive compounds with organics and with many metal salts. When performing sample dissolution using this acid, ensure that any organic material present is destroyed, e.g. by heating with nitric acid before addition of perchloric acid.

A.2.2 Do not allow perchloric acid solutions containing high concentrations of metal salts to boil dry, as solid perchlorates are shock-sensitive and can explode.

A.2.3 Perform sample dissolution using a special fume cupboard designed for the use of perchloric acid and incorporating a scrubbing system to remove acid vapours from exhaust gases so as to prevent the possibility of potentially explosive material accumulating in ducts.

Annex B (normative)

Sample dissolution method for soluble metal and metalloid compounds

B.1 Scope

B.1.1 This annex specifies a method for the dissolution of soluble metal and metalloid compounds using a suitable leach solution.

B.1.2 The method is applicable in all instances, except when use of a specific leach solution or leach conditions, or both, is prescribed in National Standards or Regulations.

B.1.3 Metals for which limit values for soluble compounds have typically been set (see References [15] and [16]), and for which the sample dissolution method specified in this annex is applicable, are listed below:

Aluminium	Molybdenum	Platinum	Silver	Tungsten
Barium	Nickel	Rhodium	Thallium	Uranium

NOTE 1 The above list is based upon the applicability of the sample dissolution procedure reported in References [18], [19] and [20], with adaptation based on expert judgement. Furthermore, the list is not comprehensive and the procedure will be effective for some metals and metalloids that are not listed.

NOTE 2 The sample dissolution method specified in this annex can also be used for the dissolution of soluble zinc compounds, e.g. for determination of zinc chloride in the presence of zinc oxide in galvanizing fume.

B.2 Effectiveness of the sample dissolution method

B.2.1 Soluble compounds of metals and metalloids are essentially defined by the specific leach solutions and leach conditions used in the measurement methods prescribed for their determination. (This is because, except for compounds that are very soluble or very insoluble in water, solubility can be dependent upon the nature of the leach solution and parameters such as particle size, solute/solvent ratio, pH, temperature, etc.) Consequently, the sample dissolution method, by definition, gives the desired result.

B.2.2 Although the sample dissolution method for soluble compounds prescribed in this part of ISO 15202 is design-based, there are circumstances in which it can give incorrect results. In particular, this can occur if a soluble compound reacts with the filter material, or a contaminant on the filter, to produce an insoluble compound. For example, a low recovery will be obtained for soluble silver compounds if the filter used is contaminated with chloride. It is therefore important that proper consideration is given to chemical compatibility when selecting a filter for collecting samples of soluble compounds (see ISO 15202-1). If it is believed that there could be a chemical compatibility problem, tests should be performed to confirm that analytical recovery is satisfactory before samples are collected (see 10.1.1). Low recoveries for soluble silver can also occur if samples are exposed to light^[21].

B.3 Principle

B.3.1 Soluble metal and metalloid compounds are dissolved by treating the filter and collected sample with a suitable leach solution and agitating in a water bath at $37\text{ °C} \pm 2\text{ °C}$ for 60 min.

B.3.2 The resultant sample solution is filtered through a membrane filter to remove undissolved particulate material and to produce a test solution for analysis using the method specified in ISO 15202-3.

B.4 Reagents

B.4.1 Water, as specified in 7.1.

B.4.2 Nitric acid (HNO₃), concentrated, as specified in 7.2.

B.5 Laboratory apparatus

Usual laboratory apparatus and in particular the following.

B.5.1 Disposable gloves, as specified in 8.1.

B.5.2 Glassware, as specified in 8.2.

B.5.2.1 Beakers, 50 ml capacity, of a form that is compatible with filters of the diameter used in the sampler, for preparation of test solutions.

NOTE Beakers are not required if the leach step is carried out in the sampler (see Note 2 in B.6.2.2).

It is preferable to reserve a set of beakers for use in the sample dissolution methods specified in this annex and other annexes of this part of ISO 15202. Heavily contaminated beakers in general usage might not be satisfactorily cleaned by the method specified in 8.2. If such beakers are to be used, it is strongly recommended that they are cleaned under the test conditions before use. This should be done by adding the appropriate reagents and taking through the sample dissolution method concerned.

B.5.2.2 One-mark volumetric flasks, 10 ml capacity for preparation of test solutions.

NOTE 10 ml volumetric flasks are not required if test solutions are to be made up in graduated test tubes (see B.6.3.4) or if undissolved material is to be removed using a syringe filter (see B.6.4).

B.5.3 Disposable test tubes, polypropylene, graduated, 10 ml capacity, with push-fit closures and preferably compatible with the auto sampler tube racks of the ICP-AES instrument.

NOTE Test tubes without graduation are satisfactory if the samples are made up in volumetric flasks (see B.6.3.4).

B.5.4 Forceps, as specified in 8.3.

B.5.5 Piston operated volumetric apparatus, as specified in 8.4, for dispensing leach solution (see B.6.2.2, B.6.3.2, B.6.3.3, B.6.4.1 and B.6.4.2).

B.5.6 Water bath, with temperature control, and preferably equipped with integral sample shaker.

If the water bath is not fitted with an integral sample shaker, a waterproof magnetic stirrer may be placed in the bottom of the water bath and the sample solutions stirred using polypropylene encapsulated magnetic followers.

B.5.7 Suction filtration equipment.

NOTE Suction filtration equipment is not required if disposable syringe filters are used to remove undissolved particulate from the sample solutions (see B.6.4).

B.5.7.1 Suction filtration apparatus, typically a water-operated or electrically driven vacuum pump, connected to a conical flask fitted with a filter funnel/support assembly (see Figure B.1).

NOTE Alternative suction filtration apparatus is commercially available that permits simultaneous vacuum filtration of multiple sample solutions.

B.5.7.2 Membrane filters, of a diameter suitable for use with the suction filtration apparatus (B.5.7.1).

The membrane filters used should be selected carefully, taking full account of any possible reaction of the analyte with the filter material or contaminant of the filter (see B.2.2). Consideration should also be given to the fact that the filters used should preferably be soluble in any subsequent sample preparation method for determination of total metals and metalloids.

B.5.8 Syringe filtration equipment

B.5.8.1 Syringes, disposable, polypropylene, 5 ml capacity, suitable for use with disposable syringe filters (B.5.8.2).

NOTE Disposable syringes are not required if suction filtration equipment is used to remove undissolved particulate from the sample solutions (see B.6.3).

B.5.8.2 Syringe filters, disposable, polypropylene, incorporating a suitable membrane filter (e.g. polypropylene) with a pore size of 0,8 µm or less, for use with disposable syringes (B.5.8.1).

NOTE Disposable syringe filters are not required if suction filtration equipment is used to remove undissolved particulate from the sample solutions (see B.6.3).

B.6 Procedure

B.6.1 Selection of leach solution

B.6.1.1 Except when national standards or regulations specify otherwise, use water (B.4.1) to leach the sample filter.

B.6.1.2 Follow the instructions given in national standards or regulations, if these prescribe that a specific leach solution or leach conditions, or both, is to be used when measuring the soluble compounds of a particular metal or metalloid.

B.6.2 Preparation of sample solutions

NOTE It is advisable to wear disposable gloves (B.5.1) during sample preparation, for personal protection and in order to avoid the possibility of contamination from the hands.

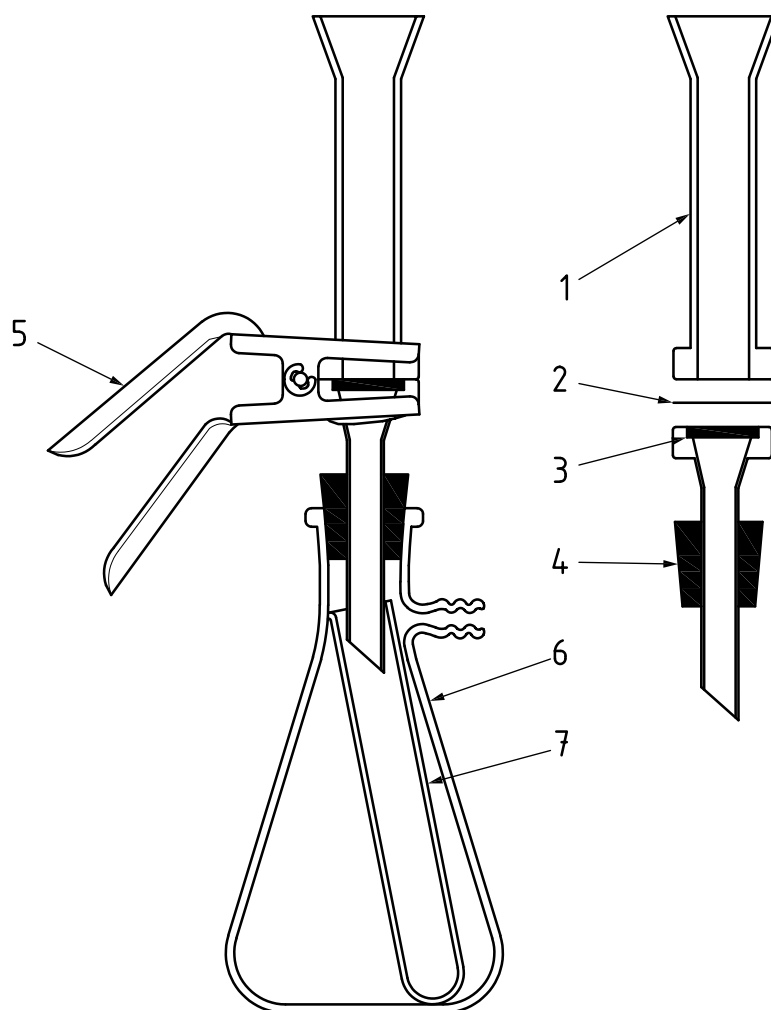

Key

- 1 filter funnel
- 2 membrane filter
- 3 fritted glass base
- 4 stopper
- 5 spring clamp
- 6 filtering flask, 250 ml
- 7 test tube, 16 mm × 95 mm

Example of a suction filtration apparatus

B.6.2.1 Open the filter transport cassettes, sampler filter cassettes or samplers and transfer each filter into an individual, labelled, 50 ml beaker (B.5.2.1) using clean flat-tipped forceps (B.5.4). Follow the same procedure for the blank filters.

NOTE If the leach is carried out in the sampler (see Note 2 in B.6.2.2), there is no need to remove the filter.

B.6.2.2 Accurately pipette 5 ml of leach solution (see B.6.1) into each beaker. If the sampler used was of a type in which airborne particles deposited on the internal surfaces of the filter cassette or sampler form part of the sample, use the leach solution to carefully wash any particulate material adhering to the internal surfaces of the sampler into the beaker.

NOTE 1 The volume of leach solution can be increased, if necessary, in order to ensure that the sample filters are fully immersed during the heating and agitation step (B.6.2.3). In this case, however, if a syringe filter is used to remove undissolved material from the sample solution, there will need to be a corresponding reduction in the further volume of leach solution added in B.6.4.1.

NOTE 2 Alternatively, the leach can be carried out in the sampler, if it is watertight when the sample outlet orifice is sealed with its protective plug and if it is of sufficient capacity. In this case, leach solution should be added to each sampler via the air inlet orifice and the samplers should be positioned in the water bath in a suitable manner, so that spillage and contamination of the sample solutions are avoided. See Reference [20] for more details.

B.6.2.3 Cover each beaker, place in a water bath (B.5.6) at $37^{\circ}\text{C} \pm 2^{\circ}\text{C}$ and agitate for 60 min, ensuring that the sample filters are fully immersed throughout the leach period. Do not use ultrasonic agitation to promote sample dissolution.

B.6.2.4 Remove undissolved material from the sample solution using suction filtration equipment, following the method specified in B.6.3, or using a syringe filter, following the method specified in B.6.4.

If a test solution is also to be prepared for determination of metals and metalloids and their insoluble compounds, it is necessary to use the method using suction filtration equipment specified in B.6.3.

B.6.3 Removal of undissolved material from the sample solution using suction filtration equipment

B.6.3.1 Filter each sample solution (B.6.2.3) through a membrane filter (B.5.7.2) using suction filtration apparatus (B.5.7.1), collecting the filtrate in an individual, labelled, 10 ml test tube (B.5.3).

If the leach was carried out in the sampler (see Note 2 in B.6.2.2), the sample filter may be used to filter the sample solution. This can be achieved by using flexible plastic tubing to connect the air outlet orifice of the sampler directly to the suction filtration apparatus (B.5.7.1), having substituted the filter funnel/support assembly with a short length of glass or plastic tubing.

B.6.3.2 Rinse the sample filter and beaker with three 1 ml aliquots of leach solution (see B.6.1), allowing the liquid to completely drain from the filter funnel between washings.

B.6.3.3 Remove the test tube from the suction filtration apparatus and accurately pipette 1 ml of nitric acid (7.2) to stabilize the solution of the metals and metalloids of interest.

B.6.3.4

Either:

a) dilute to the 10 ml graduation of the test tube with leach solution (see B.6.1), close the tube with its push-fit closure, and mix thoroughly to produce the test solution;

or

b) quantitatively transfer the filtrate (B.6.3.2) into a 10 ml volumetric flask (B.5.2.2), rinsing out the test tube with a further 1 ml of leach solution (see B.6.1). Dilute to the mark with leach solution, stopper, and mix thoroughly to produce the test solution.

The sample solution may be made up to a larger volume, if more than 10 ml of test solution is required for analysis.

B.6.3.5 If results are also required for total metals and metalloids and their compounds (see 9.3), retain the sample filters and the secondary filters (the membrane filters used for filtration of the leach solution) for subsequent analysis (see B.6.6).

B.6.4 Removal of undissolved material from the sample solution using a syringe filter

B.6.4.1 Accurately pipette a further 4 ml of leach solution (see B.6.1) into each beaker (B.6.2.3) and swirl to mix.

B.6.4.2 Accurately pipette 0,5 ml of nitric acid (7.2) into a test tube (B.5.3) to stabilize the solution of the metals and metalloids of interest.

B.6.4.3 Draw up approximately 5 ml of each sample solution (B.6.4.1) into a syringe (B.5.8.1).

B.6.4.4 Fit each syringe with a syringe filter (B.5.8.2) and dispense the sample solution through the filter into the test tube (B.6.4.2) until the liquid reaches the 5 ml graduation of the test tube. Then close the tube with its push-fit closure and mix thoroughly to produce the test solution.

B.6.4.5 Repeat the process B.6.4.2 through B.6.4.4 to filter a further aliquot of the sample solution if more than 5 ml of test solution is required to determine the elements of interest in the analytical step (see ISO 15202-3), adding sufficient nitric acid (7.2) to maintain a final test solution matrix of 1 + 9 nitric acid.

B.6.4.6 Dispose of the syringes and syringe filters after filtering one sample solution. Do not re-use to filter more sample solutions.

B.6.5 Analysis

Analyse the test solutions using the method specified in ISO 15202-3.

B.6.6 Further action to be taken when results are also required for metals and metalloids and their insoluble compounds or for total metals and metalloids and their compounds

B.6.6.1 Process the sample filters and secondary filters (B.6.3.5), if applicable, using one of the sample dissolution methods specified in Annexes C through H in order to prepare test solutions for the determination of metals and metalloids and their insoluble compounds.

B.6.6.2 Analyse the test solutions (B.6.6.1) for metals and metalloids and their insoluble compounds using the method specified in ISO 15202-3. Then add the results obtained for soluble metal and metalloid compounds to those obtained for metals and metalloids and their insoluble compounds in order to calculate the results for total metals and metalloids and their compounds.

Annex C (normative)

Sample dissolution using nitric acid and hydrochloric acid on a hotplate

C.1 Scope

C.1.1 This annex specifies a method for dissolution of metals and metalloids and their compounds on a hotplate using nitric acid, with the addition of hydrochloric acid to facilitate sample dissolution for certain elements.

NOTE For preparation of test solutions to be analysed by ICP-MS, using the method specified in ISO 30011^[11], isobaric polyatomic interferences can occur if hydrochloric acid is used in the sample dissolution. In such circumstances, the use of this acid is discouraged unless an ICP-MS collision reaction cell is used.

C.1.2 A number of procedures have been published that describe a method for dissolution of samples of airborne particulate matter on a hotplate using nitric acid or nitric acid and hydrochloric acid (see References [22], [23], [24] and [25]). The metals and metalloids covered in these procedures, and for which the sample dissolution method specified in this annex is applicable, are listed below in bold or in normal font (see C.2.1). Other metals and metalloids, for which the dissolution procedure is expected to be reasonably effective, are listed in italics (see C.2.2).

Aluminium	Calcium	Gold	Selenium	Titanium
Antimony	Cadmium	Lead	Silver	<i>Uranium</i>
Arsenic	Chromium	Magnesium	Sodium	<i>Vanadium</i>
Barium	Cobalt	Manganese	Strontium	Yttrium
Beryllium	Copper	Molybdenum	Tellurium	Zinc
Bismuth	Indium	Nickel	Thallium	Zirconium
Caesium	Iron	Potassium	Tin	

NOTE The above list is based upon the applicability of the sample dissolution procedure reported in References [22], [23], [24] and [25], with adaptation based on expert judgement. Furthermore, the list is not comprehensive and the procedure will be effective for some metals and metalloids that are not listed.

ISO 15202 is not applicable to determination of arsenic trioxide, since arsenic trioxide vapour is not collected using the sampling method specified in ISO 15202-1.

C.2 Effectiveness of the sample dissolution method

C.2.1 The specified method is believed to be fully effective for all compounds of the metals and metalloids listed in bold font. However, it might not always be effective for those listed in normal font, so that in some instances a more vigorous sample dissolution method might be required to prepare a test solution for ICP-AES analysis. If there is any doubt about whether the method will exhibit the required analytical recovery for a particular application, it is recommended that the user verifies that it is effective for dissolution of the elements of interest from the particular materials which could be present in the test atmosphere (see 10.1).

C.2.2 The specified method is expected to be reasonably effective for the metals and metalloids given in italics, but it is recommended that the user verifies that the method is effective for dissolution of the elements of interest from the particular materials which could be present in the test atmosphere (see 10.1).

C.2.3 Hydrochloric acid is used in the specified method 1) to facilitate the dissolution of certain metals and metalloids, e.g. Ag, Pb, Sb, Se, Te, some compounds of which are not readily soluble in nitric acid, or 2) to stabilize solutions of the elements concerned (see Reference [25]), or both. Its use also assists in the dissolution of samples containing high concentrations of Al or Fe (see Reference [26]).

C.2.4 A variety of other materials, e.g. oxides such as Cr_2O_3 , have a tightly packed spinel or rutile crystalline structure and are particularly resistant to acid attack. The specified method is not fully effective for many such materials and, therefore, the use of an alternative, more vigorous sample dissolution method is recommended when these could be present in the samples. See Reference [27] for information about the effectiveness of sample dissolution methods for the welding fume.

C.2.5 The specified method is not effective for the dissolution of silicates, within which the elements of interest can sometimes be bound. The use of a sample dissolution method that involves the use of hydrofluoric acid is recommended for samples that could contain a significant amount of silicate material.

C.3 Principle

C.3.1 The filter and collected sample are transferred into a beaker and heated on a hotplate with 5 ml of 1 + 1 nitric acid until about 1 ml of concentrated nitric acid solution remains.

C.3.2 The sample solution is allowed to cool and 5 ml of hydrochloric acid is added. It is then heated again until near boiling to facilitate sample dissolution for certain elements.

C.3.3 Finally, the sample solution is allowed to cool and is diluted to 25 ml with water to produce a test solution for analysis using the method specified in ISO 15202-3.

C.4 Reagents

C.4.1 **Water**, as specified in 7.1.

C.4.2 **Hydrochloric acid (HCl)**, concentrated, $\rho_{\text{HCl}} \approx 1,18 \text{ g ml}^{-1}$, $w_{\text{HCl}} \approx 36 \%$ mass fraction.

The concentration of the metals and metalloids of interest shall be less than $0,1 \mu\text{g ml}^{-1}$.

WARNING — Concentrated hydrochloric acid is corrosive and hydrochloric acid vapour is irritant. Avoid exposure by contact with the skin or eyes or by inhalation of the vapour. Use suitable personal protective equipment (e.g. gloves, face shield or safety spectacles) when working with concentrated or dilute hydrochloric acid. Handle open vessels containing concentrated hydrochloric acid in a fume hood. The vapour pressure of hydrochloric acid is high, therefore beware of pressure build-up in stoppered flasks when preparing hydrochloric acid/water mixtures.

C.4.3 **Nitric acid (HNO_3)**, concentrated, as specified in 7.2.

C.4.4 **Nitric acid**, diluted 1 + 1.

Carefully and slowly begin adding 250 ml of concentrated nitric acid (C.4.3) to 250 ml of water (C.4.1) in a 1 l polypropylene bottle (C.5.3). Add the acid in small aliquots. Between additions, swirl to mix and run cold tap water over the side of the bottle to cool the contents. Do not allow tap water to contaminate the contents of the bottle. When the addition of the concentrated nitric acid is complete, swirl the bottle to mix the contents, allow to cool to room temperature, close the bottle with its screw cap and mix thoroughly.

C.5 Laboratory apparatus

Usual laboratory apparatus and in particular the following.

C.5.1 Disposable gloves, as specified in 8.1.

C.5.2 Glassware, as specified in 8.2.

C.5.2.1 Beakers, 50 ml capacity.

C.5.2.2 One-mark volumetric flasks, 25 ml capacity.

C.5.3 Polypropylene bottle, as specified in 8.5.

A bottle made of an alternative plastic may be used provided that it is suitable for the intended use (see C.4.4).

C.5.4 Forceps, as specified in 8.3.

C.5.5 Piston-operated volumetric apparatus, as specified in 8.4, for dispensing acids (see C.6.2 and C.6.4).

C.5.6 Hotplate, thermostatically controlled, capable of maintaining the required surface temperature (see C.6.3).

NOTE The efficiency of thermostating hotplates is sometimes deficient and the surface temperature can also vary considerably with position on a hot plate having a large surface area. It may therefore be useful to characterize the performance of the hotplate before use.

C.6 Procedure

NOTE It is advisable to wear disposable gloves (C.5.1) during sample preparation, for personal protection and in order to avoid the possibility of contamination from the hands.

C.6.1 Open the filter transport cassettes, sampler filter cassettes or samplers and transfer each filter into an individual, labelled, 50 ml beaker (C.5.2.1) using clean flat-tipped forceps (C.5.4). Follow the same procedure for the blank filters.

C.6.2 Add 5 ml of 1 + 1 nitric acid (C.4.4) to each beaker and cover with a watch glass. If the sampler used was of a type in which airborne particles deposited on the internal surfaces of the filter cassette or sampler form part of the sample (see 10.3), use a suitable procedure to include these particles in the analysis. See Annex J for further guidance.

If tin is to be determined, add 5 ml of hydrochloric acid (see C.6.4) and allow to stand for several minutes before addition of 1 + 1 nitric acid in order to avoid the possible formation of insoluble SnO₂.

C.6.3 Heat the beakers on a hotplate (C.5.6) with a surface temperature of approximately 140 °C in a fume hood for approximately 10 min. Then slide back the watch glasses so that the beakers are only partially covered and continue to heat until approximately 1 ml of acid remains.

C.6.4 Remove each beaker from the hotplate and allow to cool. Then slowly and carefully add 5 ml of hydrochloric acid (C.4.2) to each beaker and wash down the inside of each beaker with a small volume of water (C.4.1).

CAUTION — Spattering can occur if the nitric acid is still hot and hydrochloric acid is added too rapidly.

C.6.5 Return the beakers to the hotplate and heat the sample solutions until they are nearly boiling. Then remove the beakers from the hotplate and allow to cool again.

C.6.6 If undissolved material is visible, follow the instructions given in Annex I for its removal or further treatment.

NOTE The presence of a visible residue does not necessarily indicate that further treatment is required. The nature of the material present in the test atmosphere and the limitations of the sample dissolution method (see C.2.3, C.2.4 and C.2.5) should be considered before deciding on whether further action is necessary.

C.6.7 Carefully wash down the watch glass and the inside of each beaker with water (C.4.1) and quantitatively transfer the solution into an individual, labelled, 25 ml volumetric flask (C.5.2.2). Dilute to the mark with water, stopper and mix thoroughly to produce the test solution.

C.6.8 Analyse the test solutions following the method specified in ISO 15202-3.

© ISO 2012

Annex D (normative)

Sample dissolution using hydrofluoric and nitric acids and ultrasonic agitation

D.1 Scope

D.1.1 This annex specifies a method for dissolution of metals and metalloids and their compounds in a mixture of concentrated hydrofluoric and nitric acids using an ultrasonic bath. The method is intended primarily for the dissolution of samples collected on quartz fibre filters.

D.1.2 The method is only applicable for use with an analytical instrument that has a corrosion-resistant sample introduction system, i.e. one that is made from materials that are not attacked by hydrofluoric acid.

D.1.3 A number of procedures have been published that describe a method for dissolution of samples of airborne particulate matter or similar environmental material using ultrasonic agitation (see References [20], [28], [29], [30], [31] and [32]). The metals and metalloids covered in these procedures, and for which the sample dissolution method specified in this annex is applicable, are listed below in bold or in normal font (see D.2.1). Other metals and metalloids, for which the dissolution procedure is expected to be reasonably effective, are listed in italics (see D.2.2).

Aluminium	Caesium	Iron	Selenium	Uranium
Antimony	Calcium	Lead	Silver	Vanadium
Arsenic	Cadmium	Magnesium	Sodium	Yttrium
Barium	Chromium	Manganese	Strontium	Zinc
Beryllium	Cobalt	Molybdenum	Tellurium	
Bismuth	Copper	Nickel	Thallium	
Boron	Indium	Potassium	Tin	

NOTE The above list is based upon the applicability of the sample dissolution procedure reported in References [20], [28], [29], [30], [31], [32] and [33], with adaptation based on expert judgement. Furthermore, the list is not comprehensive and the procedure will be effective for some metals and metalloids that are not listed.

ISO 15202 is not applicable to determination of arsenic trioxide, since arsenic trioxide vapour is not collected using the sampling method specified in ISO 15202-1.

D.2 Effectiveness of the sample dissolution method

D.2.1 The specified method is believed to be fully effective for all compounds of the metals and metalloids listed in bold font. However, it might not always be effective for those listed in normal font, so that in some instances a more vigorous sample dissolution method might be required to prepare a test solution for ICP-AES analysis. If there is any doubt about whether the method will exhibit the required analytical recovery for a particular application, it is recommended that the user verifies that it is effective for dissolution of the metals and metalloids of interest from the particular materials which could be present in the test atmosphere (see 10.1).

D.2.2 The specified method is expected to be reasonably effective for the metals and metalloids given in italics, but once again it is recommended that the user verifies that the method is effective for dissolution of the elements of interest from the particular materials which could be present in the test atmosphere (see 10.1).

D.2.3 Hydrofluoric acid facilitates the dissolution of silicate material within which the elements of interest can sometimes be bound. The use of this method, or an alternative method that also uses hydrofluoric acid, is therefore recommended for samples that could contain a significant amount of silicate material.

D.2.4 A number of elements, e.g. calcium, form sparingly soluble fluoride compounds. This should be taken into consideration when selecting the sample dissolution method to be used and one of the other specified methods should be used if a potential problem exists.

D.2.5 Ultrasonic sample dissolution methods are carried out at relatively low temperatures, but they are frequently equally effective as, and can be more effective than, hotplate methods (such as those specified in Annex C, Annex E and Annex F). However, for analysis of samples containing materials that are fairly resistant to acid attack, e.g. some stainless steel welding fumes, the use of a microwave sample dissolution method is recommended (see Annex G). See Reference [27] for information about the effectiveness of sample dissolution methods for the welding fume.

D.2.6 The specified method has been tested in a laboratory intercomparison exercise (see Reference [34]) and has been found to be effective for a range of metals and metalloids in welding fume, solder fume and geological dust samples.

D.3 Principle

D.3.1 The filter and collected sample are treated with 3 ml of hydrofluoric acid and 2 ml of nitric acid and agitated in an ultrasonic bath .

D.3.2 The sample solution is then diluted to 25 ml with water to produce a test solution for analysis using the method specified in ISO 15202-3.

D.4 Reagents

D.4.1 **Water**, as specified in 7.1.

D.4.2 **Hydrofluoric acid** (HF), concentrated, $\rho_{\text{HF}} \approx 1,16 \text{ g ml}^{-1}$, $w_{\text{HF}} \approx 48 \%$ mass fraction.

The concentration of the metals and metalloids of interest shall be less than $0,1 \mu\text{g ml}^{-1}$.

DANGER — Concentrated hydrofluoric acid is very toxic by inhalation, in contact with the skin and if swallowed. It is corrosive and causes severe burns. Avoid exposure by contact with the skin or eyes, or by inhalation of the vapour. It is ESSENTIAL that suitable personal protective equipment (including suitable gloves, face shield, etc.) is used when working with concentrated or dilute hydrofluoric acid. Handle open vessels containing concentrated hydrofluoric acid in a fume hood. See Annex A for further safety information.

D.4.3 **Nitric acid** (HNO_3), concentrated, as specified in 7.2.

D.5 Laboratory apparatus

Usual laboratory apparatus and in particular the following.

D.5.1 **Disposable gloves**, as specified in 8.1.

D.5.2 Disposable tubes, polypropylene, graduated, 50 ml capacity, with screw caps.

D.5.3 Forceps, as specified in 8.3.

D.5.4 Piston operated volumetric apparatus, as specified in 8.4, for dispensing acids (see D.6.2).

D.5.5 Filter funnels, in polypropylene, of a size suitable for use in transferring washings from the internal surfaces of the sampler (see D.6.2) into a centrifuge tube (D.5.2).

D.5.6 Ultrasonic bath, preferably with a timer.

D.6 Procedure

NOTE It is advisable to wear disposable gloves (D.5.1) during sample preparation in order to avoid the possibility of contamination from the hands and to protect them from contact with toxic and corrosive substances.

D.6.1 Open the filter transport cassettes, sampler filter cassettes or samplers and transfer each filter into an individual, labelled, 50 ml centrifuge tube (D.5.2) using clean flat-tipped forceps (D.5.3). Follow the same procedure for the blank filters.

D.6.2 Carefully add 3 ml of hydrofluoric acid (D.4.2) to each tube and, if using quartz fibre filters, wait a minute or two for the filters to dissolve. Then carefully add 2 ml of nitric acid (D.4.3) to each tube and close with a screw cap. If the sampler used was of a type in which airborne particles deposited on the internal surfaces of the filter cassette or sampler form part of the sample (see 10.3), use a suitable procedure to include these particles in the analysis. See Annex J for further guidance.

NOTE Alternatively, the leach can be carried out in the sampler, if it is watertight when the sample outlet orifice is sealed with its protective plug and if it is of sufficient capacity. In this case, leach solution should be added to each sampler via the air inlet orifice and the samplers should be positioned in the water bath in a suitable manner, so that spillage and contamination of the sample solutions are avoided. See Reference [20] for more details.

D.6.3 Adjust the water level in the ultrasonic bath (D.5.6) so that it is above the level of acid in the centrifuge tubes. Place the centrifuge tubes in a suitable rack and load into the ultrasonic bath. Agitate the samples by applying ultrasound for 1 h.

D.6.4 Remove the closure from each tube, wipe dry the outsides of each tube and make up to the 25 ml graduation with water (D.4.1). Replace the screw caps and mix thoroughly to produce the test solution.

D.6.5 If undissolved material is visible, consider whether analysis of the undissolved material is necessary and take appropriate action as specified in Annex I.

NOTE Carbonaceous material is not oxidized effectively by the method, since sample dissolution takes place at a low temperature. Undissolved carbonaceous material should not have a significant influence on the effectiveness of the method, so the presence of a visible residue after sample dissolution does not necessarily indicate that further treatment is required.

D.6.6 Analyse the test solutions using the method specified in ISO 15202-3.

Annex E (normative)

Sample dissolution using sulfuric acid and hydrogen peroxide on a hotplate

E.1 Scope

E.1.1 This annex specifies a method for dissolution of metals and metalloids and their compounds on a hotplate using sulfuric acid and hydrogen peroxide, with the addition of hydrochloric acid to facilitate sample dissolution for certain elements.

E.1.2 A procedure has been published (see Reference [35]) describing a method similar to that specified in this annex. The metals and metalloids covered in this procedure, and for which the sample dissolution method specified in this annex is applicable, are listed below in bold or in normal font (see E.2.1). Other metals and metalloids, for which the dissolution procedure is expected to be reasonably effective, are listed in italics (see E.2.2).

Aluminium	Cadmium	Lead	Selenium	<i>Titanium</i>
Antimony	Calcium	<i>Lithium</i>	Silver	<i>Uranium</i>
Arsenic	Chromium	Magnesium	<i>Sodium</i>	Vanadium
Beryllium	Cobalt	Manganese	<i>Strontium</i>	<i>Yttrium</i>
<i>Bismuth</i>	Copper	Molybdenum	Tellurium	Zinc
<i>Boron</i>	<i>Indium</i>	Nickel	<i>Thallium</i>	
<i>Caesium</i>	Iron	<i>Potassium</i>	Tin	

NOTE The above list is based upon the applicability of the sample dissolution procedure reported in Reference [35], with adaptation based on expert judgement. Furthermore, the list is not comprehensive and the procedure will be effective for some metals and metalloids that are not listed.

ISO 15202 is not applicable to determination of arsenic trioxide, since arsenic trioxide vapour is not collected using the sampling method specified in ISO 15202-1.

E.2 Effectiveness of sample dissolution method

E.2.1 The specified method is believed to be fully effective for all compounds of the metals and metalloids listed in bold font. However, it might not always be effective for those listed in normal font, so that in some instances a more vigorous sample dissolution method might be required to prepare a test solution for ICP-AES analysis. If there is any doubt about whether the method will exhibit the required analytical recovery for a particular application, it is recommended that the user verifies that it is effective for dissolution of the elements of interest from the particular materials which could be present in the test atmosphere (see 10.1).

E.2.2 The specified method is expected to be reasonably effective for the metals and metalloids given in italics, but it is recommended that the user verifies that the method is effective for dissolution of the elements of interest from the particular materials which could be present in the test atmosphere (see 10.1).

E.2.3 The specified method is not effective for the dissolution of silicate material, within which the elements of interest can sometimes be bound. The use of a sample dissolution method that involves the use of hydrofluoric acid is recommended for samples that could contain a significant amount of silicate material.

E.2.4 A variety of other materials, e.g. oxides such as Cr_2O_3 , have a tightly packed spinel or rutile crystalline structure and are particularly resistant to acid attack. The specified method is not effective for many such materials and the use of an alternative, more vigorous, sample dissolution method is recommended when these could be present in the sample.

E.2.5 A number of elements, e.g. barium, calcium and lead, form insoluble or sparingly soluble sulphates. The addition of hydrochloric acid facilitates sample dissolution for some of these elements, e.g. lead, but the potential for formation of insoluble or sparingly soluble sulphates should be taken into consideration when selecting the sample dissolution method to be used.

E.2.6 The specified method has been tested in a laboratory intercomparison exercise (see Reference [34]) and has been found to be effective for a range of metals and metalloids in welding fume, solder fume and geological dust samples.

E.3 Principle

E.3.1 The filter and collected sample are transferred into a beaker and heated on a hotplate with 2 ml of 1 + 1 sulfuric acid and a few drops of hydrogen peroxide. Hydrogen peroxide and water are removed by boiling until dense, white fumes of sulfur trioxide are evolved.

E.3.2 The sample solution is allowed to cool and 5 ml of hydrochloric acid is added. It is then heated again until near boiling to facilitate sample dissolution for certain elements.

E.3.3 Finally, the sample solution is allowed to cool and diluted to 25 ml with water to produce a test solution for analysis using the method specified in ISO 15202-3.

E.4 Reagents

E.4.1 **Water**, as specified in 7.1.

E.4.2 **Hydrochloric acid** (HCl), concentrated, as specified in C.4.2.

E.4.3 **Hydrogen peroxide** (H_2O_2), $w_{\text{H}_2\text{O}_2} \approx 30$ % mass fraction.

The concentration of the metals and metalloids of interest shall be less than $0,1 \mu\text{g ml}^{-1}$.

WARNING — Hydrogen peroxide is corrosive and oxidizing. Avoid exposure by contact with the skin or eyes. Use suitable personal protective equipment (including suitable gloves, face shield or safety spectacles, etc.) when working with hydrogen peroxide.

E.4.4 **Sulfuric acid** (H_2SO_4), concentrated, $\rho_{\text{H}_2\text{SO}_4} \approx 1,84 \text{ g ml}^{-1}$, $w_{\text{H}_2\text{SO}_4} \approx 98$ % mass fraction.

The concentration of the metals and metalloids of interest shall be less than $0,1 \mu\text{g ml}^{-1}$.

WARNING — Concentrated sulfuric acid is corrosive and causes burns. Avoid exposure by contact with the skin or eyes. Use suitable personal protective equipment (e.g. suitable gloves, face shield or safety spectacles, etc.) when working with the concentrated or dilute sulfuric acid. Fumes produced when concentrated sulfuric acid is heated are irritant. Therefore, carry out sample dissolution with sulfuric acid in a fume hood. Exercise great caution when diluting sulfuric acid with water, since this process is very exothermic. Do not add water to sulfuric acid, since it reacts violently when mixed in this manner. Prepare sulfuric acid/water mixtures by adding sulfuric acid to water.

E.4.5 Sulfuric acid, diluted 1 + 1.

Carefully and slowly begin adding 250 ml of concentrated sulfuric acid (E.4.4) to 250 ml of water (E.4.1) in a 1 l polypropylene bottle (E.5.3). Add the acid in small aliquots. Between additions, swirl to mix and run cold tap water over the side of the bottle to cool the contents. Do not allow tap water to contaminate the contents of the bottle and do not allow them to boil. When the addition of the concentrated sulfuric acid is complete, swirl the bottle to mix the contents, allow to cool to room temperature, close the bottle with its screw cap and mix thoroughly.

E.5 Laboratory apparatus

Usual laboratory apparatus and in particular the following.

E.5.1 Disposable gloves, as specified in 8.1.

E.5.2 Glassware, as specified in 8.2.

E.5.2.1 Beakers, 50 ml capacity.

E.5.2.2 One-mark volumetric flasks, 25 ml capacity.

E.5.3 Polypropylene bottle, as specified in 8.5.

A bottle made of an alternative plastic may be used provided that it is suitable for the intended use (see E.4.5).

E.5.4 Forceps, as specified in 8.3.

E.5.5 Piston-operated volumetric apparatus, as specified in 8.4, for dispensing acids (see E.6.2 and E.6.5).

E.5.6 Hotplate, as specified in C.5.6.

NOTE The efficiency of thermostating hotplates is sometimes deficient and the surface temperature can also vary considerably with position on a hotplate having a large surface area. It may therefore be useful to characterize the performance of the hotplate before use.

E.6 Procedure

NOTE It is advisable to wear disposable gloves (E.5.1) during sample preparation in order to avoid the possibility of contamination from the hands and to protect them from contact with toxic and corrosive substances.

E.6.1 Open the filter transport cassettes, sampler filter cassettes or samplers and transfer each filter into an individual, labelled, 50 ml beaker (E.5.2.1) using clean flat-tipped forceps (E.5.4). Follow the same procedure for the blank filters.

E.6.2 Add 2 ml of 1 + 1 sulfuric acid (E.4.5) and several drops of hydrogen peroxide (E.4.3) to each beaker and cover with a watch glass. If the sampler used was of a type in which airborne particles deposited on the internal surfaces of the filter cassette or sampler form part of the sample (see 10.3), use a suitable procedure to include these particles in the analysis. See Annex J for further guidance.

E.6.3 Heat the beakers on a hotplate with a surface temperature of approximately 140 °C in a fume hood for approximately 10 min.

E.6.4 Increase the temperature of the hotplate to 200 °C, slide back the watch glasses so that the beakers are only partially covered and continue to heat until dense, white sulfur trioxide fumes are evolved and approximately 1 ml of acid remains. If a solution darkens, carefully add hydrogen peroxide (E.4.3) dropwise until it becomes colourless or slightly yellow.

CAUTION — Spattering can occur if hydrogen peroxide is added too rapidly.

E.6.5 Remove each beaker from the hotplate and allow to cool. Then slowly and carefully add 5 ml of hydrochloric acid (E.4.2) to each beaker and wash down the inside of each beaker with a small volume of water (E.4.1).

CAUTION — Spattering can occur if the sulfuric acid is still hot and hydrochloric acid is added too rapidly.

E.6.6 Lower the temperature of the hotplate to 140 °C, return the beakers to the hotplate and heat until near boiling. Remove the beakers from the hotplate and allow to cool again.

E.6.7 If undissolved material is visible, follow the instructions given in Annex I for its removal or further treatment.

NOTE The presence of a visible residue does not necessarily indicate that further treatment is required. The nature of the material present in the test atmosphere and the limitations of the sample dissolution method (see E.2.3, E.2.4 and E.2.5) should be considered before deciding on what further action is necessary.

E.6.8 Carefully wash down the watch glass and the inside of each beaker with water (E.4.1) and quantitatively transfer the solution to an individual, labelled, 25 ml volumetric flask (E.5.2.2). Dilute to the mark with water, stopper and mix thoroughly to produce the test solution.

E.6.9 Analyse the test solutions using the method specified in ISO 15202-3.

Annex F (normative)

Sample dissolution using nitric acid and perchloric acid on a hotplate

F.1 Scope

F.1.1 This annex specifies a method for dissolution of metals and metalloids and their compounds on a hotplate using nitric acid and perchloric acid. Hydrochloric acid is added to facilitate sample dissolution for certain elements.

NOTE For preparation of test solutions to be analysed by ICP-MS, using the method specified in ISO 30011^[11], isobaric polyatomic interferences can occur if hydrochloric acid or perchloric acid, or both, are used in the sample dissolution. In such circumstances, the use of these acids is discouraged unless an ICP-MS collision reaction cell is used.

F.1.2 A procedure has been published (see Reference [36]) describing a method similar to that specified in this annex. The metals and metalloids covered in this procedure, and for which the sample dissolution method specified in this annex is believed to be fully effective, are listed below in bold or in normal font (see F.2.1). Other metals and metalloids, for which the dissolution procedure is expected to be reasonably effective, are listed in italics (see F.2.2).

Aluminium	Chromium	Magnesium	Selenium	Tungsten
Antimony	Cobalt	Manganese	Silver	Vanadium
Arsenic	Copper	Molybdenum	Strontium	Yttrium
Barium	Iron	Nickel	Tellurium	Zinc
Beryllium	Lanthanum	Phosphorus	Thallium	Zirconium
Cadmium	Lead	Platinum	Tin	
Calcium	Lithium	Potassium	Titanium	

NOTE The above list is based upon the applicability of the sample dissolution procedure reported in Reference [36], with adaptation based on expert judgement. Furthermore, the list is not comprehensive and the procedure will be effective for some metals and metalloids that are not listed.

ISO 15202 is not applicable to determination of arsenic trioxide, since arsenic trioxide vapour is not collected using the sampling method specified in ISO 15202-1.

F.2 Effectiveness of sample dissolution method

F.2.1 The specified method is believed to be fully effective for all compounds of the metals and metalloids listed in bold font. However, it might not always be effective for those listed in normal font, so that in some instances a more vigorous sample dissolution method might be required to prepare a test solution for ICP-AES analysis. If there is any doubt about whether the method will exhibit the required analytical recovery for a particular application, it is recommended that the user verifies that it is effective for dissolution of the elements of interest from the particular materials which could be present in the test atmosphere (see 10.1).

F.2.2 The specified method is expected to be reasonably effective for the metals and metalloids given in *italics*, but it is recommended that the user verifies that the method is effective for dissolution of the elements of interest from the particular materials which could be present in the test atmosphere (see 10.1).

F.2.3 The specified method is not effective for the dissolution of silicate material within which the elements of interest can sometimes be bound. However, it can be modified to include the use of hydrofluoric acid (see NOTE in F.6.3) and this is recommended for samples that could contain a significant amount of silicate material.

F.2.4 A variety of other materials, e.g. oxides such as Cr_2O_3 , have a tightly packed spinel or rutile crystalline structure and are particularly resistant to acid attack. The specified method is not effective for many such materials, and the use of an alternative, more vigorous, sample dissolution method is recommended when these could be present in the samples.

F.2.5 Chromium is oxidized to the hexavalent oxidation state when heated strongly with perchloric acid. It can therefore be lost from solution as chromyl chloride (CrO_2Cl_2) if the sample solution contains chloride and the precaution of reducing chromium using hydrogen peroxide is not observed (see F.6.5). Therefore the use of hydrochloric acid should be avoided if perchloric acid is used in the sample dissolution and chromium is to be determined.

F.2.6 Hydrochloric acid is used in the specified methods: 1) to facilitate sample dissolution for certain metals and metalloids, e.g. Ag, Sb, Se, Te, some compounds of which are not readily soluble in nitric acid and perchloric acid, or 2) to stabilize solutions of the elements concerned (see Reference [25]), or both. Its use also assists in the dissolution of samples containing high concentrations of Al or Fe (see Reference [26]).

F.2.7 The specified method has been tested in a laboratory intercomparison exercise (see Reference [34]) and has been found to be effective for a range of metals and metalloids in welding fume, solder fume and geological dust samples.

F.3 Principle

NOTE The specified sample dissolution method is based upon a similar method described in a published procedure (see Reference [36]). However, this has been modified to include the use of hydrogen peroxide and hydrochloric acid, as described elsewhere (see Reference [35]).

F.3.1 The filter and collected sample are transferred into a beaker and heated on a hotplate with 5 ml of nitric acid and 1 ml of perchloric acid. Nitric acid is removed by boiling until dense, white fumes of perchloric acid are evolved.

F.3.2 If the determination of chromium is required, the sample solution is allowed to cool and 1 ml of hydrogen peroxide is added to reduce chromium to the trivalent state. The sample solution is then heated again to remove the hydrogen peroxide.

F.3.3 The sample solution is allowed to cool and 5 ml of hydrochloric acid is added. It is then heated once more until near boiling to facilitate sample dissolution for certain elements.

F.3.4 Finally, the sample solution is allowed to cool and diluted to 25 ml with water to produce a test solution for analysis using the method specified in ISO 15202-3.

F.4 Reagents

F.4.1 Water, as specified in 7.1.

F.4.2 Hydrochloric acid (HCl), concentrated, as specified in C.4.2.

F.4.3 Hydrogen peroxide (H_2O_2), $w_{\text{H}_2\text{O}_2} \approx 30\%$ mass fraction, as specified in E.4.3.

F.4.4 Nitric acid, (HNO₃), concentrated, as specified in 7.2.

F.4.5 Perchloric acid (HClO₄), concentrated, $\rho_{\text{HClO}_4} \approx 1,67 \text{ g ml}^{-1}$, $w_{\text{HClO}_4} \approx 70 \%$ mass fraction.

The concentration of the metals and metalloids of interest shall be less than 0,1 $\mu\text{g ml}^{-1}$.

NOTE It might be necessary to use perchloric acid of higher purity in order to obtain an adequate detection limit for some metals and metalloids.

WARNING — Perchloric acid is corrosive and oxidizing, and its fumes are irritant. Avoid exposure by contact with the skin or eyes, or by inhalation of fumes. Use suitable personal protective equipment (including suitable gloves, face shield or safety spectacles, etc.) when working with concentrated or dilute perchloric acid, and carry out sample dissolution with perchloric acid in a fume cupboard with a scrubber unit specially designed for use with perchloric acid. See Annex A for further safety information.

F.5 Laboratory apparatus

Usual laboratory apparatus and in particular the following.

F.5.1 Disposable gloves, as specified in 8.1.

F.5.2 Glassware, as specified in 8.2.

F.5.2.1 Beakers, 50 ml capacity.

F.5.2.2 One-mark volumetric flasks, 25 ml capacity.

F.5.3 Forceps, as specified in 8.3.

F.5.4 Piston-operated volumetric apparatus, as specified in 8.4, for dispensing acids (see F.6.2, F.6.3, F.6.5 and F.6.6).

F.5.5 Hotplate, as specified in C.5.6.

NOTE The efficiency of thermostating hotplates is sometimes deficient and the surface temperature can also vary considerably with position on a hot plate having a large surface area. It may therefore be useful to characterize the performance of the hotplate before use.

F.6 Procedure

NOTE It is advisable to wear disposable gloves (F.5.1) during sample preparation in order to avoid the possibility of contamination from the hands and to protect them from contact with toxic and corrosive substances.

F.6.1 Open the filter transport cassettes, sampler filter cassettes or samplers and transfer each filter into an individual, labelled, 50 ml beaker (F.5.2.1) using clean flat-tipped forceps (F.5.3). Follow the same procedure for the blank filters.

F.6.2 Add 5 ml of nitric acid (F.4.4) to each beaker and cover with a watch glass. If the sampler used was of a type in which airborne particles deposited on the internal surfaces of the filter cassette or sampler form part of the sample (see 10.3), use a suitable procedure to include these particles in the analysis. See Annex J for further guidance.

F.6.3 Heat the beakers on a hotplate with a surface temperature of approximately 140 °C for approximately 10 min. Then slide back the watch glasses so that the beakers are only partially covered and carefully add 1 ml of perchloric acid (F.4.5). Increase the temperature of the hotplate to 175 °C and heat until dense, white

perchloric acid fumes begin to form in the beaker and approximately 1 ml of acid remains. If a solution darkens, carefully add nitric acid (F.4.4) dropwise until it becomes colourless or slightly yellow.

CAUTION — Spattering can occur if nitric acid is added too rapidly.

NOTE If the material present in the test atmosphere is believed to contain a significant amount of silicate material, its dissolution can be facilitated by adding 1 ml of hydrofluoric acid at the same time as the perchloric acid. However, it will be necessary to use heatable beakers, beaker covers, etc. that are made of plastic that is resistant to corrosion by hydrofluoric acid, e.g. a fluorocarbon polymer such as polytetrafluoroethylene (PTFE).

F.6.4 Slide the watch glasses over so that they fully cover the beaker again and continue to heat for 1 min. Remove each beaker from the hotplate and allow to cool.

F.6.5 If the determination of chromium is required, add 1 ml of hydrogen peroxide (F.4.3) to each beaker and wait a few minutes for the hydrogen peroxide to reduce chromium to its trivalent state. Then lower the temperature of the hotplate to 140 °C, return the beakers to the hotplate and boil gently for 1 min to remove the hydrogen peroxide. Finally, remove the beakers from the hotplate and allow the sample solutions to cool once more.

F.6.6 Slowly and carefully add 5 ml of hydrochloric acid (F.4.2) to each beaker and wash down the inside of each beaker with a small volume of water (F.4.1).

CAUTION — Spattering can occur if the perchloric acid is still hot and hydrochloric acid is added too rapidly.

F.6.7 Lower the temperature of the hotplate to 140 °C again, return the beakers to the hotplate and heat until near boiling. Remove the beakers from the hotplate and allow to cool again.

F.6.8 If undissolved material is visible, follow the instructions given in Annex I for its removal or further treatment.

NOTE The presence of a visible residue does not necessarily indicate that further treatment is required. The nature of the material present in the test atmosphere and the limitations of the sample dissolution method (see F.2.3, F.2.4 and F.2.5) should be considered before deciding on what further action is necessary.

F.6.9 Carefully wash down the watch glass and the inside of each beaker with water (F.4.1) and quantitatively transfer the solution into an individual, labelled, 25 ml volumetric flask (F.5.2.2). Dilute to the mark with water, stopper and mix thoroughly to produce the test solution.

F.6.10 Analyse the test solutions using the method specified in ISO 15202-3.

Annex G (normative)

Sample dissolution in a closed vessel microwave dissolution system

G.1 Scope

G.1.1 This annex specifies a method for the dissolution of metals and metalloids and their compounds in a closed vessel microwave dissolution system using nitric acid and hydrofluoric acid. Hydrofluoric acid may be omitted if its use is considered to be unnecessary, and perchloric acid may be included to improve sample dissolution efficiency, when appropriate. Hydrochloric acid is added to facilitate sample dissolution for certain elements.

NOTE With the increasing sophistication in analytical instrumentation, sample preparation has become the limiting step in the overall analysis scheme. The use of microwave-assisted methods can be advantageous, since sample dissolution times can be shortened considerably in comparison to more conventional techniques, such as hotplate dissolution. In particular, the boiling points of acids are raised when they are heated under pressure, as they are in a closed vessel microwave dissolution system. For example, the boiling point of nitric acid is elevated to between 180 °C and 190 °C at 700 kPa (100 psi), considerably above its boiling point of 120 °C at atmospheric pressure. At this higher temperature, samples are attacked more rapidly and in some cases more effectively.

G.1.2 A procedure has been published (see Reference [26]) describing a method similar to that specified in this annex. The metals and metalloids covered in this procedure, and for which the sample dissolution method specified in this annex is applicable, are listed below in bold or in normal font (see G.2.1). Other metals and metalloids, for which the dissolution procedure is expected to be reasonably effective, are listed in italics (see G.2.2).

Aluminium	Calcium	Magnesium	Selenium	Tungsten
Antimony	Chromium	Manganese	Silver	Uranium
Arsenic	Cobalt	Mercury	Sodium	Vanadium
Barium	Copper	Molybdenum	Strontium	Yttrium
Beryllium	<i>Hafnium</i>	Nickel	<i>Tantalum</i>	Zinc
<i>Bismuth</i>	<i>Indium</i>	<i>Phosphorus</i>	<i>Tellurium</i>	<i>Zirconium</i>
Boron	Iron	<i>Platinum</i>	Thallium	
<i>Caesium</i>	Lead	Potassium	<i>Tin</i>	
Cadmium	<i>Lithium</i>	<i>Rhodium</i>	<i>Titanium</i>	

NOTE The above list is based upon the applicability of the sample dissolution procedure reported in Reference [26], with adaptation based on expert judgement. Furthermore, the list is not comprehensive and the procedure will be effective for some metals and metalloids that are not listed.

ISO 15202 is not applicable to the determination of elemental mercury and arsenic trioxide, since mercury vapour and arsenic trioxide vapour are not collected using the sampling method specified in ISO 15202-1.

G.2 Effectiveness of sample dissolution method

G.2.1 The specified method is believed to be fully effective for all compounds of the metals and metalloids listed in bold font. However, it might not always be effective for those listed in normal font, so that in some

instances a more vigorous sample dissolution method might be required to prepare a test solution for ICP-AES analysis. If there is any doubt about whether the method will exhibit the required analytical recovery for a particular application, it is recommended that the user verifies that it is effective for dissolution of the elements of interest from the particular materials which could be present in the test atmosphere (see 10.1).

G.2.2 The specified method is expected to be reasonably effective for the metals and metalloids given in italics, but it is recommended that the user verifies that the method is effective for dissolution of the elements of interest from the particular materials which could be present in the test atmosphere (see 10.1).

G.2.3 The specified method prescribes a routine procedure involving the use of hydrofluoric acid, because this facilitates the dissolution of many refractory sample matrixes, e.g. certain types of welding fume, tungsten carbide, beryllium oxide and silicate material within which the elements of interest can sometimes be bound. However, if the sample does not contain such material, sample dissolution may be carried out without the use of hydrofluoric acid.

G.2.4 The specified method allows for the optional use of perchloric acid in the mixture of acids used for sample dissolution. This can give a more complete sample dissolution in some instances, e.g. when the samples contain elemental carbon. The increased oxidation potential that results from the use of perchloric acid can also improve the analytical recovery for certain metals and metalloids from certain types of material, e.g. for chromium from certain types of welding fume.

G.2.5 Hydrochloric acid is used in the specified methods, if necessary: 1) to facilitate sample dissolution for certain metals and metalloids, e.g. Ag, Sb, Se, Te, some compounds of which are not readily soluble in nitric acid, or 2) to stabilize solutions of the elements concerned (see Reference [25]), or both. Its use can assist in the dissolution of samples containing high concentrations of Al or Fe (see Reference [26]).

NOTE For preparation of test solutions to be analysed by ICP-MS using the method specified in ISO 30011^[11], the use of hydrochloric or perchloric acid is discouraged, unless a collision reaction cell is utilized, due to isobaric polyatomic interferences.

G.2.6 The specified method has been tested in a laboratory intercomparison exercise (see Reference [34]) and has been found to be effective for a range of metals and metalloids in welding fume, solder fume and geological dust samples.

G.3 Principle

G.3.1 The filter and collected sample are placed in a sealed microwave transparent vessel, treated with 4 ml of nitric acid and 1 ml of hydrofluoric acid or with 3 ml of nitric acid, 1 ml of perchloric acid and 1 ml of hydrofluoric acid, and heated under pressure in a microwave dissolution system for 25 min at a temperature of 180 °C or higher.

NOTE Hydrofluoric acid is omitted if it is considered to be unnecessary, in which case an additional 1 ml of nitric acid is used for sample dissolution.

G.3.2 If further treatment with hydrochloric acid is required (see G.2.5), the sample solution is allowed to cool, 5 ml of hydrochloric acid is added and the samples are heated under pressure in the microwave dissolution system at a temperature of 180 °C or higher for another 25 min.

G.3.3 Finally, the sample solution is allowed to cool and diluted to 25 ml with water to produce a test solution for analysis using the method specified in ISO 15202-3.

G.4 Reagents

G.4.1 **Water**, as specified in 7.1.

G.4.2 **Hydrochloric acid** (HCl), concentrated, as specified in E.4.2.

G.4.3 Hydrofluoric acid (HF), concentrated, as specified in D.4.2.

DANGER — Concentrated hydrofluoric acid is very toxic by inhalation, in contact with the skin and if swallowed. It is corrosive and causes severe burns. Avoid exposure by contact with the skin or eyes, or by inhalation of the vapour. It is **ESSENTIAL** that suitable personal protective equipment (including suitable gloves, face shield, etc.) is used when working with concentrated or dilute hydrofluoric acid. Handle open vessels containing concentrated hydrofluoric acid in a fume hood. See Annex A for further safety information.

G.4.4 Nitric acid, (HNO₃), concentrated, as specified in 7.2.

G.4.5 Perchloric acid, (HClO₄) concentrated, as specified in F.4.5.

G.4.6 Nitric acid, diluted 1 + 9, as specified in 7.3.

G.5 Laboratory apparatus

Usual laboratory apparatus and in particular the following.

G.5.1 Disposable gloves, as specified in 8.1.

G.5.2 One-mark volumetric flasks, polypropylene, 25 ml capacity.

Volumetric flasks made of an alternative plastic may be used provided that they are suitable for the intended use (see G.7.9).

G.5.3 Glassware, one-mark volumetric flasks, as specified in 8.2, 50 ml capacity.

Glass volumetric flasks should not be used for the routine procedure as they are attacked by hydrofluoric acid. They should only be used if hydrofluoric acid is not used for sample dissolution (see G.2.3).

G.5.4 Forceps, as specified in 8.3.

G.5.5 Piston-operated volumetric apparatus, as specified in 8.4, for dispensing acids (see G.7.2 and G.7.7).

G.5.6 Microwave dissolution apparatus.

CAUTION — Ensure that the manufacturer's safety recommendations are followed.

The specified method is for closed vessel microwave dissolution systems with a temperature control system. Microwave dissolution systems that are equipped only with a pressure control system or with lower pressure vessels, or both, may be used, provided that a suitable sample dissolution procedure is developed and a prior assessment of dissolution efficiency is carried out (see 10.1).

Open vessel microwave dissolution systems can give equivalent results to closed vessel microwave dissolution systems. They may therefore be used provided that a suitable sample dissolution procedure is developed and a prior assessment of dissolution efficiency is carried out (see 10.1).

G.5.6.1 Microwave dissolution system, designed for closed vessel sample dissolution in the laboratory, with power output regulation, fitted with a temperature control system capable of sensing the temperature to within ± 2 °C and automatically adjusting the microwave power output within 2 s. The microwave cavity shall be corrosion resistant and well ventilated, with all electronics protected against corrosion to ensure safe operation.

CAUTION — Domestic (kitchen) microwave ovens shall not be used, since there are very significant hazards associated with their use for the method specified in this part of ISO 15202. For example, acid vapours released into the cavity can corrode safety devices that prevent the magnetron from shutting off when the door is opened, potentially exposing the operator to microwave energy.

It is important to ensure that the contents of the vessel fitted with the temperature sensor closely resemble those in the other vessels.

NOTE A pressure control system is also very useful, since it provides a safeguard against the possibility of sample loss due to excessive pressure build-up and partial venting of the sample vessels.

G.5.6.2 Lined sample vessels, designed for carrying out microwave dissolutions at pressures up to 3 000 kPa (435 psi) or greater, designed for controlled pressure relief, capable of withstanding an operating temperature of at least 180 °C (see G.6.4), and with an internal volume of at least 50 ml. Such vessels consist of an inner liner and cover made of a microwave transparent and chemically resistant material (usually a fluorocarbon polymer such as tetra-fluoro-methoxil polymer [TFM]), which contains and isolates the sample solution from a high strength, outer pressure vessel structure. Other types of sample vessel designed to operate at equivalent or higher pressures may be used. Clean the sample vessels before use, either by soaking in 1 + 9 nitric acid (G.4.6) or by adding 5 ml of nitric acid (G.4.4) and taking through the microwave dissolution program (G.5.6.1), as appropriate, and then rinsing thoroughly with water (G.4.1).

CAUTION — Sample vessels fitted with a device to protect against over-pressurization, such as a rupture disk, are strongly recommended to minimize risk of catastrophic vessel failure and explosion.

CAUTION — The material from which the outer vessels are made is usually not as chemically resistant as the liner material. Since the outer vessels provide the strength required to withstand the high pressures within the inner liners, they shall be inspected regularly to check for any chemical or physical degradation.

G.6 Selection of acids for sample dissolution

G.6.1 Use 4 ml of nitric acid (G.4.4) and 1 ml of hydrofluoric acid (G.4.3) to carry out the routine procedure.

G.6.2 Use 3 ml of nitric acid (G.4.4), 1 ml of perchloric acid (G.4.5) and 1 ml of hydrofluoric acid (G.4.3) if it is considered that the use of perchloric acid will result in a more complete dissolution of the samples or improve the analytical recovery for the metals and metalloids of interest (see G.2.4).

G.6.3 Use 5 ml of nitric acid (G.4.4) or 4 ml of nitric acid (G.4.4) and 1 ml of perchloric acid (G.4.5) if it is believed that the sample will dissolve without the use of hydrofluoric acid (see G.2.3), e.g. if it is known that the sample matrix is not refractory.

G.6.4 Select an operating temperature of at least 180 °C for sample dissolution, taking into consideration that a higher operating temperature can lead to more efficient sample dissolution. However, ensure that the sample vessels (G.5.6.2) used are designed to withstand the selected operating temperature, which will normally not exceed 230 °C.

G.6.5 Consider whether it is necessary to add hydrochloric acid after the initial sample dissolution (see G.2.5) and, if applicable, carry out the additional step specified in G.7.7.

G.7 Procedure

NOTE It is advisable to wear disposable gloves (G.5.1) during sample preparation in order to avoid the possibility of contamination from the hands and to protect them from contact with toxic and corrosive substances.

G.7.1 Open the filter transport cassettes, sampler filter cassettes or samplers and transfer each filter into the liner of a labelled sample vessel (G.5.6.2) using clean flat-tipped forceps (G.5.4). Follow the same method for the blank filters.

G.7.2 Carefully add 5 ml of acid (see G.6) to each liner and cover with its lid. If the sampler used was of a type in which airborne particles deposited on the internal surfaces of the filter cassette or sampler form part of the sample (see 10.3), use a suitable procedure to include these particles in the analysis. See Annex J for further guidance.

G.7.3 Seal the sample vessels and place them, evenly distributed, in the turntable of the microwave dissolution system (G.5.6.1), following the manufacturer's instructions.

NOTE This method has been written assuming that a screw cap system is used to close the sample vessels. Some microwave dissolution systems employ a spring-loaded capping system, which is equally acceptable.

G.7.4 Program the microwave dissolution system (G.5.6.1) to operate the following temperature profile:

- to reach an operating temperature of at least 180 °C (see G.6.4) in less than 10 min;
- to hold the operating temperature of at least 180 °C for a further 15 min.

If hydrofluoric acid is used to dissolve the samples and the temperature sensor is not resistant to attack by this acid, the vessel in which the temperature sensor is fitted should contain a filter blank in which an equal volume of nitric acid is substituted for the hydrofluoric acid used for the dissolution of the samples.

G.7.5 When the program has run, allow the vessels to cool and the pressure to return to < 70 kPa (10 psi).

G.7.6 Remove the turntable from the microwave dissolution system and place in a fume cupboard. Carefully open each sample vessel.

G.7.7 Add 5 ml of hydrochloric acid (G.4.2) to each vessel, if required (see G.6.5), and repeat the operations specified in G.7.4, G.7.5 and G.7.6.

G.7.8 If undissolved material is visible, follow the instructions given in Annex I for its removal or further treatment.

The presence of a visible residue does not necessarily indicate that further treatment is required. The nature of the material present in the test atmosphere and the limitations of the sample dissolution method (see G.2.3, G.2.4 and G.2.5) should be considered before deciding on what further action is necessary.

G.7.9 Carefully wash the lid and sides of each liner with water (G.4.1) and quantitatively transfer the solution into an individual, labelled, 25 ml polypropylene volumetric flask (G.5.2) if hydrofluoric acid was used, or a 25 ml volumetric flask made of borosilicate glass (G.5.3) if hydrofluoric acid was not used. Dilute to the mark with water, stopper and mix thoroughly to produce the test solution.

G.7.10 Analyse the test solutions using the method specified in ISO 15202-3.

Annex H (normative)

Sample dissolution at 95 °C using a hot block

H.1 Scope

H.1.1 This annex specifies a method for the dissolution of metals and metalloids and their compounds in a hot block system operating at a nominal temperature of 95 °C, using hydrochloric acid and nitric acid. Hydrofluoric acid may be added to facilitate the dissolution of silicate material within which the elements of interest can sometimes be bound, or to facilitate the dissolution of refractory oxides such as beryllium oxide.

H.1.2 The method specified by this annex has not been demonstrated to be effective for welding fumes.

H.1.3 A procedure has been published in NIOSH Method 7303^[23] describing a sample dissolution method similar to that specified in this annex. The metals and metalloids covered in this procedure, and for which the sample dissolution method specified in this annex is applicable, are listed below in bold or in normal font (see H.2.1). Other metals and metalloids, for which the dissolution procedure is expected to be reasonably effective, are listed in italics (see H.2.2).

Aluminium	Cadmium	Indium	Nickel	Tellurium
<i>Antimony</i>	Calcium	Iron	Phosphorus	Thallium
Arsenic	Chromium	<i>Lead</i>	Platinum	<i>Tin</i>
Barium	Cobalt	Magnesium	Potassium	Vanadium
Beryllium	Copper	Manganese	Selenium	Yttrium
<i>Bismuth</i>	Gallium	Molybdenum	Sodium	Zinc
Boron				

NOTE The above list is based upon the applicability of the sample dissolution procedure reported in NIOSH Method 7303^[23], with adaptation based on expert judgement. Furthermore, the list is not comprehensive and the procedure will be effective for some metals and metalloids that are not listed.

ISO 15202 is not applicable to determination of arsenic trioxide, since arsenic trioxide vapour is not collected using the sampling method specified in ISO 15202-1.

H.2 Effectiveness of sample dissolution method

H.2.1 The specified method is believed to be fully effective for all compounds of the metals and metalloids listed in bold font. However, it might not always be effective for those listed in normal font, so that in some instances a more vigorous sample dissolution method might be required to prepare a test solution for ICP-AES analysis. If there is any doubt about whether the method will exhibit the required analytical recovery for a particular application, it is recommended that the user verifies that it is effective for dissolution of the elements of interest from the particular materials which could be present in the test atmosphere (see 10.1).

H.2.2 The specified method is expected to be reasonably effective for the metals and metalloids given in italics, but it is recommended that the user verifies that the method is effective for dissolution of the elements of interest from the particular materials which could be present in the test atmosphere (see 10.1).

H.2.3 Hydrochloric acid is used in the specified methods: 1) to facilitate the dissolution of certain metals and metalloids, e.g. Se, Te, some compounds of which are not readily soluble in nitric acid, or 2) to stabilise solutions of the elements concerned (see Reference [25]), or both. Its use also assists in the dissolution of samples containing high concentrations of Al or Fe (see Reference [26]).

NOTE For the preparation of test solutions to be analysed by ICP-MS, using the method specified in ISO 30011^[11], the use of hydrochloric acid is discouraged, unless a collision reaction cell is utilized, due to isobaric polyatomic interferences.

H.2.4 A variety of other materials, e.g. oxides such as Cr_2O_3 , have a tightly packed spinel or rutile crystalline structure and are particularly resistant to acid attack. The specified method is not fully effective for many such materials and, therefore, the use of an alternative, more vigorous sample dissolution method is recommended when these could be present in the samples.

H.3 Principle

H.3.1 The filter and collected sample are transferred into a 50 ml transparent dissolution vessel.

H.3.2 Hydrochloric acid is added to the vessel, which is then capped and heated for 15 min in a laboratory hot block dissolution system. A second heating is then carried out using nitric acid.

H.3.3 Finally, the sample solution is allowed to cool, and is then diluted with water to produce a test solution for analysis using the method specified in ISO 15202-3.

H.4 Reagents

H.4.1 **Water**, as specified in 7.1.

H.4.2 **Hydrochloric acid** (HCl), concentrated, as specified in E.4.2.

H.4.3 **Nitric acid** (HNO_3), concentrated, as specified in 7.2.

H.5 Laboratory apparatus

Usual laboratory apparatus and in particular the following.

H.5.1 **Disposable gloves**, as specified in 8.1.

H.5.2 **Forceps**, as specified in 8.3.

H.5.3 **Dissolution vessels**, plastic 50 ml vessels appropriate for the hot block apparatus being used, with caps.

H.5.4 **Hot block dissolution apparatus**, thermostatically controlled, capable of maintaining an internal temperature of 95 °C for samples being dissolved, with wells appropriate for 50 ml dissolution vessels.

H.6 Procedure

NOTE 1 It is advisable to wear disposable gloves (F.5.1) during sample preparation in order to avoid the possibility of contamination from the hands and to protect them from contact with toxic and corrosive substances.

NOTE 2 If necessary due to the size of the filter, the volume of acids can be adjusted to ensure that the filter is fully dissolved.

H.6.1 Open the filter transport cassettes, sampler filter cassettes or samplers and transfer each filter into an individual, labelled, 50 ml dissolution vessel (H.5.3) using clean, flat-tipped forceps (H.5.2). If the sampler used was of a type in which airborne particles deposited on the internal surfaces of the filter cassette or sampler form part of the sample (see 10.3), use a suitable procedure to include these particles in the analysis. See Annex J for further guidance.

H.6.2 Add 1,25 ml of hydrochloric acid (H.4.2) to each dissolution vessel, and cover with a plastic watch glass.

H.6.3 Place each dissolution vessel (H.5.3) in the hot block dissolution apparatus (H.5.4) and heat at an internal temperature of 95 °C for 15 min.

H.6.4 Remove each dissolution vessel (H.5.3) from the hot block dissolution apparatus (H.5.4) and allow to cool for at least 5 min.

H.6.5 Carefully remove the watch glass from each dissolution vessel and add 1,25 ml of nitric acid. Replace the watch glass on each dissolution vessel and return to the hot block dissolution apparatus. Heat at an internal temperature of 95 °C for 15 min.

NOTE If the material present in the test atmosphere is believed to contain a significant amount of silicate material, or refractory oxides such as beryllium oxide, its dissolution can be facilitated by adding up to 1 ml of hydrofluoric acid at the same time as the nitric acid. However, it will be necessary to use dissolution vessels, plastic watch glasses, etc., that are made of plastic that is resistant to corrosion by hydrofluoric acid, e.g. a fluorocarbon polymer such as polytetrafluoroethylene (PTFE).

H.6.6 Remove each dissolution vessel from the hot block dissolution apparatus and allow to cool for at least 5 min.

H.6.7 If undissolved material is visible, follow the instructions given in Annex I for its removal or further treatment.

The presence of a visible residue does not necessarily indicate that further treatment is required. The nature of the material present in the test atmosphere and the limitations of the sample dissolution method (see G.2.3, G.2.4 and G.2.5) should be considered before deciding on what further action is necessary.

H.6.8 Carefully remove the watch glass from each dissolution vessel and wash it down into the dissolution vessel with water.

H.6.9 Dilute each sample to a final volume of 25 ml with water. Cap and mix each sample.

CAUTION — Spattering can occur if acid is still hot and water is added too rapidly.

H.6.10 Analyse the test solutions using the method specified in ISO 15202-3.

Annex I (normative)

Action to be taken when there is visible, undissolved, particulate material after sample dissolution

I.1 Scope

This annex describes action to be taken when there is visible, undissolved, particulate material present in the sample solution after one of the sample dissolution methods described in Annexes C through H has been performed.

NOTE A number of sample dissolution methods are described in Annexes C through H for use when results are required for comparison with occupational exposure limits for total metals or metalloids, or both, and their compounds. However, these methods do not always result in complete dissolution of the sample and undissolved particulate material can remain after a method has been carried out. This needs to be removed or otherwise dealt with before analysis. It might also be important to subject the residue to a more vigorous sample dissolution method if it is considered that the undissolved material could contain any of the elements of interest.

I.2 Principle

I.2.1 If undissolved, particulate material is visible after one of the sample dissolution methods described in Annexes C through H has been performed, the sample solution and undissolved material is treated in one of a number of possible ways. The precise course of action is determined by knowledge available about the particular materials that could have been present in the test atmosphere, by the likely effectiveness of the sample dissolution method for those materials and by the availability of a sample dissolution method that is likely to be more effective for the undissolved material.

I.2.2 If it is believed that the undissolved material does not contain any of the elements of interest, then it is removed from the sample solution by filtration or centrifugation. The remaining steps of the sample dissolution method are then followed to complete the preparation of the test solution, and this is analysed as described in ISO 15202-3.

I.2.3 If it is believed that the undissolved material could contain one or more of the elements of interest and a more effective sample dissolution method is available, one of the following courses of action is taken. Either the undissolved material is separated from the sample solution by filtration and the filter and residue are transferred into an appropriate sample dissolution vessel for further processing, or the sample solution and undissolved material are quantitatively transferred into an appropriate sample dissolution vessel for further processing.

I.2.4 If it is believed that the undissolved material could contain elements of interest and a more effective sample dissolution method is not available, then the undissolved material is removed from the sample solution by filtration or centrifugation. The remaining steps of the sample dissolution method are then followed to complete preparation of the test solution and this is analysed as described in ISO 15202-3. However, an appropriate note is made in laboratory records to document the problem and the customer is informed of any shortcomings in the test report.

I.3 Reagents

I.3.1 **Water**, as specified in 7.1.

I.3.2 **Nitric acid**, diluted 1 + 9, as specified in 7.3.

NOTE 1 + 9 nitric acid is only required if undissolved particulate material is to be removed by gravity filtration through a cellulose (paper) filter (see I.5.2.2).

I.4 Laboratory apparatus

Usual laboratory apparatus and in particular the following.

I.4.1 Disposable gloves, as specified in 8.1.

I.4.2 Glassware, one-mark volumetric flasks, as specified in 8.2, 25 ml capacity.

NOTE Volumetric flasks are not required if sample solutions were made to volume in graduated centrifuge tubes and undissolved particulate material is to be removed by centrifugation (see I.5.2.1).

I.4.3 Plastic labware.

I.4.3.1 Disposable test tubes, polypropylene, graduated, 25 ml capacity, with push-fit closures or screw caps, and preferably compatible with the ICP-AES autosampler tube racks.

NOTE Test tubes without graduation are satisfactory if the samples are made up in volumetric flasks.

I.4.3.2 Disposable centrifuge tubes, as prescribed in D.5.2.

I.4.4 Centrifuge.

NOTE A centrifuge is not required if undissolved particulate material is to be removed from sample solutions by filtration (see I.5.1).

I.4.5 Gravity filtration equipment.

NOTE Gravity filtration equipment is not required if undissolved particulate material is to be removed from sample solutions by centrifugation or by suction or syringe filtration (see I.5.1).

I.4.5.1 Filter funnels, polypropylene, of a design and size suitable for filtering sample solutions into the volumetric flasks (I.4.2).

I.4.5.2 Cellulose (paper) filters, of a diameter suitable for use with the filter funnels (I.4.5.1).

I.4.6 Suction filtration equipment.

NOTE Suction filtration equipment is not required if undissolved particulate material is to be removed from sample solutions by centrifugation or by gravity or syringe filtration (see I.5.1).

I.4.6.1 Suction filtration apparatus, as specified in B.5.7.1.

I.4.6.2 Membrane filters, as specified in B.5.7.2.

I.4.7 Syringe filtration equipment.

NOTE Syringe filtration equipment is not required if undissolved particulate material is to be removed from sample solutions by centrifugation or by gravity or suction filtration (see I.5.1).

I.4.7.1 Syringes, as specified in B.5.8.1.

I.4.7.2 Syringe filters, as specified in B.5.8.2.

I.5 Procedure

NOTE It is advisable to wear disposable gloves (I.4.1) during sample preparation in order to avoid the possibility of contamination from the hands and to protect them from contact with toxic and corrosive substances.

I.5.1 Determining an appropriate course of action for dealing with undissolved, particulate material

I.5.1.1 If undissolved, particulate material is visible after one of the sample dissolution methods described in Annexes C through H has been used, decide whether it could contain any of the elements of interest by considering the nature of the particular materials that could have been present in the test atmosphere and the likely effectiveness of the sample dissolution method for the materials concerned. Refer to information in the scope clause of the annex concerned.

I.5.1.2 If it is believed that the undissolved material does not contain any of the elements of interest, then remove it by following one of the methods given in I.5.2.

I.5.1.3 If it is believed that the undissolved material could contain one or more of the elements of interest, then give further consideration to whether any other available sample dissolution method is likely to be more effective than the one originally selected (see 9.1). If this is the case, follow one of the methods given in I.5.3.

I.5.1.4 If it is believed that the undissolved material could contain one or more of the elements of interest, but after further consideration it is concluded that no other available sample dissolution method is likely to be more effective than the one originally selected (see 9.1), follow the method given in I.5.4.

I.5.2 Action to be taken when it is believed that undissolved material does not contain any of the elements of interest

I.5.2.1 Removal of undissolved material by centrifugation

I.5.2.1.1 If sample dissolution was carried out in centrifuge tubes (as in Annex D), simply centrifuge for 15 min at 2 500 rpm to produce a clear test solution.

I.5.2.1.2 If sample dissolution was carried out in beakers, microwave dissolution vessels or hot block dissolution vessels, quantitatively transfer each sample solution into an individual, labelled, 50 ml centrifuge tube (I.4.3.2), rinsing the insides of the beaker, microwave dissolution vessel or hot block dissolution vessel with several small volumes of water (I.3.1), and make up to the 25 ml graduation. Close each tube with a screw-cap or push-fit closure and centrifuge for 15 min at 2 500 rpm to produce a clear test solution.

I.5.2.2 Removal of undissolved material by gravity filtration

NOTE If sample dissolution was carried out in centrifuge tubes (e.g. as in Annex D), it is more appropriate to remove undissolved material by centrifugation (see I.5.2.1.1).

I.5.2.2.1 Fold the required number of cellulose (paper) filters (I.4.5.2) to form flutes. Place the folded filters in filter funnels (I.4.5.1) and pre-wash the filters with 1 + 9 nitric acid (I.3.2) and then with water (I.3.1).

I.5.2.2.2 Carefully wash down the inside of the beaker, microwave dissolution vessel or hot block dissolution vessel containing the sample solution with about 5 ml of water (I.3.1) and swirl to mix. Then filter each solution through a pre-washed paper filter (I.5.2.2.1), collecting the filtrate in an individual, labelled, 25 ml volumetric flask (I.4.2).

I.5.2.2.3 Rinse the inside of the beaker, microwave dissolution vessel or hot block dissolution vessel with several small volumes of water (I.3.1), allowing the liquid to completely drain from the filter funnel between washings.

I.5.2.2.4 Finally, dilute to the mark with water (I.3.1), stopper and mix thoroughly to produce the test solution.

I.5.2.3 Removal of undissolved material by suction filtration

NOTE If sample dissolution was carried out in centrifuge tubes (e.g. as in Annex D), it is more appropriate to remove undissolved material by centrifugation (see I.5.2.1.1).

I.5.2.3.1 Filter each sample solution through a membrane filter (I.4.6.2) using suction filtration apparatus (I.4.6.1), collecting the filtrate in an individual, labelled, 25 ml disposable test tube (I.4.3.1).

I.5.2.3.2 Rinse the inside of each beaker, microwave dissolution vessel or hot block dissolution vessel with several small volumes of water (I.3.1), allowing the liquid to completely drain from the filter funnel between washings.

I.5.2.3.3

Either:

a) dilute to the 25 ml graduation of the test tube with water (I.3.1), close the tube with its screw-cap or push-fit closure, and mix thoroughly to produce the test solution;

or

b) quantitatively transfer the filtrate (I.5.2.3.2) into a 25 ml volumetric flask (I.4.2), rinsing out the test tube with water (I.3.1). Dilute to the mark with water, stopper and mix thoroughly to produce the test solution.

I.5.2.4 Removal of undissolved material from the sample solution using a syringe filter

NOTE If sample dissolution was carried out in centrifuge tubes (e.g. as in Annex D), it is more appropriate to remove undissolved material by centrifugation (see I.5.2.1.1).

I.5.2.4.1 Ignoring the presence of undissolved material, quantitatively transfer each sample solution from the beaker, microwave dissolution vessel or hot block dissolution vessel in which sample dissolution was performed into a 25 ml volumetric flask (I.4.2). Rinse the insides of the beaker, microwave dissolution vessel or hot block dissolution vessel with several small volumes of water (I.3.1) and make up to the 25 ml graduation.

I.5.2.4.2 Draw up approximately 5 ml of each sample solution (I.5.2.4.1) into a syringe (I.4.7.1).

I.5.2.4.3 Fit each syringe with a syringe filter (I.4.7.2) and dispense the sample solution through the filter into the test tube (I.4.3.1).

I.5.2.4.4 Repeat the process I.5.2.4.2 through I.5.2.4.3 to filter a further aliquot or aliquots of the sample solution if more than 5 ml of solution is required to determine the elements of interest in the analytical step (see ISO 15202-3).

I.5.2.4.5 Close the tube with its push-fit closure and mix thoroughly to produce the test solution.

I.5.2.4.6 Dispose of the syringes and syringe filters after filtering one sample solution. Do not re-use to filter more sample solutions.

I.5.3 Action to be taken when undissolved material could contain one or more of the elements of interest and a more effective sample dissolution method is available

I.5.3.1 Action to be taken when undissolved material is to be removed and processed using a more effective sample dissolution method

I.5.3.1.1 Use the method described in I.5.2.3 to prepare primary test solutions and remove undissolved particulate material by suction filtration.

I.5.3.1.2 Retain the secondary filters (the membrane filters used for filtration of the sample solution) and the sample filters (if not dissolved) for subsequent analysis (see I.5.3.1.3).

I.5.3.1.3 Prepare secondary test solutions by processing the secondary filters and the sample filters, if appropriate (see I.5.3.1.2), using a sample dissolution method that is believed to be more effective than the one originally selected (see I.5.1.3).

I.5.3.1.4 After the primary test solutions (I.5.2.3.3) and secondary test solutions (I.5.3.1.3) have been analysed following the method described in ISO 15202-3, sum the results concerned to obtain results for total metals and metalloids and their compounds.

I.5.3.2 Action to be taken when the sample solution and undissolved material is to be reprocessed using a more effective sample dissolution method

NOTE Sometimes when undissolved material is believed to contain one or more of the elements of interest, it can be more appropriate to reprocess the sample solution and undissolved material together, rather than remove the undissolved material by filtration and reprocess it separately. For example, this is sensible, for safety reasons, when the sample solution contains hydrofluoric acid.

I.5.3.2.1 Transfer the sample solution, the undissolved material and the sample filter (if not dissolved) into a sample dissolution vessel that is compatible with the reagents used in the first sample dissolution method and with the reagents and conditions used in the second sample dissolution method.

NOTE If hydrofluoric acid is used in either of the sample dissolution methods concerned, it will be necessary to use a heatable beaker, microwave dissolution vessel or hot block dissolution vessel made of a suitable chemically resistant material (usually a fluorocarbon polymer).

I.5.3.2.2 Rinse the inside of the first sample dissolution vessel with the least hazardous reagent used in the second sample dissolution method and then also add this to the second sample dissolution vessel.

I.5.3.2.3 Prepare test solutions by reprocessing the sample solutions and undissolved material using the sample dissolution method that is believed to be more effective than the one originally selected (see I.5.1.3).

NOTE It might be necessary to apply an intermediate step to remove the reagents used in the first sample dissolution method, e.g. to boil off acids not required in the second sample dissolution method.

I.5.4 Action to be taken when undissolved material is believed to contain one or more of the elements of interest, but a more effective sample dissolution method is not available

I.5.4.1 Use any of the methods described in I.5.2.3 to prepare the test solutions and remove undissolved particulate material.

I.5.4.2 Make an appropriate note in the laboratory records to document the fact that undissolved material was present after sample dissolution and it is believed that this could contain one or more of the elements of interest.

I.5.4.3 Analyse the test solutions following the method described in ISO 15202-3, but inform the customer of the analytical shortcomings in the test report. Highlight, in particular, which elements could have low results.

Annex J (informative)

Sampler wall deposits

J.1 Scope

This annex provides information, based on References [37], [38], [39] and [40], on methods for accounting for deposits of particulate matter on the interior walls of a transport cassette or sampler (see 10.3).

J.2 Samplers

Samplers for aerosols typically consist of a filter supported in a holder, though other collection substrates are also used, e.g. impaction plates and foams. The entire device is considered to be an aerosol sampler. The sampling efficiency of an aerosol sampler is considered to be the air concentration calculated from the particulates collected by the sampler compared to the undisturbed concentration in air. All aerosol samplers exhibit a decrease in sampling efficiency with increasing particulate aerodynamic diameter. Size-selective samplers are designed for a specific sampling efficiency over a range of aerodynamic diameters, known as a sampling convention (see ISO 7708^[4]), in which case the actual sampling efficiency of the sampler is considered with reference to the relevant sampling convention. In some sampler designs, e.g. cyclones, there is an internal separator to achieve the required size selection.

J.3 Collection efficiency

The collection efficiency of an aerosol sampler has four components: (i) aspiration efficiency; (ii) transfer efficiency within the sampler (either from the sampler inlet to the collection substrate or, if an internal separator is present, both from the sampler inlet to the internal separator and from the internal separator to the collection substrate); (iii) penetration efficiency (through the internal separator, if present); and (iv) the capture efficiency of the collection substrate (e.g. filtration efficiency, when the collection substrate is a filter). For any given design of sampler, the various components are functions of particle aerodynamic size and air flow rate through the sampler. The aspiration efficiency also depends on wind speed and direction, while the sampler's angle to the vertical influences both aspiration and transport efficiency. Part of the sample will deposit on internal surfaces of the sampler as a result of losses during passage within the sampler. In addition, if the sampler is transported after sampling, particles deposited on the substrate can become dislodged and add to deposits already on the internal surfaces of the sampler (although this is likely of lesser importance, except when the collection substrate is overloaded with sample). If the design specification for the sampler is to include all aspirated particles, these losses need to be taken into account. Table J.1 provides examples of median values of deposits on the walls for two commercially available samplers in common use, taken from data in References [37], [38], [39] and [40]. No pattern can be discerned from this data that would allow the use of correction factors.

For some samplers, the sample deposited on the collection substrate is considered to be the entire sample; i.e., wall deposits are not considered to be part of the sample. For other samplers, it is recommended that the wall deposits are evaluated.

J.4 Procedures

There exist several procedures that could be used to account for wall deposits. One method is extraction or sample dissolution within the body of the sampler, which is the practice in some French methods, See, for example, Reference [20]. Another procedure, often followed, is to rinse the internal deposit into the extraction or sample dissolution vessel containing the collection substrate. This can be quantitative if the deposit is very soluble or easily displaced, but that might not be the case. Brushing the deposit into the dissolution vessel

might not be quantitative and could be a source of contamination (see Reference [33]). A procedure that has been tested in a limited evaluation and shown to be quantitative for selected applications is wet-wiping of the internal surfaces (see Reference [41]).

J.5 Wiping internal surfaces

Wiping the internal surfaces of a sampler with a wetted wipe allows a combination of mechanical removal with wetting and solubilisation. The choice of wipe is important. It has to be free of significant contamination and compatible with the sample preparation and analytical procedure to be used. The mass of the wipe should not be so large as to unduly compromise analytical detection limits. If the wipe material cannot be prepared and analysed in the same way as the collection substrate, it may be analysed as a separate sample and the results combined.

J.6 Contribution to the uncertainty budget

Where an air sampling and analytical method includes a specific procedure for recovering and analysing wall deposits, this needs to be taken into account when estimating the expanded uncertainty of the method.

Median wall deposits for closed-face cassette (CFC) and IOM samplers

Industry	Analyte	CFC samplers		IOM samplers	
		Median wall deposit %	<i>n</i>	Median wall deposit %	<i>n</i>
Copper smelter	Cu	21	18	16	17
Lead ore mill	Pb	19	9	19	8
Solder manufacture	Pb	29	30		
Battery production	Pb	28	16	8	11
Welding	Cr (VI)	5	10		
Welding	Al			3	18
Plating	Cr (VI)	12	12		
Paint spray	Cr (VI)	7	29		
Foundry	Zn	53	9		
Zinc plating	Zn	27	18		
Cast iron foundry	Fe	22	18	8	18
Grey iron foundry	Fe	24	18	5	18
Bronze foundry	Cu, Pb, Sn, Zn	19, 13, 0, 15	6	0, 0, 0, 3	6
Cuproberyllium	Cu, Be	31, 12	4		

Bibliography

- [1] ISO 1042, *Laboratory glassware — One-mark volumetric flasks*
- [2] ISO 3585, *Borosilicate glass 3.3 — Properties*
- [3] ISO 3696, *Water for analytical laboratory use — Specification and test methods*
- [4] ISO 7708, *Air quality — Particle size fraction definitions for health-related sampling*
- [5] ISO 8518, *Workplace air — Determination of particulate lead and lead compounds — Flame or electrothermal atomic absorption spectrometric method*
- [6] ISO 8655-1, *Piston-operated volumetric apparatus — Part 1: Terminology, general requirements and user recommendations*
- [7] ISO 8655-2, *Piston-operated volumetric apparatus — Part 2: Piston pipettes*
- [8] ISO 8655-5, *Piston-operated volumetric apparatus — Part 5: Dispensers*
- [9] ISO 8655-6, *Piston-operated volumetric apparatus — Part 6: Gravimetric methods for the determination of measurement error*
- [10] ISO 11174, *Workplace air — Determination of particulate cadmium and cadmium compounds — Flame and electrothermal atomic absorption spectrometric method*
- [11] ISO 30011, *Workplace air — Determination of metals and metalloids in airborne particulate matter by inductively coupled plasma mass spectrometry*
- [12] EN 482, *Workplace exposure — General requirements for the performance of procedures for the measurement of chemical agents*
- [13] EN 1540:2011, *Workplace atmospheres — Terminology*
- [14] EN 14902:2005, *Ambient air quality — Standard method for the measurement of Pb, Cd, As and Ni in the PM 10 fraction of suspended particulate matter*
- [15] ACGIH. *Threshold limit values for chemical substances and physical agents; biological exposure indices*. American Conference of Government Industrial Hygienists, Cincinnati, OH (updated annually). Available (2011-05-10) at www.acgih.org
- [16] EUROPEAN COMMISSION. Commission Directive 2006/15/EC of 7 February 2006 establishing a second list of indicative occupational exposure limit values in implementation of Council Directive 98/24/EC and amending Directives 91/322/EEC and 2000/39/EC. *Off. J. Eur. Commun.* 2006, **L38**, pp. 36-39. Available (2011-05-10) at <http://eur-lex.europa.eu/LexUriServ/LexUriServ.do?uri=OJ:L:2006:038:0036:0039:EN:PDF>
- [17] EUROPEAN COMMISSION. Council Directive 98/24/EC of 7 April 1998 on the protection of the health and safety of workers from the risks related to chemical agents at work (fourteenth individual Directive within the meaning of Article 16(1) of Directive 89/391/EEC). *Off. J. Eur. Commun.* 1998, **L31**, pp. 11-23. Available (2011-05-10) at <http://eur-lex.europa.eu/LexUriServ/LexUriServ.do?uri=OJ:L:1998:131:0011:0023:EN:PDF>
- [18] NIOSH. NIOSH Manual of Analytical Methods: Method 7056 *Barium, soluble compounds* and Method 7074 *Tungsten (soluble and insoluble)*. National Institute for Occupational Safety and Health, Cincinnati, OH, USA (updated periodically). Available (2011-05-10) at <http://www.cdc.gov/niosh/docs/2003%2D154/>
- [19] HSE. Methods for the Determination of Hazardous Substances: MDHS 42/2 *Nickel and inorganic compounds of nickel in air (except nickel carbonyl)* and MDHS 46/2 *Platinum metal and soluble platinum*

- compounds in air*. Health and Safety Executive, Bootle, United Kingdom (updated periodically). Available (2011-05-10) at <http://www.hse.gov.uk/pubns/mdhs/pdfs/mdhs42-2.pdf>
- [20] INRS. Base de données MétroPol (Métrologie des polluants — Évaluation de l'exposition professionnelle — Méthodes de prélèvement et d'analyse de l'air): Fiche 003 *Métaux - métalloïdes*. Institut National de recherche et de Sécurité, Nancy, France (updated periodically). Available (2011-05-10) at [http://www.inrs.fr/inrs-pub/inrs01.nsf/inrs01_metropol_view/BAAA696CD193E206C1256D5C0041B8D1/\\$File/003.pdf](http://www.inrs.fr/inrs-pub/inrs01.nsf/inrs01_metropol_view/BAAA696CD193E206C1256D5C0041B8D1/$File/003.pdf)
- [21] DRAKE, P, MARCY, A D., ASHLEY, K. Evaluation of a standardized method for determining soluble silver in workplace air samples. *J. Environ. Monit.* 2006, **8**, pp. 134-139
- [22] HSE. Methods for the Determination of Hazardous Substances: MDHS 6/3 *Lead and inorganic compounds of lead in air*, MDHS 10/2 *Cadmium and inorganic compounds of cadmium in air*, MDHS 12/2 *Chromium and inorganic compounds of chromium in air*, MDHS 29/2 *Beryllium and beryllium compounds in air*, MDHS 30/2 *Cobalt and cobalt compounds in air* and MDHS 42/2 *Nickel and inorganic compounds of nickel in air (except nickel carbonyl)*. Health and Safety Executive, Bootle, United Kingdom (updated periodically). Available (2011-05-10) at <http://www.hse.gov.uk/pubns/mdhs/>
- [23] NIOSH. NIOSH Manual of Analytical Methods: Method 7013 *Aluminium and compounds, as Al*, Method 7024 *Chromium and compounds, as Cr*, Method 7027 *Cobalt and compounds, as Co*, Method 7029 *Copper (dust and fume)*, Method 7030 *Zinc and compounds, as Zn*, Method 7048 *Cadmium and compounds, as Cd*, Method 7082 *Lead by flame AAS*, Method 7105 *Lead by GFAAS*, Method 7303 *Elements by ICP (Hot block/HCl/HNO₃ digestion)* and Method 7901 *Arsenic trioxide, as As*. National Institute for Occupational Safety and Health, Cincinnati, OH (updated periodically). Available (2011-05-10) at <http://www.cdc.gov/niosh/docs/2003%2D154/>.
- [24] OSHA. Sampling and Analytical Methods: Method ID-105 *Inorganic arsenic in workplace atmospheres*, Method ID-189 *Cadmium in workplace atmospheres* and Method ID-206 *Metal and metalloid particulates from solder operations*. Occupational Safety and Health Administration, Sandy, UT, USA (updated periodically). Available (2011-05-10) at <http://www.osha.gov/dts/sltc/methods/inorganic/id105/id105.html>
- [25] OSHA. Sampling and Analytical Methods: Method ID-121 *Metals and metalloid particulates in workplace atmospheres (atomic absorption)*. Occupational Safety and Health Administration, Sandy, UT, USA (updated periodically). Available (2011-05-10) at <http://www.osha.gov/dts/sltc/methods/inorganic/id121/id121.html>
- [26] EPA. Test methods for evaluating solid waste, physical/chemical methods: Method 3052 *Microwave assisted acid digestion of siliceous and organically based matrices*. Environmental Protection Agency, Washington, DC, USA. Available (2011-05-10) at <http://www.epa.gov/waste/hazard/testmethods/sw846/pdfs/3052.pdf>
- [27] STACEY, P., BUTLER, O. Performance of laboratories analysing welding fume on filter samples - Results from the WASP proficiency testing scheme. *Ann. Occup. Hyg.* 2008, **52**, pp. 287-295
- [28] ASHLEY, K. Ultrasonic extraction of heavy metals from environmental and industrial hygiene samples for their subsequent determination. *Trends Anal. Chem.* 1998, **17**, pp. 366-372
- [29] HARPER, S.L., WALLING, J. F., HOLLAND, D.M., PRANGER L.J. Simplex optimisation of multielement extraction of atmospheric particles. *Anal. Chem.* 1983, **55**, pp. 1553-1557
- [30] SANCHEZ, J., GARCIA, R., MILLAN, E. Ultrasonic bath digestion procedures for analysis of heavy metals in several reference materials. *Analisis.* 1994, **22**, pp. 222-225
- [31] SIAKA, M., OWENS, C.M., BIRCH, G.F. Evaluation of some digestion methods for the determination of heavy metals in sediment samples by flame-AAS. *Anal. Lett.* 1998, **31**, pp. 703-718
- [32] JALKANEN, L., HASANEN, E. A simple method for the dissolution of atmospheric aerosol samples for analysis by inductively coupled plasma mass spectrometry, *J. Anal. At. Spectrom.* 1996, **11**, pp. 365-369

- [33] ASHLEY, K., ANDREWS, R.N., CAVAZOS, L. DEMANGE, M., Ultrasonic extraction as a sample preparation technique for elemental analysis by atomic spectrometry. *J. Anal. At. Spectrom.* 2001, **16**, pp. 1147-1153
- [34] BUTLER, O.T., HOWE, A.M. Development of an international standard for the determination of metals and metalloids in workplace air using ICP-AES: Evaluation of sample dissolution procedures through an interlaboratory trial. *J. Environ. Monit.* 1999, **1**, pp. 23-32
- [35] OSHA. Sampling and Analytical Methods: Method ID-125G *Metals and metalloid particulates in workplace atmospheres (ICP analysis)*. Occupational Safety and Health Administration, Sandy, UT, USA (updated periodically). Available (2011-05-10) at <http://www.osha.gov/dts/sltc/methods/inorganic/id125g/id125g.html>
- [36] NIOSH. NIOSH Manual of Analytical Methods: Method 7300 *Elements (ICP)*. National Institute for Occupational Safety and Health, Cincinnati, OH (updated periodically). Available (2011-05-10) at <http://www.cdc.gov/niosh/docs/2003%2D154/pdfs/7300.pdf>
- [37] HARPER, M., DEMANGE, M. Concerning sampler wall deposits in the chemical analysis of airborne metals. *J. Occup. Environ. Hyg.* 2007, **4**, pp. D81-D86
- [38] DEMANGE, M., GENDRE, J.C., HERVÉ-BAZIN, B., CARTON, B., PELTIER, A. Aerosol evaluation difficulties due to particle deposition on filter holder inner walls. *Ann. Occup. Hyg.* 1990, **34**, pp. 399-403
- [39] HETLAND, S., THOMASSEN, Y. Sampling and chemical characterization of aerosols in workplace air. *Pure Appl. Chem.* 1993, **65**, pp. 2417-2422
- [40] DEMANGE, M., GÖRNER, P., ELCABACHE, J-M., WROBEL, R. Field comparison of 37-mm closed-face cassettes. *Appl. Occup. Environ. Hyg.* 2002, **17**, pp. 200-208
- [41] HENDRICKS, W., STONES, F., LILLQUIST, D. On wiping the interior walls of 37-mm closed-face cassettes – An OSHA perspective. *J. Occup. Environ. Hyg.* 2009, **6**, pp. 732-734

ICS 13.040.30

Price based on 47 pages