**Connections for fluid power and
general use — Hydraulic couplings for
diagnostic purposes —**

Part 2:
**Coupling with M16 x 2 end for
connection under pressure**

*Raccordements pour transmissions hydrauliques et pneumatiques et
usage général — Raccords hydrauliques pour diagnostics —*

Partie 2: Raccord avec extrémité M16 x 2 pour connexion sous pression



COPYRIGHT PROTECTED DOCUMENT

© ISO 2016, Published in Switzerland

All rights reserved. Unless otherwise specified, no part of this publication may be reproduced or utilized otherwise in any form or by any means, electronic or mechanical, including photocopying, or posting on the internet or an intranet, without prior written permission. Permission can be requested from either ISO at the address below or ISO's member body in the country of the requester.

ISO copyright office
Ch. de Blandonnet 8 • CP 401
CH-1214 Vernier, Geneva, Switzerland
Tel. +41 22 749 01 11
Fax +41 22 749 09 47
copyright@iso.org
www.iso.org

Contents

Page

Foreword	iv
Introduction	v
1 Scope	1
2 Normative references	1
3 Terms and definitions	2
4 Performance requirements	2
4.1 General.....	2
4.2 Working pressure and temperature	2
4.3 Flow rate and pressure drop.....	2
4.4 Connection of the coupling with a coupling counterpart.....	2
4.5 Burst and cyclic endurance (impulse) test pressures	3
4.6 Test requirements	3
5 Design	3
5.1 Basic dimensions.....	3
5.2 Diagnostic coupling with a stud end ISO 6149-2, M14 × 1,5.....	5
5.3 Diagnostic coupling with a stud end ISO 9974-2, M14 × 1,5.....	5
5.4 Diagnostic coupling with a stud end ISO 1179-2, G1/4.....	5
5.5 Diagnostic coupling with a stud end ISO 11926-2, 7/16-20 UNF.....	6
6 Manufacture	6
6.1 Construction.....	6
6.2 Workmanship.....	6
6.3 Finish.....	7
7 Designation of couplings	7
8 Marking	7
9 Identification statement (reference to this part of ISO 15171)	7
Annex A (informative) Other hydraulic connection types suitable for diagnostic couplings	8
Bibliography	9

Foreword

ISO (the International Organization for Standardization) is a worldwide federation of national standards bodies (ISO member bodies). The work of preparing International Standards is normally carried out through ISO technical committees. Each member body interested in a subject for which a technical committee has been established has the right to be represented on that committee. International organizations, governmental and non-governmental, in liaison with ISO, also take part in the work. ISO collaborates closely with the International Electrotechnical Commission (IEC) on all matters of electrotechnical standardization.

The procedures used to develop this document and those intended for its further maintenance are described in the ISO/IEC Directives, Part 1. In particular the different approval criteria needed for the different types of ISO documents should be noted. This document was drafted in accordance with the editorial rules of the ISO/IEC Directives, Part 2 (see www.iso.org/directives).

Attention is drawn to the possibility that some of the elements of this document may be the subject of patent rights. ISO shall not be held responsible for identifying any or all such patent rights. Details of any patent rights identified during the development of the document will be in the Introduction and/or on the ISO list of patent declarations received (see www.iso.org/patents).

Any trade name used in this document is information given for the convenience of users and does not constitute an endorsement.

For an explanation on the meaning of ISO specific terms and expressions related to conformity assessment, as well as information about ISO's adherence to the WTO principles in the Technical Barriers to Trade (TBT) see the following URL: [Foreword - Supplementary information](#).

The committee responsible for this document is ISO/TC 131, *Fluid power systems*, Subcommittee SC 4, *Connectors and similar products and components*.

This second edition cancels and replaces the first edition (ISO 15171-2:2000), which constitutes a minor revision.

ISO 15171 consists of the following parts, under the general title *Connections for fluid power and general use — Hydraulic couplings for diagnostic purposes*:

- *Part 1: Coupling not for connection under pressure*
- *Part 2: Coupling with M16 × 2 end for connection under pressure*

Introduction

In fluid power systems, power is transmitted and controlled through a fluid (liquid or gas) under pressure within a circuit. In general applications, a fluid can be conveyed under pressure.

Components are equipped with ports providing diagnostic points in a hydraulic system. Diagnostic couplings can be installed to aid in the diagnosis of hydraulic systems.

For threaded ports and stud ends specified in new designs in hydraulic fluid power applications, ISO/TC 131/SC 4 recommends that the ISO 6149 series be used because these International Standards specify ports and stud ends with metric threads and O-ring sealing and because the sub-committee would like to help users by recommending one preferred system. ISO/TC 131/SC 4 further recommends that threaded ports and stud ends in accordance with the ISO 1179 series, ISO 9974 series and ISO 11926 series not be used for new designs in hydraulic fluid power applications; these International Standards will be maintained because they specify ports and stud ends that are currently used in hydraulic systems worldwide.

Connections for fluid power and general use — Hydraulic couplings for diagnostic purposes —

Part 2:

Coupling with M16 x 2 end for connection under pressure

1 Scope

This part of ISO 15171 specifies dimensions, performance requirements, and test procedures for diagnostic couplings with an M16 × 2 connection end that can be connected under pressure without tools to a maximum pressure of 40 MPa (400 bar) providing following stud ends:

- ISO 6149-2 – M14 × 1,5;
- ISO 9974-2 – M14 × 1,5;
- ISO 1179-2 – G 1/4;
- ISO 11926-2 – 7/16-20 UNF.

The dimensions of the coupler counterpart are specified. The coupling is designed for use in hydraulic systems that use mineral oils.

NOTE The use of this coupling with fluids other than mineral oil requires an agreement between the supplier and the purchaser.

Couplings in accordance with this part of ISO 15171 may be used at a maximum working pressure of 63 MPa (630 bar). The working pressure depends upon the materials, design, working conditions, application, etc.

2 Normative references

The following documents, in whole or in part, are normatively referenced in this document and are indispensable for its application. For dated references, only the edition cited applies. For undated references, the latest edition of the referenced document (including any amendments) applies.

ISO 724, *ISO general-purpose metric screw threads — Basic dimensions*

ISO 965-1, *ISO general purpose metric screw threads — Tolerances — Part 1: Principles and basic data*

ISO 1179-2, *Connections for general use and fluid power — Ports and stud ends with ISO 228-1 threads with elastomeric or metal-to-metal sealing — Part 2: Heavy-duty (S series) and light-duty (L series) stud ends with elastomeric sealing (type E)*

ISO 1629, *Rubber and latices — Nomenclature*

ISO 5598, *Fluid power systems and components — Vocabulary*

ISO 6149-2, *Connections for hydraulic fluid power and general use — Ports and stud ends with ISO 261 metric threads and O-ring sealing — Part 2: Dimensions, design, test methods and requirements for heavy-duty (S series) stud ends*

ISO 9227, *Corrosion tests in artificial atmospheres — Salt spray tests*

ISO 15171-2:2016(E)

ISO 9974-2, *Connections for general use and fluid power — Ports and stud ends with ISO 261 threads with elastomeric or metal-to-metal sealing — Part 2: Stud ends with elastomeric sealing (type E)*

ISO 11926-2, *Connections for general use and fluid power — Ports and stud ends with ISO 725 threads and O-ring sealing — Part 2: Heavy-duty (S series) stud ends*

ISO 18869,¹⁾ *Hydraulic fluid power — Test methods for couplings actuated with or without tools*

ISO 19879, *Metallic tube connections for fluid power and general use — Test methods for hydraulic fluid power connections*

3 Terms and definitions

For the purposes of this document, the terms and definitions given in ISO 5598 apply.

4 Performance requirements

4.1 General

Conformance to the dimensional information in this part of ISO 15171 does not guarantee rated performance. Each manufacturer shall perform testing according to the specification contained in this part of ISO 15171 to ensure that components comply with the performance rating.

4.2 Working pressure and temperature

Couplings shall be designed for use at a maximum working pressure of 63 MPa (630 bar) within a temperature range from -20 °C to +120 °C.

NOTE The temperature range of couplings with elastomeric seals depends on the limits of the temperature range of the seals.

4.3 Flow rate and pressure drop

4.3.1 At a flow rate of 6 l/min, the pressure drop of the diagnostic coupling shall not exceed 20 MPa (200 bar).

4.3.2 The value of the pressure drop does not include the pressure drop for the hose pin, which is necessary in order to carry out the measurements. The pressure drop test shall be conducted in accordance with ISO 18869¹⁾ and the special provisions given in [4.3.2.1](#) to [4.3.2.3](#).

4.3.2.1 Conduct a pressure drop test with the complete coupling.

4.3.2.2 Conduct a pressure drop test with the poppet and spring removed from the coupling.

4.3.2.3 Subtract the value of the pressure drop obtained from [4.3.2.2](#) from the pressure drop obtained from [4.3.2.1](#). The result is the net pressure drop.

NOTE The rating of the male half of the coupling is to be considered without the pressure drop of the pin.

4.4 Connection of the coupling with a coupling counterpart

If a coupling counterpart is used as described in [Clause 5](#), it shall be ensured that the coupling is sealed before the pin opens the male coupling half.

1) To be published.

The thread engagement between both parts shall be not less than two pitches before opening.

4.5 Burst and cyclic endurance (impulse) test pressures

Couplings shall meet at least a burst pressure of 252 MPa (2 520 bar) and a cyclic endurance (impulse) pressure of 84 MPa (840 bar) when tested in accordance with [4.6](#).

4.6 Test requirements

4.6.1 Testing shall be conducted in accordance with ISO 19879 for burst and cyclic endurance (impulse) tests.

4.6.2 The test samples shall be tightened to a torque in accordance with the applicable International Standard, mentioned in [5.2](#) to [5.5](#).

4.6.3 The coupling shall meet the following requirements:

- without any cap;
- assembled with a protection cap;
- assembled with the coupling counterpart.

4.6.4 After the cyclic endurance test, it shall be possible to disconnect and reconnect the coupling without leakage or malfunction. The results shall be reported using the form given in ISO 19879.

5 Design

5.1 Basic dimensions

5.1.1 Basic dimensions of the coupling shall conform to those given in [Figure 1](#). Stud end and seals shall be in accordance with the applicable International Standard, mentioned in [5.2](#) to [5.5](#).

5.1.2 The dimensions for the coupling counterpart are shown in [Figure 2](#).

5.1.3 The M16 × 2 thread conforms to ISO 724, tolerance grade 6g for external and 6H for internal thread in accordance with ISO 965-1.

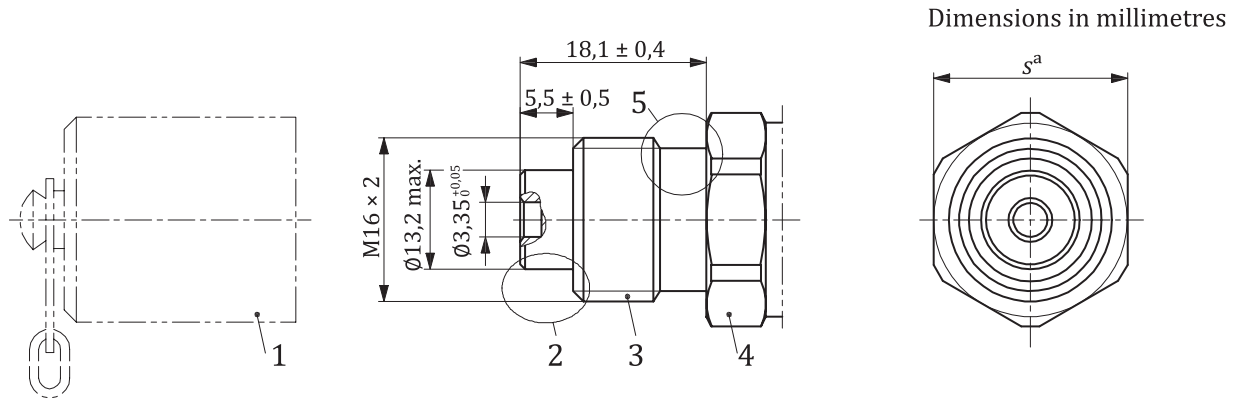

Key

- 1 design of the cap at the discretion of the manufacturer
- 2 design at the discretion of the manufacturer
- 3 diagnostic connection
- 4 optional design
- 5 vibration lock at the discretion of the manufacturer
- a $s = 19$ for types FM $14 \times 1,5$, EM $14 \times 1,5$ and EG $1/4$ (5.2, 5.3, and 5.4, respectively); $s = 17$ for type FU $7/16-20$ (5.5), tolerance for s is ${}^0_{-0,2}$.

Figure 1 — Basic dimensions for diagnostic coupling

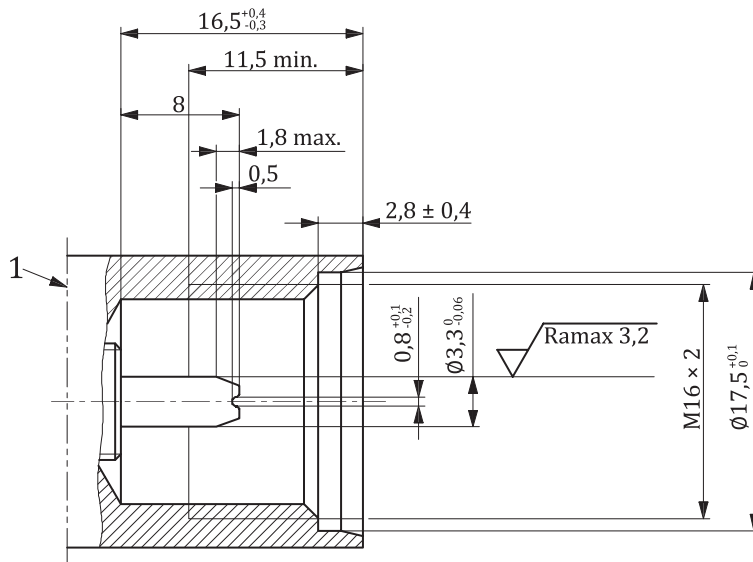

Key

- 1 design at the discretion of the manufacturer

NOTE Dimensions are in millimetres while surface roughness is in micrometres.

Figure 2 — Dimensions for diagnostic coupling counterpart

5.2 Diagnostic coupling with a stud end ISO 6149-2, M14 × 1,5

5.2.1 The dimensions for a diagnostic coupling with an M14 × 1,5 stud end in accordance with ISO 6149-2, designated as FM 14 × 1,5, are shown in [Figure 3](#).

Dimensions in millimetres

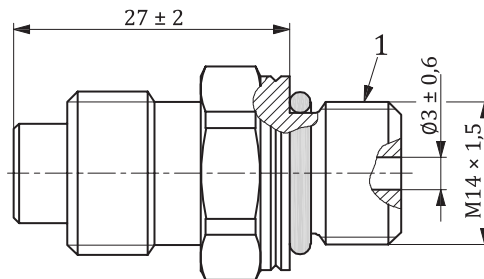

Key

1 stud end and O-ring in accordance with ISO 6149-2

Figure 3 — Diagnostic coupling with a stud end FM 14 × 1,5

5.2.2 Unless otherwise agreed upon between the supplier and the purchaser, the delivery includes the protection cap and the seal on the stud end.

5.3 Diagnostic coupling with a stud end ISO 9974-2, M14 × 1,5

5.3.1 The dimensions for a diagnostic coupling with an M14 × 1,5 stud end in accordance with ISO 9974-2, designated as EM 14 × 1,5, are shown in [Figure 4](#).

Dimensions in millimetres

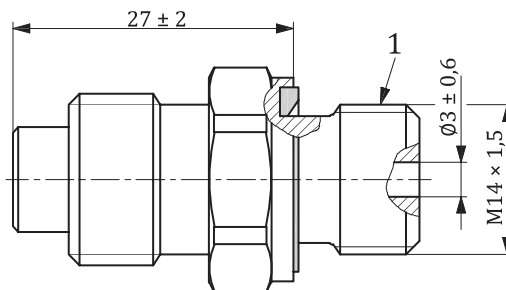

Key

1 stud end and elastomeric seal in accordance with ISO 9974-2

Figure 4 — Diagnostic coupling with a stud end EM 14 × 1,5

5.3.2 Unless otherwise agreed upon between the supplier and the purchaser, the delivery includes the protection cap and the seal on the stud end.

5.4 Diagnostic coupling with a stud end ISO 1179-2, G1/4

5.4.1 The dimensions for a diagnostic coupling with a G1/4 stud end in accordance with ISO 1179-2, designated as EG 1/4, are shown in [Figure 5](#).

Dimensions in millimetres

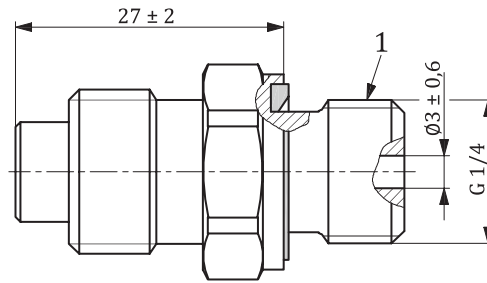

Key

1 stud end and elastomeric seal in accordance with ISO 1179-2

Figure 5 — Diagnostic coupling with a stud end EG 1/4

5.4.2 Unless otherwise agreed upon between the supplier and the purchaser, the delivery includes the protection cap and the seal on the stud end.

5.5 Diagnostic coupling with a stud end ISO 11926-2, 7/16-20 UNF

5.5.1 The dimensions for a diagnostic coupling with a 7/16-20 UNF stud end in accordance with ISO 11926-2, designated as FU 7/16-20, are shown in [Figure 6](#).

Dimensions in millimetres

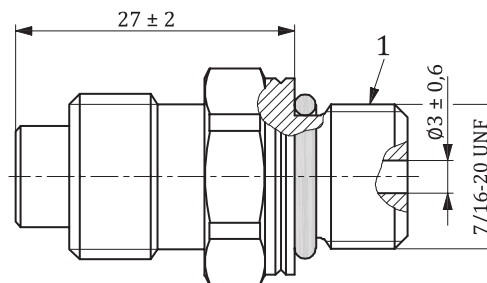

Key

1 stud end and O-ring in accordance with ISO 11926-2

Figure 6 — Diagnostic coupling with a stud end FU 7/16-20

5.5.2 Unless otherwise agreed upon between the supplier and the purchaser, the delivery includes the protection cap and the seal on the stud end.

6 Manufacture

6.1 Construction

Couplings may be made by forging or be machined from bar stock.

6.2 Workmanship

Workmanship shall conform to the best commercial practice to produce high-quality parts. Couplings shall be free from visual contaminants, all hanging burrs, loose scale and slivers that might be dislodged in use, and any other defects that might affect the functioning of the parts. Unless otherwise specified, surface finish on all surfaces shall be $R_a \leq 6,3 \mu\text{m}$.

6.3 Finish

The external surface and threads of all carbon steel parts shall be plated or coated with a suitable material that passes a 72 h neutral salt spray test in accordance with ISO 9227, unless otherwise agreed upon by the manufacturer and the user. Any appearance of red rust during the salt spray test on any area, except those noted below, shall be considered failure:

- all internal fluid passages;
- edges, such as hex points, serrations and crests of threads, where there can be mechanical deformation of the plating or coating typical of mass-produced parts or shipping effects;
- areas where there is mechanical deformation of the plating or coating caused by crimping, flaring, bending and other post-plate metal-forming operations;
- areas where the parts are suspended or affixed in the test chamber where condensate can accumulate.

Internal fluid passages shall be protected from corrosion during storage.

Cadmium plating is not allowed because of environmental concerns. Parts manufactured in accordance with this part of ISO 15171 shall not be cadmium plated. Hexavalent chromate coatings are not preferred because of environmental concerns. Changes in plating can affect assembly torques and require requalification, when applicable.

7 Designation of couplings

When ordering couplings conforming to this part of ISO 15171 a designation consisting of the words “Diagnostic coupling”, followed by the number of this part of ISO 15171, followed by a spaced hyphen, followed by the specific coupling style letter symbol designation given in [Clause 5](#), followed by a spaced hyphen, followed by the material designation, in accordance with ISO 1629, of the required sealing of the stud end, shall be used.

EXAMPLE Diagnostic coupling ISO 15171-2 - FM 14 × 1,5 - NBR

8 Marking

Couplings shall be permanently marked with the manufacturer’s name or trademark.

9 Identification statement (reference to this part of ISO 15171)

Use the following statement in test reports, catalogues, and sales literature when electing to comply with this part of ISO 15171:

“Coupling for diagnostic purposes in accordance with ISO 15171-2:2016, *Connections for fluid power and general use — Hydraulic coupling for diagnostic purposes — Part 2: Coupling with M16 × 2 end for connection under pressure.*”

Annex A

(informative)

Other hydraulic connection types suitable for diagnostic couplings

A.1 General

Currently, there are several other types of connections used for diagnostic couplings in hydraulic applications worldwide.

A non-exhaustive selection of the most common connection types is listed in the following. The specific design and dimensions of these types of diagnostic couplings are not part of this part of ISO 15171, and their use is subject to agreement between customer and manufacturer.

A.2 Diagnostic couplings with straight union connectors

- Diagnostic couplings with straight union 24° cone connector assembly in accordance with ISO 8434-1.
- Diagnostic couplings with straight union 37° flared connector in accordance with ISO 8434-2.
- Diagnostic couplings with straight union O-ring face seal connector in accordance with ISO 8434-3.

A.3 Diagnostic couplings with swivel connector ends

- Diagnostic couplings with 24° O-ring seal cone connector end in accordance with ISO 8434-1.
- Diagnostic couplings with 37° flared connector end in accordance with ISO 8434-2.
- Diagnostic couplings with O-ring face seal connector end in accordance with ISO 8434-3.

Bibliography

- [1] ISO 1179-1, *Connections for general use and fluid power — Ports and stud ends with ISO 228-1 threads with elastomeric or metal-to-metal sealing — Part 1: Threaded ports*
- [2] ISO 6149-1, *Connections for hydraulic fluid power and general use — Ports and stud ends with ISO 261 metric threads and O-ring sealing — Part 1: Ports with truncated housing for O-ring seal*
- [3] ISO 9974-1, *Connections for general use and fluid power — Ports and stud ends with ISO 261 threads with elastomeric or metal-to-metal sealing — Part 1: Threaded ports*
- [4] ISO 11926-1, *Connections for general use and fluid power — Ports and stud ends with ISO 725 threads and O-ring sealing — Part 1: Ports with O-ring seal in truncated housing*

