**Connections for fluid power and general
use — Hydraulic couplings for diagnostic
purposes —**

Part 1:
Coupling not for connection under pressure

*Raccordements pour transmissions hydrauliques et pneumatiques et usage
général — Raccords hydrauliques pour diagnostics —*

Partie 1: Raccord pour connexion n'étant pas sous pression



Foreword

ISO (the International Organization for Standardization) is a worldwide federation of national standards bodies (ISO member bodies). The work of preparing International Standards is normally carried out through ISO technical committees. Each member body interested in a subject for which a technical committee has been established has the right to be represented on that committee. International organizations, governmental and non-governmental, in liaison with ISO, also take part in the work. ISO collaborates closely with the International Electrotechnical Commission (IEC) on all matters of electrotechnical standardization.

International Standards are drafted in accordance with the rules given in the ISO/IEC Directives, Part 3.

Draft International Standards adopted by the technical committees are circulated to the member bodies for voting. Publication as an International Standard requires approval by at least 75 % of the member bodies casting a vote.

International Standard ISO 15171-1 was prepared by Technical Committee ISO/TC 131, *Fluid power systems*, Subcommittee SC 4, *Connectors and similar products and components*.

ISO 15171 consists of the following parts, under the general title *Connections for fluid power and general use — Hydraulic couplings for diagnostic purposes*:

- *Part 1: Coupling not for connection under pressure*
- *Part 2: Coupling with M16 × 2 end for connection under pressure*

© ISO 1999

All rights reserved. Unless otherwise specified, no part of this publication may be reproduced or utilized in any form or by any means, electronic or mechanical, including photocopying and microfilm, without permission in writing from the publisher.

International Organization for Standardization
Case postale 56 • CH-1211 Genève 20 • Switzerland
Internet iso@iso.ch

Printed in Switzerland

Introduction

In hydraulic fluid power systems, power is transmitted and controlled through a liquid under pressure within an enclosed circuit. In general applications, a fluid may be conveyed under pressure.

Components are equipped with ports providing diagnostic points in a hydraulic system. Diagnostic couplings may be installed to aid in the diagnosis of hydraulic systems.

Connections for fluid power and general use — Hydraulic couplings for diagnostic purposes —

Part 1: Coupling not for connection under pressure

1 Scope

This part of ISO 15171 specifies dimensions, performance requirements and test procedures for the male quick-action half of a metric coupling with an M14 × 1,5 straight stud end to mate with an ISO 6149-1 port, to be used for diagnostic purposes. Couplings in accordance with this part of ISO 15171 are not designed to connect under pressure. The coupling is designed for use in hydraulic systems that use mineral oil.

NOTE Use of this coupling with fluids other than mineral oil requires agreement between the supplier and the purchaser.

This part of ISO 15171 does not apply to the female half of the mating hydraulic quick-action coupling, which is not on the machine.

Couplings in accordance with this part of ISO 15171 may be used at a maximum working pressure of 40 MPa [400 bar¹⁾]. The permissible working pressure depends upon the materials, design, working conditions, application, etc.

Conformance to the dimensional information in this part of ISO 15171 does not guarantee rated performance. Each manufacturer should perform testing in accordance with the specification contained in this part of ISO 15171 to assure that components comply with the performance rating.

2 Normative references

The following normative documents contain certain provisions which, through reference in this text, constitute provisions of this part of ISO 15171. For dated references, subsequent amendments to, or revisions of, any of these publications do not apply. However, parties to agreements based on this part of ISO 15171 are encouraged to investigate the possibility of applying the most recent editions of the normative documents indicated below. For undated references, the latest edition of the normative document referred to applies. Members of ISO and IEC maintain registers of currently valid International Standards.

ISO 1629:1995, *Rubber and latices — Nomenclature*.

ISO 5598:1985, *Fluid power systems and components — Vocabulary*.

ISO 6149-1:—²⁾, *Connections for fluid power and general use — Ports and stud ends with ISO 261 threads and O-ring sealing — Part 1: Port with O-ring seal in truncated housing*.

¹⁾ 1 bar = 0,1 MPa = 10⁵ Pa; 1 Pa = 1 N/m²

²⁾ To be published. (Revision of ISO 6149-1:1993)

ISO 6149-2:—³⁾, *Connections for fluid power and general use — Ports and stud ends with ISO 261 threads and O-ring sealing — Part 2: Dimensions, design, test methods and requirements for heavy-duty (S series) stud ends.*

ISO 8434-5:1995, *Metallic tube connections for fluid power and general use — Part 5: Test methods for threaded hydraulic fluid power connections.*

ISO 9227:1990, *Corrosion tests in artificial atmospheres — Salt spray tests.*

3 Terms and definitions

For the purposes of this part of ISO 15171, the terms and definitions given in ISO 5598 and the following apply.

3.1 quick-action

joining of two components in a fashion with only hands and without wrenches and other mechanical means

4 Performance requirements

4.1 Working pressure and temperature

Couplings shall be designed for use at a maximum working pressure of 40 MPa (400 bar) within a temperature range between $-20\text{ }^{\circ}\text{C}$ and $+120\text{ }^{\circ}\text{C}$.

NOTE The temperature range of couplings with elastomeric seals depends on the limits of the temperature range of the seals.

4.2 Rated flow

The coupling shall be rated to handle a flow of 3 l/min at a maximum pressure drop of 500 kPa (5 bar), with a maximum rated flow without malfunction of 15 l/min.

4.3 Burst and cyclic endurance (impulse) pressures

The male half of the coupling shall meet at least a burst pressure of 160 MPa (1 600 bar) and a cyclic endurance (impulse) pressure of 53,2 MPa (532 bar) when tested in accordance with 4.4.

4.4 Test methods

Testing shall be conducted in accordance with ISO 8434-5 for burst, cyclic endurance (impulse) and vacuum. The test samples shall be tightened to the torque requirement given in ISO 6149-2 for the $M14 \times 1,5$ size stud end. After the cyclic endurance test, it shall be possible to connect and disconnect the coupling with the female half without leakage, binding or malfunction. Test results shall be reported using the form given in ISO 8434-5.

5 Design

Design and dimensions shall conform to those given in Figure 1. Stud end and O-ring shall be in accordance with ISO 6149-2.

Unless otherwise agreed upon between the supplier and purchaser, seals for stud ends shall be included in the delivery.

³⁾ To be published. (Revision of ISO 6149-2:1993)

6 Manufacture

6.1 Construction

Couplings may be made by forging or cold forming, or be machined from bar stock.

6.2 Workmanship

Workmanship shall conform to the best commercial practice to produce high-quality parts. Couplings shall be free from visual contaminants, all hanging burrs, loose scale and slivers that might be dislodged in use, and any other defects that might affect the functioning of the parts. Unless otherwise specified, surface finish on all surfaces shall be $Ra \leq 6,3 \mu\text{m}$.

6.3 Finish

The external surface and threads on all couplings shall pass a minimum 72-h salt spray test in accordance with ISO 9227, unless otherwise agreed upon by the manufacturer and the user. Any appearance of red rust during the salt spray test shall be considered failure. Fluid passages shall be excluded from plating or coating requirements but shall be protected with a rust inhibitor.

Corrosion protection requirements do not apply to corners or edges such as hex points, serrations and the crests of threads.

7 Designation of couplings

When ordering couplings conforming to this part of ISO 15171, a designation consisting of the number of this part of ISO 15171, followed by a spaced hyphen, followed by the material designation, in accordance with ISO 1629, of the required sealing of the stud end, shall be used.

EXAMPLE **ISO 15171-1 - NBR**

8 Marking

Couplings shall be permanently marked with the manufacturer's name or trademark.

9 Identification statement (reference to this part of ISO 15171)

Use the following statement in test reports, catalogues and sales literature when electing to comply with this part of ISO 15171:

“Coupling for diagnostic purposes in accordance with ISO 15171-1:1999, *Connections for fluid power and general use — Hydraulic couplings for diagnostic purposes — Part 1: Coupling not for connection under pressure.*”

.....

Dimensions in millimetres

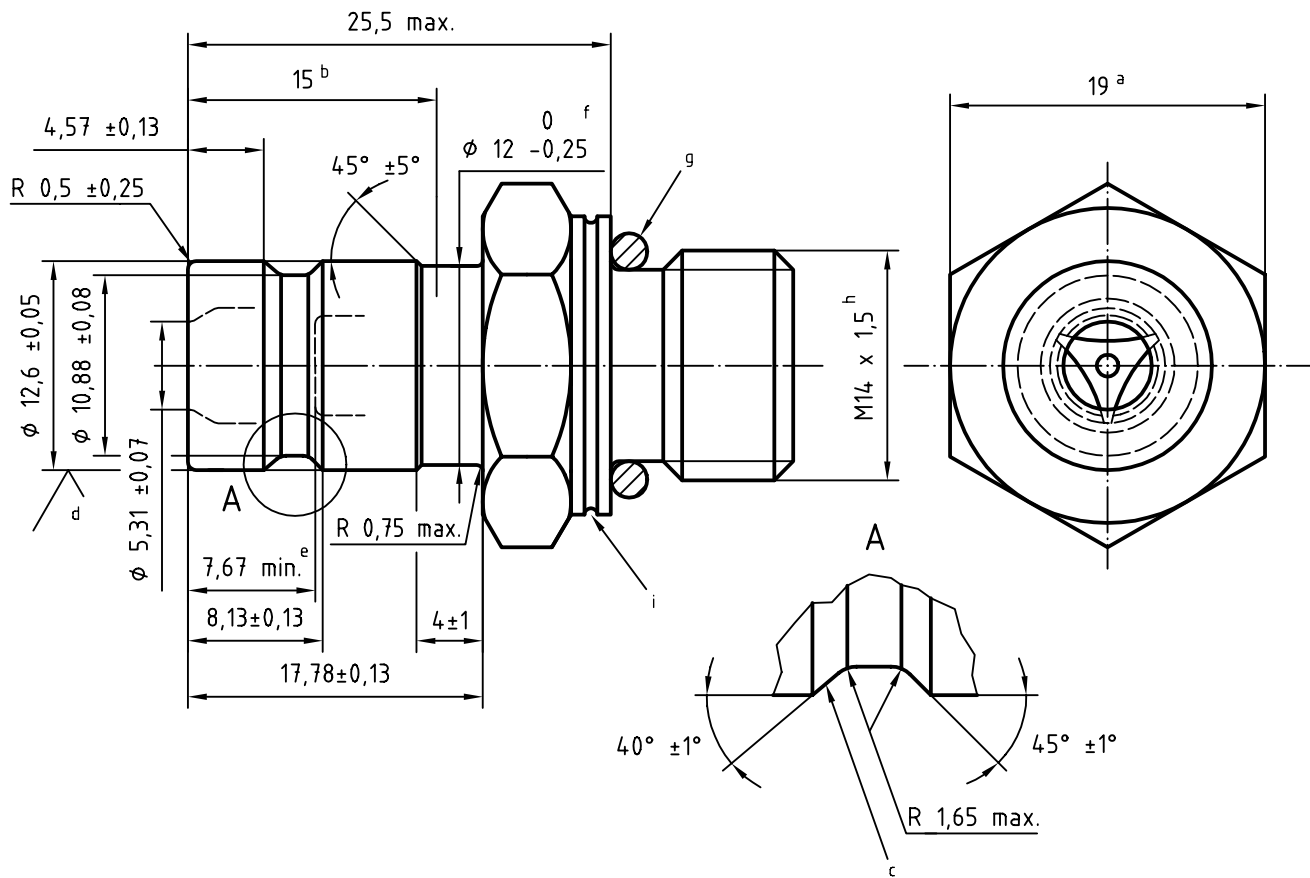

- a Width across flats
- b Maximum engagement
- c Hardness 42 HRC to 55 HRC in contact area
- d $Ra \leq 2,5 \mu\text{m}$ for 4,57 mm length
- e Valve open
- f This groove is for product marking and attachment of protective cap. Alternate marking location is on hex flats.
- g O-ring
- h Stud end in accordance with ISO 6149-2
- i Identification groove in accordance with ISO 6149-2

Figure 1 — Dimensions and tolerances of male half of diagnostic coupling

ICS 23.100.40

Price based on 4 pages
