

---

---

**Plastics — Film and sheeting —  
Determination of water vapour  
transmission rate —**

**Part 6:  
Atmospheric pressure ionization mass  
spectrometer method**

*Plastiques — Film et feuille — Détermination du coefficient de  
transmission de vapeur d'eau —*

*Partie 6: Méthode utilisant un spectromètre de masse à ionisation  
sous pression atmosphérique*



**COPYRIGHT PROTECTED DOCUMENT**

© ISO 2015

All rights reserved. Unless otherwise specified, no part of this publication may be reproduced or utilized otherwise in any form or by any means, electronic or mechanical, including photocopying, or posting on the internet or an intranet, without prior written permission. Permission can be requested from either ISO at the address below or ISO's member body in the country of the requester.

ISO copyright office  
Case postale 56 • CH-1211 Geneva 20  
Tel. + 41 22 749 01 11  
Fax + 41 22 749 09 47  
E-mail [copyright@iso.org](mailto:copyright@iso.org)  
Web [www.iso.org](http://www.iso.org)

Published in Switzerland

# Contents

	Page
Foreword .....	iv
<b>1 Scope .....</b>	<b>1</b>
<b>2 Normative references .....</b>	<b>1</b>
<b>3 Terms and definitions .....</b>	<b>1</b>
<b>4 Principle .....</b>	<b>1</b>
<b>5 Test specimens .....</b>	<b>2</b>
<b>6 Conditioning .....</b>	<b>2</b>
<b>7 Apparatus .....</b>	<b>2</b>
<b>8 Test condition .....</b>	<b>3</b>
<b>9 Calibration graph .....</b>	<b>4</b>
<b>10 Procedure .....</b>	<b>5</b>
<b>11 Calculation .....</b>	<b>6</b>
<b>12 Test result .....</b>	<b>6</b>
<b>13 Precision .....</b>	<b>6</b>
<b>14 Test report .....</b>	<b>6</b>
<b>Bibliography .....</b>	<b>8</b>

## Foreword

ISO (the International Organization for Standardization) is a worldwide federation of national standards bodies (ISO member bodies). The work of preparing International Standards is normally carried out through ISO technical committees. Each member body interested in a subject for which a technical committee has been established has the right to be represented on that committee. International organizations, governmental and non-governmental, in liaison with ISO, also take part in the work. ISO collaborates closely with the International Electrotechnical Commission (IEC) on all matters of electrotechnical standardization.

The procedures used to develop this document and those intended for its further maintenance are described in the ISO/IEC Directives, Part 1. In particular the different approval criteria needed for the different types of ISO documents should be noted. This document was drafted in accordance with the editorial rules of the ISO/IEC Directives, Part 2 (see [www.iso.org/directives](http://www.iso.org/directives)).

Attention is drawn to the possibility that some of the elements of this document may be the subject of patent rights. ISO shall not be held responsible for identifying any or all such patent rights. Details of any patent rights identified during the development of the document will be in the Introduction and/or on the ISO list of patent declarations received (see [www.iso.org/patents](http://www.iso.org/patents)).

Any trade name used in this document is information given for the convenience of users and does not constitute an endorsement.

For an explanation on the meaning of ISO specific terms and expressions related to conformity assessment, as well as information about ISO's adherence to the WTO principles in the Technical Barriers to Trade (TBT) see the following URL: [Foreword - Supplementary information](#)

The committee responsible for this document is ISO/TC 61, *Plastics*, Subcommittee SC 11, *Products*.

ISO 15106 consists of the following parts, under the general title *Plastics — Film and sheeting — Determination of water vapour transmission rate*:

- *Part 1: Humidity detection sensor method*
- *Part 2: Infrared detection sensor method*
- *Part 3: Electrolytic detection sensor method*
- *Part 4: Gas-chromatographic detection sensor method*
- *Part 5: Pressure sensor method*
- *Part 6: Atmospheric pressure ionization mass spectrometer method*
- *Part 7: Calcium corrosion method*

# Plastics — Film and sheeting — Determination of water vapour transmission rate —

## Part 6: Atmospheric pressure ionization mass spectrometer method

### 1 Scope

This part of ISO 15106 specifies a method for determining the water vapour transmission rate of plastic film, plastic sheeting, and multi-layer structures including plastics, using an atmospheric pressure ionization mass spectrometric detection sensor.

NOTE The method provides rapid measurement over a wide range of water vapour transmission rates.

### 2 Normative references

The following documents, in whole or in part, are normatively referenced in this document and are indispensable for its application. For dated references, only the edition cited applies. For undated references, the latest edition of the referenced document (including any amendments) applies.

ISO 6145-8, *Gas analysis — Preparation of calibration gas mixtures using dynamic volumetric methods — Part 8: Diffusion method*

### 3 Terms and definitions

For the purposes of this document, the following terms and definitions apply.

#### 3.1

##### **water vapour transmission rate**

amount of water vapour transmitted through unit area of test specimen per unit time under specified conditions

Note 1 to entry: Water vapour transmission rate is expressed in grams per square metre per 24 h [ $\text{g}/(\text{m}^2 \cdot 24 \text{ h})$ ].

### 4 Principle

The gas transmission cell is designed in such a way that, with the test specimen inserted, it is divided into a dry chamber and a wet chamber. The dry side of the specimen is swept by a flow of dry carrier gas such as nitrogen or argon, and water vapour permeating through the specimen from the wet chamber is carried by the carrier gas into an atmospheric pressure ionization mass spectrometer. This sensor contains an ion formation region near atmospheric pressure and a mass analysis region in ultra-high vacuum. The carrier gas with the moisture is introduced into the ion formation region where the carrier gas is ionized as primary ions by corona discharge ion sources, and then, an ion-molecule reaction is produced between the primary ions and water molecules contained in the carrier gas and the water molecules are ionized. These ionized water molecules are fed to the mass analysis region. Water vapour content in the range between ppt and ppb in the carrier gas can be detected as an ion intensity of mass number ( $m/z$ ) of ion species, such as  $\text{H}_2\text{O}^+$  at  $m/z$  18,  $\text{H}_3\text{O}^+$  at  $m/z$  19, and  $\text{H}^+(\text{H}_2\text{O})_2$  at  $m/z$  37. These are produced by ionization of water in the ion source and determined using a calibration curve. The mass of the water vapour which permeates through the specimen per unit time is calculated from the ion intensity of the water molecules.

## 5 Test specimens

**5.1** The specimens shall be representative of the material, be free from wrinkles, creases, and pinholes, and have uniform thickness. Each specimen shall have a larger area than the transmission area of the cell used for the test.

**5.2** Three specimens shall be tested unless otherwise specified or agreed between the interested parties.

NOTE For some products, testing more than three specimens gives a more representative result.

## 6 Conditioning

Condition the specimens at  $23\text{ °C} \pm 2\text{ °C}$  in a desiccator to prevent moisture uptake. The period of conditioning shall be as stated in the relevant specification for the material.

NOTE For some products, heating the test specimen is effective for rapid conditioning.

## 7 Apparatus

**7.1** An example of a suitable apparatus is shown in [Figure 1](#). The apparatus includes a transmission cell with two chambers, a dry chamber and a wet chamber between which a specimen is mounted, an atmospheric pressure ionization mass spectrometer to determine the amount of water vapour transmitted, two flow controllers, a getter (for example, a molecular sieve), and a humidity controller (water reservoir).

**7.2** The diameter of the water vapour transmission area shall typically be 5 mm to 200 mm. The temperature of the transmission cell shall be kept within  $\pm 0,5\text{ °C}$  of the test temperature by means of a temperature controller.

The size of non-circular samples shall be agreed upon by the interested parties.

**7.3** The flow controller shall be capable of regulating the flow rates of the carrier gas from 500 ml to 1 000 ml per minute.

**7.4** The getter shall be capable of reducing the moisture contents below 1 ppb.

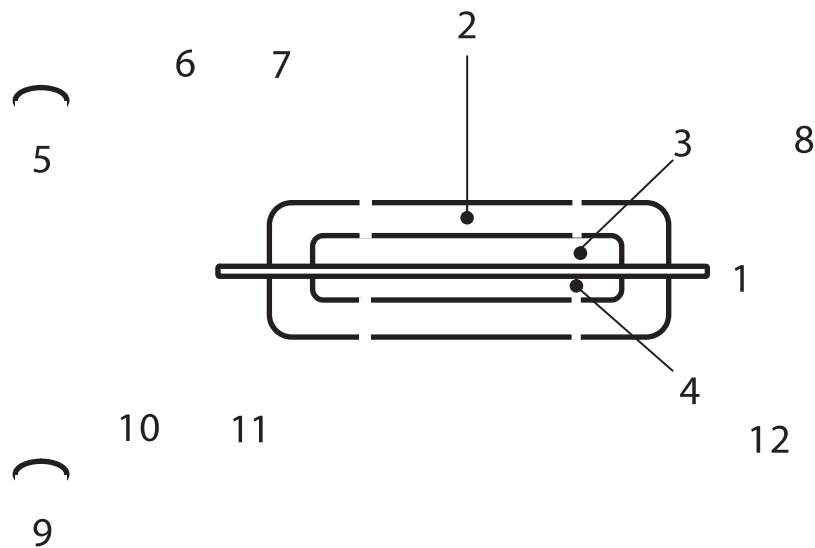
**Key**

1	test specimen	7	getter (for example, a molecular sieve)
2	transmission cell	8	atmospheric pressure ionization mass spectrometer
3	dry chamber	9	gas supply
4	wet chamber	10	mass flow controller
5	gas supply	11	humidity controller with distilled or deionized water (water reservoir)
6	mass flow controller	12	gas exhaust

**Figure 1 — Example of water vapour transmission rate measuring apparatus with atmospheric pressure ionization mass spectrometric detection sensor**

### 7.5 Atmospheric pressure ionization mass spectrometer

The atmospheric pressure ionization mass spectrometer shall be able to measure the ion intensity of ion species, such as  $\text{H}_2\text{O}^+$  at  $m/z$  18,  $\text{H}_3\text{O}^+$  at  $m/z$  19, and  $\text{H}^+(\text{H}_2\text{O})_2$  at  $m/z$  37 with an accuracy of at least 0,01 parts per billion by volume.

### 7.6 Gas flow controller

The gas flow controller shall be capable of maintaining the gas flow to the carrier gas passed through the dry and wet chambers and the humidity controller at a constant rate.

The recommended flow rate is between 500 ml/min and 1 000 ml/min.

### 7.7 Humidity controller (water reservoir)

A humidity controller that contains distilled or deionized water is connected to the wet chamber. The temperature of the water in the reservoir shall be kept at the temperature of the transmission cell (see [Table 1](#)). Gas shall be supplied to the humidity controller through the gas flow controller. The gas is bubbled through the water in the reservoir and becomes saturated with water vapour at the given temperature.

## 8 Test condition

The test conditions should preferably be chosen from those given in [Table 1](#).

**Table 1 — Choice of test conditions**

Test conditions	Temperature	Relative humidity
	°C	%
1	25 ± 0,5	90 ± 3
2	40 ± 0,5	90 ± 3
3	60 ± 0,5	90 ± 3
4	85 ± 0,5	85 ± 3

Test conditions other than these shall be agreed upon by the interested parties.

## 9 Calibration graph

**9.1** Prepare a low-level humidity standard in accordance with ISO 6145-8 (diffusion method) or by another suitable method.

For example, in order to obtain a range of water vapour concentration between ppt and ppb for the calibration gas, the standard moisture is diluted over  $10^4$  times as shown in [Figure 2](#) using a two stage dilution method. A small amount of water vapour from the humidity standard is diluted by controlling the two large volumes of dry gas by MFC1 and MFC2 to obtain the calibration gas with a lower water vapour content.

**9.2** Inject the calibration gas with a known trace level humidity into the atmospheric pressure ionization mass spectrometer and record the relative ion intensity expressed as ratio of water ion intensity to total ion intensity. In the atmospheric pressure ionization mass spectrometer analysis, water is observed in the form of several ion species, such as  $\text{H}_2\text{O}^+$  at  $m/z$  18,  $\text{H}_3\text{O}^+$  at  $m/z$  19, and  $\text{H}^+(\text{H}_2\text{O})_2$  at  $m/z$  37. The water ion intensity is obtained by the sum of the ion intensities of those three different ion species. Produce a calibration graph by plotting the moisture content against the water ion intensity.



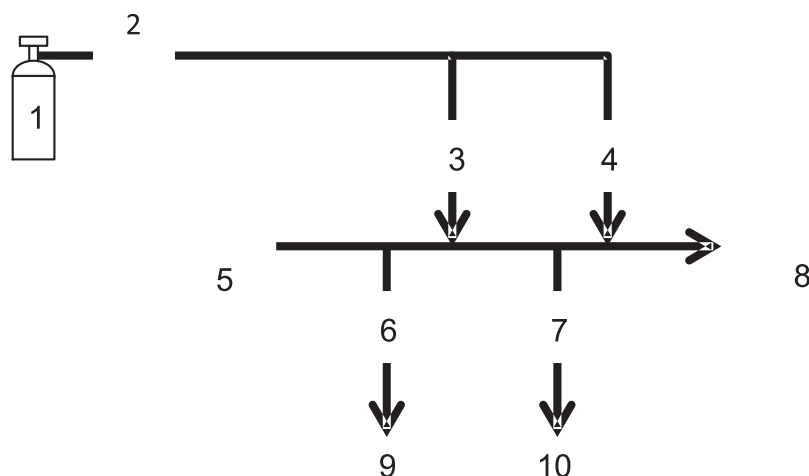

### Key

- 1 gas supply
- 2 getter (for example, a molecular sieve)
- 3 mass flow controller for dilution (MFC1)
- 4 mass flow controller for dilution (MFC2)
- 5 generation chamber
- 6 mass flow controller for evacuation (MFC3)
- 7 mass flow controller for evacuation (MFC4)
- 8 atmospheric pressure ionization mass spectrometric detection sensor
- 9 gas exhaust
- 10 gas exhaust

**Figure 2 — Example of a two stage dilution method for calibration gas with controlled water content in the ppm-ppt range**

## 10 Procedure

**10.1** Measure the water vapour transmission rate of each specimen as described in [10.2](#) to [10.6](#).

**10.2** Place the specimen between the dry and wet chambers (see [Figure 1](#)), and close the transmission cell to give a hermetically sealed assembly.

**10.3** Sweep the carrier gas at the specified flow rate through the dry and wet chambers to remove all the moisture from both chambers. Care is necessary, because the time it takes to exhaust the cell completely might depend on the permeability of the specimen under test.

The flow rate should be specified by the manufacturer of the apparatus.

**10.4** Inject the carrier gas passed through the dry chamber into the atmospheric pressure ionization mass spectrometer. Determine the water ion intensity of ion species, such as  $\text{H}_2\text{O}^+$  at  $m/z$  18,  $\text{H}_3\text{O}^+$  at  $m/z$  19, and  $\text{H}^+(\text{H}_2\text{O})_2$  at  $m/z$  37 corresponding to water vapour. When the ion intensity remains constant, indicating that the leakages of water to the carrier gas from the outside of the water vapour permeation apparatus have minimized, determine from the calibration graph prepared in [Clause 9](#) the concentration of water vapour  $C_0$  in the carrier gas passed through the dry chamber.

**10.5** Introduce water vapour into the wet chamber through the humidity controller in such a way that the wet chamber is kept at constant humidity. Water vapour permeating from the wet chamber to the dry chamber through the specimen is swept by the carrier gas into atmospheric pressure ionization mass spectrometric detection sensor.

**10.6** Monitor the water ion intensity of ion species such as  $\text{H}_2\text{O}^+$  at  $m/z$  18,  $\text{H}_3\text{O}^+$  at  $m/z$  19, and  $\text{H}^+(\text{H}_2\text{O})_2$  at  $m/z$  37, from the atmospheric pressure ionization mass spectrometer until it reaches steady state. Determine the concentration of water vapour  $C_f$  from the calibration graph prepared in [Clause 9](#).

## 11 Calculation

Calculate the water vapour transmission rate of each test specimen using Formula (1):

$$\text{WVTR} = \frac{M_W \times F \times (C_f - C_0)}{22,4 \times A} \quad (1)$$

where

WVTR	is the water vapour transmission rate of the test specimen, expressed in grams per square metre per 24 h [g/(m <sup>2</sup> ·24 h)];	mark
$F$	is the flow rate of the carrier gas reduced at 1 atm and 0°C [litre/day];	
$C_0$	is the amount fraction of the water vapour in the carrier gas passed through the dry chamber before humidification in the dry chamber [mol/mol] (for example, 1 ppb = 10 <sup>-9</sup> );	
$C_f$	is the amount fraction of the water vapour in the carrier gas passed through the dry chamber at steady state measured with the test specimen [mol/mol] (for example, 1 ppb = 10 <sup>-9</sup> );	
$A$	is the transmission area of the test specimen, in square metres;	
$M_W$	is the molecular weight of water (= 18,0) [g/mol].	

## 12 Test result

Calculate the test result as the arithmetic mean of the results obtained for each test specimen, rounding to two significant figures.

## 13 Precision

The precision of this test method is not known because interlaboratory data are not available. When interlaboratory data are obtained, a precision statement will be added at the following revision.

## 14 Test report

The test report shall include the following information:

- a reference to this part of ISO 15106, i.e. ISO 15106-6;
- the name of the apparatus used;
- the test conditions;
- all details necessary for identification of the sample tested;

- e) the method of preparation of the test specimens;
- f) the side of the test specimen which faced the supply of water vapour;
- g) the transmission area of the test specimen;
- h) the mean thickness of the specimen;
- i) the number of specimens tested;
- j) details of specimen conditioning;
- k) the test result;
- l) the date of the test.

## Bibliography

- [1] ISO 4593:1993, *Plastics — Film and sheeting — Determination of thickness by mechanical scanning*



