**Multiple split-system air-conditioners and
air-to-air heat pumps — Testing and
rating for performance**

*Climatiseurs et pompes à chaleur air/air multi-split — Essais et
détermination des caractéristiques de performance*



Reference number
ISO 15042:2011(E)

© ISO 2011



COPYRIGHT PROTECTED DOCUMENT

© ISO 2011

All rights reserved. Unless otherwise specified, no part of this publication may be reproduced or utilized in any form or by any means, electronic or mechanical, including photocopying and microfilm, without permission in writing from either ISO at the address below or ISO's member body in the country of the requester.

ISO copyright office
Case postale 56 • CH-1211 Geneva 20
Tel. + 41 22 749 01 11
Fax + 41 22 749 09 47
E-mail copyright@iso.org
Web www.iso.org

Published in Switzerland

Contents

Page

Foreword	v
1 Scope	1
2 Normative references	1
3 Terms and definitions	2
4 Symbols	4
5 Airflow setting	7
5.1 General	7
5.2 Airflow setting for ducted indoor units	7
5.3 ESP for rating	8
5.4 Airflow setting for non-ducted indoor units measured by air-enthalpy method	10
5.5 Outdoor airflow	10
5.6 Unit supplied without indoor fan	10
6 Cooling tests	10
6.1 Cooling capacity test	10
6.2 Maximum cooling performance test	13
6.3 Minimum cooling test	14
6.4 Freeze-up drip test (applies to non-ducted multi-splits)	15
6.5 Condensate control test and enclosure sweat test	16
7 Heating tests	18
7.1 Heating capacity tests	18
7.2 Maximum heating performance test	23
7.3 Minimum heating performance test	24
7.4 Automatic defrost test	25
8 Heat recovery test	26
8.1 Heat recovery capacity ratings	26
9 Test methods and uncertainties of measurement	26
9.1 Test methods	26
9.2 Uncertainty of measurement	27
9.3 Test tolerances for the capacity tests	28
9.4 Test tolerances for performance tests	29
10 Test results	29
10.1 Capacity calculations	29
10.2 Data to be recorded	31
10.3 Test report	33
11 Marking provisions	34
11.1 Nameplate requirements	34
11.2 Nameplate information	34
11.3 Additional information	34
12 Publication of ratings	34
12.1 Standard ratings	34
12.2 Other ratings	34
Annex A (normative) Airflow settings for ducted units	35
Annex B (normative) Test requirements	39
Annex C (informative) Airflow measurement	45

Annex D (normative) Calorimeter test method	51
Annex E (normative) Indoor air enthalpy test method	60
Annex F (informative) Part-load capacity tests and determination of energy efficiency ratios and coefficients of performance.....	66
Annex G (informative) Individual indoor unit capacity tests	67
Annex H (normative) Heat recovery test method.....	69
Annex I (informative) Compressor calibration test method.....	70
Annex J (informative) Refrigerant enthalpy test method	73
Annex K (informative) Outdoor air enthalpy test method	75
Annex L (informative) Indoor calorimeter confirmative test method.....	78
Annex M (informative) Outdoor calorimeter confirmative test method.....	80
Annex N (informative) Balanced-type calorimeter confirmative test method	82
Annex O (informative) Cooling condensate measurements	83
Annex P (normative) Supplemental requirements when rating fan-less (coil only) type units	84
Annex Q (informative) Pictorial examples of the heating capacity test procedures given in 7.1	87
Bibliography	94

Foreword

ISO (the International Organization for Standardization) is a worldwide federation of national standards bodies (ISO member bodies). The work of preparing International Standards is normally carried out through ISO technical committees. Each member body interested in a subject for which a technical committee has been established has the right to be represented on that committee. International organizations, governmental and non-governmental, in liaison with ISO, also take part in the work. ISO collaborates closely with the International Electrotechnical Commission (IEC) on all matters of electrotechnical standardization.

International Standards are drafted in accordance with the rules given in the ISO/IEC Directives, Part 2.

The main task of technical committees is to prepare International Standards. Draft International Standards adopted by the technical committees are circulated to the member bodies for voting. Publication as an International Standard requires approval by at least 75 % of the member bodies casting a vote.

Attention is drawn to the possibility that some of the elements of this document may be the subject of patent rights. ISO shall not be held responsible for identifying any or all such patent rights.

ISO 15042 was prepared by Technical Committee ISO/TC 86, *Refrigeration and air-conditioning*, Subcommittee SC 6, *Testing and rating of air-conditioners and heat pumps*.

Multiple split-system air-conditioners and air-to-air heat pumps — Testing and rating for performance

1 Scope

This International Standard establishes performance testing and rating criteria for factory-made residential, commercial and industrial, electrically driven, mechanical-compression, air-cooled air-conditioners and air-to-air heat pumps, described as basic multi-split systems, modular multi-split systems and modular heat recovery multi-split systems. These multi-split systems include air-to-air systems with non-ducted and/or ducted indoor units with integral fans and indoor units supplied without fans.

This International Standard is limited to single- and multiple-circuit split-systems which utilize one or more compressors with no more than two steps of control of the outdoor unit. It is also limited to split-systems with a single refrigeration circuit which utilize one or more variable-speed compressors or alternative compressor combinations for varying the capacity of the system by three or more steps. These split-systems are designed to operate with a combination of one or more outdoor units and two or more indoor units designed for individual operation, and such modular systems that are capable of transferring recovered heat from one or more indoor units to other units in the same system.

The requirements of testing and rating contained in this International Standard are based on the use of matched assemblies.

This International Standard is not applicable to the testing and rating of:

- a) water-cooled or water source equipment;
- b) mobile (single-duct) units having a condenser exhaust duct;
- c) individual assemblies not constituting a complete refrigeration system;
- d) equipment using the absorption refrigeration cycle.

This International Standard does not cover the determination of either seasonal efficiencies or seasonal part-load performances which can be required in some countries because they provide a better indication of efficiency under actual operating conditions.

NOTE Throughout this International Standard, the terms “equipment” and “systems” mean “multi-split air-conditioners” and/or “multi-split heat pumps”.

2 Normative references

The following referenced documents are indispensable for the application of this document. For dated references, only the edition cited applies. For undated references, the latest edition of the referenced document (including any amendments) applies.

ISO 817, *Refrigerants — Designation and safety classification*¹⁾

1) To be published. (Revision of ISO 817:2005.)

3 Terms and definitions

For the purposes of this document, the following definitions apply.

3.1

standard air

dry air at 20 °C and at a standard barometric pressure of 101,325 kPa, having a mass density of 1 204 kg/m³

3.2

full capacity

capacity of the system when all indoor units and outdoor units are operated in the same mode

3.3

latent cooling capacity **room dehumidifying capacity**

amount of latent heat that the equipment can remove from the conditioned space in a defined interval of time

NOTE Latent cooling capacity and room dehumidifying capacity are expressed in units of watts.

3.4

part-load capacity

capacity of the system when the capacity ratio is less than 1

3.5

capacity ratio

ratio of the total stated cooling capacity of all operating indoor units to the stated cooling capacity of the outdoor unit at the rating conditions

3.6

heating capacity

amount of heat that the equipment can add to the conditioned space (but not including supplementary heat) in a defined interval of time

NOTE Heating capacity is expressed in units of watts.

3.7

sensible cooling capacity

amount of sensible heat that the equipment can remove from the conditioned space in a defined interval of time

NOTE Sensible cooling capacity is expressed in units of watts.

3.8

total cooling capacity

amount of sensible and latent heat that the equipment can remove from the conditioned space in a defined interval of time

NOTE Total cooling capacity is expressed in units of watts.

3.9

energy efficiency ratio

EER

ratio of the total cooling capacity to the effective power input to the device at any given set of rating conditions

NOTE Where the EER is stated without an indication of units, it is understood that it is derived from watts/watts.

3.10
coefficient of performance
COP

ratio of the heating capacity to the effective power input to the device at any given set of rating conditions

NOTE Where the COP is stated without an indication of units, it is understood that it is derived from watts/watts.

3.11
heat recovery efficiency
HRE

ratio of the total capacity of the system (heating and cooling capacity) to the effective power when operating in the heat recovery mode

NOTE Where HRE is stated without an indication of units, it is understood that it is derived from watts/watts.

3.12
air-conditioner

an encased assembly or assemblies designed primarily to provide free or ducted delivery of conditioned air to an enclosed space room or zone (conditioned space)

NOTE It can be either single-package or split-system and comprises a primary source of refrigeration for cooling and dehumidification. It can also include means for heating other than a heat pump, as well as means for circulating, cleaning, humidifying, ventilating or exhausting air. Such equipment can be provided in more than one assembly, the separated assemblies (split-systems) of which are intended to be used together.

3.13
heat pump

an encased assembly or assemblies designed primarily to provide free or ducted delivery of conditioned air to an enclosed space, room or zone (conditioned space) and includes a prime source of refrigeration for heating

NOTE It can be constructed to remove heat from the conditioned space and discharge it to a heat sink if cooling and dehumidification are desired from the same equipment. It can also include means for circulating, cleaning, humidifying, ventilating or exhausting air. Such equipment can be provided in more than one assembly, the separated assemblies (split-systems) of which are intended to be used together.

3.14
basic multi-split system

a split-system air-conditioner or heat pump incorporating a single refrigerant circuit with one or more compressors, multiple evaporators (indoor units) designed for individual operation, and one outdoor unit

NOTE The system has no more than two steps of control and is capable of operating either as an air-conditioner or as a heat pump. Alternatively, a system having a variable speed compressor and a fixed combination of indoor units specified by the manufacturer can also be considered a basic multi-split system.

3.15
multiple-circuit multi-split system

a split-system air-conditioner or heat pump incorporating multiple refrigerant circuits, two or more compressors, multiple evaporators (indoor units) and an integrated heat exchanger in a single outdoor unit

NOTE The system has no more than two steps of control and is capable of operating either as an air-conditioner or as a heat pump.

3.16
modular multi-split system

a split-system air-conditioner or heat pump incorporating a single refrigerant circuit, at least one variable speed compressor or an alternative compressor combination for varying the capacity of the system by three or more steps, multiple indoor units, each of which can be individually controlled, and one or more outdoor units

NOTE The system is capable of operating either as an air-conditioner or as a heat pump

3.17

modular heat recovery multi-split system

split-system air-conditioner or heat pump incorporating a single refrigerant circuit, at least one variable-speed compressor or an alternate compressor combination for varying the capacity of the system by three or more steps, multiple evaporators (indoor units, each capable of being individually controlled), and one or more condensers (outdoor units)

NOTE This system is capable of operating as a heat pump where recovered heat from the indoor units operating in the cooling mode can be transferred to one or more other indoor units operating in the heating mode. Heat recovery can be achieved by a gas/liquid separator or a third line in the refrigeration circuit.

3.18

effective power input

P_E

average electrical power input to the equipment obtained from

- the power input for operation of the compressor(s),
- the power input to electric heating devices used only for defrosting,
- the power input to all control and safety devices of the equipment, and
- the power input for operation of all fans, whether provided with the equipment or not

NOTE Effective power input is expressed in units of watts.

3.19

total power input

P_t

average electrical power input to the equipment as measured during the test

NOTE Total power input is expressed in units of watts

3.20

full-load operation

operation with the equipment and controls configured for the maximum continuous duty refrigeration capacity specified by the manufacturer and allowed by the unit controls

NOTE Unless otherwise regulated by the automatic controls of the equipment, all indoor units and compressors are functioning during full-load operations.

4 Symbols

Symbol	Description	Unit
A_l	coefficient, heat leakage	J/s °C
A_n	nozzle area	m ²
α	pressure ratio	—
C_d	nozzle discharge coefficient	—
c_o	concentration of oil	—
c_{pa}	specific heat of moist air	J/kg °C
c_{pa1}	specific heat of moist air entering indoor side	J/kg °C
c_{pa2}	specific heat of moist air leaving indoor side	J/kg °C

Symbol	Description	Unit
c_{pw}	specific heat of water	J/kg °C
D_e	equivalent diameter	mm
D_n	nozzle throat diameter	mm
D_i	diameter of circular ducts, inlet	mm
D_o	diameter of circular ducts, outlet	mm
D_t	outside diameter of refrigerant tube	mm
h_{a1}	specific enthalpy of air entering indoor side	J/kg of dry air
h_{a2}	specific enthalpy of air leaving indoor side	J/kg of dry air
h_{a3}	specific enthalpy of air entering outdoor side	J/kg of dry air
h_{a4}	specific enthalpy of air leaving outdoor side	J/kg of dry air
h_{f1}	specific enthalpy of refrigerant liquid entering the expansion device	J/kg
h_{f2}	specific enthalpy of refrigerant liquid leaving condenser	J/kg
h_{g1}	specific enthalpy of refrigerant vapour entering compressor	J/kg
h_{g2}	specific enthalpy of refrigerant vapour leaving condenser	J/kg
h_{k2}	specific enthalpy of fluid leaving calorimeter evaporator	J/kg
h_{r1}	specific enthalpy of refrigerant entering indoor side	J/kg
h_{r2}	specific enthalpy of refrigerant leaving indoor side	J/kg
h_{w1}	specific enthalpy of water or steam supplied to indoor-side compartment	J/kg
h_{w2}	specific enthalpy of condensed moisture leaving indoor-side compartment	J/kg
h_{w3}	specific enthalpy of condensate removed by air-treating coil in the outdoor-side compartment of the reconditioning equipment	J/kg
h_{w4}	specific enthalpy of the water supplied to the outdoor-side compartment	J/kg
h_{w5}	specific enthalpy of, respectively, the condensed water (in the case of test condition, high) and the frost (in the case of test conditions low or extra-low) in the test unit	J/kg
K_1	latent heat of vaporization of water (2 500,4 J/g at 0 °C)	J/kg
L_d	length of duct	m
L_m	length to external static pressure measuring point	m
\ln	natural logarithm	—
m_1	mass of cylinder and bleeder assembly, empty	g
m_3	mass of cylinder and bleeder assembly with sample	g
m_5	mass of cylinder and bleeder assembly with oil from sample	g
$\eta_{fan,i}$	estimated indoor fan static efficiency	—
$\eta_{mot,i}$	estimated indoor motor efficiency	—
p_a	barometric pressure	kPa
p_c	compartment equalization pressure	kPa
p_e	external static pressure (ESP)	kPa
p_{isc}	internal static pressure drop of the indoor coil cabinet assembly measured from cooling capacity test	Pa

Symbol	Description	Unit
p_m	measured external static pressure	kPa
p_n	pressure at the nozzle throat	kPa abs
p_v	velocity pressure at nozzle throat or static pressure difference across nozzle	Pa
Re	Reynolds number	—
μ	kinematic viscosity of air	m ² /s
ϕ_{ci}	heat removed from indoor-side compartment	W
ϕ_c	heat removed by cooling coil in the outdoor-side compartment	W
ϕ_p	heat leakage into indoor-side compartment through partition separating indoor side from outdoor side	W
ϕ_i	heat leakage into indoor-side compartment through walls, floor and ceiling	W
ϕ_o	heat leakage out of outdoor-side compartment through walls, floor and ceiling	W
ϕ_L	line heat loss in interconnecting tubing	W
ϕ_e	heat input to calorimeter evaporator	W
ϕ_d	latent cooling capacity (dehumidifying)	W
ϕ_{ci}	latent cooling capacity (indoor-side data)	W
ϕ_{sc}	sensible cooling capacity	W
ϕ_{sci}	sensible cooling capacity (indoor-side data)	W
ϕ_{hi}	heating capacity (indoor-side compartment)	W
ϕ_{ho}	heating capacity (outdoor-side compartment)	W
ϕ_{ci}	total cooling capacity (indoor-side data)	W
ϕ_{tco}	total cooling capacity (outdoor-side data)	W
ϕ_{thi}	total heating capacity (indoor-side data)	W
ϕ_{tho}	total heating capacity (outdoor-side data)	W
P_{fan}	estimated fan power to circulate indoor air	W
P_i	power input (indoor-side data)	W
ΣP_{ic}	other power input to the indoor-side compartment (e.g. illumination, electrical and thermal power input to the compensating device, heat balance of the humidification device)	W
ΣP_{oc}	sum of all total power input to the outdoor-side compartment, not including power to the equipment under test	W
P_E	effective power input to the equipment	W
P_K	power input to compressor	W
P_t	total power input to equipment	W
q_m	air mass flow rate	kg/s
$q_{V,o}$	measured outdoor air volume flow	m ³ /s
q_r	refrigerant flow rate	kg/s
q_{ro}	refrigerant and oil mixture flow rate	kg/s
q_s	standard flow rate	m ³ /s
q_V	air-volume flow rate	m ³ /s

Symbol	Description	Unit
$q_{V,i}$	indoor air-volume flow rate	m ³ /s
q_w	condenser water flow rate	kg/s
q_{wc}	rate at which water vapour is condensed by the equipment	g/s
$q_{m,w}$	water mass flow supplied to the outside compartment for maintaining the test conditions	kg/s
t_a	temperature, ambient	°C
t_{a1}	temperature of air entering indoor side, dry bulb	°C
t_{a2}	temperature of air leaving indoor side, dry bulb	°C
t_{a3}	temperature of air entering outdoor side, dry bulb	°C
t_{a4}	temperature of air leaving indoor side, dry bulb	°C
t_c	temperature of surface of calorimeter condenser	°C
t_{w1}	temperature of water entering calorimeter	°C
t_{w2}	temperature of water leaving calorimeter	°C
v_n	velocity of air at nozzle	m/s
V_n	specific volume of dry air portion of mixture at nozzle	m ³ /kg
V'_n	specific volume of air at nozzle	m ³ /kg of air-water vapour mixture
W_{i1}	specific humidity of air entering indoor side	kg/kg of dry air
W_{i2}	specific humidity of air leaving indoor side	kg/kg of dry air
W_n	specific humidity at nozzle inlet	kg/kg of dry air
W_r	water vapour (rate) condensed by the equipment	g/s
X_r	mass ratio, refrigerant to refrigerant-oil mixture	—
Y	expansion factor	—

5 Airflow setting

5.1 General

This International Standard specifies airflow settings for ducted and non-ducted units and units supplied without a fan.

Ducted indoor units rated less than 8 kW and intended to operate at an external static pressure of less than 25 Pa shall be tested as non-ducted units.

5.2 Airflow setting for ducted indoor units

5.2.1 General

The airflow rate shall be specified by the manufacturer. This flow rate shall be for full-load cooling and be expressed in cubic metres per second (m³/s) of standard air conditions, as defined in 3.1, and correspond to a non-operating compressor.

5.2.2 Airflow setting procedure for ducted indoor units

The airflow rate setting shall be made when only the fan is operating, at an ambient temperature between 20 °C and 30 °C and a relative humidity between 30 % and 70 %. The airflow settings of the units shall be in accordance with Annex A.

The rated airflow rate given by the manufacturer shall be set and the resulting external static pressure, p_e , (ESP) measured. The measured ESP shall be larger than the ESP for rating, defined in Table 1. If the unit has an adjustable speed, it shall be adjusted to the lowest speed that provides at least the ESP for rating.

5.3 ESP for rating

5.3.1 If the rated ESP specified by the manufacturer is greater than or equal to the minimum value given in Table 1, the specified rated ESP is used as the ESP for rating.

5.3.2 If the rated ESP specified by the manufacturer is less than the minimum value given in Table 1, and larger than or equal to the 80 % of the maximum ESP, the specified rated ESP is used as the ESP for rating. The maximum ESP may either be specified by the manufacturer or identified from fan curves provided by the manufacturer.

5.3.3 If the rated ESP specified by the manufacturer is less than the minimum value given in Table 1 and less than 80 % of the maximum ESP, the value of Table 1 or 80 % of the maximum ESP, whichever is smaller, is used as the ESP for rating.

5.3.4 If the rated ESP is not specified by the manufacturer, the value of Table 1 or 80 % of the maximum ESP, whichever is smaller, is used as the ESP for rating.

5.3.5 The process of selecting the ESP for rating is shown in Figure 1.

If the determined ESP for rating is less than 25 Pa, the unit can be considered a non-ducted indoor unit.

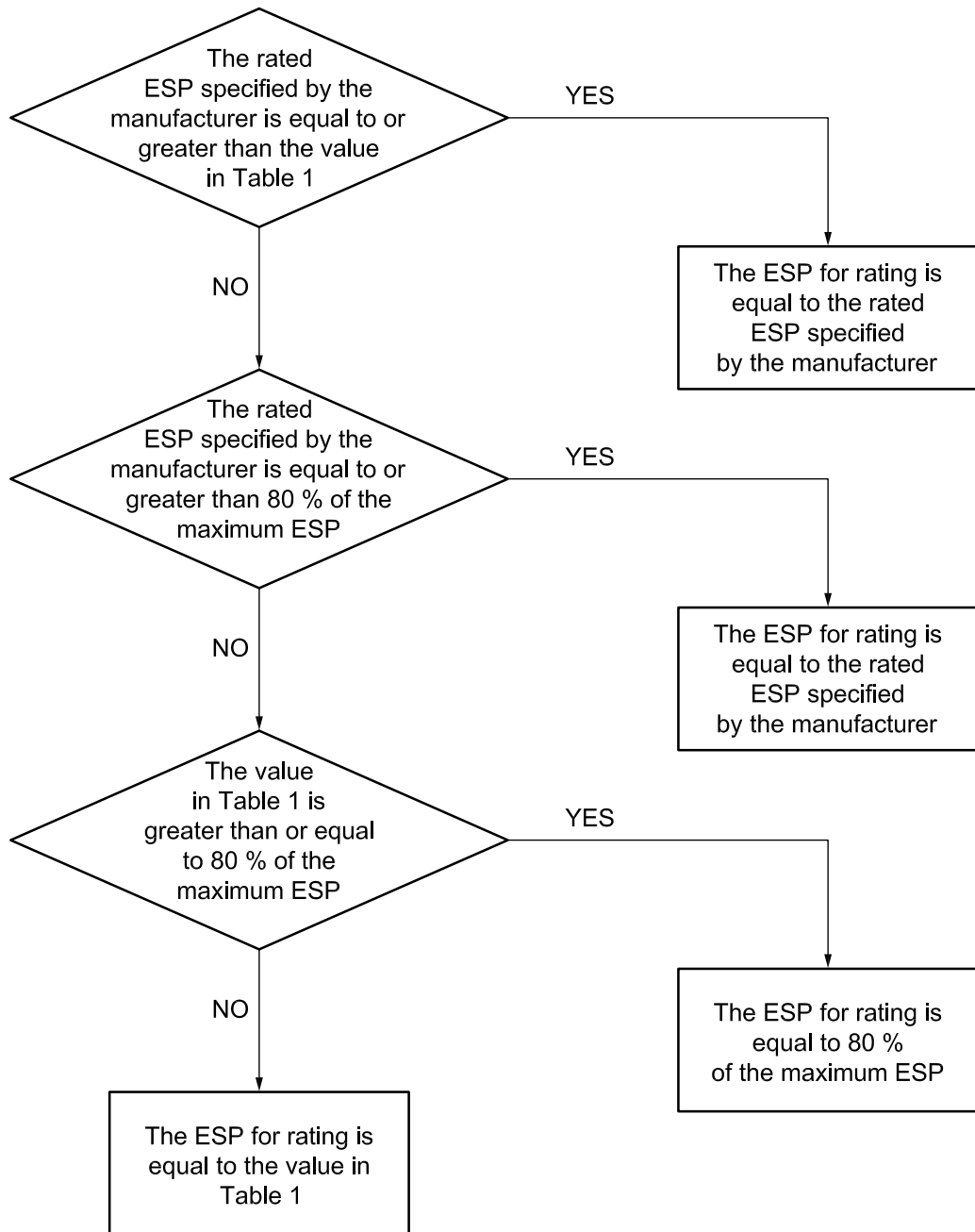

Figure 1 — Flowchart for selecting ESP for rating

Table 1 — Pressure requirement for comfort air-conditioners

Standard capacity ratings kW	Minimum external static pressure ^a Pa
$0 < Q < 8$	25
$8 \leq Q < 12$	37
$12 \leq Q < 20$	50
$20 \leq Q < 30$	62
$30 \leq Q < 45$	75
$45 \leq Q < 82$	100
$82 \leq Q < 117$	125
$117 \leq Q < 147$	150
$Q > 147$	175

^a For equipment tested without an air filter installed, the minimum ESP, p_e , shall be increased by 10 Pa.

5.4 Airflow setting for non-ducted indoor units measured by air-enthalpy method

5.4.1 Tests shall be conducted with 0 Pa static pressure maintained at the air discharge of the equipment. All air quantities shall be expressed as m³/s of standard air.

5.4.2 Airflow measurements shall be made in accordance with the provisions specified in Annex C, as appropriate, as well as the provisions established in other appropriate annexes of this International Standard.

NOTE Additional guidance for making airflow measurements can be found in ISO 3966 and ISO 5167-1.

5.5 Outdoor airflow

If the outdoor airflow is adjustable, all tests shall be conducted at the outdoor-side air quantity or fan control setting that is specified by the manufacturer. Where the fan is non-adjustable, all tests shall be conducted at the outdoor-side air volume flow rate inherent in the equipment when operated with the following in place: all of the resistance elements associated with inlets, louvers, and any ductwork and attachments considered by the manufacturer as normal installation practice. Once established, the outdoor-side air circuit of the equipment shall remain unchanged throughout all tests prescribed herein, except to adjust for any change caused by the attachment of the airflow measuring device when using the outdoor air-enthalpy test method (see K.2.1).

5.6 Unit supplied without indoor fan

If no fan is supplied with the unit (i.e. coil-only units), the requirements in Annex A and the supplemental requirements given in Annex P also apply.

6 Cooling tests

6.1 Cooling capacity test

6.1.1 General conditions

6.1.1.1 All equipment within the scope of this International Standard shall have the cooling capacities and energy efficiency ratios determined in accordance with the provisions of this International Standard and rated using the cooling conditions specified in Table 2. All tests shall be carried out in accordance with the test

requirements of Annex B and the test methods of Annex D and Annex E as specified in Clause 9. The electrical input values used for rating purposes shall be measured during the cooling capacity test.

6.1.1.2 The tests shall be conducted with all indoor units and compressors functioning during this test. Modular multi-split systems and modular heat recovery systems shall, for the purpose of this test, have the capacity ratio of indoor units to outdoor units equal to 1 ($\pm 5\%$).

6.1.1.3 Tests for modular and modular heat recovery systems may be conducted at part-load cooling capacities. If conducted, part-load cooling capacities shall be determined in accordance with the requirements of Annex F.

6.1.1.4 Tests may be conducted to determine the cooling capacities of individual indoor units, either operating with all other indoor units functioning or without any other indoor units functioning. If tests of the cooling capacities of individual indoor units are conducted, the capacities shall be determined in accordance with the requirements of Annex G.

6.1.1.5 The manufacturer shall specify, for variable-capacity compressors, the specific setting that is needed to give full-load capacity and the equipment shall be maintained at that setting. If the manufacturer does not define the setting, the thermostat or controller shall be set to its minimum allowable temperature setting.

6.1.1.6 If the equipment cannot be maintained at steady-state conditions by its normal controls, then the manufacturer shall modify or override such controls so that steady-state conditions are achieved.

6.1.2 Temperature conditions

6.1.2.1 The temperature conditions stated in Table 2 (columns T1, T2 and T3) shall be considered standard rating conditions for the determination of cooling capacity.

6.1.2.2 Equipment manufactured for use in a moderate climate similar to that specified in Table 2, column T1 only, shall have a rating determined by tests conducted at these specified T1 conditions and shall be designated type T1 equipment.

6.1.2.3 Equipment manufactured for use in a cool climate similar to that specified in Table 2, column T2 only, shall have a rating determined by tests conducted at these specified T2 conditions and shall be designated type T2 equipment.

6.1.2.4 Equipment manufactured for use in a hot climate similar to that specified in Table 2, column T3 only, shall have a rating determined by tests conducted at these specified T3 conditions and shall be designated type T3 equipment.

6.1.2.5 Equipment manufactured for use in more than one of the types of climate defined in Table 2 (columns T1, T2 and T3) shall have its rating determined by tests for each of the specified Table 1 conditions for which they have been designated and tested.

Table 2 — Cooling capacity rating conditions

Parameter	Standard rating conditions		
	T1	T2	T3
Temperature of air entering indoor-side:			
— dry-bulb	27 °C	21 °C	29 °C
— wet-bulb	19 °C	15 °C	19 °C
Temperature of air entering outdoor-side:			
— dry-bulb	35 °C	27 °C	46 °C
— wet-bulb ^a	24 °C	19 °C	24 °C
Test frequency ^b	Rated frequency		
Test voltage	See Table 3		
NOTE			
T1 = Standard cooling capacity rating conditions for moderate climates.			
T2 = Standard cooling capacity rating conditions for cool climates.			
T3 = Standard cooling capacity rating conditions for hot climates.			
^a The wet-bulb temperature condition shall only be required when testing air-cooled condensers that evaporate the condensate.			
^b Equipment with dual-rated frequencies shall be tested at each frequency.			

Table 3 — Voltages for capacity and performance tests (except maximum cooling and maximum heating performance tests)

Rated (nameplate) voltages ^a	Test voltage ^b
V	V
90 to 109	100
110 to 127	115
180 to 207	200
208 to 253	230
254 to 341	265
342 to 420	400
421 to 506	460
507 to 633	575
^a For equipment with dual-rated voltages such as 115/230 and 220/440, the test voltages would be 115 V and 230 V in the first example, and 230 V and 460 V in the second example. For equipment with an extended voltage range, such as 110 V to 120 V or 220 V to 240 V, the test voltage would be 115 V or 230 V, respectively. Where the extended voltage range spans two or more of the rated voltage ranges, the mean of the rated voltages shall be used to determine the test voltage from the table. EXAMPLE For equipment with an extended voltage range of 200 V to 220 V, the test voltage would be 230 V, based on the mean voltage of 210 V.	
^b The voltages in this table are for capacity and performance tests other than the maximum cooling and maximum heating performance tests.	

6.1.3 Test conditions

6.1.3.1 Preconditions

The test room reconditioning apparatus and the equipment under test shall be operated until equilibrium conditions are attained. Equilibrium conditions as required by 9.3 shall be maintained for not less than 1 h before capacity test data are recorded.

6.1.3.2 Testing requirements

The test capacity shall include the determination of the sensible, latent and total cooling capacity as determined on the indoor-side.

6.1.3.3 Duration of test

The data shall be recorded at equal intervals that span 1 min or less. The recording of the data shall continue for at least a 30 min period during which the tolerances specified in 9.3 shall be met.

6.2 Maximum cooling performance test

6.2.1 General conditions

The conditions which shall be used during the maximum cooling test are given in Table 4. The test shall be conducted with the equipment functioning at full capacity, as defined in 3.2. The test voltages in Table 3 shall be maintained at the specified percentages under running conditions. In addition, the test voltage shall be adjusted so that it is not less than 86 % of the rated voltage at the moment of restarting the equipment after the shut-down required in 6.2.4.2. The determination of cooling capacity and electrical power input is not required for this performance test.

6.2.2 Temperature conditions

Tests shall be carried out according to the conditions in Column T1, T2, or T3 of Table 4 based on intended use, as determined in 6.1.2. For equipment rated for use under more than one set of operating conditions, the highest relevant set of the intended operating conditions shall be applied for test purposes.

6.2.3 Airflow conditions

The maximum cooling test shall be conducted with an indoor-side fan speed setting as determined in 5.2.

6.2.4 Test conditions

6.2.4.1 Preconditions

The controls of the equipment shall be set for maximum cooling.

6.2.4.2 Duration of test

The equipment shall be operated continuously for 1 h after the specified air temperatures have been established (see Tables 4 and 14). All power to the equipment shall then be cut off for 3 min and then restored. The equipment may be restarted either automatically or through the use of a remote controller or similar device. The test shall continue for 60 min after the equipment restarts.

6.2.5 Performance requirements

6.2.5.1 Air-conditioners and heat pumps shall meet the following requirements when operating at the conditions specified in Table 4:

- a) during one entire test, the equipment shall operate without any indication of damage;
- b) the motors of the equipment shall operate continuously for the first hour of the test without the tripping of any protective device, and
- c) after the interruption of power, the equipment shall resume operation within 30 min and run continuously for 1 h, except as specified in 6.2.5.2 and 6.2.5.3

6.2.5.2 The protective devices may trip only during the first 5 min of operation after the shut-down period of 3 min. During the remainder of that 1 h test period, no motor overload protective device shall trip. The equipment shall be permitted to start and stop under the control of an automatic limit device, if provided.

6.2.5.3 For those models designed so that resumption of operation does not occur after an initial trip within the first 5 min, the equipment may remain out of operation for not longer than 30 min. It shall then operate continuously for 1 h.

Table 4 — Maximum cooling test conditions

Parameter	Standard rating conditions		
	T1	T2	T3
Temperature of air entering indoor-side:			
— dry-bulb	32 °C	27 °C	32 °C
— wet-bulb	23 °C	19 °C	23 °C
Temperature of air entering outdoor-side:			
— dry-bulb	43 °C	35 °C	52 °C
— wet-bulb ^a	26 °C	24 °C	31 °C
Test frequency ^b	Rated frequency		
Test voltage	a) 90 % and 110 % of rated voltage with a single nameplate voltage rating. b) 90 % of the lower rated voltage and 110 % of the higher rated voltage for units with a dual or extended nameplate voltage rating.		
^a	The wet-bulb temperature condition shall only be required when testing air-cooled condensers that evaporate the condensate.		
^b	Equipment with dual-rated frequencies shall be tested at each frequency.		

6.3 Minimum cooling test

6.3.1 General conditions

The test conditions specified in Table 5 shall be used when conducting the minimum cooling and freeze-up air blockage test. All indoor units shall be functioning during this test.

6.3.2 Temperature conditions

Tests shall be conducted at the temperature conditions specified in Table 5. If lower minimum operating temperature conditions are specified in the manufacturer's specification sheets, they shall be used in lieu of those given in Table 5.

6.3.3 Airflow conditions

The controls, fan speeds, dampers and grilles of the equipment shall be set to produce the maximum tendency to frost or ice the evaporator, providing such settings are not contrary to the manufacturer's operating instructions.

6.3.4 Test condition

6.3.4.1 Preconditions

The equipment shall be started and operated until operating conditions have stabilized.

6.3.4.2 Duration of test

After the operating conditions have stabilized (Table 5 and Table 14), the equipment shall be operated for a period of 4 h. The equipment shall be permitted to stop and start under the control of an automatic limit device, if provided.

6.3.5 Performance requirements

6.3.5.1 The equipment shall operate under the conditions specified without any indication of damage.

6.3.5.2 At the end of the 4 h test, any accumulation of frost or ice on the indoor coil shall not cover more than 50 % of the indoor-side face area of the indoor coil or reduce the airflow rate by more than 25 % of the initial airflow rate. If the equipment and test apparatus do not allow visual observation of the indoor coil or if the indoor air volume rate is not measured, then the requirements of 6.3.5.3 shall be met.

6.3.5.3 During the 4 h test period, the midpoint temperature of every indoor coil circuit or the refrigerant suction pressure shall be measured at equal intervals that span 1 min or less. The measurement(s) made 10 min after beginning the 4 h test shall be defined as the initial value(s). If the suction pressure is measured, it shall be used to calculate the saturated suction temperature.

- a) If the compressor(s) does(do) not cycle off on automatic controls during the test and
- if coil circuit temperatures are measured, the temperatures shall not remain more than 2 °C below the corresponding initial value for each circuit for more than 20 consecutive min, or
 - if suction pressure is measured, the saturated suction temperature shall not remain more than 2 °C below the initial value for more than 20 consecutive min.
- b) If the compressor(s) cycle(s) on and off on the automatic controls during the test and
- if coil circuit temperatures are measured, the individual circuit temperatures measured 10 min after the beginning of any on cycle during the test shall not be more than 2 °C below the corresponding initial circuit temperature(s), or
 - if suction pressure is measured, the saturated suction temperature measured 10 min after the beginning of any "on" cycle during the test shall not be more than 2 °C below the initial saturated suction temperature.

6.4 Freeze-up drip test (applies to non-ducted multi-splits)

6.4.1 General conditions

The freeze-up drip test shall be run immediately after completion of the minimum cooling and freeze-up air blockage test and at the conditions specified in Table 5. The test shall be conducted with the equipment functioning at full-load operation, as defined in 3.20, except as required in 5.4. The determination of capacity and electrical power is not required for this performance test.

6.4.2 Temperature conditions

The temperature conditions for the freeze-up drip test are given in Table 5.

6.4.3 Airflow conditions

The air inlet to the indoor coil shall be covered to completely block the passage of air, so as to attempt to achieve complete blockage of the evaporator by frost or ice.

6.4.4 Test conditions

6.4.4.1 Preconditions

The equipment shall be started and operated until the operating conditions have stabilized.

6.4.4.2 Duration of test

After the operating conditions have stabilized, the equipment shall be operated for a period of 4 h. The equipment shall be permitted to stop and start under the control of an automatic limit device, if provided. At the end of the 4 h test, the equipment shall be stopped and the air inlet covering removed until the accumulation of frost or ice has melted. The equipment shall then be turned on with the fan(s) operating at the highest speed for 5 min.

6.4.5 Performance requirements

During the test, no ice shall drip from the coil and no water shall drip or blow off the equipment on the indoor side.

Table 5 — Minimum cooling — Freeze-up air blockage and freeze-up drip test conditions

Parameter	Standard test conditions	
	T1 and T3	T2
Temperature of air entering indoor-side:		
— dry-bulb	21 °C	21 °C
— wet-bulb	15 °C	15 °C
Temperature of air entering outdoor-side:		
— dry-bulb	21 °C	10 °C
— wet-bulb ^a	—	—
Test frequency ^b	Rated frequency	
Test voltage	See Table 3	
^a The wet-bulb temperature condition shall only be required when testing air-cooled condensers that evaporate the condensate.		
^b Equipment with dual-rated frequencies shall be tested at each frequency.		

6.5 Condensate control test and enclosure sweat test

6.5.1 General conditions

The conditions which shall be used during the condensate control and enclosure sweat test are given in Table 5. All indoor units shall be functioning during this test. This test is not required for ducted units.

6.5.2 Temperature conditions

The temperature conditions which shall be used during this test are given in Table 6.

6.5.3 Airflow conditions

The controls, fans, dampers and grilles of the equipment shall be set to produce the maximum tendency to sweat, provided such settings are not contrary to the manufacturer's operating instructions.

6.5.4 Test conditions

6.5.4.1 Preconditions

After establishing the specified temperatures, equipment without condensate pumps shall be started with the condensate collection pan filled to the overflowing point and shall be run until the condensate flow has become uniform (see Tables 6 and 14).

6.5.4.2 Duration of test

The equipment shall be operated for a period of 4 h.

6.5.5 Performance requirements

6.5.5.1 When operating at the test conditions specified in Table 6, no condensed water shall drip, run or blow from the equipment nor shall the equipment shut down.

6.5.5.2 Equipment that rejects condensate to the condenser air shall dispose of all condensate and there shall be no dripping or blowing-off of water from the equipment such that the building or surroundings become wet.

Table 6 — Condensate control test conditions

Parameter	Standard test conditions
Temperature of air entering indoor-side:	
— dry-bulb	27 °C
— wet-bulb	24 °C
Temperature of air entering outdoor-side:	
— dry-bulb	27 °C
— wet-bulb ^a	24 °C
Test frequency ^b	Rated frequency
Test voltage ^c	See Table 3
^a The wet-bulb temperature condition shall only be required when testing air-cooled condensers that evaporate the condensate. ^b Equipment with dual-rated frequencies shall be tested at each frequency. ^c Equipment with dual-rated voltages shall be tested at the higher voltage.	

7 Heating tests

7.1 Heating capacity tests

7.1.1 General conditions

7.1.1.1 For all heating capacity tests, the requirements specified in Annex B shall apply. Testing shall be conducted using the method(s) and instrumentation that meet the requirements of 9.1 and 9.2. To constitute a valid test, the test tolerances specified in 9.3 shall be satisfied.

7.1.1.2 All Clause 7 heating capacity tests shall be conducted at the standard rating conditions specified in Table 7 with the heat pump operating at full capacity, as defined in 3.2, with all indoor units and compressors functioning. Modular multi-split systems and modular heat recovery systems shall, for the purposes of this test, have a capacity ratio of indoor units to outdoor units equal to 1 ($\pm 5\%$).

7.1.1.3 The electrical input values used for rating purposes shall be measured during the heating capacity tests. Resistive elements used for heating indoor air other than those used for defrosting shall be prevented from operating during the heating capacity tests.

7.1.1.4 Tests of modular systems and modular heat recovery systems may be conducted at part-load heating capacities. If conducted, part-load heating capacities shall be determined in accordance with the requirements of Annex F.

7.1.1.5 Tests may be conducted to determine the heating capacities of individual indoor units, either operating with all other indoor units functioning or without any other indoor units functioning. If tests are conducted, the capacities shall be determined in accordance with the requirements of Annex G.

7.1.1.6 If the manufacturer does not specify otherwise, the thermostat or controller shall be set at its maximum allowable temperature setting.

7.1.2 Temperature conditions

7.1.2.1 Three different outdoor-side temperature conditions, designated as H1, H2 and H3, are specified in Table 7.

7.1.2.2 Table 7 temperature conditions for the air entering the indoor side of the equipment shall be used for all heating capacity tests.

7.1.2.3 All heat pumps shall be rated based on testing at the H1 temperature conditions. Heating capacity tests shall also be conducted at the H2 and/or H3 temperature conditions if the manufacturer rates the equipment for operation at one or both of these temperature conditions.

7.1.2.4 If the heat pump is rated for operation at two frequencies or, in some cases, if the equipment has a dual-rated voltage, then more than one heating capacity test shall be conducted at each applicable outdoor-side temperature condition. Table 6 (and Table 2) shall be used to determine if additional heating capacity tests are required.

Table 7 — Heating capacity rating conditions

Parameter	Standard rating conditions		
	H1 ^a	H2 ^a	H3 ^a
Temperature of air entering indoor-side:			
— dry-bulb	20 °C		
— wet-bulb (maximum)	15 °C		
Temperature of air entering outdoor-side:			
— dry-bulb	7 °C	2 °C	-7 °C
— wet-bulb	6 °C	1 °C	-8 °C
Test frequency ^b	Rated frequency		
Test voltage	See Table 3		
^a If a defrosting cycle occurs during the H1, H2 or H3 heating capacity tests, testing under these conditions shall be accomplished using either the calorimeter or the indoor air enthalpy method (see Annexes C and D).			
^b Equipment with dual-rated frequencies shall be tested at each frequency.			

7.1.3 Airflow conditions

7.1.3.1 For ducted indoor units, measurement of the indoor-side air volume rate is required in all cases, regardless of whether the calorimeter test method or the indoor air enthalpy test method is used to provide the primary measurement of heating capacity.

7.1.3.2 Airflow measurements shall be made in accordance with the provisions specified in Annex A for ducted units and Annex C for other units, as appropriate, as well as the provisions established in the other annexes of this International Standard.

NOTE Additional guidance concerning airflow measurement can be found in ISO 3966 and ISO 5167-1.

NOTE All airflow rates are expressed in units of cubic metres per second of standard air. For the heating capacity calculations described in Annex E, the indoor-side airflow rate is expressed in units of cubic metres per second of the air-water vapour mixture.

7.1.3.3 When tests are made at settings other than those prescribed in 7.1.3.4 and 7.1.3.5, these alternative settings shall be noted together with the heating capacity ratings.

7.1.3.4 Equipment settings, both on the indoor and outdoor air sides, shall be the same as those established during the cooling capacity tests. The heating capacity tests shall be conducted at the outdoor-side airflow rate that is inherent in the outdoor-side air circuit, with the exception of any adjustments allowed if using the outdoor air-enthalpy test method (see Annex K).

7.1.3.5 For ducted indoor units, heating capacity tests shall be conducted with the same setting of the damper or exhaust fan as for the cooling capacity test. If cooling capacity tests are conducted for more than one climatic condition (T1, T2, T3) with different flow rates, then the setting giving the highest flow rate shall be used to conduct the heating capacity tests.

7.1.4 Defrost operation

7.1.4.1 Overriding of automatic defrost controls shall be prohibited. The controls may only be overridden when manually initiating a defrost cycle during preconditioning.

7.1.4.2 Any defrost cycle, whether automatically or manually initiated, that occurs while preparing for or conducting a heating capacity test, shall always be automatically terminated by the action of the heat pump's defrost controls.

7.1.4.3 If the heat pump turns the indoor fan off during the defrost cycle, airflow through the indoor coil shall cease.

7.1.5 Test procedure — General

7.1.5.1 The test procedure consists of three periods: a preconditioning period, an equilibrium period and a data collection period. The duration of the data collection period differs depending on whether the heat pump's operation is steady-state or transient. In addition, in the case of transient operation, the data collection period specified when using the indoor air enthalpy method (see 7.1.11.5) is different from the data collection period required if using the calorimeter method (see 7.1.11.6).

7.1.5.2 Annex Q pictorially represents most of the different test sequences which are possible when conducting a heating capacity test.

7.1.6 Preconditioning period

7.1.6.1 The test room reconditioning apparatus and the heat pump under test shall be operated until the test tolerances specified in 9.3 are attained for at least 10 min.

7.1.6.2 A defrost cycle may end a preconditioning period. If a defrost cycle does end a preconditioning period, the heat pump shall operate in the heating mode for at least 10 min after defrost termination prior to beginning the equilibrium period.

7.1.6.3 It is recommended that the preconditioning period end with an automatic or manually induced defrost cycle when testing at the H2 and H3 temperature conditions.

7.1.7 Equilibrium period

7.1.7.1 The equilibrium period immediately follows the preconditioning period.

7.1.7.2 A complete equilibrium period is 1 h in duration.

7.1.7.3 Except as specified in 7.1.11.3, the heat pump shall operate while meeting the 9.3 test tolerances.

7.1.8 Data collection period

7.1.8.1 The data collection period immediately follows the equilibrium period.

7.1.8.2 Data shall be collected as specified for the test method(s) chosen from 9.1. If using the calorimeter method, heating capacity shall be calculated as specified in Annex D. If using the indoor air enthalpy method, heating capacity shall be calculated as specified in Annex E. For cases where one of the confirmative test methods of 9.1.3.1 is used, heating capacity shall be calculated as specified in the appropriate annex.

7.1.8.3 An integrating electrical power (watt-hour) meter or measuring system shall be used for measuring the electrical energy supplied to the equipment. During defrost cycles and for the first 10 min following a defrost termination, the meter or measuring system shall have a sampling rate of at least every 10 s.

7.1.8.4 Except as specified in 7.1.8.3 and 7.1.8.5, data shall be sampled at equal intervals that span 30 s or less.

7.1.8.5 During defrost cycles, plus the first 10 min following defrost termination, certain data used in evaluating the integrated heating capacity of the heat pump shall be sampled at equal intervals that span 10 s or less. When using the indoor air enthalpy method, these more frequently sampled data include the change in indoor-side dry-bulb temperature. When using the calorimeter method, these more frequently sampled data include all measurements required to determine the indoor-side capacity.

7.1.8.6 For heat pumps that automatically cycle off the indoor fan during a defrost, the contribution of the net heating delivered and/or the change in indoor-side dry-bulb temperature shall be assigned the value of zero when the indoor fan is off, if using the indoor air enthalpy method. If using the calorimeter test method, the integration of capacity shall continue while the indoor fan is off.

7.1.8.7 For both the indoor air-enthalpy and calorimeter test methods, the difference between the dry-bulb temperature of the air leaving and entering the indoor coil shall be measured. For each 5 min interval during the data collection period, an average temperature difference shall be calculated, $\Delta t_i(\tau)$. The average temperature difference for the first 5 min of the data collection period, $\Delta t_i(\tau = 0)$, shall be saved for the purpose of calculating the change, Δt , expressed as a percentage, as given in Equation (1):

$$\% \Delta t = \left[\frac{\Delta t_i(\tau = 0) - \Delta t_i(\tau)}{\Delta t_i(\tau = 0)} \right] \times 100 \% \quad (1)$$

7.1.9 Test procedure when a defrost cycle (whether automatically or manually initiated) ends the preconditioning period (7.1.6)

7.1.9.1 If the quantity $\% \Delta t$ exceeds 2,5 % during the first 35 min of the data collection period, the heating capacity test shall be designated as a transient test (see 7.1.11). Likewise, if the heat pump initiates a defrost cycle during the equilibrium period or during the first 35 min of the data collection period, the heating capacity test shall be designated as a transient test.

7.1.9.2 If the conditions specified in 7.1.9.1 do not occur and the test tolerances given in 9.3 are satisfied during both the equilibrium period and the first 35 min of the data collection period, then the heat capacity test shall be designated a steady-state test. Steady-state tests shall be terminated after 35 min of data collection.

7.1.10 Test procedure when a defrost cycle does not end the preconditioning period (7.1.6)

7.1.10.1 If the heat pump initiates a defrost cycle during the equilibrium period or during the first 35 min of the data collection period, the heating capacity test shall be restarted as specified in 7.1.10.3.

7.1.10.2 If the quantity $\% \Delta t$ exceeds 2,5 % any time during the first 35 min of the data collection period, the heating capacity test shall be restarted as specified in 7.1.10.3. Prior to the restart, a defrost cycle shall occur. This defrost cycle may be manually initiated or delayed until the heat pump initiates an automatic defrost.

7.1.10.3 If either 7.1.10.1 or 7.1.10.2 apply, then the restart shall begin 10 min after the defrost cycle terminates with a new, 1-h-long equilibrium period. This second attempt shall follow the requirements of 7.1.7 and 7.1.8, and the test procedure of 7.1.9.

7.1.10.4 If the conditions specified in 7.1.10.1 or 7.1.10.2 do not occur and the test tolerances given in 9.3 are satisfied during both the equilibrium period and the first 35 min of the data collection period, then the heat capacity test shall be designated as a steady-state test. Steady-state tests shall be terminated after 35 min of data collection.

7.1.11 Test procedure for transient tests

7.1.11.1 When, in accordance with 7.1.9.1, a heating capacity test is designated as a transient test, the adjustments specified in 7.1.11.2 to 7.1.11.5 shall apply.

7.1.11.2 The outdoor air-enthalpy test method shall not be used and its associated outdoor-side measurement apparatus shall be disconnected from the heat pump. In all cases, the normal outdoor-side airflow of the heat pump shall not be disturbed. The use of other confirming test methods is not required.

7.1.11.3 To constitute a valid transient heating capacity test, the test tolerances specified in Table 8 shall be achieved during both the equilibrium period and the data collection period. As noted in Table 8, the test tolerances are specified for two subintervals. Interval H consists of data collected during each heating interval,

with the exception of the first 10 min after defrost termination. Interval D consists of data collected during each defrost cycle plus the first 10 min of the subsequent heating interval.

7.1.11.4 The test tolerance parameters in Table 8 shall be sampled throughout the equilibrium and data collection periods. All data collected during each interval, H or D, shall be used to evaluate compliance with the Table 7 test tolerances. Data from two or more H intervals or two or more D intervals shall not be combined and then used in evaluating Table 6 compliance. Compliance is based on evaluating data from each interval separately.

7.1.11.5 If using the indoor air enthalpy method, the data collection period shall be extended until 3 h have elapsed or until the heat pump completes three complete cycles during the period, whichever occurs first. If, at an elapsed time of 3 h, the heat pump is conducting a defrost cycle, the cycle shall be completed before terminating the collection of data. A complete cycle consists of a heating period and a defrost period, from defrost termination to defrost termination.

7.1.11.6 If using the calorimeter method, the data collection period shall be extended until 6 h have elapsed or until the heat pump completes six complete cycles during the period, whichever occurs first. If, at an elapsed time of 6 h, the heat pump is conducting a defrost cycle, the cycle shall be completed before terminating the collection of data. A complete cycle consists of a heating period and a defrost period, from defrost termination to defrost termination.

NOTE Consecutive cycles are repetitive with similar frost and defrost intervals before selecting data used for calculating the integrated capacity and power.

7.1.11.7 Because of the confirming test method requirement of 9.1.3.1, the outdoor air enthalpy test apparatus may have to be disconnected from the heat pump, as specified in 7.1.11.2, during a heating capacity test. If removal during a test is required, the changeover interval shall not be counted as part of the elapsed time of the equilibrium or data collection periods. The changeover interval shall be defined as starting the instant the heating capacity test is designated a transient test and ending when the test tolerances from Table 8 are first re-established after the outdoor air-enthalpy apparatus is disconnected from the heat pump.

Table 8 — Variations allowed in heating capacity tests when using the transient (T) test procedure

Reading	Variation of arithmetical mean values from specified test conditions		Variation of individual readings from specified test conditions	
	Interval H ^a	Interval D ^b	Interval H ^a	Interval D ^b
Temperature of air entering indoor-side:				
— dry-bulb	±0,6 °C	±1,5 °C	±1,0 °C	±2,5 °C
— wet-bulb	—	—	—	—
Temperature of air entering outdoor-side:				
— dry-bulb	±0,6 °C	±1,5 °C	±1,0 °C	±5,0 °C
— wet-bulb	±0,3 °C	±1,0 °C	±0,6 °C	—
Voltage	—	—	±2 %	±2 %
External resistance to airflow	—	—	±5 Pa	—
^a Applies when the heat pump is in the heating mode, except for the first 10 min after termination of a defrost cycle. ^b Applies during a defrost cycle and during the first 10 min after the termination of a defrost cycle when the heat pump is operating in the heating mode.				

7.1.12 Heating capacity test results

7.1.12.1 The electrical energy supplied to the heat pump during the applicable test period specified in 7.1.8 shall be measured along with the corresponding elapsed time, in hours, of the test period.

7.1.12.2 Average heating capacity and average electrical power input shall be calculated in accordance with 10.1.4 and 10.1.5 using data from the total number of complete cycles that are achieved before data collection is terminated. In the event that the equipment does not undergo a defrost cycle during the data collection period, the entire 6 h data set shall be used for the calculations.

7.2 Maximum heating performance test

7.2.1 General conditions

The conditions given in Table 9 shall be used during the maximum heating performance test. The determination of heating capacity is not required for this performance test. The test voltages in Table 9 shall be maintained at the specified percentages under running conditions. All indoor units and compressors shall be functioning during this test.

7.2.2 Temperature conditions

The temperature conditions given in Table 9 shall be used during these tests, unless the manufacturer specifies higher temperature conditions in the manufacturer's equipment specification sheets.

7.2.3 Airflow conditions

The maximum heating test shall be conducted using the indoor-side fan speed setting determined in 5.2.

7.2.4 Test conditions

7.2.4.1 Preconditions

The controls of the equipment shall be set for maximum heating.

7.2.4.2 Duration of test

The equipment shall be operated for 1 h after the specified air temperatures have been attained. The equipment shall be permitted to stop and start under the control of an automatic limit device, if provided.

Table 9 — Maximum heating test conditions

Parameter	Standard test conditions
Temperature of air entering indoor-side: — dry-bulb	27 °C
Temperature of air entering outdoor-side: — dry-bulb — wet-bulb	24 °C 18 °C
Test frequency ^a	Rated frequency
Test voltage	a) 90 % and 110 % of rated voltage for equipment with a single nameplate voltage rating b) 90 % of the lower rated voltage and 110 % of the higher rated voltage for equipment with a dual or extended nameplate voltage rating
^a Equipment with dual-rated frequencies shall be tested at each frequency.	

7.2.4.3 The equipment shall operate under the conditions specified in Table 9 and 7.2.4.2, without indication of damage.

7.2.4.4 The motor overload protective devices may trip only during the first 5 min following the 3 min cut-off of power. During the remainder of that 1 h test period, no motor overload protective device shall trip.

7.2.4.5 For equipment designed so that resumption of operation does not occur after initial trip within the first 5 min, the equipment may remain out of operation for not longer than 3 min. It shall then operate continuously for 1 h.

7.3 Minimum heating performance test

7.3.1 General conditions

The conditions given in Table 10 shall be used for this test. The test shall be conducted with the equipment functioning at full-load operation, as defined in 3.20. The voltage shall be maintained at the specified value under running conditions. All indoor units and compressors shall be functioning during this test. The determination of the heating capacity and electrical power input is not required for this performance test.

7.3.2 Temperature conditions

The temperature conditions shall be as given in Table 10, unless the manufacturer specifies lower conditions in the manufacturer's equipment specification sheets.

7.3.3 Airflow conditions

The controls of the equipment shall be set for maximum heating. All ventilating air dampers and exhaust air dampers, if provided, shall be closed.

Table 10 — Minimum heating test conditions

Parameter	Standard test conditions
Temperature of air entering indoor-side: — dry-bulb	20 °C
Temperature of air entering outdoor-side ^a : — dry-bulb — wet-bulb	-7 °C -8 °C
Test frequency ^b	Rated frequency
Test voltage ^c	See Table 3

^a If the equipment can be operated under the H3 temperature condition, -7 °C dry-bulb and -8 °C wet-bulb shall be used in lieu of -5 °C/-6 °C.

^b Equipment with dual-rated frequencies shall be tested at each frequency.

^c Equipment with dual-rated voltage shall be tested at the higher voltage. This requirement for testing at a single voltage shall supersede.

7.3.4 Test conditions

7.3.4.1 Preconditions

The equipment shall be operated for a sufficient period of time to reach stable operating conditions as specified in Table 10.

7.3.4.2 Duration of test

After the equipment has reached stable operating conditions (Tables 10 and 13), these conditions shall be maintained for 1 h.

7.3.5 Performance requirements

The equipment shall operate throughout the test without activation of any manual reset device. The equipment shall be permitted to stop and start under the control of an automatic limit device, if provided.

The equipment shall operate under the conditions specified in Table 10 and 7.3.4.2, without indication of damage.

7.4 Automatic defrost test

7.4.1 General conditions

This test is not required if provision is made to ensure that cool air (less than 18 °C) is not blown into the conditioned space during defrost. The test shall be conducted with the equipment functioning at full capacity, as defined in 3.2, except as required in 7.4.3. The conditions for test frequency and test voltage given in Table 6 shall be used during the automatic defrost test. The determination of heating capacity and electrical power input is not required for this performance test.

7.4.2 Temperature conditions

The temperature conditions specified for H2 conditions in Table 7 shall be used during the automatic defrost test.

7.4.3 Airflow conditions

Unless prohibited by the manufacturer, the indoor-side fan is to be adjusted to the highest speed and the unit outdoor-side fan to the lowest speed, if separately adjustable.

7.4.4 Test conditions

7.4.4.1 Preconditions

The equipment shall be operated until the temperatures specified for H2 conditions in Table 7 have been stabilized.

7.4.4.2 Duration of test

The heat pump shall remain in operation for two complete defrosting periods or for 3 h, whichever is longer.

7.4.5 Performance requirements

During the defrosting period, the temperature of the air from the indoor-side of the equipment shall not be lower than 18 °C for longer than 1 min.

8 Heat recovery test

8.1 Heat recovery capacity ratings

8.1.1 General conditions

8.1.1.1 All modular heat recovery systems shall have heat recovery capacities and heat recovery efficiencies (HRE) determined in accordance with the provisions of this International Standard. All tests shall be carried out in accordance with the test requirements of Annex B and the test methods described in Annex D, Annex E and Annex H.

8.1.1.2 All indoor units shall be functioning during this test, with the system operating at the capacity ratio of 1, or as close thereto as possible.

8.1.1.3 The manufacturer shall specify the inverter frequency of the compressor needed to give full-load conditions, as defined in 3.20, and the equipment shall be maintained at that frequency. If the equipment cannot be maintained at steady-state conditions by its normal controls, then the manufacturer shall specify how to modify or over-ride such controls so that steady-state conditions can be achieved.

8.1.2 Temperature conditions

The temperature conditions shall be as specified in Table 11.

Table 11 — Heat recovery test conditions

	3-room calorimeter or air enthalpy		2-room air enthalpy	
	d.b. temperature	w.b. temperature	d.b. temperature	w.b. temperature
Outdoor-side	7 °C	6 °C	7 °C	6 °C
Indoor-side:				
— heating	20 °C	15 °C (max)	20 °C	19 °C
— cooling	27 °C	19 °C	20 °C	19 °C
Test frequency ^a				Rated frequency
Test voltage ^b				See Table 3
^a Equipment with dual-rated frequencies shall be tested at each frequency.				
^b The test voltage of dual-rated equipment shall be tested at the higher voltage of Table 2.				

9 Test methods and uncertainties of measurement

9.1 Test methods

9.1.1 General

Capacity tests shall be conducted in accordance with the testing requirements specified in Annex B using either the calorimeter test method (see Annex D) or the indoor air-enthalpy test method (see Annex E), subject to the provision that the test results are within the limits of uncertainties of measurements established in 9.2.

9.1.2 Calorimeter test method

9.1.2.1 When using the calorimeter test method, two simultaneous methods for determining capacities shall be used. One method determines the capacity on the indoor side, the other measures the capacity on the outdoor side. In order to be valid, the capacity determined using the outdoor-side data shall agree within 5 % of the value obtained using the indoor-side data for the test.

9.1.2.2 For steady-state tests, the measurements shall be considered valid only if the measured capacity at each 10 min time interval does not vary by more than 2 % from the average measured capacity of the entire test period.

9.1.2.3 The apparatus used to make the indoor-side airflow and static pressure measurements shall be located within the indoor-side compartment of the calorimeter for all tests, except where specifications in A.3 are used for setting the airflow. In this case, the airflow measuring apparatus may be removed after the damper has been set to obtain the required airflow and static pressure.

9.1.3 Indoor air enthalpy method

9.1.3.1 A confirming test may be conducted to verify the results obtained using the indoor air-enthalpy test method. The following test methods may be used for confirming purposes:

- a) outdoor water coil method (see Annex I);
- b) compressor calibration method (see Annex I);
- c) refrigerant enthalpy method (see Annex J);
- d) outdoor air-enthalpy test method (see Annex K);
- e) indoor calorimeter confirmative test method (see Annex L);
- f) outdoor calorimeter confirmative test method (see Annex M);
- g) balanced-type calorimeter confirmative test method (see Annex N).

NOTE Annex N is not used as a confirmative test by testing laboratories (see N.1.1).

9.1.3.2 The results of the primary test shall agree with the results of the confirmative test within 6 % to be valid.

9.2 Uncertainty of measurement

9.2.1 The uncertainty of measurement shall not exceed the values specified in Table 12.

9.2.2 The steady-state cooling and heating capacities determined using the calorimeter method shall be determined with a maximum uncertainty of 5 %. This value is an expanded uncertainty of measurement expressed at the level of confidence of 95 %.

9.2.3 Heating capacity determined during transient operation (defrost cycles) using the calorimeter method shall be determined with a maximum uncertainty of 10 %. This value is an expanded uncertainty of measurement expressed at the level of confidence of 95 %.

9.2.4 The heating and cooling capacities measured on the air side using the air enthalpy method shall be determined with a maximum uncertainty of 10 %. This value is an expanded uncertainty of measurement expressed at the level of confidence of 95 %.

Table 12 — Uncertainties of measurement

Measured quantity	Uncertainty of measurement ^a
Air:	
— dry-bulb temperature	0,2 °C
— wet-bulb temperature ^b	0,3 °C
— volume flow	5 %
— static pressure difference	5 Pa for pressure ≤100 Pa 5 % for pressure >100 Pa
Electrical inputs	0,5 %
Time	0,2 %
Mass	1,0 %
Speed	1,0 %
<p>NOTE Uncertainty of measurement comprises, in general, many components. Some of these components may be estimated on the basis of the statistical distribution of the results of a series of measurements and can be characterized by experimental standard deviations. Estimates of other components can be based on experience or other information.</p> <p>^a Uncertainty of measurement is an estimate characterizing the range of values within which the true value of the measurement lies, based on a 95 % confidence interval (see ISO/IEC Guide 98-3).</p> <p>^b Can be measured directly or indirectly.</p>	

9.3 Test tolerances for the capacity tests

9.3.1 The maximum permissible variation of any individual observation from a specific test condition during a steady-state capacity test is listed in Table 13. If a test condition is not specified, the values in column 3 of Table 13 represent the greatest permissible difference between maximum and minimum instrument observations during the test. When expressed as a percentage, the maximum allowable variation is the specified percentage of the arithmetical average of the observations.

9.3.2 The maximum permissible variations of the average of the test observations from this International Standard or specified test conditions are show in Table 13.

9.3.3 Under defrost conditions, the normal functioning of the test room reconditioning apparatus may be disturbed. Because of this, the maximum allowable deviation of air temperature readings shall be three times those specified in Table 13.

Table 13 — Variations allowed during steady-state cooling and heating capacity tests

Reading	Variations of arithmetical mean values from specified test conditions	Maximum variation of individual readings from specified test conditions ^a
Temperature of air entering indoor-side:		
— dry-bulb	$\pm 0,3$ °C	$\pm 0,5$ °C
— wet-bulb	$\pm 0,2$ °C ^a	$\pm 0,3$ °C ^a
Temperature of air entering outdoor-side:		
— dry-bulb	$\pm 0,3$ °C	$\pm 0,5$ °C
— wet-bulb	$\pm 0,2$ °C ^b	$0,3$ °C ^b
Voltage	± 1 %	± 2 %
Air volume flow rate ^c	± 5 %	± 10 % ^c
^a Not applicable for heating tests. ^b Only applies to cooling capacity tests if equipment rejects condensate to the outdoor coil. ^c Only applies to the indoor air enthalpy method. The test condition is defined as the measured arithmetical mean of airflow taken within the first 5 min of the data collection period.		

9.4 Test tolerances for performance tests

The maximum allowable variation of any individual observation made during a performance test from the specified test condition is established in Table 14.

Table 14 — Test tolerances for performance tests

Readings	Maximum variation of individual readings from specified test conditions ^a
Air temperatures:	
— dry-bulb	$\pm 1,0$ °C
— wet-bulb	$\pm 0,5$ °C
Voltage	± 2 %
^a The test tolerances do not apply when the equipment is stopped, changing compressor speed or from defrost initiation to 10 min after defrost termination. Except during these intervals, dry-bulb temperature tolerances of $\pm 2,5$ °C on the indoor side and ± 5 °C on the outdoor side shall apply.	

10 Test results

10.1 Capacity calculations

10.1.1 General

The results of a capacity test shall express quantitatively the effects produced upon air by the equipment being tested. For given test conditions, the capacity test results shall include the following quantities as are applicable to cooling or heating:

- a) total cooling capacity, in watts;
- b) sensible cooling capacity, in watts;

- c) latent cooling capacity, in watts;
- d) heating capacity, in watts;
- e) indoor-side airflow rate, in cubic metres per second of standard air;
- f) external resistance to indoor airflow, in pascals;
- g) effective power input to the equipment or individual power inputs to each of the electrical equipment components, in watts.

NOTE For determination of latent cooling capacity, see Annex D if using the calorimeter test method and Annex E if using the indoor air enthalpy test method.

10.1.2 Adjustments

Test results shall be used to determine capacities without adjustment for permissible variations in test conditions. Air enthalpies, specific volumes and isobaric specific heat capacities shall be based on the measured barometric pressure.

10.1.3 Cooling capacity calculations

10.1.3.1 An average cooling capacity shall be determined from the set of cooling capacities recorded over a data collection period of at least 30 min.

10.1.3.2 An average electrical power input shall be determined from the set of electrical power inputs recorded over the data collection period or from the integrated electrical power for the same interval in cases where an electrical energy meter is used.

10.1.3.3 Standard ratings of capacities shall include the effects of circulating-fan heat, but shall not include supplementary heat. For units provided without a fan, the effects to be taken into account shall be calculated according to Annex P.

10.1.4 Heating capacity calculations

10.1.4.1 Steady-state capacity calculations

10.1.4.1.1 If the heating capacity test is conducted in accordance with the provisions of 7.1.9.2 or 7.1.10.4, a heating capacity shall be calculated using data from each data sampling in accordance with Annex D, if using the calorimeter test method, or in accordance with Annex E, if using the indoor air-enthalpy test method.

10.1.4.1.2 An average heating capacity shall be determined from the set of heating capacities recorded over the data collection period.

10.1.4.1.3 An average electrical power input shall be determined from the set of electrical power inputs recorded over the data collection or from the integrated electrical power for the same data collection period.

10.1.4.2 Transient capacity tests

10.1.4.2.1 If the heating capacity test is conducted in accordance with the provisions of 7.1.11, an average heating capacity shall be determined. This average heating capacity shall be calculated as specified in Annex D if using the calorimeter test method and as specified in Annex E if using the indoor air-enthalpy test method.

10.1.4.2.2 For equipment where one or more complete cycles occur during the data collection period, the following shall apply. The average heating capacity shall be determined using the integrated capacity and the elapsed time corresponding to the total number of complete cycles that occurred over the data collection period. The average electrical power input shall be determined using the integrated power input and the

elapsed time corresponding to the total number of complete cycles during the same data collection period as the one used for the heating capacity.

NOTE A complete cycle consists of a heating period and a defrost period from defrost termination to defrost termination.

10.1.4.2.3 For equipment that does not conduct a complete cycle during the data collection period, the following shall apply. The average heating capacity shall be determined using the integrated capacity and the elapsed time corresponding to the total data collection period (3 h if using the indoor air-enthalpy test method; 6 h if using the calorimeter test method). The average electrical power input shall be determined using the integrated power input and the elapsed time corresponding to the same data collection period as the one used for the heating capacity (see Example 2 in Annex Q).

10.1.4.2.4 For equipment in which a single defrost occurs during the test period, the following shall apply. The average heating capacity shall be determined using the integrated capacity and the elapsed time corresponding to the total test period (3 h if using the indoor air-enthalpy test method; 6 h if using the calorimeter test method). The average electrical power input shall be determined using the integrated power input and the elapsed time corresponding to the total test period (see Example 3 in Annex Q).

10.1.5 Power input of fans

The fan power measured during the test shall be included in the declared power consumption and in the calculation of efficiencies. Standard ratings of capacities shall include the effects of circulating-fan heat, but shall not include supplementary heat. For units provided without a fan, the effect of the fan to be taken into account shall be calculated according to Annex P.

10.2 Data to be recorded

The data to be recorded for the capacity tests are given in Table 15 for the indoor air enthalpy test method and Tables 16 and 17 for the room calorimeter test method. The tables identify the general information required but are not intended to limit the data to be obtained. Electrical input values used for rating purposes shall be those measured during the capacity tests.

Table 15 — Data to be recorded for the indoor air-enthalpy capacity tests

No.	Data
1	Date
2	Observers
3	Barometric pressure, in kilopascals
4	Time of tests
5	Power input to equipment ^a , in watts
6	Energy input to equipment ^b , in watt-hours
7	Applied voltage(s), in volts
8	Total current input to equipment, in amperes
9	Frequency, in hertz
10	External resistance to airflow for each indoor unit, in pascals
11	Fan speed setting
12	Setting of variable capacity compressor at full load
13	Dry-bulb temperature of air entering equipment, in degrees Celsius
14	Wet-bulb temperature of air entering equipment, in degrees Celsius
15	Dry-bulb temperature of air leaving measuring device, in degrees Celsius
16	Wet-bulb temperature of air entering measuring device, in degrees Celsius
17	Outdoor dry-bulb and wet-bulb temperatures, in degrees Celsius
18	Volume flow rate of air and all relevant measurements for its calculation, in cubic metres per second
19	Refrigerant charge added by the test house, in kilograms
^a	Total power input and, where required, input to equipment components.
^b	Energy input to equipment is required only during defrost operations.

Table 16 — Data to be recorded for calorimeter cooling capacity tests

No.	Data
1	Date
2	Observers
3	Barometric pressure, in kilopascals
4	Fan speed setting indoor and outdoor
5	Applied voltage, in volts
6	Frequency, in hertz
7	Total current input to equipment, in amperes
8	Total power input to equipment ^a , in watts
9	Setting of variable capacity compressor at full load, control dry-bulb and wet-bulb temperature of air (indoor-side calorimeter compartment) ^b , in degrees Celsius
10	Control dry-bulb and wet-bulb temperature of air (outdoor-side calorimeter compartment) ^b , in degrees Celsius
11	Average air temperature outside the calorimeter if calibrated (see Figure D.1), in degrees Celsius
12	Total power input to indoor-side and outdoor-side compartments, in watts
13	Quantity of water evaporated in humidifier, in kilograms
14	Temperature of humidifier water entering indoor-side and outdoor-side (if used) compartments or in humidifier tank, in degrees Celsius
15	Cooling water flow rate through outdoor-side compartment heat-rejection coil, in litres per second
16	Temperature of cooling water entering outdoor-side compartment, for heat-rejection coil, in degrees Celsius
17	Temperature of cooling water leaving outdoor-side compartment, from heat-rejection coil, in degrees Celsius
18	Temperature of condensed water leaving outdoor-side compartment, in degrees Celsius
19	Mass of condensed water from equipment, in kilograms
20	Volume of airflow through measuring nozzle of the separating partition, in cubic metres per second
21	Air-static pressure difference across the separating partition of calorimeter compartments, in pascals
22	Refrigerant charge added by the test house, in kilograms
<p>^a Total power input to the equipment, except if more than one external power connection is provided on the equipment; record input to each connection separately.</p> <p>^b See D.1.5.</p>	

Table 17 — Data to be recorded for calorimeter heating capacity tests

No.	Data
1	Date
2	Observers
3	Barometric pressure, in kilopascals
4	Fan speed setting indoor and outdoor
5	Applied voltage, in volts
6	Frequency, in hertz
7	Total current input to equipment, in amperes
8	Total power input to equipment ^a , in watts
9	Setting of variable capacity compressor at full load
10	Control dry-bulb and wet-bulb temperature of air (indoor-side calorimeter compartment) ^b , in degrees Celsius
11	Control dry-bulb and wet-bulb temperature of air (outdoor-side calorimeter compartment) ^b , in degrees Celsius
12	Average air temperature outside the calorimeter if calibrated (see Figure D.1), in degrees Celsius

Table 17 (continued)

No.	Data
13	Total power input to indoor-side and outdoor-side compartments, in watts
14	Quantity of water evaporated in humidifier, in kilograms
15	Temperature of humidifier water entering indoor-side and outdoor-side (if used) compartments or in humidifier tank, in degrees Celsius
16	Cooling water flow rate through outdoor-side compartment heat-rejection coil, in litres per second
17	Temperature of cooling water entering outdoor-side compartment, for heat-rejection coil, in degrees Celsius
18	Temperature of cooling water leaving outdoor-side compartment, from heat-rejection coil, in degrees Celsius
19	Mass of condensed water from equipment, in kilograms
20	Temperature of condensed water leaving outdoor-side compartment, in degrees Celsius
21	Volume of airflow through measuring nozzle of the separating partition, in cubic metres per second
22	Air-static pressure difference across the separating partition of calorimeter compartments, in pascals
23	Refrigerant charge added by the test house, in kilograms
a	Total power input to the equipment, except if more than one external power connection is provided on the equipment; record input to each connection separately.
b	See D.1.5.

10.3 Test report

10.3.1 General information

As a minimum, the test report shall contain the following general information:

- a) a reference to this International Standard, i.e. ISO 15042:2011;
- b) the date;
- c) the test institute;
- d) the test location;
- e) the test method(s) used (calorimeter or air-enthalpy);
- f) the test supervisor;
- g) the test object, climate type designation (i.e. T1, T2, T3);
- h) a description of the test set-up, including equipment location;
- i) the nameplate information (see 11.2).

10.3.2 Rating test results

The values reported shall be the mean of the values taken over the data collection period, and shall be stated with an uncertainty of measurement at a confidence level of 95 % and in accordance with ISO/IEC Guide 98-3.

10.3.3 Performance tests

All relevant information regarding testing shall be reported.

11 Marking provisions

11.1 Nameplate requirements

Each individual unit of the air-conditioner and heat pump system shall have a durable nameplate firmly attached to it and in a location accessible for reading.

11.2 Nameplate information

The nameplate shall provide the following minimum information in addition to the information required in international safety standards:

- a) the manufacturer's name or trademark;
- b) any distinctive type or model designation and serial number;
- c) the rated voltage(s);
- d) the rated frequency(ies);
- e) the cooling climate designations and heating rating conditions (i.e. T1, T2, T3, H1, H2, H3, as applicable);
- f) the refrigerant designation in accordance with ISO 817.

11.3 Additional information

In addition to the nameplate information in 11.2, the factory refrigerant mass charge shall be provided on the outdoor unit.

12 Publication of ratings

12.1 Standard ratings

12.1.1 Standard ratings shall be published for cooling capacities (sensible, latent and total), heating capacity, EER and COP, as appropriate, for all systems produced in conformance with this International Standard. These ratings shall be based on data obtained at the established rating conditions in accordance with the provisions of this International Standard.

12.1.2 The values of standard capacities shall be expressed in kilowatts, rounded to three significant figures.

12.1.3 The values of EER and COP shall be expressed in multiples, rounded to three significant figures.

12.1.4 Each capacity rating shall be followed by the corresponding test voltage (see column 2 of Table 3) and frequency rating.

12.2 Other ratings

Additional ratings may be published based on conditions other than those specified as standard rating conditions, or based on conditions specified in national regulations, or based on the testing of various combinations of operating evaporators and/or compressors, if they are clearly specified and if the data are determined by the methods specified in this International Standard, or by analytical methods which are verifiable by the test methods specified in this International Standard.

Annex A (normative)

Airflow settings for ducted units

A.1 General

Two methods of airflow settings are applicable:

- a) fixed duct resistance method;
- b) adjusted exhaust fan setting method.

Both methods with their respective test apparatus are described in this annex.

To measure the static pressure of the discharged air from the ducted equipment, a measuring duct is connected to the duct flange of the equipment. This measuring duct is used for both methods. If the dimensions of the outlet duct section are A and B , the equivalent diameter, D_e , is determined using Equation (A.1):

$$D_e = \sqrt{(4AB)/\pi} \quad (\text{A.1})$$

If the outlet duct is circular in section with diameter D , the equivalent diameter D_e is equal to D .

The length of the measuring duct, L_d , needs to be no smaller than $2,5D_e$. The static pressure taps should be located at the distance $L_m = 2D_e$ from the outlet flange.

A.2 Test method

A.2.1 The flow setting of the units shall be by means of the fixed duct resistance method as shown in Figure A.1 or the adjusted exhaust fan setting method as shown in Figure A.2.

A.2.2 The static pressure measurement taps shall be arranged as shown in Figure A.1 and Figure A.2. The unit under test shall be operated without the compressor running.

A.2.3 Airflow measurements should be made in accordance with the provisions specified in Annex C, as appropriate, as well as other provisions established in this International Standard.

NOTE Additional guidance concerning airflow measurements can be found in ISO 3966 and ISO 5167-1.

A.3 Fixed duct resistance method

A.3.1 General

A measuring duct shall be connected to the test unit and a damper installed on the opposite end of the measuring duct, to which a discharge chamber is connected. The discharge chamber shall have sufficient cross-sectional dimensions so that airflow velocities along the wall surface at the static pressure tap (Figure A.1, item 4) is 1,25 m/s or less. The minimum length of the discharge chamber in the flow direction, J , is, $2D_e$.

NOTE The set-up of the test unit, measuring duct and discharge chamber is illustrated in Figure A.1.

A.3.2 Test procedure

A.3.2.1 Test conditions

The temperature and humidity conditions of the test room shall be within the range specified in 5.2. The test unit shall be operated in the blowing mode without the compressor running. The damper shall be adjusted so that the rated airflow rate in standard air is obtained. At the same time, the airflow rate of the airflow measuring apparatus shall be adjusted so that static pressure in the discharge chamber is (0 ± 2) Pa. The above conditions shall be maintained for at least 1 h.

A.3.2.2 Blowing test

The dry- and wet-bulb temperatures of the inlet air, airflow rate, ESP, p_e , dry- and wet-bulb temperatures in front of the nozzle, and barometric pressure shall be measured. The measured airflow rate, q_m , shall be converted into the standard flow rate, q_s .

A.3.2.3 Evaluation

The ESP, p_e , shall be that specified in 5.2.

A.3.2.4 Cooling and heating tests

The damper's position shall remain fixed at the setting obtained in A.3.2.1 for all cooling and heating tests, which shall be conducted at the respective temperature and humidity conditions. During the cooling and heating tests, the static pressure of the discharge chamber shall be maintained at (0 ± 2) Pa.

The ESP, p_e , of the measuring duct at the cooling and heating tests is for reference only, and does therefore not need to be published. The airflow rate measured when the equipment is operating in the cooling or heating mode is used for calculation of cooling and heating capacities.

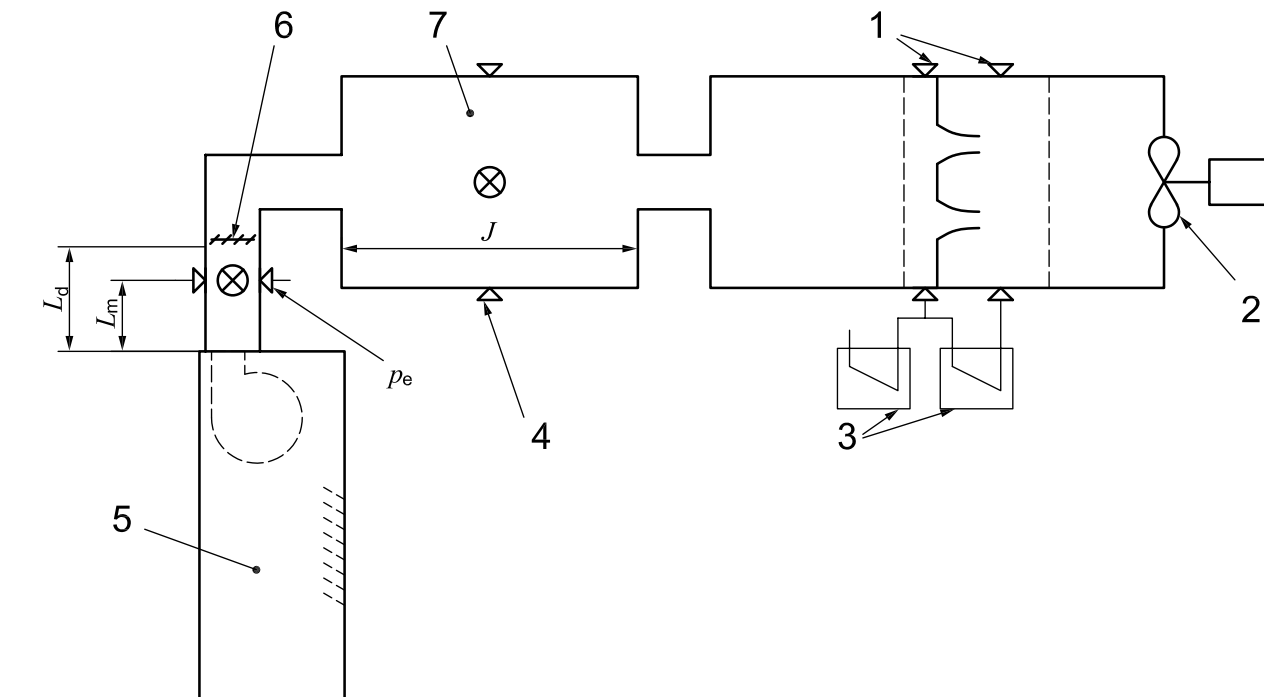

- Key**
- | | | | |
|---|---|-------|----------------------------------|
| 1 | airflow measuring apparatus | 7 | discharge chamber |
| 2 | exhaust fan | J | minimum length |
| 3 | manometers | L_d | length of the measuring duct |
| 4 | static pressure taps of discharge chamber | L_m | distance to static pressure taps |
| 5 | equipment under test | p_e | ESP of the equipment under test |
| 6 | damper | | |

Figure A.1 — Fixed duct resistance method setup

A.4 Adjusted exhaust fan setting method

A measuring duct shall be connected to the test unit and an airflow measuring apparatus connected to the opposite end of the measuring duct.

NOTE The set-up of the test unit, measuring duct and airflow measuring apparatus is illustrated in Figure A.2.

A.4.1 Test procedure

The temperature and humidity conditions of the test room shall be within the range specified in 5.2. The test unit is operated in the blowing mode without the compressor running. The airflow measuring apparatus shall be adjusted so that the rated airflow rate in standard air is obtained. The above conditions shall be maintained for at least 1 h.

A.4.2 Blowing test

The dry- and wet-bulb temperatures of the inlet air, airflow rate, ESP, p_e , dry- and wet-bulb temperatures in front of the nozzle, and barometric pressure shall be measured. The measured airflow rate, q_m , shall be calculated according to Equation (C.6). The measured airflow rate, q_m , shall be converted into the standard flow rate, q_s .

A.4.3 Calculation of the value of C

Calculate the value of C from Equation (A.2).

$$C = \frac{p_m}{q_m^2} \quad (\text{A.2})$$

where p_m is static pressure of the measuring duct, KPa, and p_m is considered to be equal to the external static pressure p_e .

A.4.4 Evaluation

The ESP, p_e , shall be that specified by 5.2.

A.4.5 Cooling and heating tests

Cooling and heating tests shall be performed following the blowing test, at their respective temperature and humidity conditions. The speed of the exhaust fan of the airflow measuring apparatus shall be adjusted for the cooling and heating tests in the following manner.

For the cooling test, operate the equipment with the compressor in the cooling mode and allow the temperature to stabilize. Once the temperature is stabilized adjust the airflow measuring apparatus to achieve the same value of C by changing its exhaust fan speed in small increments. The resulting value of C shall be in the range of $\pm 1\%$ of that measured during the blowing test. Once stabilized, the cooling airflow rate and ESP shall be measured.

For the heating test, repeat the cooling test above, this time with the compressor operating in the heating mode. Measure the heating airflow rate and ESP.

The airflow rate measured when the equipment is operating in the cooling or heating mode shall be used to calculate the cooling and heating capacities.

The ESP of the measuring duct during the cooling and heating tests is for reference only, and does therefore not need to be published.

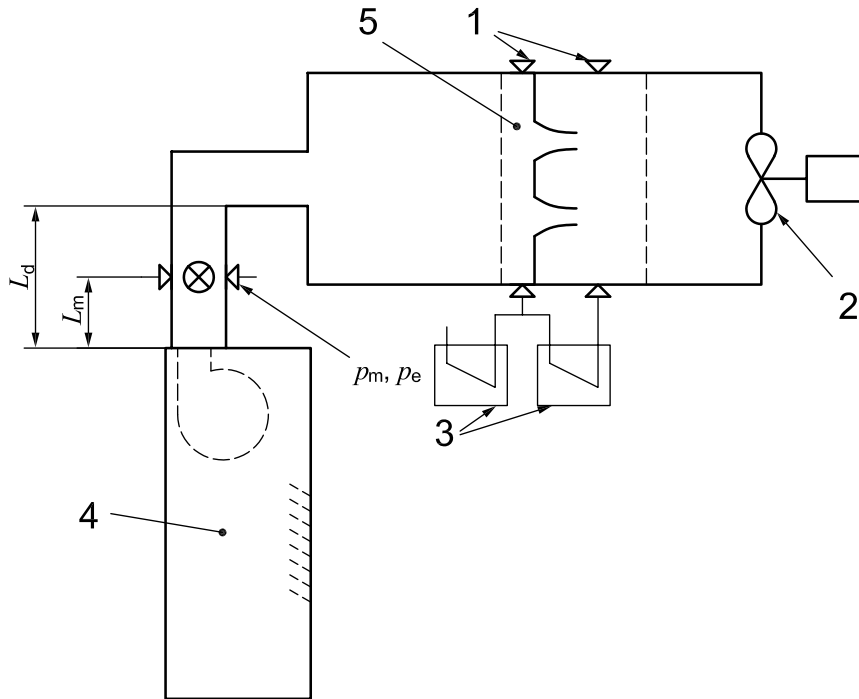

Key

- | | | | |
|---|-----------------------------|-------|---------------------------------------|
| 1 | airflow measuring apparatus | L_d | length of the measuring duct |
| 2 | exhaust fan | L_m | distance to static pressure taps |
| 3 | manometers | p_e | ESP of the equipment under test |
| 4 | equipment under test | p_m | static pressure of the measuring duct |
| 5 | nozzles | | |

Figure A.2 — Adjusted exhaust fan setting method setup

A.5 Unit without indoor fan

If no fan is supplied with the unit, i.e. coil only units, the supplemental requirements given in Annex P also apply.

Annex B (normative)

Test requirements

B.1 General test room requirements

B.1.1 If an indoor condition test room is required, it shall be a room or space in which the desired test conditions can be maintained within the prescribed tolerances. It is recommended that air velocities in the vicinity of the equipment under test do not exceed 2,5 m/s.

B.1.2 If an outdoor condition test room or space is required, it shall be of sufficient volume and shall circulate air in such a manner that it does not change the normal air circulating pattern of the equipment under test. It shall be of such dimensions that the distance from any room surface to any equipment surface from which air is discharged is not less than 1,8 m and the distance from any other room surface to any other equipment surface is not less than 1,0 m, except for floor or wall relationships required for normal equipment installation. The room conditioning apparatus should handle air at a rate not less than the outdoor airflow rate, and should preferably take this air from the direction of the equipment air discharge and return it at the desired conditions uniformly and at low velocities.

B.1.3 If the calorimeter room method is used with a facility having more than two rooms, then the additional rooms shall also comply with the requirements of Annex D. If the air enthalpy method is used with a facility having more than two rooms, then the additional rooms shall also comply with the requirements of Annex E.

B.2 Equipment installation

B.2.1 The equipment to be tested shall be installed in accordance with the manufacturer's installation instructions using recommended installation procedures and accessories. If the equipment can be installed in multiple positions, then all tests shall be conducted in a position specified in the manufacturer's installation instructions. If the equipment can be installed in multiple positions, then all tests shall be conducted using the worst configuration. In all cases, the manufacturer's recommendations with respect to distances from adjacent walls, amount of extensions through walls, etc. shall be followed.

B.2.2 No other alterations to the equipment shall be made except for the attachment of the required test apparatus and instruments in the prescribed manner.

B.2.3 Ducted equipment rated at less than 8 kW and intended to operate at external static pressures of less than 25 Pa shall be tested at free delivery of air (according to ISO 5151).

B.2.4 If necessary, the equipment shall be evacuated and charged with the type and amount of refrigerant specified in the manufacturer's instructions.

B.2.5 All standard ratings for equipment in which the condenser and the evaporator are two separate assemblies shall be determined by manufacturer's specifications within 5 m to 7,5 m of connecting tubing on each line. The lengths shall be actual lengths, not equivalent lengths, and no account shall be taken of the resistance provided by bends, branches, connecting boxes or other fittings used in the installation for the test piece. The length of the connecting tubing shall be measured from the enclosure of the indoor unit to the enclosure of the outdoor unit. Such equipment in which the interconnecting tubing is furnished as an integral part of the unit and not recommended for cutting to length shall be tested with the complete length of tubing furnished. Not less than 40 % of the total length of the interconnecting tubing shall be exposed to the outdoor conditions with the rest of the tubing exposed to the indoor conditions. The line diameters, insulation, details of installation, evacuation and charging shall be in accordance with the manufacturer's published recommendations.

B.3 Static pressure measurements across indoor coil

B.3.1 Equipment with a fan and a single outlet

B.3.1.1 A short plenum shall be attached to the outlet of the equipment. This plenum shall have cross-sectional dimensions equal to the dimensions of the equipment outlets. A static pressure tap shall be added at the centre of each side of the discharge plenum, if rectangular, or at four evenly distributed locations along the circumference of an oval or round plenum. These four static pressure taps shall be manifolded together. The minimum length of the discharge plenum and the location of the static pressure taps relative to the equipment outlets shall be as shown in Figure B.1, if testing a split-system, and as shown in Figure B.2, if testing a single-package unit.

B.3.1.2 A short plenum should be attached to the inlet of the equipment. If used, the inlet plenum shall have the same cross-sectional dimensions as the equipment inlet. In addition, four static pressure taps shall be added and manifolded together. This plenum should otherwise be constructed as shown for the inlet plenum in Figure B.2, if testing a single-package unit, and as shown in Figure B.3, if testing a split-system.

NOTE Figure B.3 is referenced here for guidance even though it specifically applies to ducted units tested without an indoor fan.

B.3.2 Equipment with fans and multiple outlets or multiple indoor units

B.3.2.1 Equipment with multiple outlet duct connections or multiple indoor units shall have a short plenum attached to each outlet connection or indoor unit, respectively. Each of these short plenums shall be constructed as described in B.3.1.1, including static pressure taps. All outlet plenums shall discharge into a single common duct section. For the purpose of equalizing the static pressure in each plenum, an adjustable restrictor shall be located in the plane where each outlet plenum enters the common duct section. Multiple blower units employing a single discharge duct connection flange shall be tested with a single outlet plenum in accordance with B.3.1. Any other test plenum arrangements shall not be used except to stimulate duct designs specifically recommended by the equipment manufacturer.

B.3.2.2 A short plenum should be attached to the inlet of each inlet duct connection or indoor unit. Each of these short plenums shall be constructed as described in B.3.1.2, including static pressure taps.

B.3.3 Equipment without a fan and a single outlet

For an indoor coil that does not incorporate a fan, a short plenum shall be attached to both the inlet and outlet of the equipment. These plenums shall have cross-sectional dimensions equal to the dimensions of the equipment inlet and outlet, respectively. A static pressure tap shall be added at the centre of each side of each plenum, if rectangular, or at four evenly distributed locations along the circumference of oval or round plenums. For each plenum, the four static pressure taps shall be manifolded together. The minimum length of the plenums and the location of the static pressure taps relative to the equipment inlet and outlet shall be as shown in Figure B.3.

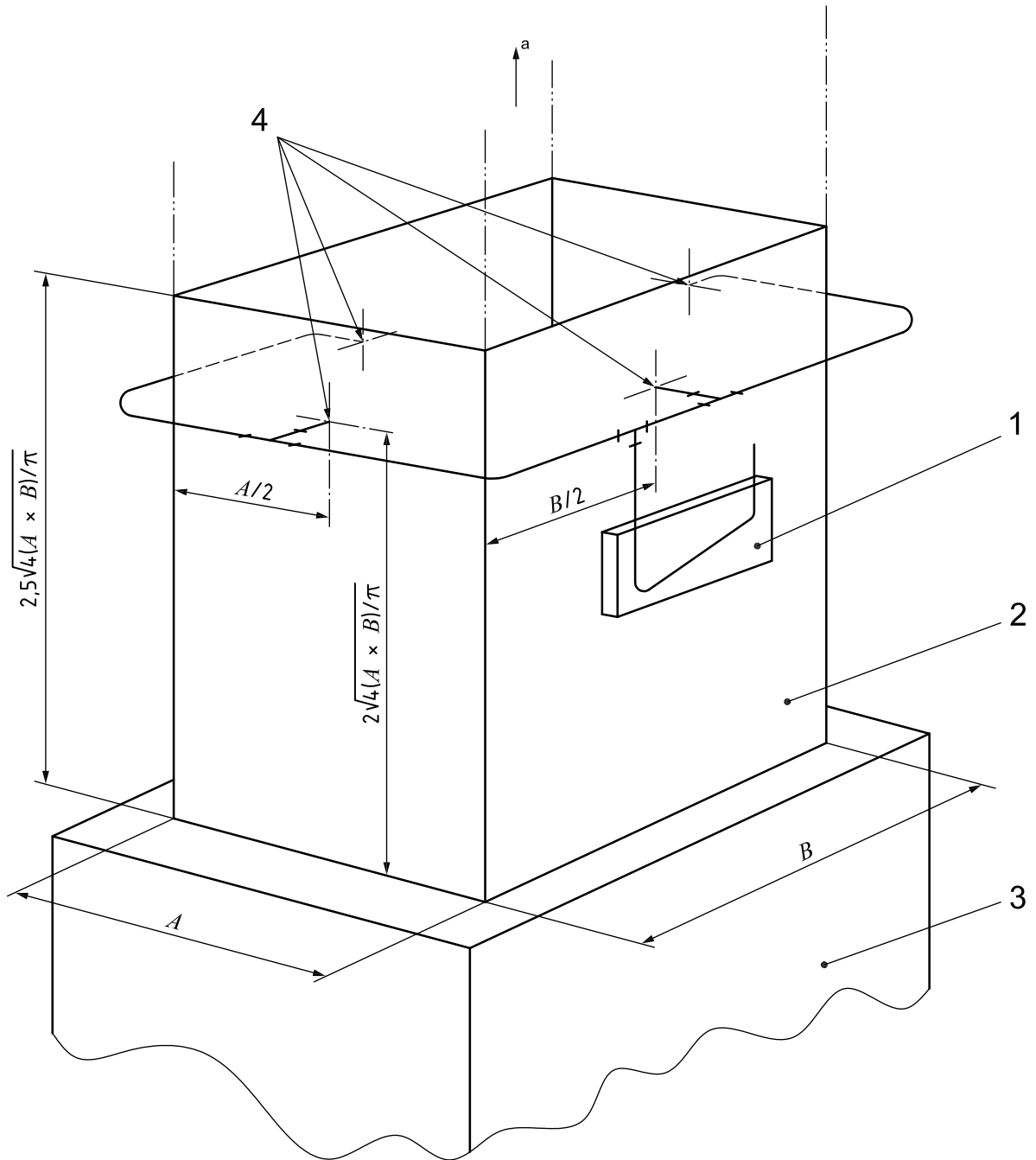

Key

- 1 manometer
- 2 exhaust plenum
- 3 equipment under test
- 4 static pressure taps

^a To airflow measuring apparatus.

NOTE A and B dimensions of equipment under test.

Figure B.1 — ESP measurement

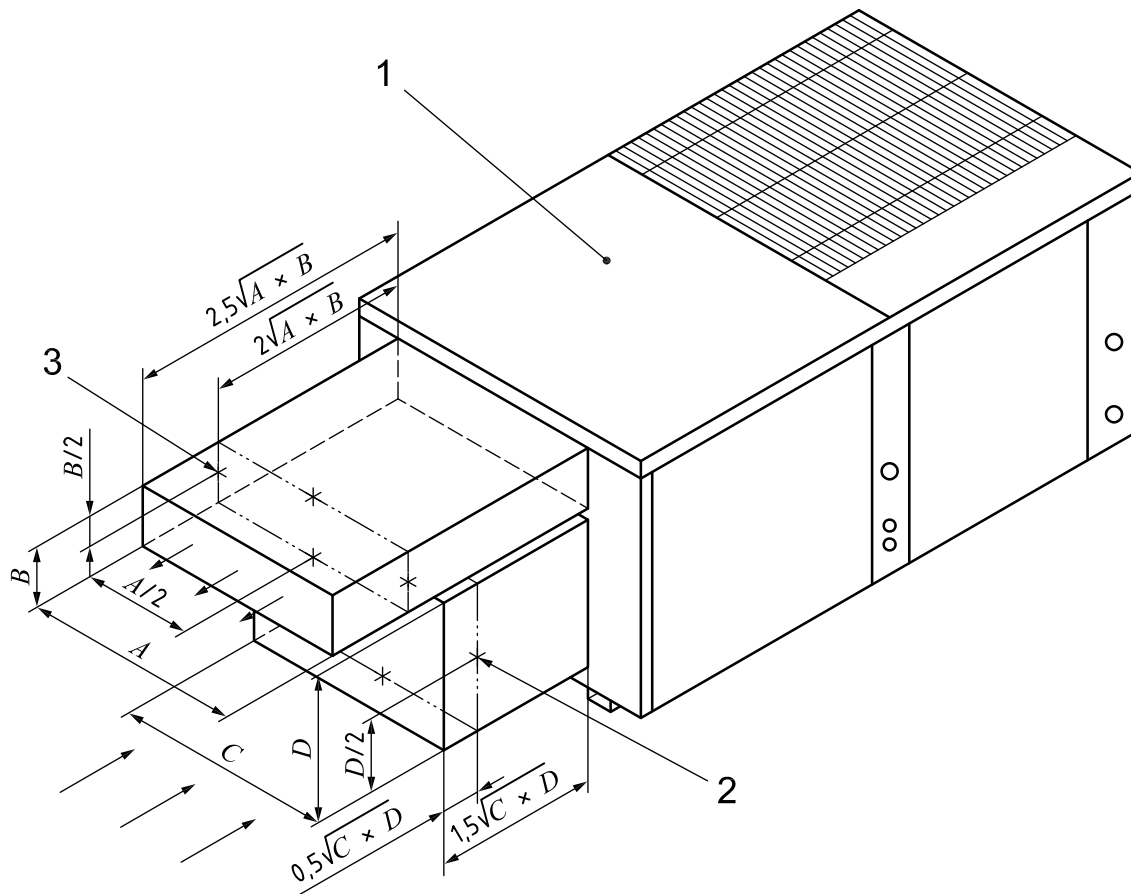
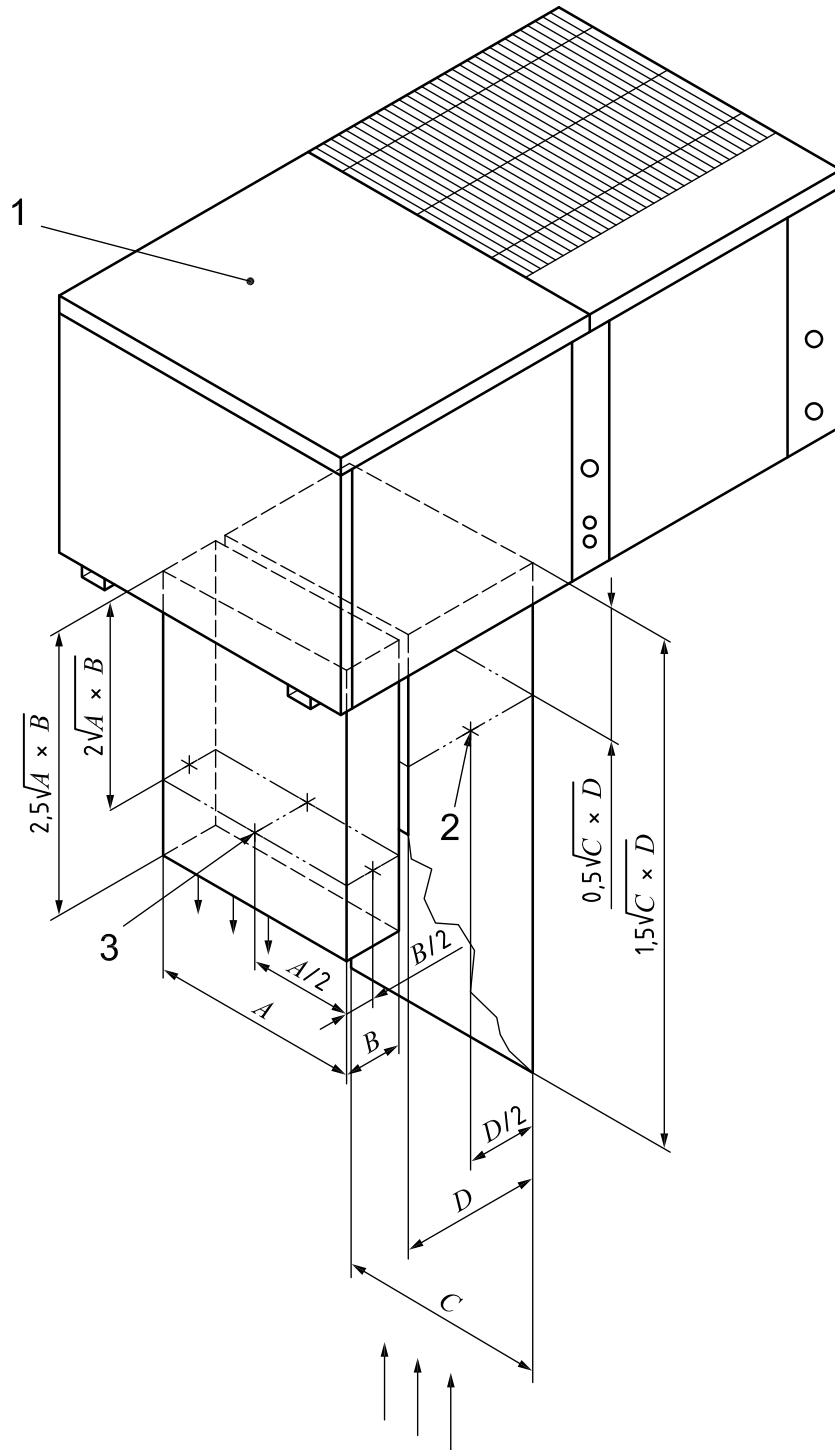

Figure B.2 — ESP measurements (continued)



Key

- 1 equipment under test – single package unit
- 2 static pressure tap, inlet (4 required)
- 3 static pressure tap, outlet (4 required)

NOTE For circular ducts with diameter, D , substitute $\pi d^2/4$ for $(A \times B)$ or $(C \times D)$.

Figure B.2 — ESP measurements

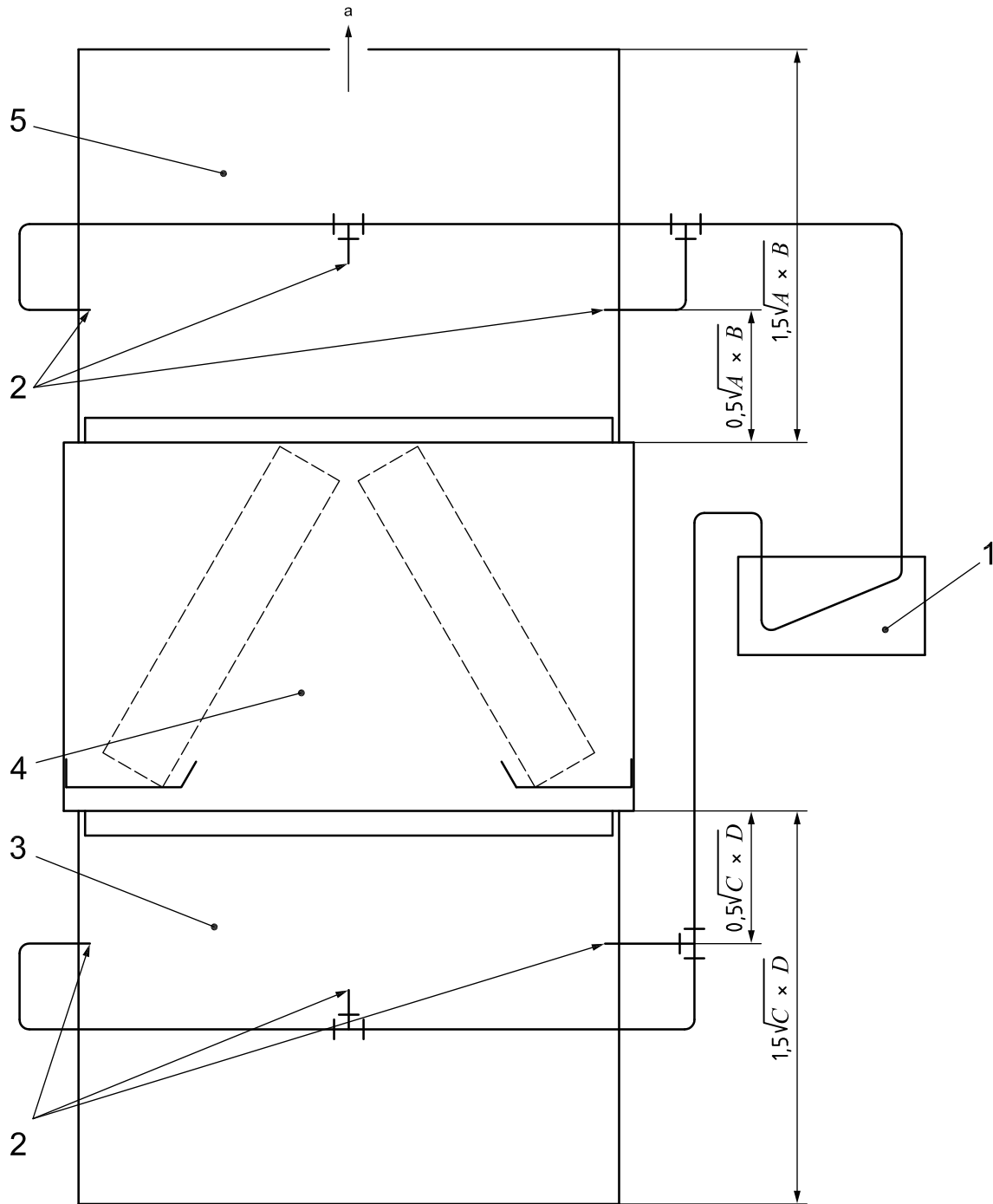

Key

- | | | | | | |
|---|----------------------|---|--------------|---|---------------------------------|
| 1 | manometer | 3 | inlet duct | 5 | outlet duct |
| 2 | outlet pressure taps | 4 | coil section | a | To airflow measuring apparatus. |

NOTE 1 A and B are outlet dimensions, C and D are inlet dimensions.

NOTE 2 For circular ducts with diameter D , substitute $\pi D_i^2/4$ for $(C \times D)$ and $\pi D_o^2/4$ for $(A \times B)$, where D_i is the inlet duct diameter and D_o is the outlet duct diameter.

NOTE 3 The length of the inlet duct, $1,5\sqrt{C \times D}$, is a minimum dimension. For more precise results, use $4\sqrt{C \times D}$.

Figure B.3 — Air-static pressure drop measurement for coil and coil-only unit

Annex C (informative)

Airflow measurement

C.1 Airflow determination

C.1.1 Airflow should be measured using the apparatus and testing procedures given in this annex.

C.1.2 Airflow quantities are determined as mass flow rates. If airflow quantities are to be expressed for rating purposes in volume flow rates, such ratings should state the conditions (pressure, temperature and humidity) at which the specific volume is determined.

C.2 Airflow and static pressure

The area of a nozzle, A_n , should be determined by measuring its diameters to an accuracy of $\pm 0,2\%$ in four locations approximately 45° apart around the nozzle in each of two places through the nozzle throat, one at the outlet and the other in the straight section near the radius.

C.3 Nozzle apparatus

C.3.1 Nozzle apparatus, consisting of a receiving chamber and a discharge chamber separated by a partition in which one or more nozzles are located (see Figure C.1). Air from the equipment under test is conveyed via a duct to the receiving chamber, passes through the nozzle(s), and is then exhausted to the test room or channelled back to the equipment's inlet.

The nozzle apparatus and its connections to the equipment's inlet should be sealed such that air leakage does not exceed 1,0 % of the airflow rate being measured.

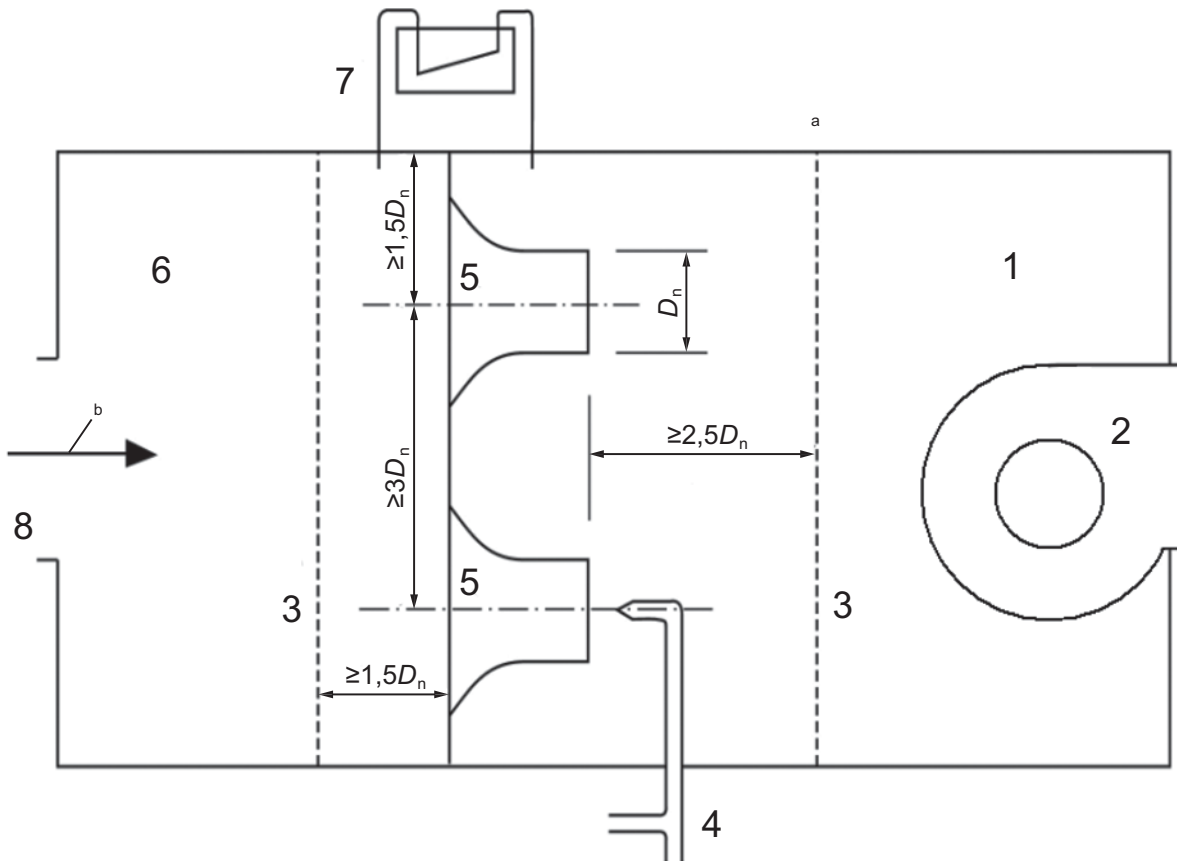

Key

- | | |
|-------------------------|---|
| 1 discharge chamber | 6 receiving chamber |
| 2 exhaust fan | 7 apparatus for differential pressure measurement |
| 3 diffusion baffle | 8 adaptor duct (see C.5.1) |
| 4 Pitot tube (optional) | D_n nozzle throat diameter, mm |
| 5 nozzle | |

- a Diffusion baffles should have uniform perforations, with approximately 40 % of free area.
 b Airflow.

Figure C.1 — Airflow measuring apparatus

The centre-to-centre distance between nozzles in use should be not less than 3 times the throat diameter of the larger nozzle, and the distance from the centre of any nozzle to the nearest discharge or receiving chamber side wall should not be less than 1,5 times its throat diameter.

C.3.2 Diffusers, installed in the receiving chamber (at a distance of at least 1,5 times the largest nozzle throat diameter) upstream of the partition wall and in the discharge chamber (at a distance of at least 2,5 times the largest nozzle throat diameter) downstream of the exit plane of the largest nozzle.

C.3.3 Exhaust fan, capable of providing the desired static pressure at the equipment's outlet; it should be installed in one wall of the discharge chamber and means should be provided to vary the capacity of this fan.

C.3.4 Manometers, for measuring the static pressure drop across the nozzle(s). One end of the manometer should be connected to a static pressure tap located flush with the inner wall of the receiving chamber and the other end to a static pressure tap located flush with the inner wall of the discharge chamber, or, preferably, several taps in each chamber should be connected to several manometers in parallel or manifolded to a single manometer. Static pressure connections should be located so as not to be affected by airflow. Alternatively,

the velocity head of the air stream leaving the nozzle(s) may be measured by a Pitot tube as shown in Figure C.1, but when more than one nozzle is in use, the Pitot tube reading should be determined for each nozzle.

C.3.5 Means for determining the air density at the nozzle throat

C.3.5.1 The throat velocity of any nozzle in use should be not less than 15 m/s and not more than 35 m/s.

C.3.5.2 Nozzles should be constructed in accordance with Figure C.2, and applied in accordance with the provisions of C.3.5.3 and C.3.5.4.

C.3.5.3 Nozzle discharge coefficients, C_d , for the construction shown in Figure C.2, which have a throat-length-to-throat-diameter ratio of 0,6, may be determined using Equation (C.1):

$$C_d = 0,9986 - \frac{7,006}{\sqrt{Re}} + \frac{134,6}{Re} \quad (\text{C.1})$$

for Reynolds numbers, Re , of 12 000 and above.

The Reynolds number is defined as in Equation (C.2):

$$Re = \frac{v_n D_n}{\mu} \quad (\text{C.2})$$

where

v_n is the mean airflow velocity at the throat of the nozzle;

D_n is the diameter of the throat of the nozzle;

μ is the kinematic viscosity of air.

C.3.5.4 Nozzles may also be constructed in accordance with appropriate national standards, provided they can be used in the apparatus described in Figure C.1 and result in equivalent accuracy.

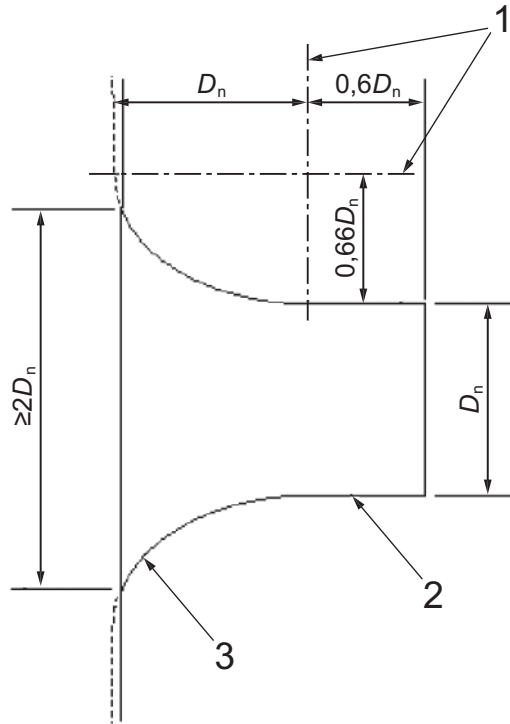

Key

- 1 axes of ellipse
 - 2 throat section
 - 3 elliptical approach
- D_n diameter of nozzle throat, mm

Figure C.2 — Airflow measuring nozzle

C.4 Static pressure measurements

C.4.1 The pressure taps should consist of $(6,25 \pm 0,25)$ mm diameter nipples soldered to the outer plenum surfaces and centred over 1 mm diameter holes through the plenum. The edges of these holes should be free of burrs and other surface irregularities.

C.4.2 The plenum and duct section should be sealed to prevent air leakage, particularly at the connections to the equipment and the air measuring device, and should be insulated to prevent heat leakage between the equipment outlet and the temperature measuring instruments.

C.5 Discharge airflow measurements

C.5.1 The outlet or outlets of the equipment under test should be connected to the receiving chamber by adapter ducting of negligible air resistance, as shown in Figure C1.

C.5.2 To measure the static pressure of the receiving chamber, a manometer should have one side connected to one or more static pressure connections located flush with the inner wall of the receiving chamber.

C.6 Indoor-side airflow measurements

C.6.1 The following readings should be taken:

- a) barometric pressure;
- b) nozzle dry- and wet-bulb temperatures or dew point temperatures;
- c) static pressure difference at the nozzle(s) or, optionally, nozzle velocity pressure.

C.6.2 Air mass flow rate, q_m , through a single nozzle is determined using Equation (C.3):

$$q_m = Y \times C_d \times A_n \sqrt{\frac{2p_v}{V'_n}} \quad (\text{C.3})$$

where p_v is the velocity pressure at the nozzle throat or the static pressure difference across the nozzle.

The expansion factor, Y , is obtained using Equation (C.4):

$$Y = 0,452 + 0,548\alpha \quad (\text{C.4})$$

The pressure ratio, α , is obtained using Equation (C.5):

$$\alpha = 1 - \frac{p_v}{p_n} \quad (\text{C.5})$$

Air volume flow rate through a single nozzle is determined using Equation (C.6):

$$q_V = C_d \times A_n \sqrt{2p_v V'_n} \quad (\text{C.6})$$

where V'_n is calculated using Equation (C.7):

$$V'_n = \frac{v_n}{1 + W_n} \quad (\text{C.7})$$

and W_n is the specific humidity at nozzle inlet.

C.6.3 Airflow through multiple nozzles may be calculated in accordance with C.6.2, except that the total flow rate is then the sum of the q_m or q_V values for each nozzle used.

C.7 Ventilation, exhaust and leakage airflow measurements — Calorimeter test method

C.7.1 Ventilation, exhaust and leakage airflows should be measured using apparatus similar to that illustrated in Figure C.3 with the refrigeration system in operation and after condensate equilibrium has been obtained.

C.7.2 With the equalizing device adjusted for a maximum static pressure differential between the indoor-side and outdoor-side compartments of 1 Pa, the following readings should be taken:

- a) barometric pressure;
- b) nozzle wet- and dry-bulb temperatures;
- c) nozzle velocity pressure.

C.7.3 Airflow values should be calculated in accordance with C.6.2.

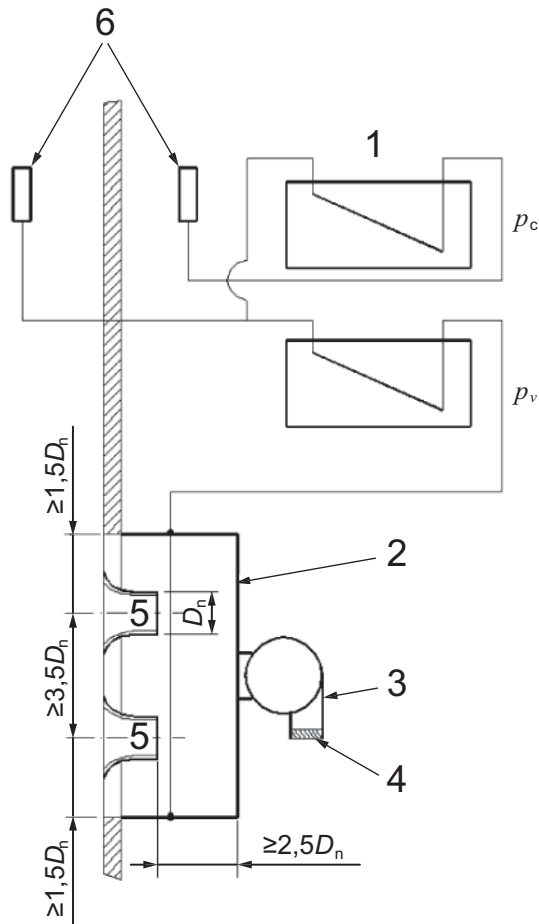

Key

- 1 pressure manometers
- 2 discharge chamber
- 3 exhaust fan
- 4 damper
- 5 nozzle
- 6 pick-up tube
- D_n nozzle throat diameter
- p_c compartment equalization pressure
- p_v nozzle velocity pressure

Figure C.3 — Pressure-equalizing device

Annex D (normative)

Calorimeter test method

D.1 General

D.1.1 The calorimeter provides a method for determining capacity simultaneously on both the indoor side and the outdoor side. In the cooling mode, the indoor-side capacity determination should be made by balancing the cooling and dehumidifying effects with measured heat and water inputs. The outdoor-side capacity provides a confirmative test of the cooling and dehumidifying effect by balancing the heat and water rejection on the condenser side with a measured amount of cooling.

D.1.2 The two calorimeter compartments, indoor side and outdoor side, are separated by an insulated partition having an opening into which the non-ducted, single-packaged equipment is mounted. The equipment should be installed in a manner similar to a normal installation. No effort should be made to seal the internal construction of the equipment to prevent air leakage from the condenser side to the evaporator side or vice versa. No connections or alterations should be made to the equipment which might in any way alter its normal operation.

D.1.3 A pressure-equalizing device as illustrated in Figure C.3 should be provided in the partition wall between the indoor-side and the outdoor-side compartments to maintain a balanced pressure between these compartments and to permit measurement of leakage, exhaust and ventilation air. This device consists of one or more nozzles of the type shown in Figure C.2, a discharge chamber equipped with an exhaust fan, and manometers for measuring compartment and airflow pressures.

Since the airflow from one compartment to the other may be in either direction, two such devices mounted in opposite directions or a reversible device should be used. The manometer pressure pick-up tubes should be so located as to be unaffected by air discharged from the equipment or by the exhaust from the pressure-equalizing device. The fan or blower, which exhausts air from the discharge chamber, should permit variation of its airflow by any suitable means, such as a variable speed drive, or a damper as shown in Figure C.3. The exhaust from this fan or blower should be such that it does not affect the inlet air to the equipment.

The pressure equalizing device should be adjusted during calorimeter tests or airflow measurements so that the static pressure difference between the indoor-side and outdoor-side compartments is not greater than 1,25 Pa.

D.1.4 The size of the calorimeter should be sufficient to avoid any restriction to the intake or discharge openings of the equipment. Perforated plates or other suitable grilles should be provided at the discharge opening of the reconditioning equipment to avoid face velocities exceeding 0,5 m/s. Sufficient space should be allowed in front of any inlet or discharge grilles of the equipment to avoid interference with the airflow. Minimum distance from the equipment to the side walls or ceiling of the compartment(s) should be 1 m, except for the back of console-type equipment, which should be in normal relation to the wall. Ceiling-mounted equipment should be installed at a minimum distance of 1,8 m from the floor. Table D.1 gives the suggested dimensions for the calorimeter. To accommodate peculiar sizes of equipment, it may be necessary to alter the suggested dimensions to comply with the space requirements.

Table D.1 — Sizes of calorimeter

Rated cooling capacity of equipment ^a W	Suggested minimum inside dimensions of each room of calorimeter		
	Width	Height	Length
3 000	2,4	2,1	1,8
6 000	2,4	2,1	2,4
9 000	2,7	2,4	3,0
12 000 ^b	3,0	2,4	3,7

^a All figures are round numbers.

^b Larger capacity equipment will require larger calorimeters.

D.1.5 Each compartment should be provided with reconditioning equipment to maintain specified airflow and prescribed conditions. Reconditioning apparatus for the indoor-side compartment should consist of heaters to supply sensible heat and a humidifier to supply moisture. Reconditioning apparatus for the outdoor-side compartment should provide cooling, dehumidification and humidification. The energy supply should be controlled and measured.

D.1.6 When calorimeters are used for heat pumps, they should have heating, humidifying and cooling capabilities for both rooms (see Figures D.1 and D.2). Other means, such as rotating the equipment, may be used as long as the rating conditions are maintained.

D.1.7 Reconditioning apparatus for both compartments should be provided with fans of sufficient capacity to ensure airflows of not less than twice the quantity of air discharged by the equipment under test in the calorimeter. The calorimeter should be equipped with means of measuring or determining specified wet- and dry-bulb temperatures in both calorimeter compartments.

D.1.8 It is recognized that in both the indoor-side and outdoor-side compartments, temperature gradients and airflow patterns result from the interaction of the reconditioning apparatus and test equipment. Therefore, the resultant conditions are peculiar to, and dependent upon, a given combination of compartment size, arrangement and size of reconditioning apparatus, and the air discharge characteristics of the equipment under test.

The point of measurement of specified test temperatures, both wet- and dry-bulb, should be such that the following conditions are fulfilled.

- a) The measured temperatures should be representative of the temperature surrounding the equipment, and should simulate the conditions encountered in an actual application for both indoor and outdoor sides, as indicated above.
- b) At the point of measurement, the temperature of air should not be affected by air discharged from any piece of the equipment. This makes it mandatory that the temperatures be measured upstream of any recirculation produced by the equipment.
- c) Air sampling tubes should be positioned on the intake side of the equipment under test.

D.1.9 During a heating capacity test, the temperature of the air leaving the indoor-side of the heat pump shall be monitored to determine if its heating performance is being affected by a build-up of ice on the outdoor-side heat exchanger. A single temperature measuring device, placed at the centre of the indoor-air outlet, will be sufficient to indicate any change in the indoor-air discharge temperature caused by a build-up of ice on the outdoor-side heat exchanger.

D.1.10 Interior surfaces of the calorimeter compartments should be of non-porous material with all joints sealed against air and moisture leakage. The access door should be tightly sealed against air and moisture leakage by use of gaskets or other suitable means.

D.1.11 If defrost controls on the heat pump provide for stopping the indoor airflow, provision shall be made to stop the test apparatus airflow to the equipment on both the indoor and outdoor sides during such a defrost period. If it is desirable to maintain operation of the reconditioning apparatus during the defrost period, provision may be made to bypass the conditioned air around the equipment as long as assurance is provided that the conditioned air does not aid in the defrosting. A watt-hour meter shall be used to obtain the integrated electrical input to the equipment under test.

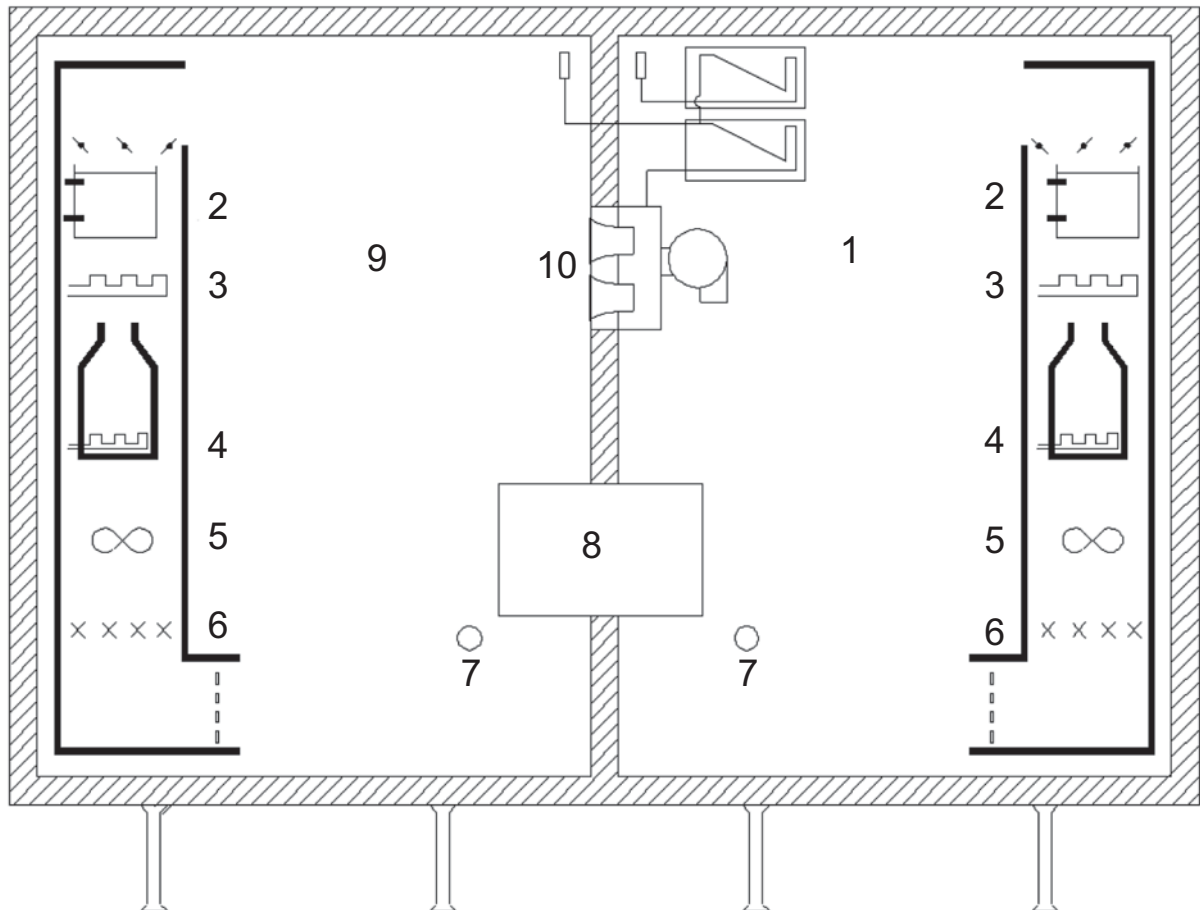

Key

- | | |
|----------------------------|---------------------------------|
| 1 outdoor-side compartment | 6 mixer |
| 2 cooling coil | 7 air sampling tube |
| 3 heating coil | 8 equipment under test |
| 4 humidifier | 9 indoor-side compartment |
| 5 fan | 10 pressure equalization device |

Figure D.1 — Typical calibrated room-type calorimeter

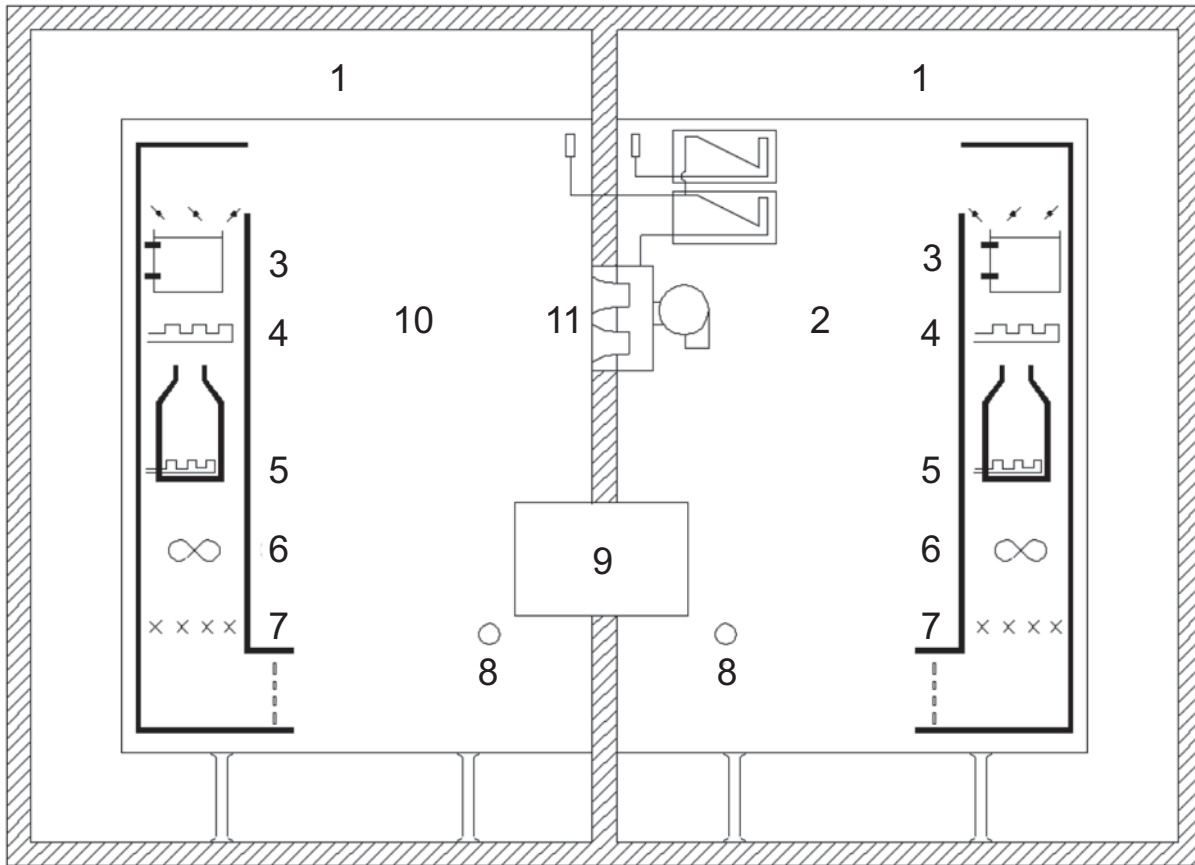

Key

- | | |
|------------------------------------|---------------------------------|
| 1 controlled-temperature air space | 7 mixer |
| 2 outdoor-side compartment | 8 air sampling tube |
| 3 cooling coil | 9 equipment under test |
| 4 heating coil | 10 indoor-side compartment |
| 5 humidifier | 11 pressure equalization device |
| 6 fan | |

Figure D.2 — Typical balanced ambient room-type calorimeter

D.2 Calibrated room-type calorimeter

D.2.1 Heat leakage may be determined in either the indoor-side or outdoor-side compartment by the following method. All openings should be closed. Either compartment may be heated by electric heaters to a temperature of at least 11 °C above the surrounding ambient temperature. The ambient temperature should be maintained constant within ±1 °C outside all six enveloping surfaces of the compartment, including the separating partition. If the construction of the partition is identical to that of the other walls, the heat leakage through the partition may be determined on a proportional area basis.

D.2.2 For calibrating the heat leakage through the separating partition alone, the following procedure may be used. A test is carried out as described above. Then the temperature of the adjoining area on the other side of the separating partition is raised to equal the temperature in the heated compartment, thus eliminating heat leakage through the partition, while the 11 °C differential is maintained between the heated compartment and the ambient surrounding the other five enveloping surfaces.

The difference in heat input between the first test and second test determines the leakage through the partition alone.

D.2.3 For the outdoor-side compartment equipped with means for cooling, an alternative means of calibration may be to cool the compartment to a temperature at least 11 °C below the ambient temperature (on six sides) and carry out a similar analysis.

D.2.4 In addition to the two-room simultaneous method of determining capacities, the performance of the indoor room-side compartment shall be verified at least every six months using an industry standard cooling capacity calibrating device. A calibrating device may also be another equipment whose performance has been measured by the simultaneous indoor and outdoor measurement method at an accredited national test laboratory as part of an industry-wide cooling capacity verification programme.

D.3 Balanced ambient room-type calorimeter

D.3.1 The balanced ambient room-type calorimeter is shown in Figure D.2 and is based on the principle of maintaining the dry-bulb temperatures surrounding the particular compartment equal to the dry-bulb temperatures maintained within that compartment. If the ambient wet-bulb temperature is also maintained equal to that within the compartment, the vapour-proofing provisions of D.1.10 are not required.

D.3.2 The floor, ceiling and walls of the calorimeter compartments shall be spaced a sufficient distance away from the floor, ceiling and walls of the controlled areas in which the compartments are located in order to provide a uniform air temperature in the intervening space. It is recommended that this distance be at least 0,3 m. Means shall be provided to circulate the air within the surrounding space to prevent stratification.

D.3.3 Heat leakage through the separating partition shall be introduced into the heat balance calculation and may be calibrated in accordance with D.2.2 or may be calculated.

D.3.4 It is recommended that the floor, ceiling and walls of the calorimeter compartments be insulated so as to limit heat leakage (including radiation) to no more than 10 % of the test equipment's capacity, for an 11 °C temperature difference, or 300 W for the same temperature difference, whichever is greater, as tested using the procedure given in D.3.2.

D.4 Calculations for cooling capacities

D.4.1 The energy flow quantities used to calculate the total cooling capacity based on indoor-side and outdoor-side measurements are shown below in Figure D.3.

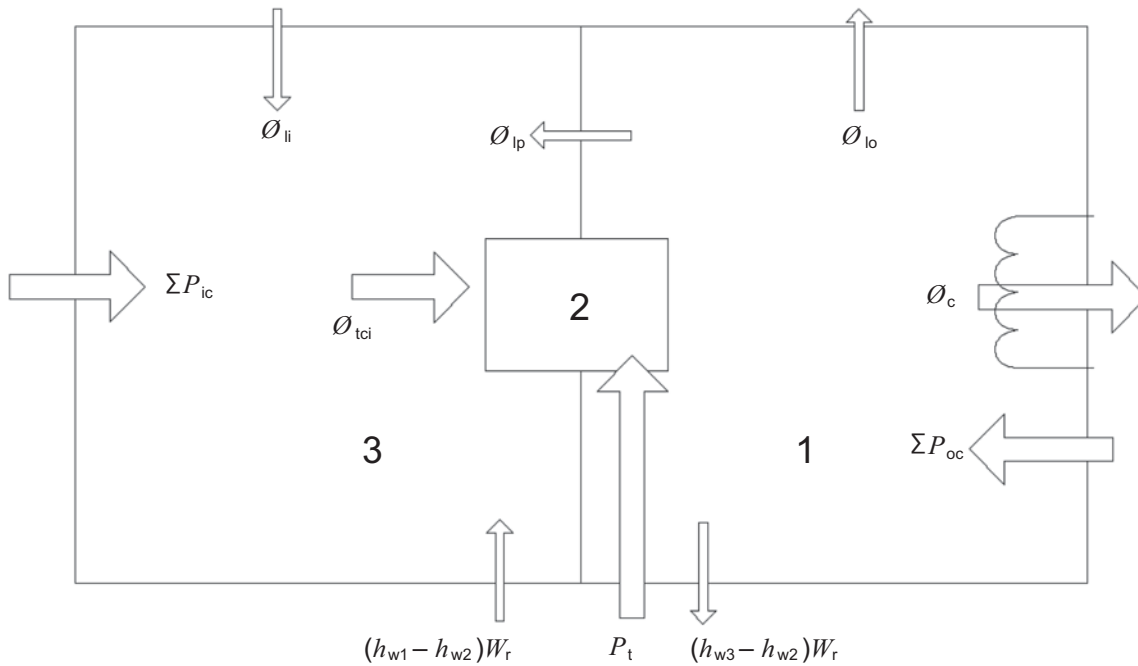

- Key**
- 1 outdoor-side compartment
 - 2 equipment under test
 - 3 indoor-side compartment

NOTE Values for the variables identified in the figure are calculated using the equations in D.4.2 to D.4.10.

Figure D.3 — Calorimeter energy flows during cooling capacity tests

D.4.2 The total cooling capacity on the indoor side, as tested in either the calibrated- or balanced-ambient room-type calorimeter (see Figures D.1 and D.2), is calculated using Equation (D.1):

$$\phi_{tci} = \Sigma P_{ic} + (h_{w1} - h_{w2})W_r + \phi_{ip} + \phi_{ii} \tag{D.1}$$

NOTE If no water is introduced during the test, h_{w1} is taken at the temperature of the water in the humidifier tank of the conditioning apparatus.

D.4.3 When it is not practical to measure the temperature of the air leaving the indoor-side compartment to the outdoor-side compartment, the temperature of the condensate may be assumed to be at the measured or estimated wet-bulb temperature of the air leaving the test equipment.

D.4.4 The water vapour condensed by the equipment under test, W_r , may be determined by the amount of water evaporated into the indoor-side compartment by the reconditioning equipment to maintain the required humidity.

D.4.5 Heat leakage, ϕ_p , into the indoor-side compartment through the separating partition between the indoor-side and outdoor-side compartments may be determined from the calibrating test or, in the case of the balanced-ambient room-type compartment, may be based on calculations.

D.4.6 The total cooling capacity on the outdoor side, ϕ_{tco} , as tested in either the calibrated- or balanced-ambient room-type calorimeter (see Figures D.1 and D.2), is calculated using Equation (D.2):

$$\phi_{tco} = \phi_c - \Sigma P_{oc} - P_t + (h_{w3} - h_{w2})W_r + \phi_p + \phi_o \quad (D.2)$$

NOTE The h_{w3} enthalpy is taken at the temperature at which the condensate leaves the outdoor-side compartment of the reconditioning apparatus.

D.4.7 The heat leakage rate into the indoor-side compartment through the separating partition, ϕ_p , between the indoor-side and outdoor-side compartments may be determined from the calibrating test or, in the case of the balanced-ambient room-type compartment, may be based on calculations.

NOTE This quantity will be numerically equal to that used in Equation (D.1) if, and only if, the area of the separating partition exposed to the outdoor-side is equal to the area exposed to the indoor-side compartment.

D.4.8 The latent cooling capacity (room dehumidifying capacity), ϕ_d , is calculated using Equation (D.3):

$$\phi_d = K_1 W_r \quad (D.3)$$

D.4.9 The sensible cooling capacity, ϕ_{sci} , is calculated using Equation (D.4):

$$\phi_{sci} = \phi_{tci} - \phi_d \quad (D.4)$$

D.4.10 Sensible heat ratio (SHR) is calculated using the following:

$$\phi_{sci} / \phi_{tci}$$

D.5 Calculation of heating capacity

D.5.1 The energy flow quantities used to calculate the total heating capacity based on indoor- and outdoor-side measurements are shown below in Figure D.4.

Copyright International Organization for Standardization

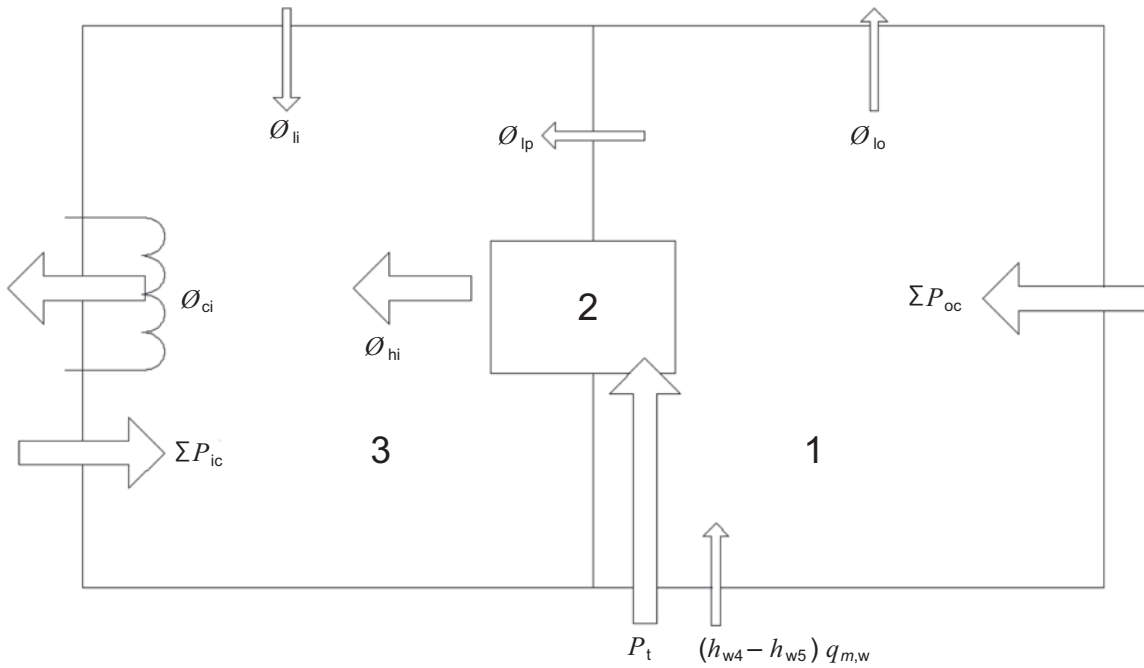

Key

- 1 outdoor-side compartment
- 2 equipment under test
- 3 indoor-side compartment

NOTE Values for the variables identified in this figure are calculated using Equations (D.5) and (D.6).

Figure D.4 — Calorimeter energy flows during heating capacity tests

D.5.2 Determination of the indoor-side heating capacity by measurement in the indoor-side compartment of the calorimeter is calculated using Equation (D.5):

$$\phi_{hi} = \phi_{ci} - \Sigma P_{ic} - \phi_{lp} - \phi_{li} \tag{D.5}$$

NOTE ΣP_{ic} is the other power input to the indoor-side compartment (e.g. illumination, electrical and thermal power input to the compensating device, heat balance of the humidification device), in watts.

D.5.3 Determination of the heating capacity by measurement of the heat-absorbing side, ϕ_{ho} , is calculated for equipment where the evaporator takes the heat from an airflow using Equation (D.6):

$$\phi_{ho} = \Sigma P_{oc} + P_t + (h_{w4} - h_{w5}) q_{m,w} - \phi_{lp} - \phi_{lo} \tag{D.6}$$

where

ΣP_{oc} is the total power input to the outdoor-side compartment with the exception of the power input to the equipment, in watts;

$q_{m,w}$ is the water mass flow supplied to the outside compartment to maintain the test conditions, in kilograms per second;

- h_{w5} is the specific enthalpy of, respectively, the condensed water (in the case of test condition, high) and frost (in the case of test condition, H2 or H3) in the equipment, in joules per kilogram;
- ϕ_o is the heat flow through the remaining enveloping surfaces into the outdoor-side compartment, in watts.

Annex E (normative)

Indoor air enthalpy test method

E.1 General

In the air enthalpy method, capacities are determined from measurements of entering and leaving wet- and dry-bulb temperatures and the associated airflow rate.

E.2 Application

E.2.1 Air leaving the equipment under test shall lead directly to the discharge chamber. If a direct connection cannot be made between the equipment and the discharge chamber, a short plenum shall be attached to the equipment. In this case, the short plenum shall have the same size as the discharge opening of the equipment or shall be constructed so as not to prevent the leaving air from expanding. The cross-section area of the airflow channel through the discharge chamber shall be such that the average air velocity is less than 1,25 m/s against the airflow rate of the equipment under test. The static pressure difference between the discharge chamber and intake opening of the equipment under test shall be zero. An example of the discharge chamber test setup is shown in Figure E.1.

Airflow measurements shall be made in accordance with the provisions specified in Annex C.

NOTE Additional guidance can be found in ISO 3966 and ISO 5167-1, as appropriate, and in the provisions of this annex.

E.2.2 When conducting cooling or steady-state heating capacity tests using the indoor air enthalpy test method, the additional test tolerances given in Table E.1 shall apply.

Table E.1 — Variations allowed during steady-state cooling and heating capacity tests that only apply when using the indoor air enthalpy method

Reading	Variations of arithmetical mean values from specified test conditions	Maximum variation of individual readings from specified test conditions
Temperature of air leaving indoor-side: — dry-bulb	—	$\pm 2,0 \text{ }^\circ\text{C}^a$
External resistance to indoor airflow	$\pm 5 \text{ Pa}$	$\pm 5 \text{ Pa}$

^a The tolerance represents the greatest permissible difference between the maximum and minimum observations during the test.

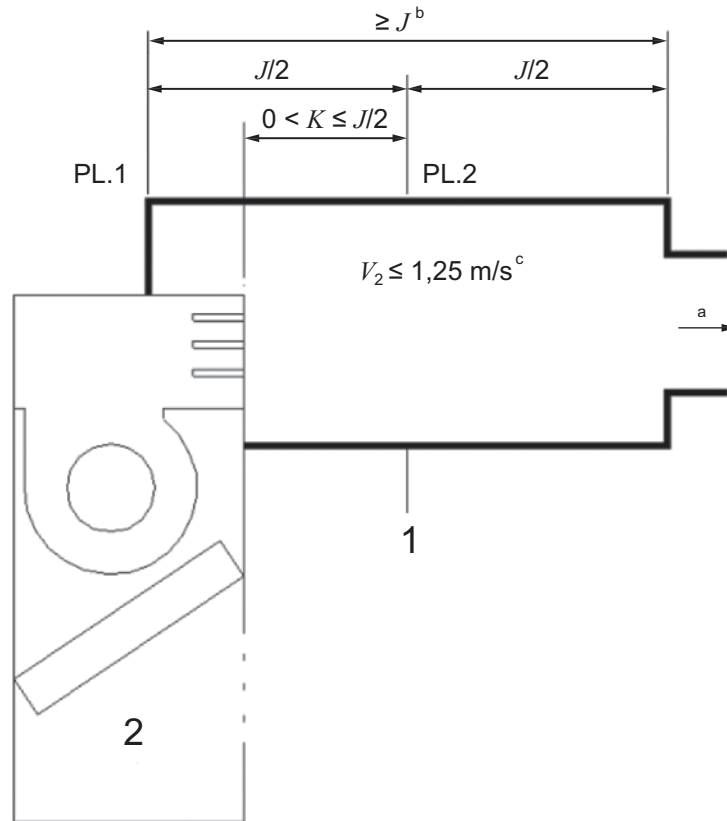

Key

- 1 static pressure tapings
- 2 equipment under test
- a To air sampler and airflow measuring apparatus.
- b $J = 2D_e$, where $D_e = \sqrt{4AB/\pi}$ and A and B are the dimensions of the equipment's air outlet.
- c V_2 is the average air velocity at PL.2.

Figure E.1 — Discharge chamber requirements when using the indoor air enthalpy test method

E.2.3 When conducting transient heating capacity tests using the indoor air enthalpy test method, the additional test tolerances given in Table E.2 shall apply.

Table E.2 — Variations allowed during the transient heating tests that only apply when using the indoor air enthalpy test method

Reading	Variations of arithmetical mean values from specified test conditions		Variation of individual readings from specified test conditions	
	Interval H ^a	Interval D ^b	Interval H ^a	Interval D ^b
External resistance to airflow	±5 Pa	—	±5 Pa	—
NOTE For transient heating tests, see 7.1.11.				
<p>^a Applies when the heat pump is in the heating mode, except for the first 10 min after termination of a defrost cycle.</p> <p>^b Applies during a defrost cycle and during the first 10 min after the termination of a defrost cycle when the heat pump is operating in the heating mode.</p>				

E.3 Calculations for cooling capacities

The total capacity based on the indoor-side test data, ϕ_{tci} , shall be calculated using Equation (E.1):

$$\phi_{\text{tci}} = \frac{q_{V,i}(h_{a1} - h_{a2})}{V_n} = \frac{q_{V,i}(h_{a1} - h_{a2})}{V'_n(1 + W_n)} \quad (\text{E.1})$$

The sensible cooling capacity based on the indoor-side test data, ϕ_{sci} , shall be calculated using Equation (E.2):

$$\phi_{\text{sci}} = \frac{q_{V,i}(c_{\text{pa}1}t_{a1} - c_{\text{pa}2}t_{a2})}{V_n} = \frac{q_{V,i}(c_{\text{pa}1}t_{a1} - c_{\text{pa}2}t_{a2})}{V'_n(1 + W_n)} \quad (\text{E.2})$$

The latent cooling capacity based on the indoor-side test data, ϕ_{d} , shall be calculated using Equation (E.3) or (E.4):

$$\phi_{\text{d}} = \frac{K_1 q_{V,i}(W_{i1} - W_{i2})}{V_n} = \frac{K_1 q_{V,i}(W_{i1} - W_{i2})}{V'_n(1 + W_n)} \quad (\text{E.3})$$

$$\phi_{\text{d}} = \phi_{\text{tci}} - \phi_{\text{sci}} \quad (\text{E.4})$$

E.4 Calculations for heating capacities

Total heating capacity based on indoor-side data, ϕ_{thi} , shall be calculated using Equation (E.5):

$$\phi_{\text{thi}} = \frac{q_{V,i}(c_{\text{pa}2}t_{a2} - c_{\text{pa}1}t_{a1})}{V_n} = \frac{q_{V,i}(c_{\text{pa}2}t_{a2} - c_{\text{pa}1}t_{a1})}{V'_n(1 + W_n)} \quad (\text{E.5})$$

NOTE Equations (E.1), (E.2), (E.3) and (E.5) do not take into consideration heat leakage in the test duct and the discharge chamber.

E.5 Airflow enthalpy measurements

The following test apparatus arrangements are recommended.

E.5.1 Tunnel air enthalpy method

The equipment to be tested is typically located in one or more test rooms. An air measuring device is attached to the equipment air discharge (indoor, outdoor or both, as applicable). This device discharges directly into the test room or space, which is provided with suitable means for maintaining the air entering the equipment at the desired wet- and dry-bulb temperatures (see Figure E.2). Suitable means for measuring the wet- and dry-bulb temperatures of the air entering and leaving the equipment and the external resistance shall be provided.

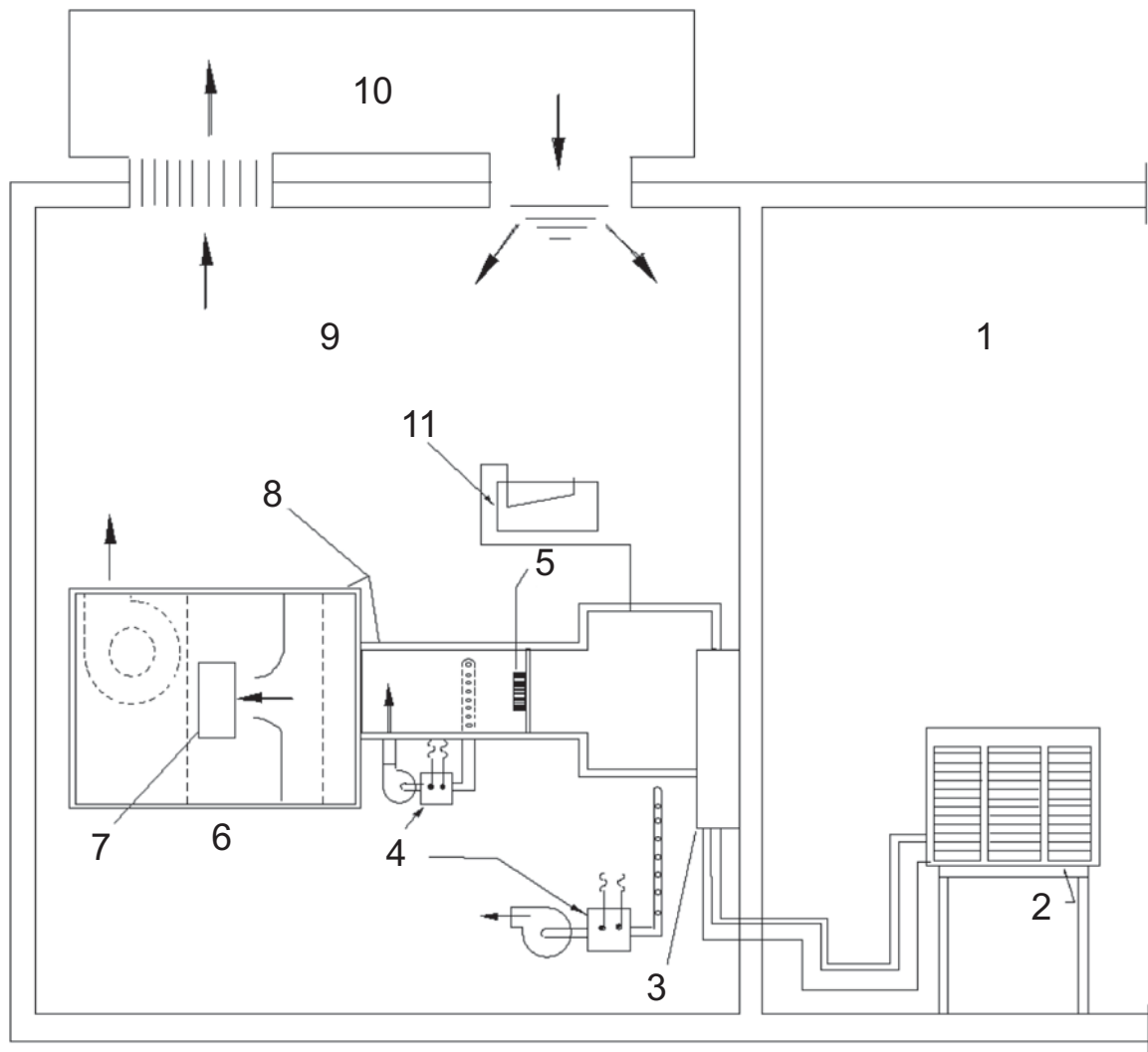

Key

- | | |
|--|--|
| 1 outdoor-side test room | 7 door/window |
| 2 outdoor unit of equipment under test | 8 insulation |
| 3 indoor-side coil section of equipment under test | 9 indoor-side test room |
| 4 air temperature and humidity measuring instruments | 10 room conditioning apparatus |
| 5 mixer | 11 apparatus for differential pressure measurement |
| 6 airflow measuring apparatus | |

Figure E.2 — Tunnel air enthalpy test method arrangement

E.5.2 Loop air enthalpy method

This arrangement differs from the tunnel arrangement in that the air measuring device discharge is connected to suitable reconditioning equipment which is, in turn, connected to the equipment inlet (see Figure E.3). The resulting test “loop” shall be sealed so that air leakage at places that would influence capacity measurements does not exceed 1,0 % of the test airflow rate. The dry-bulb temperature of the air surrounding the equipment shall be maintained within $\pm 3,0$ °C of the desired test inlet dry-bulb temperature. Wet- and dry-bulb temperatures and external resistance are to be measured by suitable means.

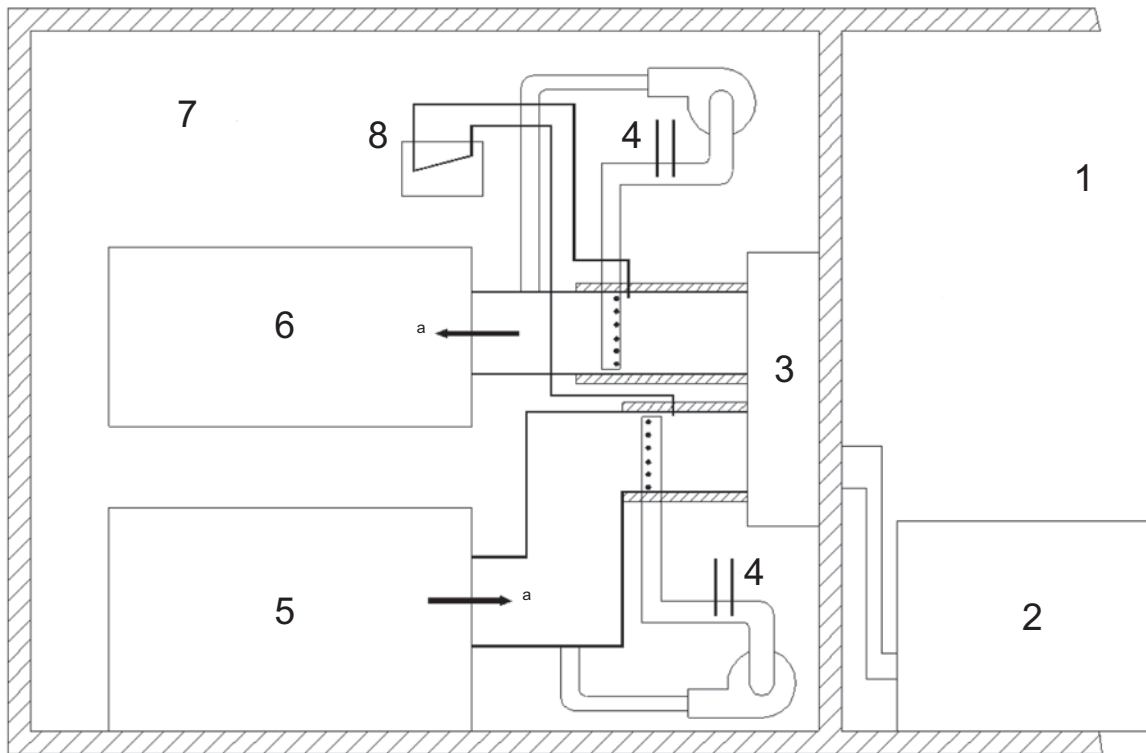

Key

- | | |
|--|---|
| 1 outdoor-side test room | 5 reconditioning apparatus |
| 2 outdoor unit of equipment under test | 6 airflow measuring apparatus |
| 3 indoor unit of equipment under test | 7 indoor-side test room |
| 4 temperature and humidity measuring instruments | 8 apparatus for differential pressure measurement |
| a Airflow. | |

Figure E.3 — Loop air enthalpy test method arrangement

E.6 Calorimeter air enthalpy method

For equipment in which the compressor is ventilated independently of the indoor air stream, the calorimeter air enthalpy method arrangement shall be employed to take into account compressor heat radiation (see Figure E.4). In this arrangement, an enclosure is placed over the equipment, or applicable part of the equipment, under test. This enclosure may be constructed of any suitable material, but shall be non-hydroscopic, airtight and preferably insulated. It shall be large enough to permit inlet air to circulate freely between the equipment and the enclosures and in no case shall the enclosure be closer than 150 mm to any part of the equipment. The inlet to the enclosure shall be remotely located from the equipment's inlet so as to cause circulation throughout the entire enclosed space. An air measuring device is to be connected to the equipment's discharge. This device shall be well insulated where it passes through the enclosed space. Wet- and dry-bulb temperatures of the air entering the equipment are to be measured at the enclosure inlet. Temperature and external resistance measurements shall be carried out by suitable means.

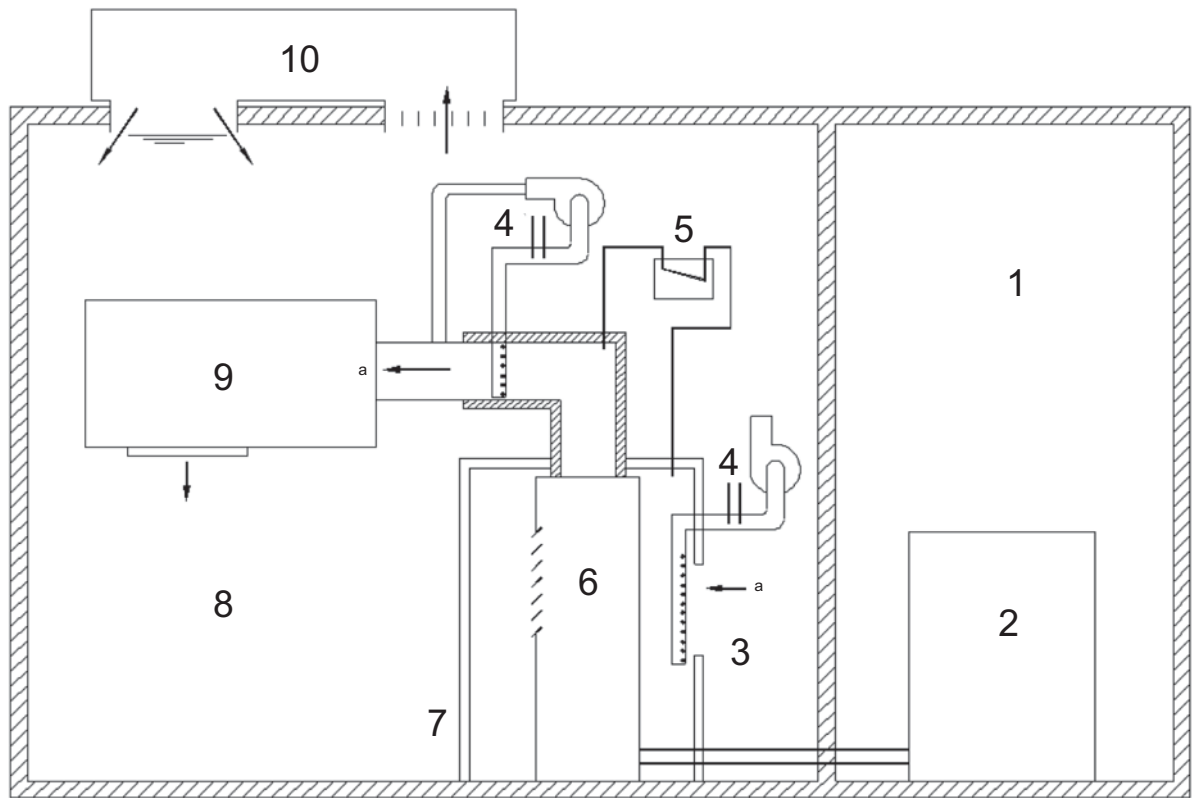

Key

- | | |
|--|--|
| 1 outdoor-side test room | 6 indoor-side coil section of equipment under test |
| 2 outdoor unit of equipment under test | 7 enclosure |
| 3 air inlet | 8 indoor-side test room |
| 4 air temperature and humidity measuring instruments | 9 airflow measuring apparatus |
| 5 apparatus for differential pressure measurement | 10 room conditioning apparatus |
| a Airflow. | |

Figure E.4 — Calorimeter air enthalpy test method arrangement

Copyright International Organization for Standardization

Annex F (informative)

Part-load capacity tests and determination of energy efficiency ratios and coefficients of performance

F.1 General

Part-load capacities and energy efficiency ratios or coefficients of performance are determined in accordance with the provisions specified in 6.1.1 and 7.1.1, except that the capacity ratio of indoor units to outdoor units shall be 0,5 ($\pm 5\%$), by switching off indoor units using the controls provided, if the arrangement of indoor units allows; if not, an alternative ratio shall be selected.

NOTE Other part-load capacities and energy efficiency ratios or coefficients of performance may be determined, if required, at capacity ratios different from 0,5.

F.2 Temperature conditions

Temperature conditions shall be as specified in Table 2 for the cooling test. The heating test shall be conducted at 7 °C dry-bulb and 6 °C wet-bulb outdoor-side conditions and 20 °C dry-bulb and 15 °C wet-bulb indoor-side conditions.

F.3 Airflow conditions

Airflow conditions shall be as specified in Clause 5.

F.4 Test conditions

Test conditions shall be as specified in 6.1.3 and 7.1.3.

F.5 Selection of units

The modular multi-split system shall be selected so that one or a combination of indoor units can be utilized to give the part-load capacity required in 6.1.1.3 and 7.1.1.4.

F.6 Test methods and uncertainty of measurement

Test methods and uncertainty of measurement shall be as specified in Clause 9.

F.7 Test results

Test results shall be recorded and expressed as specified in Clause 10.

F.8 Published ratings

The publication of part-load ratings and energy efficiency ratios or coefficients of performance shall be as specified in Clause 12.

Annex G (informative)

Individual indoor unit capacity tests

G.1 General

The test methods described provide means to determine the capacity of an individual indoor unit, either operating on its own with the other indoor units switched off, or with all indoor units operating.

All tests shall be made in accordance with the requirements of Annex B.

G.2 The calorimeter method

If measurements are made by the calorimeter method, then the testing of an individual unit, with all others operating, will require at least a three-room calorimeter test facility. If only one unit is operating, a two-room calorimeter will suffice. Each calorimeter shall satisfy requirements described in Annex D.

G.3 The air enthalpy method

G.3.1 If measurements are made by the air enthalpy method, then the testing shall be done with one or more indoor rooms and one or more air measuring devices connected to the indoor units. The outdoor unit shall be situated at least in an environmental test room.

G.3.2 The test facility shall satisfy the requirements described in Annex E, except that the individual indoor unit to be tested shall have its own plenum and airflow measuring device.

G.4 Temperature conditions

Temperature conditions shall be as specified in 6.1.2 and 7.1.2.

G.5 Airflow conditions

All air quantities shall be as specified in Clause 5.

G.6 Test conditions

Test conditions shall be as specified in 6.1.3 and from 7.1.4 to 7.1.11.

G.7 Test methods and uncertainty of measurement

Test methods and uncertainty of measurement shall be as specified in Clause 9.

G.8 Test results

Test results shall be recorded and expressed as specified in Clause 10.

G.9 Published ratings

The publication of individual capacities of indoor units shall be as specified in Clause 12. The published results shall specify if all indoor units are operating or only one indoor unit is operating during the test.

Annex H (normative)

Heat recovery test method

H.1 General

The test methods described provide means to determine the total capacity of a heat recovery system as required in Clause 8.

H.2 Three-room calorimeter method

H.2.1 If measurements are made by the calorimeter method, then the testing of a heat recovery system shall need a three-room calorimeter test facility. The indoor units in the cooling mode shall be assembled in one room and the indoor units in the heating mode in the other. The outdoor unit shall be installed in the third room.

H.2.2 Each of the calorimeter rooms shall satisfy the requirements described in Annex D.

H.2.3 For the results to be valid, the sum of the cooling capacity of the indoor units (see D.5.1) and the power input to the compressor and any fans shall differ by not more than 4 % from the sum of the heating capacity of the indoor units (see D.5.1) and the heat from the outdoor unit. The heat from the outdoor unit may be negative if the unit is absorbing heat (see D.5.2), or positive if the unit is rejecting heat (see D.5.2).

H.3 Three-room air enthalpy method

H.3.1 The indoor units in the cooling mode shall be assembled in one room and the indoor units in the heating mode in another room. The outdoor unit shall be installed in the third room.

H.3.2 The test facility shall satisfy the requirements described in Annex E.

H.4 Two-room air enthalpy method

H.4.1 All indoor units, operating either in cooling or heating mode, are assembled in one indoor room. The outdoor unit shall be installed in the other room.

H.4.2 All units operating in the heating mode shall be connected to a common plenum, all units operating in the cooling mode shall be connected to another common plenum, both in accordance with the requirements established in Annex E.

H.5 Test results

Test results shall be recorded and expressed as specified in Clause 10.

H.6 Published ratings

The publication of individual capacities of indoor units shall be as specified in Clause 12.

Annex I (informative)

Compressor calibration test method

I.1 General description

I.1.1 In the compressor calibration test method, total cooling or heating capacity is determined as follows.

- a) From measurements of properties of the refrigerant entering and leaving the indoor-side of the equipment and the associated refrigerant flow rate as determined by subsequent calibration of the compressor under identical operating conditions. Direct capacity measurements should be used when the superheat of the refrigerant leaving the evaporator is less than 3,0 °C.
- b) By measuring capacity directly with a calorimeter when the compressor is operating at the identical conditions encountered during the equipment test.

I.1.2 When the compressor calibration method is employed, the requirements in I.2 and I.3 apply to both the equipment test and the compressor calibration test.

I.1.3 Cooling and heating capacities obtained by the compressor calibration method should include thermal effects of the fan.

I.2 Measurement of refrigerant properties

I.2.1 The equipment should be operated at the desired test conditions, and measurements of the temperature and pressure of the refrigerant entering and leaving the compressor should be recorded at equal intervals that span 5 min or less. These readings should be obtained during the data collection period of the cooling or heating capacity test.

I.2.2 On equipment not sensitive to refrigerant charge, pressure gauges may be tapped into the refrigerant lines.

I.2.3 On equipment sensitive to refrigerant charge, refrigerant pressures should be determined after this test because the connection of pressure gauges might result in a loss of charge. To accomplish this, temperatures are measured during the test by means of thermocouples soldered to return bends at the midpoints of each indoor and outdoor coil circuit or at points not affected by vapour superheat or liquid sub-cooling. Following the test, gauges are connected to the lines and the equipment is evacuated and charged with the type and quantity of refrigerant specified on the nameplate. The equipment is then operated again at test conditions and, if necessary, refrigerant charge is added or removed until the coil thermocouple measurements are within $\pm 0,3$ °C of their original values, the temperatures of the refrigerant vapour entering and leaving the compressor are within $\pm 2,0$ °C of their original values, and the temperature of the liquid entering the expansion device is reproduced within $\pm 0,6$ °C. The operating pressures should then be observed.

I.2.4 Refrigerant temperatures should be measured by means of thermocouples soldered to the lines at appropriate locations.

I.2.5 No thermocouples should be removed, replaced, or otherwise disturbed during any portion of a complete capacity test.

I.2.6 Temperatures and pressures of the refrigerant vapour entering and leaving the compressor should be measured in the refrigerant lines approximately 250 mm from the compressor shell. If the reversing valve is included in the calibration, these data should be taken on the lines to the coils and approximately 250 mm from the valve.

I.3 Compressor calibration

I.3.1 The refrigerant flow rate should then be determined from the calibration of the compressor at the predetermined compressor, entering and leaving refrigerant pressures and temperatures, by one of the primary test methods described in the ISO 917.

I.3.2 Calibration tests should be performed with the compressor and reversing valve (where used) at the same ambient temperature and air pattern as in the tested equipment.

I.3.3 The refrigerant flow, q_r , is calculated using Equation (I.1):

$$q_r = \phi_{tci} / (h_{g1} - h_{f1}) \quad (I.1)$$

for the:

- a) secondary refrigerant calorimeter method;
- b) flooded system primary refrigerant calorimeter method;
- c) dry system primary refrigerant calorimeter method;
- d) concentric tube calorimeter method.

I.3.4 The gaseous refrigerant flow meter method gives refrigerant flow directly.

I.3.5 Total cooling capacity is calculated as prescribed in I.5.1 and I.5.2. Total heating capacity is calculated as prescribed in I.6.

I.4 Direct heating capacity measurements

I.4.1 For compressor calibration tests, when the evaporator superheat on the heating cycle is less than 3,0 °C, the refrigerant flow rate should be determined using the heat rejection from the calorimeter condenser. A water-cooled condenser, insulated against heat leakage, is required. The condenser may be used with any of the calorimeter arrangements in I.3.3.

I.4.2 This method may be used only when the calculated heat leakage from the condenser to the ambient is less than 2 % of the refrigerating effect of the compressor.

I.4.3 The compressor calibration test should be run as specified in I.3. Additional data required are:

- a) refrigerant pressure and temperature entering the condenser;
- b) refrigerant pressure and temperature leaving the condenser;
- c) water temperatures entering and leaving the condenser;
- d) ambient temperature surrounding the condenser;
- e) quantity of condenser cooling water;
- f) average temperature of the condenser jacket surface exposed to ambient.

I.4.4 The refrigerant flow rate, q_r , is calculated using Equation (I.2):

$$q_r = \left[q_w c_{pw} (t_{w1} - t_{w2}) + A_l (t_c - t_a) \right] / (h_{g2} - h_{f2}) \quad (I.2)$$

I.4.5 The total heating capacity, ϕ_{thi} , is calculated as given in I.6.

I.5 Calculations for cooling capacities

I.5.1 For tests in which the evaporator superheat is 3,0 °C or more, total cooling capacity based on compressor calibration data is calculated from the refrigerant flow rate using Equation (I.3):

$$\phi_{tci} = q_r (h_{r2} - h_{r1}) - P_t \quad (I.3)$$

I.5.2 For tests in which the evaporator superheat is less than 3,0 °C, total cooling capacity is calculated using Equation (I.4):

$$\phi_{tci} = \phi_e + A_l (t_a - t_c) - P_l \quad (I.4)$$

I.6 Calculations for heating capacities

The total heating capacity, ϕ_{thi} , based on compressor calibration data is calculated from the refrigerant flow rate using Equation (I.5):

$$\phi_{thi} = q_r (h_{r1} - h_{r2}) - P_l \quad (I.5)$$

Annex J (informative)

Refrigerant enthalpy test method

J.1 General

J.1.1 In this method, capacity is determined from the refrigerant enthalpy change and flow rate. Enthalpy changes are determined from measurements of entering and leaving pressures and temperatures of the refrigerant, and the flow rate is determined by a suitable flow meter in the liquid line.

J.1.2 This method may be used for tests of equipment in which the refrigerant charge is not critical and where normal installation procedures involve the field connection of refrigerant lines.

J.1.3 This method should neither be used for tests in which the refrigerant liquid leaving the flow meter is sub-cooled less than 2,0 °C nor for tests in which the superheat of the vapour leaving the indoor side is less than 3,0 °C.

J.2 Refrigerant flow method

J.2.1 The refrigerant flow rate should be measured with an integrating-type flow meter connected in the liquid line upstream of the refrigerant control device. This meter should be sized such that its pressure drop does not exceed the vapour pressure change that a 2,0 °C temperature change would produce.

J.2.2 Temperature and pressure measuring instruments and a sight glass should be installed immediately downstream of the meter to determine if the refrigerant liquid is adequately sub-cooled. Sub-cooling of 2,0 °C and the absence of any vapour bubbles in the liquid leaving the meter are considered adequate. It is recommended that the meter be installed at the bottom of a vertical downward loop in the liquid line to take advantage of the static head of the liquid thus provided.

J.2.3 At the end of the test, a sample of the circulating refrigerant and oil mixture may be taken from the equipment and its percentage of oil, c_o , calculated using Equation (J.1):

$$c_o = \frac{m_5 - m_1}{m_3 - m_1} \quad (\text{J.1})$$

The total indicated flow rate should be corrected for the amount of oil circulating.

J.3 Refrigerant temperature and pressure measurements

The temperature of the refrigerant entering and leaving the indoor side of the equipment should be measured with instruments having an accuracy of $\pm 0,1$ °C. The pressure of the refrigerant entering and leaving the indoor side of the equipment should be measured with instruments having an accuracy of $\pm 2,0$ % of the indicated value.

J.4 Calculation of cooling capacity

The total cooling capacity, ϕ_{tci} , based on volatile refrigerant flow data is calculated using Equation (J.2):

$$\phi_{\text{tci}} = X_r q_{\text{ro}} (h_{\text{r2}} - h_{\text{r1}}) - P_i \quad (\text{J.2})$$

J.5 Calculation of heating capacity

The total heating capacity, ϕ_{thi} , based on volatile refrigerant flow data is calculated using Equation (J.3):

$$\phi_{\text{thi}} = X_r q_{\text{ro}} (h_{\text{r1}} - h_{\text{r2}}) + P_i \quad (\text{J.3})$$

Annex K (informative)

Outdoor air enthalpy test method

K.1 General

K.1.1 In the air enthalpy method, capacities are determined from measurements of entering and leaving wet- and dry-bulb temperatures and the associated airflow rate.

K.1.2 Outdoor air enthalpy tests are subject to the apparatus arrangement limitations specified in K.2.1. Additional provisions apply if the compressor is independently ventilated (see K.2.2). Line loss adjustment permitted by K.4.3 may be made if the equipment employs remote outdoor coils.

K.2 Test room requirements

K.2.1 When the air enthalpy method is employed for outdoor-side tests, it should be ascertained whether the attachment of the airflow measuring device changes the performance of the equipment being tested and, if so, corrections should be made for this change (see Figure K.1). To accomplish this, the equipment should have thermocouples soldered to return bends at approximately the midpoints of each indoor and outdoor coil circuit. Equipment not sensitive to refrigerant charge may, alternatively, be provided with pressure gauges connected to access valves or tapped into the suction and discharge lines. The equipment should then be operated at the desired conditions, with the indoor-side test apparatus connected but not the outdoor-side apparatus. Data should be recorded at 10 min intervals for a period of not less than 30 min after equilibrium has been attained. The outdoor-side test apparatus should then be connected to the equipment and the pressure or temperatures indicated by the aforementioned gauges or thermocouples noted. If, after equilibrium is again attained, these do not average within $\pm 0,3$ °C or its pressure equivalent of the averages observed during the preliminary test, the outdoor airflow rate should be adjusted until the specified agreement is attained. The test should be continued for a period of 30 min after equilibrium has been attained at the proper conditions, with the outdoor test apparatus connected, and the indoor-side test results during this interval should agree within $\pm 2,0$ % with the results obtained during the preliminary test period. This applies to both the cooling and the heating cycle, but needs to be done at any one condition for each.

K.2.2 For equipment in which the compressor is ventilated independently of the outdoor air stream, the calorimeter air enthalpy method arrangement should be employed to take into account compressor heat radiation (see Figure K.1).

K.2.3 When the outdoor airflow is adjusted as described in K.2.1, the adjusted airflow rate is employed in the capacity calculation. In such cases, however, the outdoor fan power input observed during the preliminary tests should be used for rating purposes.

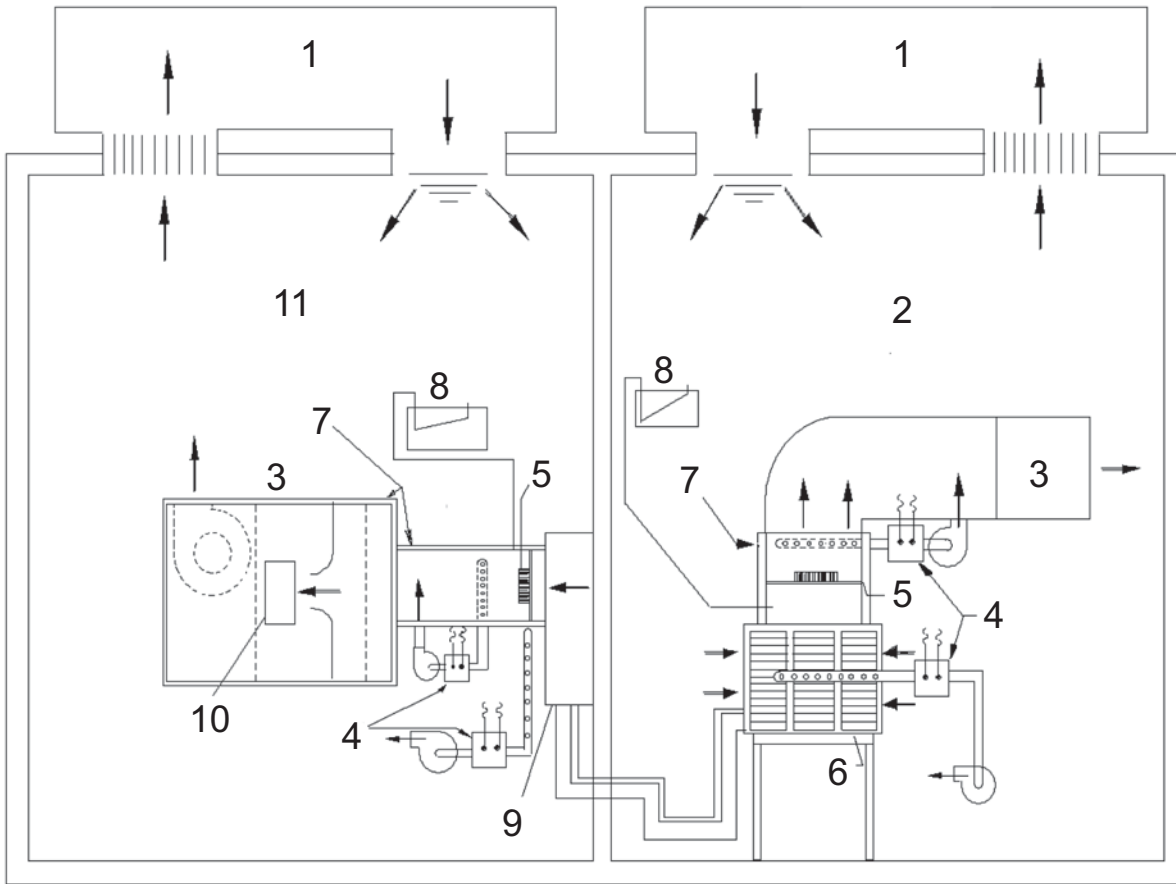

Key

- | | |
|--|--|
| 1 room conditioning apparatus | 7 insulation |
| 2 outdoor-side test room | 8 apparatus for differential pressure measurement |
| 3 airflow measuring apparatus | 9 indoor-side coil section of equipment under test |
| 4 air temperature and humidity measuring instruments | 10 door/window |
| 5 mixer | 11 indoor-side test room |
| 6 outdoor unit of equipment under test | |

Figure K.1 — Outdoor air enthalpy test method arrangement

K.3 Testing conditions

When the outdoor air enthalpy method is used, the requirements in 6.1.3.1 apply to both the preliminary test (see K.2.1) and the regular equipment test.

K.4 Calculations

K.4.1 The total indoor cooling capacity based on outdoor-side data, ϕ_{tci} , is calculated using Equation (K.1):

$$\phi_{tci} = \frac{q_{V,o} (c_{pa4} t_{a4} - c_{pa3} t_{a3})}{V'_n (1 + W_n) - P_t} \tag{K.1}$$

K.4.2 The total heat capacity based on outdoor-side data, ϕ_{tho} , is calculated using Equation (K.2):

$$\phi_{\text{tho}} = \frac{q_{V,o}(h_{a3} - h_{a4})}{V'_n(1+W_n) + P_K} \quad (\text{K.2})$$

K.4.3 If line loss corrections are to be made, they should be included in the capacity calculations. Allowance should be made using Equation (K.3):

$$\phi_L = \left(\frac{1}{R_1 + R_2} \right) L(\Delta t) \quad (\text{K.3})$$

where

$$R_1 = \frac{\ln\left(\frac{0,5D_t + t}{0,5D_t}\right)}{2\pi\lambda} = \frac{1}{2\pi\lambda} \ln\left(1 + \frac{2t}{D_t}\right);$$

$$R_2 = \frac{1}{\pi(D_t + 2t)\alpha_a}.$$

Δt is the temperature difference between the inside and outside of the tube.

Annex L (informative)

Indoor calorimeter confirmative test method

L.1 General

L.1.1 This annex provides a test method for confirming the test results when the cooling and heating capacities are determined by the indoor air enthalpy test method.

L.1.2 In this test method, confirmation should be carried out in the test room specified in L.2 using the measuring method specified in L.3.

L.2 Test room requirements

A recommended test room is shown in Figure L.1. This test room should be constructed such that the air enthalpy test apparatus is installed in the indoor-side compartment of the calorimeter described in Annex D. The calorimeter should be of either the calibrated-room type or the balanced-ambient room type. The air enthalpy test apparatus should be equipped with means of not only measuring airflow rate and enthalpies at the inlet and outlet of the equipment under test but also means for measuring the total power input to the air-enthalpy test apparatus. It is recommended that air leaving the air-enthalpy test apparatus lead to the vicinity of the intake opening of the reconditioning apparatus of the calorimeter.

L.3 Measurement

L.3.1 Measurements should be made 1 h after attaining equilibrium conditions.

L.3.2 Simultaneous measurements made by the calorimeter and the air enthalpy test apparatus should be made in accordance with the methods specified. The cooling capacity determined by measurements using the calorimeter should be calculated in accordance with Equation (D.1), and the heating capacity should be calculated in accordance with Equation (D.5). Likewise, the cooling capacity determined by measurements with the air enthalpy test apparatus is calculated in accordance with Equation (E.3), and the heating capacity in accordance with Equation (E.5).

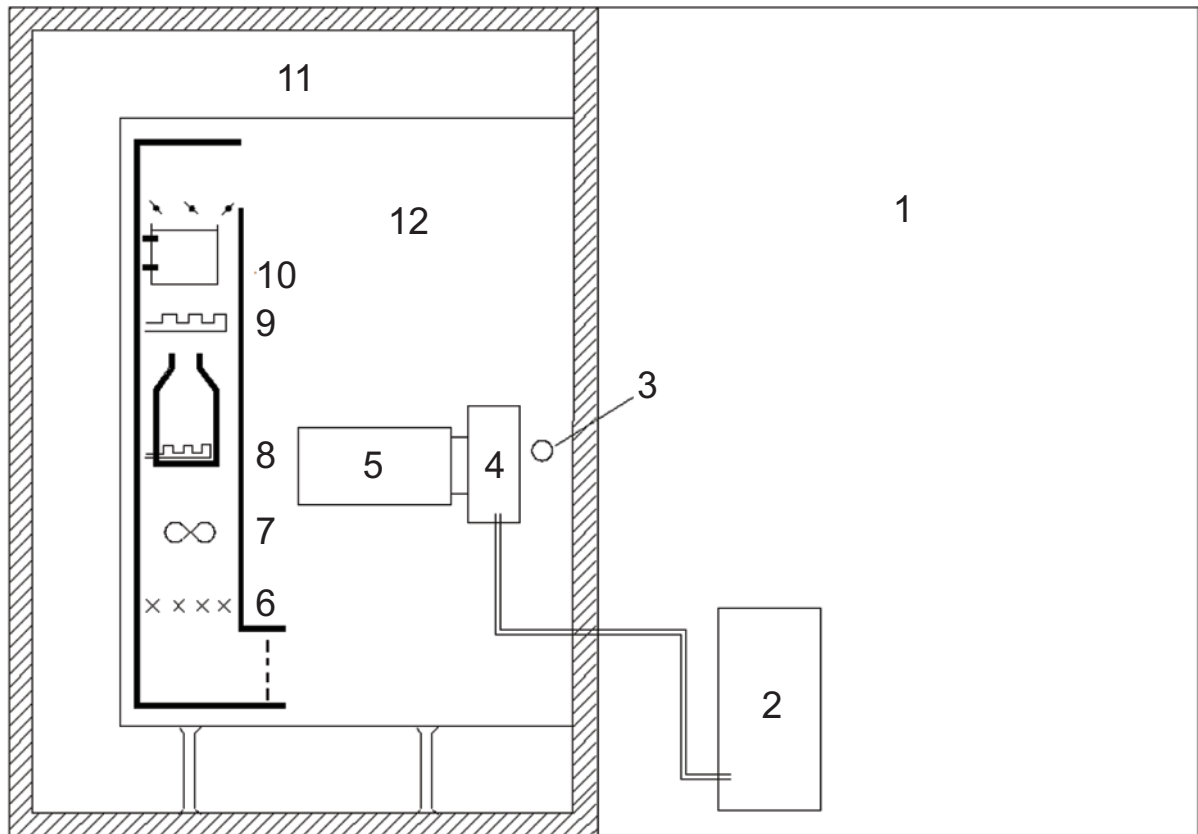

Key

- | | |
|---------------------------------------|-------------------------------------|
| 1 outdoor-side compartment | 7 fan |
| 2 equipment under test – outdoor unit | 8 humidifier |
| 3 air-sampling tube | 9 heating coil |
| 4 equipment under test – indoor unit | 10 cooling coil |
| 5 airflow measuring apparatus | 11 controlled-temperature air space |
| 6 mixer | 12 indoor-side compartment |

Figure L.1 — Indoor calorimeter test method arrangement

Annex M (informative)

Outdoor calorimeter confirmative test method

M.1 General

M.1.1 This annex provides a test method for confirming the test results when the cooling and heating capacities are determined by the indoor air enthalpy test method.

M.1.2 In this test method, confirmation should be made in the test room specified in M.2 using the measuring method specified in M.3.

M.2 Test room requirements

The air enthalpy test apparatus in the indoor-side compartment should be constructed in accordance with this International Standard. The outdoor-side apparatus is the calorimeter, which should be constructed and equipped with the measuring means described in Annex D. A recommended test room is shown in Figure M.1.

M.3 Measurement

M.3.1 Measurements should be made 1 h after attaining equilibrium conditions.

M.3.2 Simultaneous measurements should be made using the air enthalpy apparatus on the indoor side and the calorimeter on the outdoor side in accordance with the methods specified. The cooling capacity determined by measurements using the calorimeter should be calculated in accordance with Equation (D.2), and the heating capacity should be calculated in accordance with Equation (D.6).

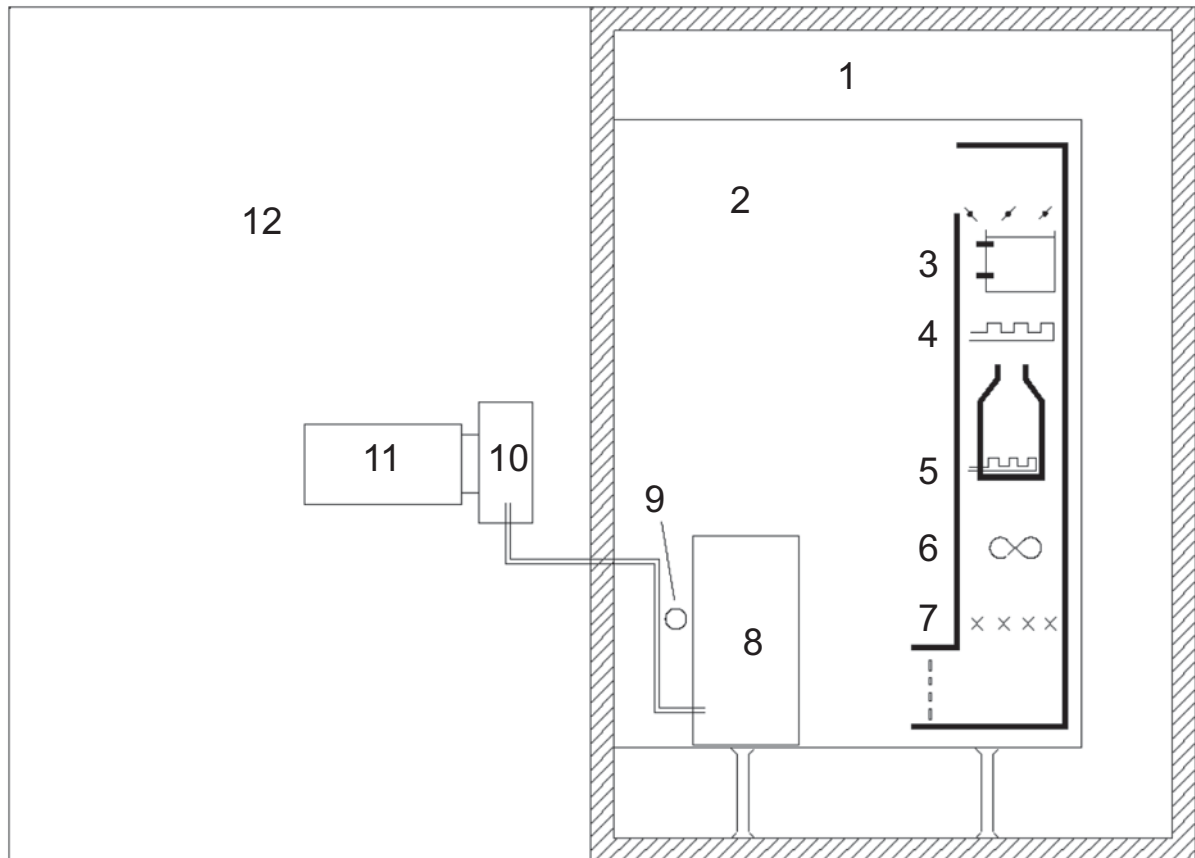

Key

- | | |
|------------------------------------|---------------------------------------|
| 1 controlled-temperature air space | 7 mixer |
| 2 outdoor-side compartment | 8 equipment under test – outdoor unit |
| 3 cooling coil | 9 air-sampling tube |
| 4 heating coil | 10 equipment under test – indoor unit |
| 5 humidifier | 11 airflow measuring apparatus |
| 6 fan | 12 indoor-side compartment |

Figure M.1 — Outdoor calorimeter test method arrangement

Annex N (informative)

Balanced-type calorimeter confirmative test method

N.1 General

N.1.1 This annex provides a test method for manufacturers to confirm the test results when the cooling and heating capacities are determined by the indoor air enthalpy test method.

This test method should not be used as a confirmative method by testing laboratories because it does not provide for simultaneous confirmative test results.

N.1.2 This method should be carried out by installing the equipment, which has been measured by the balanced-type calorimeter, in the indoor air enthalpy test apparatus for measurement under the same conditions as in the balanced-type calorimeter.

N.1.3 The performance of the indoor air enthalpy apparatus should be verified at least every 12 months using an industry standard cooling/heating calibrating device. A calibrating device may also be another piece of equipment for which the performance has been measured at an accredited national test laboratory as part of an industry-wide cooling/heating capacity verification programme.

N.2 Measurement

N.2.1 When this test method is employed, it is desirable to confirm that there is no difference between the capacities measured by the calorimeter and the indoor air enthalpy test apparatus. To accomplish this, the equipment should have thermocouples soldered to the return bends at approximately the midpoints of each of indoor and outdoor coil circuits. Equipment not sensitive to refrigerant charge may, alternatively, be provided with the pressure gauges connected to access valves or tapped into the suction and discharge lines.

N.2.2 Firstly, the equipment to be tested should be installed in the balanced-type calorimeter described in Annex D to carry out the measurement of the capacity. Then, the equipment should be moved to the indoor air enthalpy test apparatus and measured by the specified method. It is desirable to measure both cooling and heating capacities, though only one may be measured. However, if the cooling capacity is measured by the calorimeter, the same measurement should also be made in the indoor air-enthalpy test apparatus.

N.2.3 If no alteration is made to the installation of the equipment under test, a series of tests which are conducted subsequently should be deemed valid.

Annex O (informative)

Cooling condensate measurements

O.1 General

The latent cooling capacity should be determined from measurements of the condensate flow rate. The drain connection should be trapped to stabilize the condensate flow.

O.2 Calculations

O.2.1 The latent cooling capacity, ϕ_d , is calculated using Equation (O.1):

$$\phi_d = 1\,000K_{1q_{wc}} \quad (\text{O.1})$$

O.2.2 The sensible cooling capacity, ϕ_{sci} , is then calculated using Equation (O.2):

$$\phi_{sci} = \phi_{tci} - \phi_{ci} \quad (\text{O.2})$$

Annex P (normative)

Supplemental requirements when rating fan-less (coil only) type units

P.1 General

P.1.1 Except as noted in this annex, ducted equipment that does not include an indoor fan shall be tested and rated as specified in the normative sections of this International Standard.

NOTE Ducted equipment that does not include an indoor fan are also referred to as “coil-only” units.

P.1.2 Equipment that does not include an indoor fan when tested is typically combined with a hot-air furnace when installed in a building. The furnace's fan provides airflow across the indoor coil of the air-conditioner or heat pump.

P.2 Indoor coil installation: static pressure measurements

P.2.1 A short plenum shall be attached to both the inlet and outlet of the equipment. These plenums shall have cross-sectional dimensions equal to the dimensions of the equipment inlet and outlet, respectively. A static pressure tap shall be added at the centre of each side of each plenum, if rectangular, or at four evenly distributed locations along the circumference of oval or round plenums. For each plenum, the four static pressure taps shall be manifolded together. The minimum length of the plenums and the location of the static pressure taps relative to the equipment inlet and outlet shall be as shown in Figure P.1.

P.2.2 The static pressure taps described in P.2.1 shall be fabricated as described in C.4.1. A manometer (or equivalent instrument for measuring differential pressure) that is accurate to within $\pm 2,5$ Pa shall be used to measure the static pressure between the indoor coil air inlet and outlet. One side of this manometer shall be connected to the manifolded pressure taps installed in the outlet plenum. The other side of the manometer shall be connected to the manifolded pressure taps located in the inlet plenum.

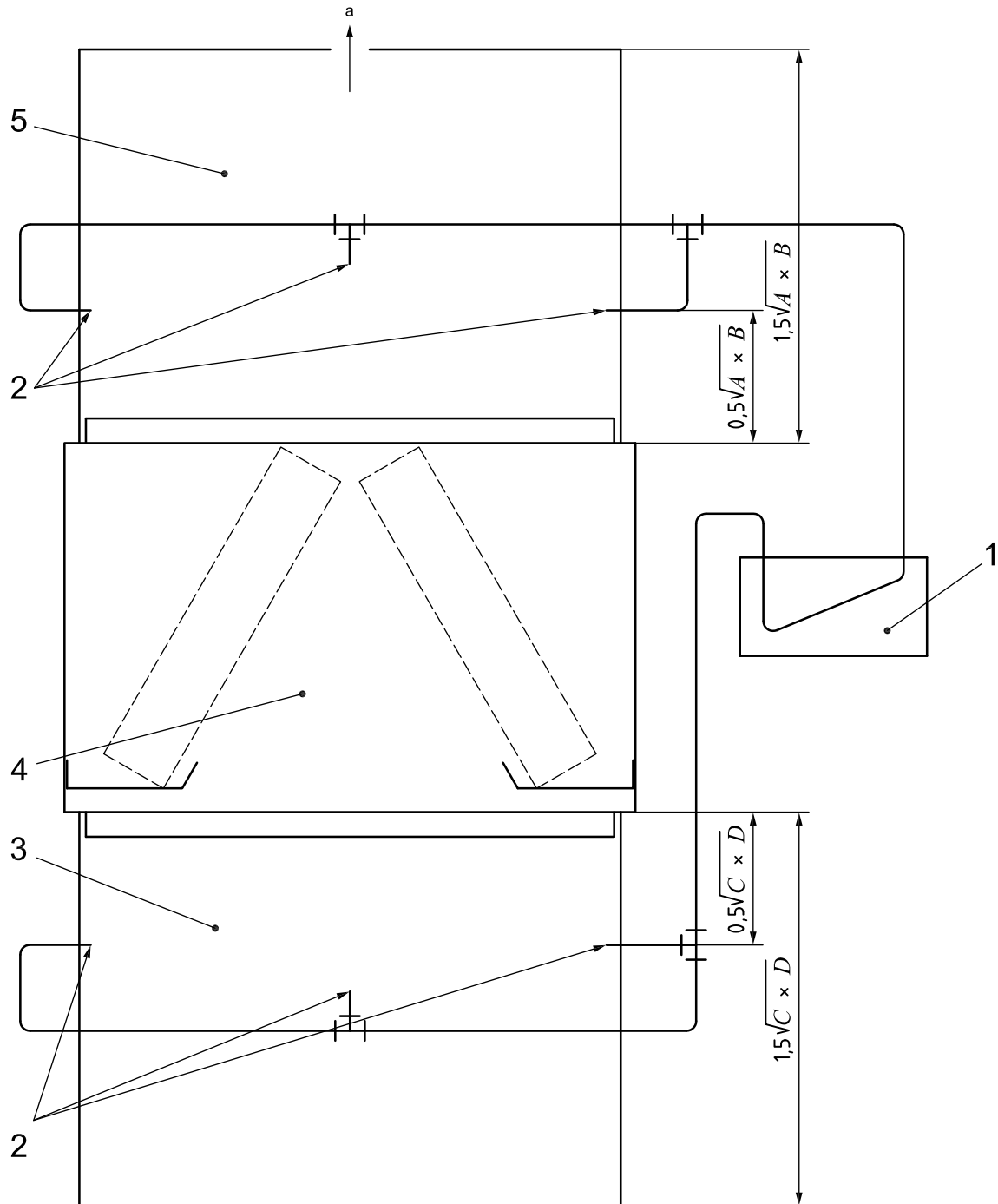

Key

- | | | | |
|---|----------------------|---|--------------|
| 1 | manometers | 4 | coil section |
| 2 | outlet pressure taps | 5 | outlet duct |
| 3 | inlet duct | | |

a To airflow measuring apparatus.

NOTE 1 A and B are outlet dimensions, C and D are inlet dimensions.

NOTE 2 For circular ducts, substitute $\frac{\pi D_i^2}{4}$ for $C \times D$ and $\frac{\pi D_o^2}{4}$ for $A \times B$.

NOTE 3 The length of the inlet duct, $1,5\sqrt{C \times D}$, is a minimum dimension. For more precise results, use $4\sqrt{C \times D}$.

Figure P.1 — Air static pressure drop measurement for a coil-only unit

P.3 Indoor-side air quantity

P.3.1 For equipment supplied without an indoor fan, the cooling capacity test shall be conducted at the air volume rate specified by the manufacturer, expressed in terms of standard air, or at a maximum pressure drop of 75 Pa across the indoor coil assembly, recommended enclosures and attachment means, whichever results in the lower air volume rate. This same air volume rate shall be used for all performance tests and for all heating capacity tests. If cooling capacity tests are conducted for more than one climatic condition (T1, T2, T3 in Table 2), then the highest of the cooling capacity air volume rates shall be used for all performance and heating capacity tests.

P.3.2 Airflow through the indoor coil shall be created by a separate fan. This fan shall be located downstream of the indoor coil, with the outlet static pressure taps shown in Figure P.1 and, if applicable, the instrumentation used to measure the dry-bulb temperature and water vapour content of the outlet air. If air volume rate is measured as described in Annex C, then the exhaust fan of the airflow measuring apparatus can be used to generate the airflow through the indoor coil.

P.4 Capacity adjustments

The measured cooling capacity shall be adjusted by deducting the estimated power required to circulate indoor air, determined as described in P.3, and the measured heating capacity shall be adjusted by adding the estimated power required to circulate indoor air.

The estimated fan power for equipment without indoor fan, P_{fan} , is calculated using Equation (P.1):

$$P_{fan} = \frac{q_V (P_e + P_c + 50)}{(\eta_{fan,i} \times \eta_{mot,i})} \quad (P.1)$$

where, $\eta_{fan,i}$, is estimated indoor fan static efficiency and is calculated using Equation (P.2):

$$\eta_{fan,i} = 0,1881 \times \ln(P_e + P_c + 50) - 0,47 \quad (P.2)$$

and $\eta_{mot,i}$ is the estimated indoor motor efficiency and is calculated using Equation (P.3):

$$\eta_{mot,i} = 0,06 \times \ln \left[q_V \left(\frac{P_e + P_c + 50}{\eta_{fan,i}} \right) \right] + 0,123 \quad (P.3)$$

Annex Q (informative)

Pictorial examples of the heating capacity test procedures given in 7.1

Q.1 General

The six schematic diagrams given in the examples in Q.2 show several of the cases which could occur while conducting a heating capacity test as specified in 7.1. All examples show cases where a defrost cycle ends the preconditioning period. Examples 2 to 6 in Q.2 represent cases where the indoor air enthalpy method is used and, as a result, the data collection period for the transient test lasts 3 h or three complete cycles (as opposed to 6 h or six complete cycles if using the calorimeter test method).

Q.2 Procedure flowchart for heating capacity test

The following flowchart gives the procedures to adopt and the clauses in the main text to use when conducting the heating capacity test.

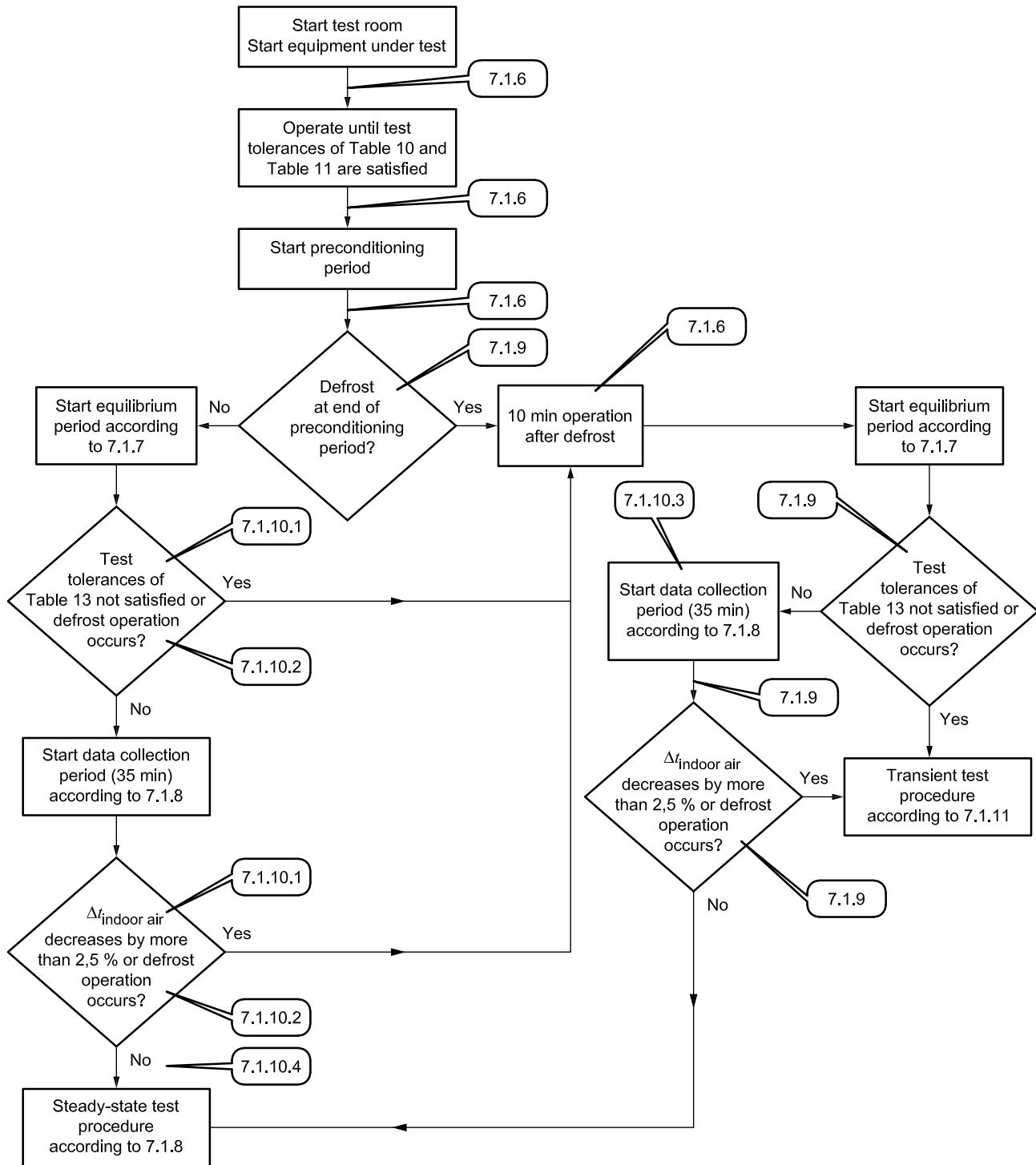
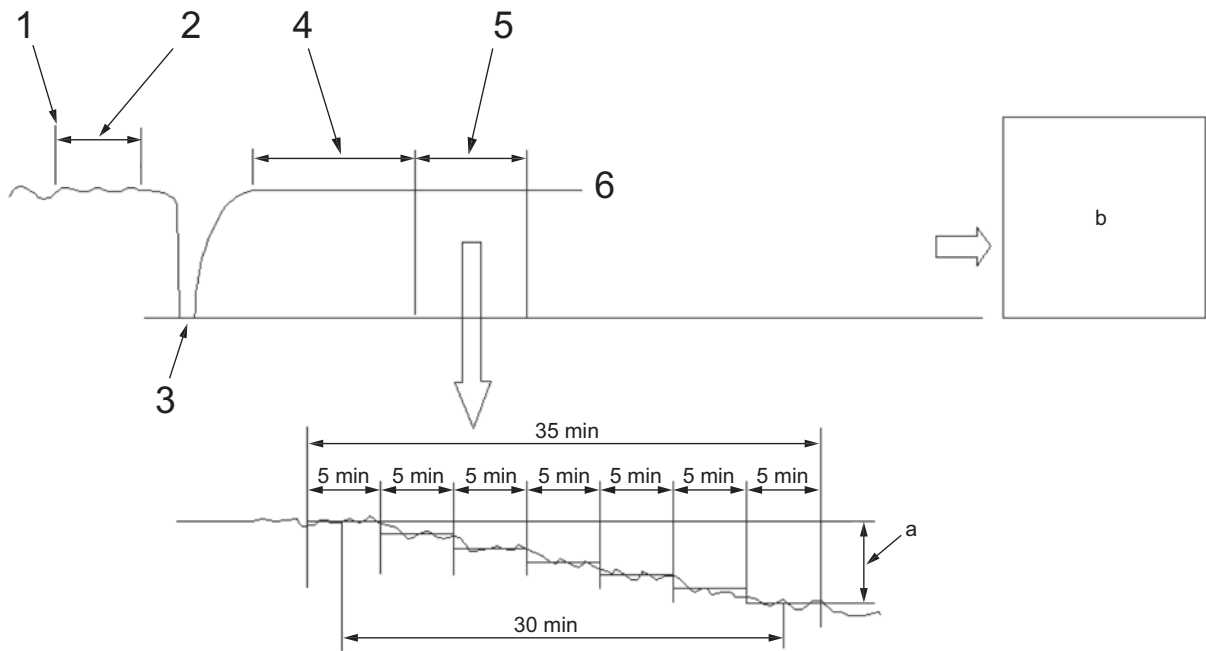

Figure Q.1 — Procedure flowchart

Example 1 Steady-state heating capacity test.



Key

- 1 compliance with test tolerances first achieved
- 2 preconditioning period (10 min minimum)
- 3 defrost at end of preconditioning period
- 4 equilibrium period (60 min)
- 5 data collection period (35 min)
- 6 inside air temperature difference, $\Delta t_{\text{indoor air}}$
- a $\Delta t_{\text{indoor air}}$ decreases by 2,5 % or less during the first 35 min of the data collection period.
- b Steady-state test: terminate test when data collection period equals 35 min.

Example 2 Transient heating capacity test with no defrost cycles.

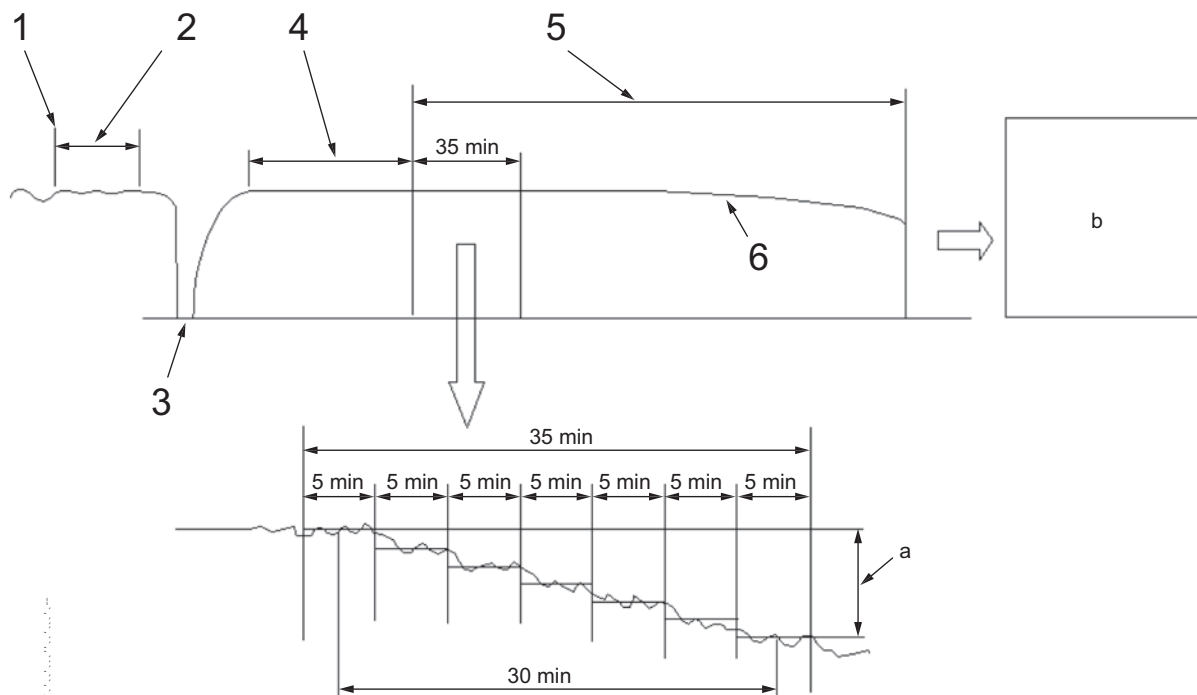

Key

- 1 compliance with test tolerances first achieved
- 2 preconditioning period (10 min minimum)
- 3 defrost at end of preconditioning period
- 4 equilibrium period (60 min)
- 5 data collection period (3 h)
- 6 inside air temperature difference, $\Delta t_{\text{indoor air}}$
- a $\Delta t_{\text{indoor air}}$ decreases by more than 2,5 % during the first 35 min of the data collection period.
- b Transient test: terminate test when data collection period equals 3 h.

Example 3 Transient heating capacity test with one defrost cycle during the data collection period.

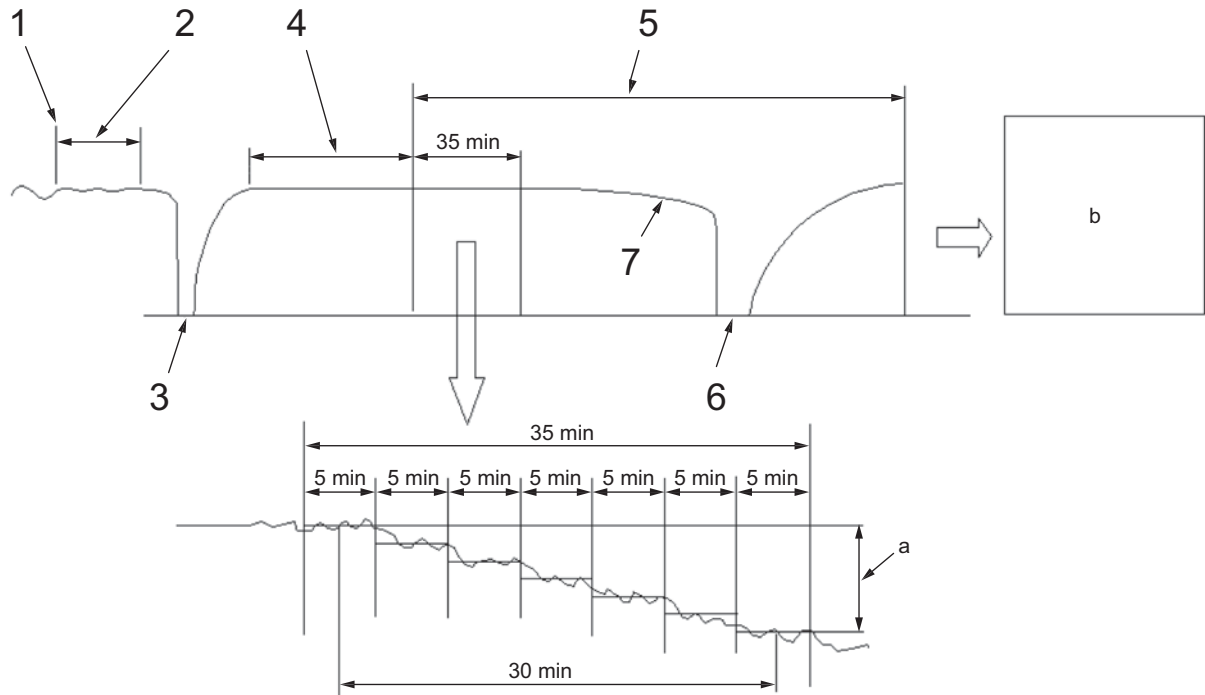

Key

- 1 compliance with test tolerances first achieved
- 2 preconditioning period (10 min minimum)
- 3 defrost at end of preconditioning period
- 4 equilibrium period (60 min)
- 5 data collection period (3 h)
- 6 automatic defrost cycle occurs
- 7 inside air temperature difference, $\Delta t_{\text{indoor air}}$
- a $\Delta t_{\text{indoor air}}$ decreases by more than 2,5 % during the first 35 min of the data collection period.
- b Transient test: terminate test when data collection period equals 3 h.

Example 4 Transient heating capacity test with one complete cycle during the data collection period.

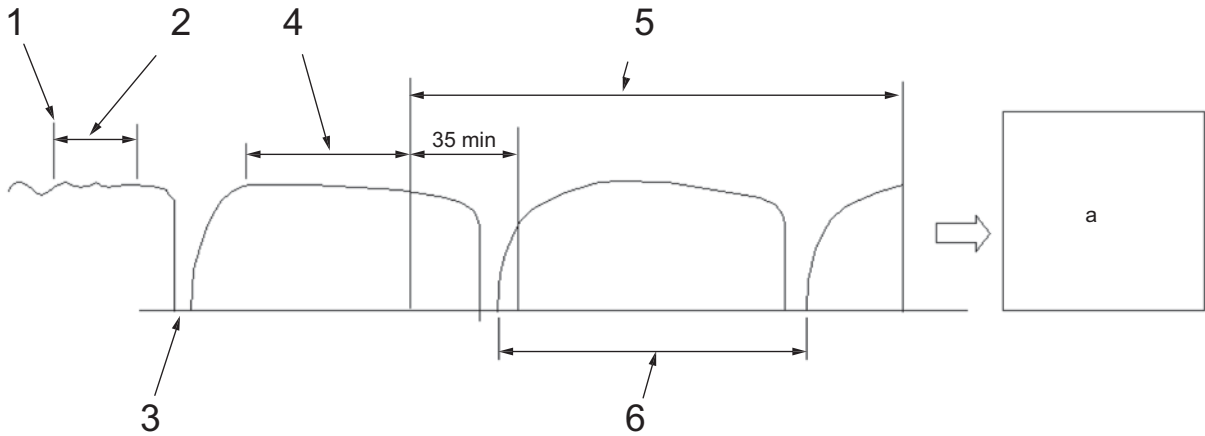

Key

- 1 compliance with test tolerances first achieved
- 2 preconditioning period (10 min minimum)
- 3 defrost at end of preconditioning period
- 4 equilibrium period (60 min)
- 5 data collection period (3 h)
- 6 one complete defrost cycle
- a Transient test: terminate test when data collection period equals 3 h.

Example 5 Transient heating capacity test with two complete cycles during the data collection period.

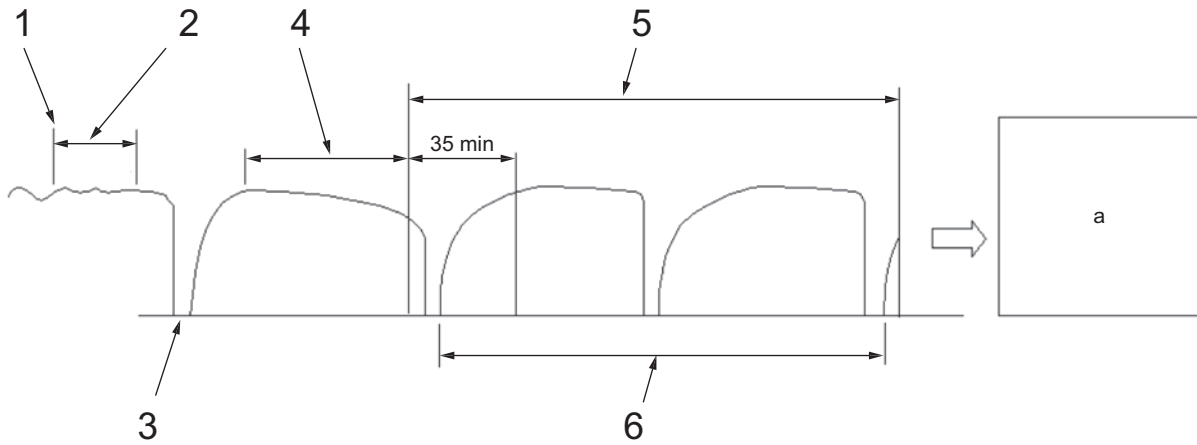

Key

- 1 compliance with test tolerances first achieved
- 2 preconditioning period (10 min minimum)
- 3 defrost at end of preconditioning period
- 4 equilibrium period (60 min)
- 5 data collection period (3 h)
- 6 two complete defrost cycles
- a Transient test: terminate test when data collection period equals 3 h.

Example 6 Transient heating capacity test with three complete cycles during the data collection period.

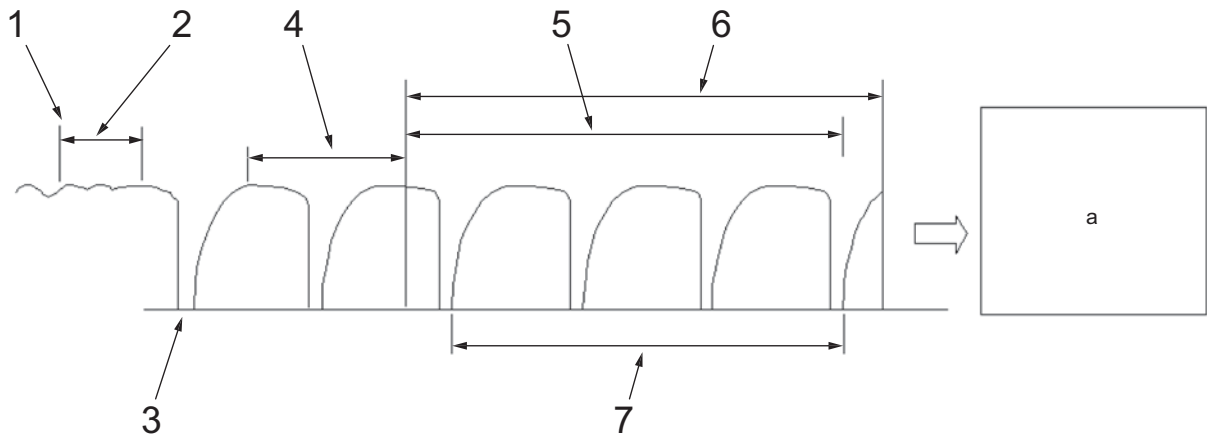

Key

- 1 compliance with test tolerances first achieved
- 2 preconditioning period (10 min minimum)
- 3 defrost at end of preconditioning period
- 4 equilibrium period (60 min)
- 5 data collection period
- 6 three hours
- 7 three complete defrost cycles
- a Transient test: terminate test at the end of three complete cycles within the data collection period.

Bibliography

- [1] ISO 917, *Testing of refrigerant compressors*
- [2] ISO 3966, *Measurement of fluid flow in closed conduits — Velocity area method using Pitot static tubes*
- [3] ISO 5151, *Non-ducted air-conditioners and heat pumps — Testing and rating for performance*
- [4] ISO 5167-1, *Measurement of fluid flow by means of pressure differential devices inserted in circular cross-section conduits running full — Part 1: General principles and requirements*
- [5] ISO/IEC Guide 98-3, *Uncertainty of measurement — Part 3: Guide to the expression of uncertainty in measurement (GUM:1995)*

.....

ICS 23.120; 27.080

Price based on 94 pages