**Health and safety in welding and allied
processes — Equipment for capture
and separation of welding fume —**

**Part 1:
Requirements for testing and marking
of separation efficiency**

*Hygiène et sécurité en soudage et techniques connexes —
Équipements de captage et de filtration des fumées de soudage —*

*Partie 1: Exigences pour les essais et marquage relatifs à l'efficacité
de la séparation*





COPYRIGHT PROTECTED DOCUMENT

© ISO 2013

All rights reserved. Unless otherwise specified, no part of this publication may be reproduced or utilized otherwise in any form or by any means, electronic or mechanical, including photocopying, or posting on the internet or an intranet, without prior written permission. Permission can be requested from either ISO at the address below or ISO's member body in the country of the requester.

ISO copyright office
Case postale 56 • CH-1211 Geneva 20
Tel. + 41 22 749 01 11
Fax + 41 22 749 09 47
E-mail copyright@iso.org
Web www.iso.org

Published in Switzerland

Contents

	Page
Foreword	iv
Introduction	v
1 Scope	1
2 Normative references	1
3 Terms and definitions	1
4 Requirement	2
5 Principle	2
6 Equipment	2
7 Test method	5
7.1 Selection of test arrangement.....	5
7.2 Test conditions.....	5
7.3 Procedure.....	5
7.4 Calculation of the separation efficiency.....	9
8 Accuracy of measurement	9
9 Marking	9
Annex A (normative) Label for welding fume separation equipment	10
Annex B (informative) Welding fume source	11
Annex C (informative) Test cabin	13
Bibliography	14

Foreword

ISO (the International Organization for Standardization) is a worldwide federation of national standards bodies (ISO member bodies). The work of preparing International Standards is normally carried out through ISO technical committees. Each member body interested in a subject for which a technical committee has been established has the right to be represented on that committee. International organizations, governmental and non-governmental, in liaison with ISO, also take part in the work. ISO collaborates closely with the International Electrotechnical Commission (IEC) on all matters of electrotechnical standardization.

International Standards are drafted in accordance with the rules given in the ISO/IEC Directives, Part 2.

The main task of technical committees is to prepare International Standards. Draft International Standards adopted by the technical committees are circulated to the member bodies for voting. Publication as an International Standard requires approval by at least 75 % of the member bodies casting a vote.

Attention is drawn to the possibility that some of the elements of this document may be the subject of patent rights. ISO shall not be held responsible for identifying any or all such patent rights.

ISO 15012-1 was prepared by the European Committee for Standardization (CEN), in collaboration with ISO Technical Committee TC 44, *Welding and allied processes*, Subcommittee SC 9, , in accordance with the Agreement on technical cooperation between ISO and CEN (Vienna Agreement).

This second edition cancels and replaces the first edition (ISO 15012-1:2004), which has been technically revised.

ISO 15012 consists of the following parts, under the general title *Health and safety in welding and allied processes — Equipment for capture and separation of welding fume*:

- *Part 1: Requirements for and testing and marking of separation efficiency*
- *Part 2: Determination of the minimum air volume flow rate of captor hoods and nozzles*

The following part is under preparation:

- *Part 4: Design requirements*

Introduction

It is common practice in the fabrication industry to control exposure to welding fume using local exhaust ventilation equipment that, following capture and separation of the fume, returns the extracted air to the workplace or exhausts it to the atmosphere. It is important that such equipment has high separation efficiency so that as little fume as possible is recirculated or exhausted. This part of ISO 15012 has therefore been promulgated to specify requirements and a test method for determining the efficiency of welding fume separation equipment.

Health and safety in welding and allied processes — Equipment for capture and separation of welding fume —

Part 1: Requirements for testing and marking of separation efficiency

1 Scope

This part of ISO 15012 specifies a method for testing equipment for the separation of welding fume in order to determine whether its separation efficiency meets specified requirements.

The method specified does not apply to testing of filter cartridges independent of the equipment in which they are intended to be used.

This part of ISO 15012 applies to equipment that is manufactured after its publication.

2 Normative references

The following referenced documents are indispensable for the application of this document. For dated references, only the edition cited applies. For undated references, the latest edition of the referenced document (including any amendments) applies.

ISO 2602, *Statistical interpretation of test results — Estimation of the mean — Confidence interval*

ISO 15011-1, *Health and safety in welding and allied processes — Laboratory method for sampling fume and gases — Part 1: Determination of fume emission rate during arc welding and collection of fume for analysis*

3 Terms and definitions

For the purposes of this document, the following terms and definitions apply.

3.1

local exhaust ventilation

LEV

use of extraction to remove contaminated air at or near to its source

3.2

welding fume separation equipment

air filtration equipment, the purpose of which is to separate particles generated by welding and allied processes from workplace air

3.3

filter cleaning system

system designed to clean the filter of welding fume separation equipment in order to restore the air flow rate through the filter when it is reduced by an accumulation of welding fume particles

3.4

separation efficiency by mass

ratio of the mass of particles retained by welding fume separation equipment to the mass of particles entering the equipment during a given period

Note 1 to entry: See also EN 1093-6^[10] and EN 1093-7^[11]

3.5

emission rate

mass of the particles emitted by the welding fume source per time

Note 1 to entry: Emission rate is expressed in milligrams per second.

Note 2 to entry: See [Annex B](#).

3.6

free-standing unit

separation equipment with an integrated fan

3.7

modular system

separation equipment consisting of a filter box, or multiple filter boxes, connected to a single fan

4 Requirement

When tested in accordance with the procedure described in [Clause 7](#), welding fume separation equipment shall have a lower confidence limit value of separation efficiency ≥ 99 %.

5 Principle

The method is based on the methods specified in EN 1093-6^[10] and EN 1093-7^[11] The welding fume separation equipment under test is operated under defined conditions, according to its intended use.

The emission rate of a welding fume source is measured and used subsequently to calculate the concentration of fume generated during a test period when separation efficiency is measured.

Before separation efficiency measurements are made, welding fume is generated using the welding fume source and separated for a period of 30 min.

For equipment with filters that are not intended to be cleaned, the concentration of fume passing through the separation equipment during a 30 min period is measured and used together with the fume concentration calculated from the fume emission rate to determine the separation efficiency.

For equipment with cleanable filters, an additional separation efficiency measurement is performed after a further welding period without measurement and filter cleaning. The average of the two separation efficiencies is calculated.

Two tests are performed and the average, the 95 % one-sided confidence interval and the lower confidence limit value of the separation efficiency are calculated according to ISO 2602. If the resulting lower confidence limit value is less than the required separation efficiency, consideration shall be given to performing further tests.

6 Equipment

6.1 Welding fume source, capable of maintaining an emission rate of $10 \text{ mg/s} \pm 2 \text{ mg/s}$ throughout the test period. The welding fume source shall be fitted with an extracted fume hood that retains all the fume emitted and shall be designed in such a way that it can be connected to the inlet duct of the test cabin, as described in [Figure 1](#), or directly to welding fume separation equipment with a ducted outlet, as described

in [Figure 2](#). It shall be possible to determine the welding fume emission rate *in situ* without disturbing the welding set-up in any way. An example of a suitable welding source and parameters required to achieve the required welding fume emission rate are described in [Annex B](#).

6.2 Test cabin, consisting of an enclosure for the welding fume separation equipment under test, connected to the welding fume source via an upstream measurement duct. The cabin is connected to a downstream measurement duct and an air mover (see [Figure 1](#)). The air flow rate through the air mover is adjusted to between 95 % and 100 % of the air flow rate in the upstream duct, thus ensuring a small positive air pressure in the cabin.

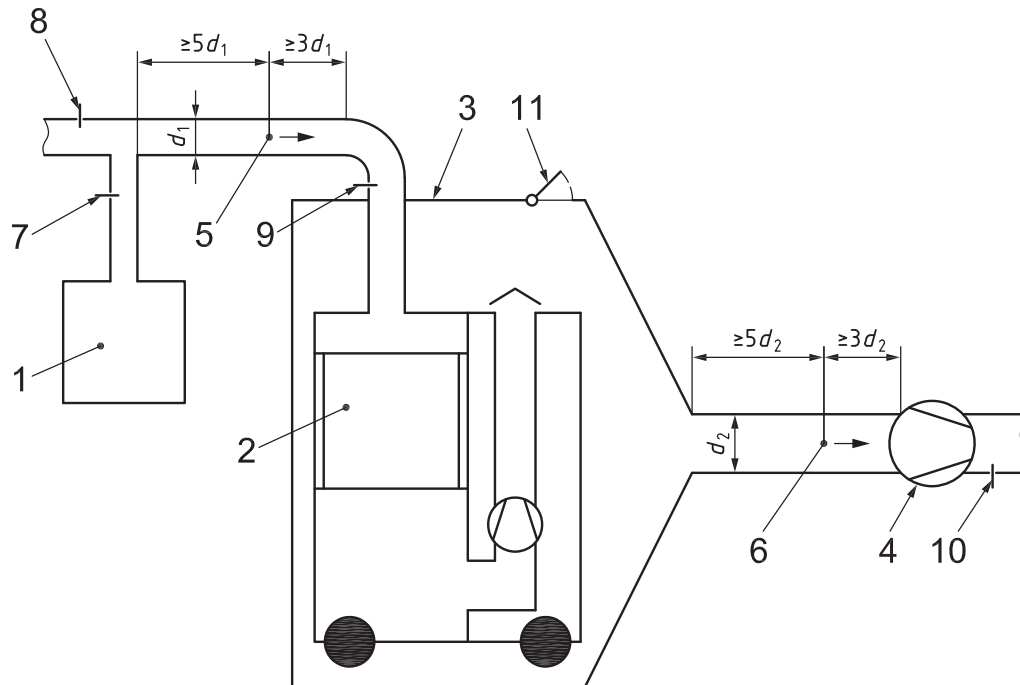

Key

- 1 welding fume source (see [Figure B.1](#))
- 2 welding fume separation equipment
- 3 test cabin with funnel shaped outlet
- 4 air mover
- 5 position for measuring the air flow rate in the upstream duct, $q_{V,1}$
- 6 positions for measuring the air flow rate in the downstream duct, $q_{V,2}$ and isokinetic sampling of welding fume in the downstream duct
- 7 damper (to control the air flow rate passing through the welding fume source in order to avoid shielding gas disturbance)
- 8 damper (to ensure that all welding fume is captured, even when filter units with a low air flow rate are under test)
- 9 damper (to regulate the total air flow rate passing through the separation equipment)
- 10 damper (to control the air flow rate in the downstream duct in order to achieve a slight overpressure in the cabin)
- 11 gap with a flap (to prevent damage on the cabin in case of high overpressure)
- d_1 upstream duct diameter
- d_2 downstream duct diameter

Figure 1 — Example of test cabin (schematic layout)

The positions for measuring the air flow rate and isokinetic sampling of welding fume in the downstream duct are not the same, but are shown thus in [Figure 1](#) for convenience. The requirement is that they comply with the dimensions marked in [Figure 1](#).

6.3 Test arrangement for welding fume separation equipment with a ducted outlet, consisting of a welding fume source connected to the equipment via an upstream measurement duct. The outlet of the welding fume separation equipment is directly linked to the downstream measurement duct (see [Figure 2](#)).

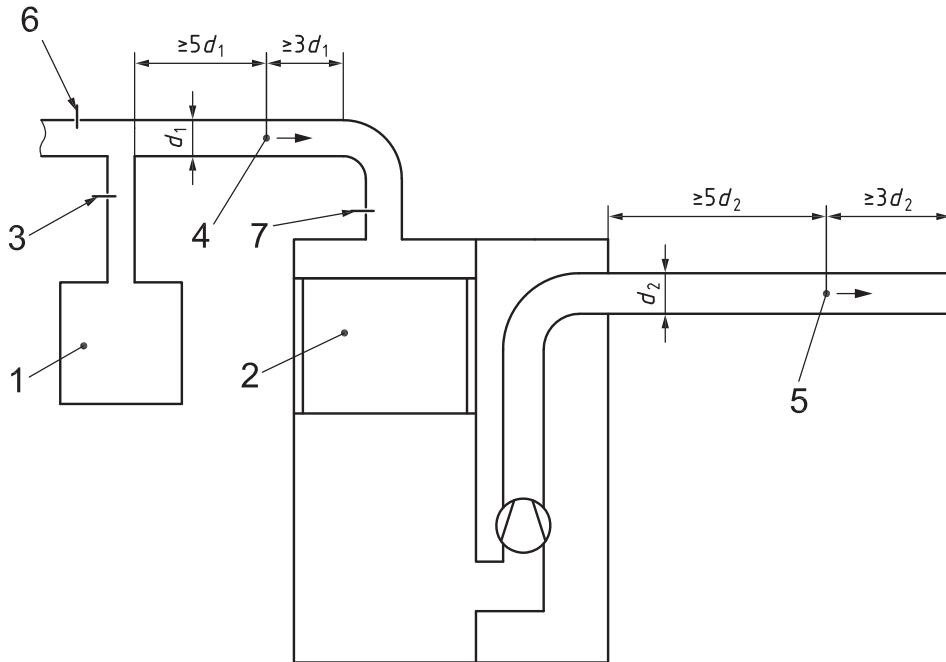

Key

- 1 welding fume source
- 2 welding fume separation equipment
- 3 damper (to control the air flow passing through the welding fume source in order to avoid shielding gas disturbance)
- 4 position of equipment for measuring the air flow rate in the upstream duct
- 5 position of equipment for measuring the air flow rate and the welding fume concentration in the downstream duct
- 6 damper (to ensure that all welding fume is captured, even when filter units with low air flow rates are under test)
- 7 damper (to regulate the total air flow passing through the separation equipment)
- d_1 upstream duct diameter
- d_2 downstream duct diameter

Figure 2 — Test arrangement for welding fume separation equipment with a ducted outlet (schematic layout)

6.4 Air volume flow rate measurement equipment, capable of measuring rates up to 2 000 m³/h continuously, to within ± 200 m³/h or better. The following combination of equipment is suitable.

A flow meter with a calibrated relationship between pressure difference and air flow rate, e.g. an orifice plate, together with a digital manometer with a reading accuracy of at least 0,1 Pa to measure the pressure difference across it. The digital manometer shall have a logging capability or be connected to a logging system with a logging frequency of 1 min or less.

A device for measuring air flow rate with equivalent performance is also suitable.

The calibration of all equipment shall be traceable to national standards.

7 Test method

7.1 Selection of test arrangement

Use the test cabin illustrated in [Figure 1](#) or the test arrangement shown in [Figure 2](#). Any welding fume separation equipment (including individual modules of a modular system) can be tested using the test cabin depicted in [Figure 1](#), provided it can be fitted into the test cabin. Only welding fume separation equipment with a ducted outlet can be tested using the arrangement shown in [Figure 2](#).

7.2 Test conditions

Carry out the test under conditions that are similar to the normal working conditions for the equipment under test.

For modular welding fume separation equipment, if the designed air volume flow rate is greater than 2000 m³/h, carry out the test of separation efficiency using a specially made scaled down typical module. If different fans can be used in combination with the welding fume separation equipment, carry out the test of separation efficiency using the minimum and maximum air volume flow rates recommended by the manufacturer.

7.3 Procedure

7.3.1 Source emission rate measurement

Determine the emission rate of the welding source using the exact conditions used during testing and the general approach specified in ISO 15011-1. Weld while sampling total welding fume emission on a preweighed filter. Stop welding and sampling and reweigh the filter. Calculate the emission rate by dividing the mass of welding fume collected on the filter by the sampling time.

7.3.2 Equipment without filter cleaning system

Select the test arrangement and set up the test conditions.

- Determine the source emission rate according to [7.3.1](#).
- Switch on the welding fume separation equipment, the air volume flow rate measurement systems and the air mover in the downstream measurement duct. Adjust the flow rate in the upstream duct using the dampers to the air volume flow rate stated by the manufacturer.
- Monitor the air volume flow rate throughout the test. If at any point the air volume flow rate falls below the minimum value specified by the manufacturer, discontinue the test. Report that the test could not be completed under the specified conditions while meeting the manufacturer's specification for minimum air volume flow rate.
- Generate and separate welding fume for an arcing period of 30 min without measurement in order to precondition the separation equipment. Use precoated filters to test equipment with mechanical separation systems, if their use is intended by the manufacturer.
- Commence sampling and collect samples of welding fume for an arcing period of 30 min.
- Continue welding for a further arcing period of 60 min without measurement (see [Figure 3](#)) and record the air volume flow rate at the end.
- When the test is completed, repeat the determination of the source emission rate according to [7.3.1](#) and average the results of the first and second emission rate determinations.

Welding fume separation equipment - Type:

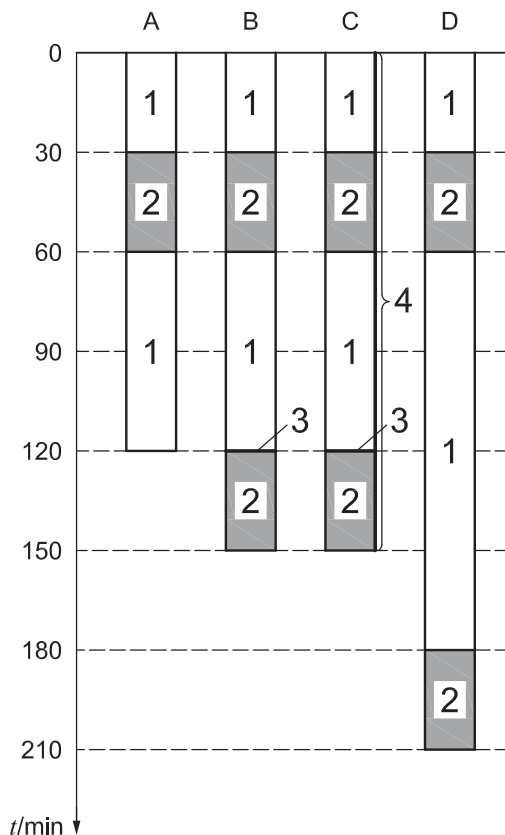

Key

Type:

- A welding fume separation equipment without filter cleaning system
- B welding fume separation equipment with manually initiated filter cleaning system
- C welding fume separation equipment with an automatically initiated filter cleaning system
- D welding fume separation equipment with electrostatic precipitator

t arcing time

- 1 welding without efficiency measurement
- 2 welding with efficiency measurement
- 3 manually initiated cleaning
- 4 automatically initiated filter cleaning system is active

NOTE The test is not invalidated if automatically initiated cleaning of the filter occurs at any point during the test.

Figure 3 — Test procedure

- Repeat the welding fume separation test after fitting a new filter in the welding fume separation equipment.
- Determine the separation efficiency by mass for each test using Formula (1).
- Calculate the average, the 95 % one-sided confidence interval and the lower confidence limit value of the separation efficiency based on the test results and compare to the specified requirements.

NOTE ISO 15767[6] specifies measures to be taken to control and characterize errors in weighing collected aerosols.

7.3.3 Equipment with manually initiated cleaning system

Select the test arrangement and set up the test conditions.

- Determine the source emission rate according to [7.3.1](#).
- Switch on the welding fume separation equipment, the air volume flow rate measurement systems, and the air mover in the downstream measurement duct. Adjust the flow rate in the upstream duct using the dampers to the air volume flow rate stated by the manufacturer.
- Monitor the air volume flow rate throughout the test. If at any point the air volume flow rate falls below the minimum value specified by the manufacturer, discontinue the test. Report that the test could not be completed under the specified conditions while meeting the manufacturer's specification for minimum air volume flow rate.
- Generate and separate welding fume for an arcing period of 30 min without measurement in order to precondition the separation equipment. Use precoated filters to test equipment with mechanical separation systems, if their use is intended by the manufacturer.
- Commence sampling and collect samples of welding fume for an arcing period of 30 min.
- Continue welding for a further arcing period of 60 min without measurement (see [Figure 3](#)) providing the air flow rate exceeds the minimum value specified by the manufacturer.
- Initiate a filter cleaning and continue welding for a period of 30 min with measurement and with new sampling filters.
- When the test is completed, repeat the determination of the source emission rate according to [7.3.1](#) and average the results of the first and second emission rate determinations.
- Calculate the separation efficiency for each of the measurement periods and calculate the average. This is the result of the test.
- Repeat the welding fume separation test after fitting a new filter in the welding fume separation equipment.
- Calculate the average, the 95 % one-sided confidence interval and the lower confidence limit value of the separation efficiency based on the test results and compare to the specified requirements.

NOTE ISO 15767[6] specifies measures to be taken to control and characterize errors in weighing collected aerosols.

7.3.4 Equipment with automatically initiated cleaning system

Select the test arrangement and set up the test conditions.

- Determine the source emission rate according to [7.3.1](#).
- Switch on the welding fume separation equipment, the air volume flow rate measurement systems, and the air mover in the downstream measurement duct. Adjust the flow rate in the upstream duct using the dampers to the air volume flow rate stated by the manufacturer.
- Monitor the air volume flow rate throughout the test. If at any point the air volume flow rate falls below the minimum value specified by the manufacturer, discontinue the test. Report that the test could not be completed under the specified conditions while meeting the manufacturer's specification for minimum air volume flow rate.

- Generate and separate welding fume for an arcing period of 30 min without measurement in order to precondition the separation equipment. Use precoated filters to test equipment with mechanical separation systems, if their use is intended by the manufacturer.
- Commence sampling and collect samples of welding fume for an arcing period of 30 min.
- Continue welding for a further arcing period of 60 min without measuring (see [Figure 3](#)) providing the air flow rate exceeds the minimum value specified by the manufacturer.
- Initiate a filter cleaning and continue welding for an arcing period of 30 min with measurement and with new sampling filters.

NOTE 1 Any automatically initiated cleaning cycles occurring during the test can be ignored.

- When the test is completed, repeat the determination of the source emission rate according to [7.3.1](#) and average the results of the first and second emission rate determinations.
- Calculate the separation efficiency for each of the measurement periods and calculate the average. This is the result of the test.
- Repeat the welding fume separation test after fitting a new filter in the welding fume separation equipment.
- Calculate the average, the 95 % one-sided confidence interval and the lower confidence limit value of the separation efficiency based on the test results and compare to the specified requirements.

NOTE 2 ISO 15767^[6] specifies measures to be taken to control and characterize errors in weighing collected aerosols.

7.3.5 Equipment with electrostatic precipitators

Select the test arrangement and set up the test conditions.

- Determine the source emission rate according to [7.3.1](#).
- Switch on the welding fume separation equipment, the air volume flow rate measurement systems, and the air mover in the downstream measurement duct. Adjust the flow rate in the upstream duct using the dampers to the air volume flow rate stated by the manufacturer.
- Monitor the air volume flow rate throughout the test. If at any point the air volume flow rate falls below the minimum value specified by the manufacturer, discontinue the test. Report that the test could not be completed under the specified conditions while meeting the manufacturer's specification for minimum air volume flow rate.
- Generate and separate welding fume for an arcing period of 30 min without measurement in order to precondition the separation equipment.
- Commence sampling and collect samples of welding fume for an arcing period of 30 min.
- Continue welding for a further arcing period of 120 min without measurement (see [Figure 3](#)) providing the air flow rate exceeds the minimum value specified by the manufacturer.
- Repeat the measurement of the separation efficiency.
- When the test is completed, repeat the determination of the source emission rate according to [7.3.1](#) and average the results of the first and second emission rate determinations.
- Calculate the separation efficiency for each of the measurement periods and calculate the average. This is the result of the test.
- Repeat the welding fume separation test after fitting a new filter in the welding fume separation equipment.

- Calculate the average, the 95 % one-sided confidence interval and the lower confidence limit value of the separation efficiency based on the test results and compare to the specified requirements.

NOTE ISO 15767[6] specifies measures to be taken to control and characterize errors in weighing collected aerosols.

7.4 Calculation of the separation efficiency

Calculate the separation efficiency by mass η using Formula (1):

$$\eta = \left(1 - \frac{\gamma_{\text{out}}}{\gamma_{\text{in}}} \right) \times 100 \% \quad (1)$$

where

$$\gamma_{\text{out}} = \frac{m_{\text{s out}}}{V_{\text{s out}}} \text{ mg/m}^3 \quad (2)$$

$$\gamma_{\text{in}} = \frac{m_{\text{in}}}{V_{\text{in}}} \text{ mg/m}^3 \quad (3)$$

in which

$m_{\text{s out}}$ is the mass of the welding fume particles on the sampling filter in the downstream air [mg];

m_{in} is total mass of emitted welding fume from the source calculated from the average emission rate multiplied by the measuring time [mg];

$V_{\text{s out}}$ is the total air volume that passes through the sampling filter in the downstream air [m³];

V_{in} is the total air volume that passes through the separation equipment during the test [m³].

Use the method described in ISO 2602 for statistical interpretation of the test results.

8 Accuracy of measurement

The measurement error is expected not to exceed 1 %, based on a worst case scenario.

9 Marking

If the requirement of [Clause 4](#) is met, the manufacturer may label the equipment W3 as shown in [Annex A](#).

NOTE In ISO 15012-1:2004, equipment with a separation efficiency >95 % was labelled W1 and equipment with a separation efficiency >98 % was labelled W2.

Annex A (normative)

Label for welding fume separation equipment

See Figure A.1.

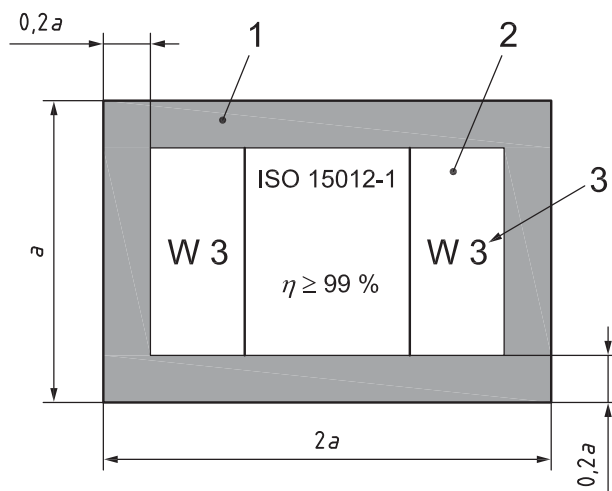

Key

- 1 RAL 5005 (blue)
- 2 RAL 9003 (white)
- 3 RAL 9004 (black)
- a 50 mm or 100 mm
- η separation efficiency by mass

NOTE Marking with W3 is optional.

Figure A.1 — Label for welding fume separation equipment

Annex B (informative)

Welding fume source

A suitable welding fume source consists of a continuous wire welding torch, connected to a power source operating with pulsed parameters, welding on a rotating steel drum, as shown schematically in [Figure B.1](#). The rig is set up to enable welding to progress continuously for the duration of the test period by fixing the position of the welding torch while automatically shifting the steel drum horizontally along its axis by at least the width of a weld with each rotation of the drum.

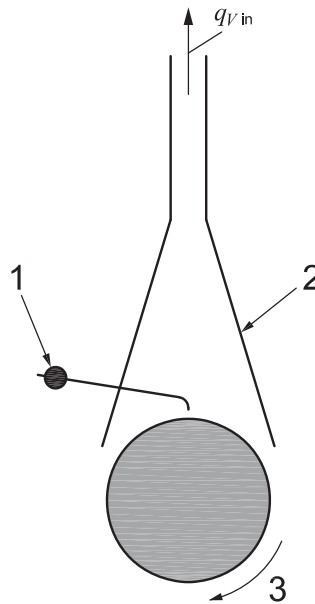

Key

- | | |
|-----------|--------------------------------------|
| 1 | continuous wire welding torch |
| 2 | fume hood |
| 3 | rotating steel drum |
| qV_{in} | air volume flow rate from the source |

Figure B.1 — Welding fume source (schematic layout)

The welding conditions in [Table B.1](#) are suitable for obtaining an emission rate of approximately 10 mg/s.

Table B.1 — Example of welding conditions for an emission rate of 10 mg/s

Parameter	Condition
Welding process	Metal active gas (MAG) welding
Material of the welding wire	EN 440 G3 Si1
Diameter of the welding wire	1,2 mm
Wire feed speed	6,3 m/min
Welding voltage	34 V
Peak current	370 A
Basic current	45 A
Peak time	4,2 ms
Peak frequency	200 Hz
Shielding gas	82 % Ar, 18 % CO ₂
Shielding gas flow rate	17 l/min
Contact tip to work piece distance	18 mm to 20 mm
Diameter of the drum	600 mm
Welding speed	8 mm/s

Annex C **(informative)**

Test cabin

A suitable test cabin for a test arrangement described in [Figure 1](#) is a housing enclosing completely the welding fume separation equipment under test. The cabin shall be provided with openings for connecting the device to the welding fume source and to the measurement duct. The dimensions of the cabin should be matched to the welding fume separation device under test in a suitable manner. For testing of free-standing units with a maximum air volume flow rate $q_{V \max}$ approximately 1 500 m³/h, a test cabin with dimensions of 2,2 m × 1,5 m × 2,2 m (length by width by height) has proven to be suitable.

Bibliography

- [1] ISO 5167 (all parts), *Measurement of fluid flow by means of pressure differential devices inserted in circular cross-section conduits running full*
- [2] ISO 5801, *Fans — Performance testing using standardized airways*
- [3] ISO 7731, *Ergonomics — Danger signals for public and work areas — Auditory danger signals*
- [4] ISO 12100:2010, *Safety of machinery — General principles for design — Risk assessment and risk reduction*
- [5] ISO 14341, *Welding consumables — Wire electrodes and weld deposits for gas shielded metal arc welding of non alloy and fine grain steels — Classification*
- [6] ISO 15767, *Workplace atmospheres — Controlling and characterizing uncertainty in weighing collected aerosols*
- [7] EN 842, *Safety of machinery — Visual danger signals — General requirements, design and testing*
- [8] EN 1093-1, *Safety of machinery — Evaluation of the emission of airborne hazardous substances — Part 1: Selection of test methods*
- [9] EN 1093-3, *Safety of machinery — Evaluation of the emission of airborne hazardous substances — Part 3: Test bench method for the measurement of the emission rate of a given pollutant*
- [10] EN 1093-6, *Safety of machinery — Evaluation of the emission of airborne hazardous substances — Part 6: Separation efficiency by mass, unducted outlet*
- [11] EN 1093-7, *Safety of machinery — Evaluation of the emission of airborne hazardous substances — Part 7: Separation efficiency by mass, ducted outlet*

