**Road vehicles — Measurement of
driver visual behaviour with respect
to transport information and control
systems —**

**Part 1:
Definitions and parameters**

*Véhicules routiers — Mesurage du comportement visuel du
conducteur en relation avec les systèmes de commande et
d'information du transport —*

Partie 1: Définitions et paramètres





COPYRIGHT PROTECTED DOCUMENT

© ISO 2014

All rights reserved. Unless otherwise specified, no part of this publication may be reproduced or utilized otherwise in any form or by any means, electronic or mechanical, including photocopying, or posting on the internet or an intranet, without prior written permission. Permission can be requested from either ISO at the address below or ISO's member body in the country of the requester.

ISO copyright office
Case postale 56 • CH-1211 Geneva 20
Tel. + 41 22 749 01 11
Fax + 41 22 749 09 47
E-mail copyright@iso.org
Web www.iso.org

Published in Switzerland

Contents

	Page
Foreword	iv
Introduction	v
1 Scope	1
2 Normative references	1
3 Terms and definitions	1
4 Definition of measures and metrics	4
4.1 Basic Direct Measures	5
4.2 Glance Metrics Derived From Basic Measures	5
5 Data collection and analysis	7
6 Data presentation	7
Annex A (informative) Supporting Figures to explain terms and definitions	9
Bibliography	13

Foreword

ISO (the International Organization for Standardization) is a worldwide federation of national standards bodies (ISO member bodies). The work of preparing International Standards is normally carried out through ISO technical committees. Each member body interested in a subject for which a technical committee has been established has the right to be represented on that committee. International organizations, governmental and non-governmental, in liaison with ISO, also take part in the work. ISO collaborates closely with the International Electrotechnical Commission (IEC) on all matters of electrotechnical standardization.

The procedures used to develop this document and those intended for its further maintenance are described in the ISO/IEC Directives, Part 1. In particular the different approval criteria needed for the different types of ISO documents should be noted. This document was drafted in accordance with the editorial rules of the ISO/IEC Directives, Part 2. www.iso.org/directives

Attention is drawn to the possibility that some of the elements of this document may be the subject of patent rights. ISO shall not be held responsible for identifying any or all such patent rights. Details of any patent rights identified during the development of the document will be in the Introduction and/or on the ISO list of patent declarations received. www.iso.org/patents

Any trade name used in this document is information given for the convenience of users and does not constitute an endorsement.

For an explanation on the meaning of ISO specific terms and expressions related to conformity assessment, as well as information about ISO's adherence to the WTO principles in the Technical Barriers to Trade (TBT), see the following URL: [Foreword - Supplementary information](#)

The committee responsible for this document is ISO/TC 22, *Road vehicles*, Subcommittee SC 13, *Ergonomics applicable to road vehicles*.

This second edition cancels and replaces the first edition (ISO 15007-1:2002), of which it constitutes a minor revision.

ISO 15007 consists of the following parts, under the general title *Road vehicles — Measurement of driver visual behaviour with respect to transport information and control systems*:

- *Part 1: Definitions and parameters*
- *Part 2: Equipment and procedure* [Technical Specification]

Introduction

Vision provides the primary source of information available to a driver. Information is gathered by looking at objects and events and this in turn affords control and navigation of the vehicle in the road traffic environment. Assessment of a driver's visual behaviour provides a method of quantifying the driver's visual allocation to the roadway or in-vehicle information sources (see Reference^[1]).

Transport Information and Control Systems (TICS) applications for vehicles may have visual displays that can present a range of driver-selected information. If these visual displays have associated controls (e.g. to select a zoom level or menu option) then these associated hand-control activities may also be visually guided and become part of the visual behaviour associated with a display/TICS application. For this reason it may be important to consider not only the visual behaviour in relation to information display, but also the duration and frequency of glances following driver controlled actions.

Comparisons between specific vehicle systems have been made more difficult because the studies were conducted in different environments using different experimental techniques, different measurement definitions, and different analysis methods.

ISO 15007 has been developed to give guidance on the terms and measurements relating to the collection and analysis of driver visual behaviour data. This approach aims to assess how drivers respond to vehicle design, the road environment, or other driver-related tasks in both real and simulated road conditions. More specifically, the approach of this standard is based on the assumption that efficient processing of visual information is essential to the performance of the driving task.

ISO 15007-1 defines key terms and parameters applied in the analysis of driver visual behaviour focused on glance and glance related measurements. ISO 15007-2 gives guidelines on equipment and procedures for analysis of driver visual behaviour.

Practical assessments of drivers in real or simulated environments are conducted to quantify the allocation of visual behaviour to specified areas of interest. Visual behaviour may be quantified by the location, duration and frequency of glances to a specified area of interest in the visual scene (and, over time, between areas of interest). This approach often uses commonly available eye tracking and/or video-recording equipment. However, it does not preclude the use of more sophisticated technologies which may elicit additional driver visual behaviour information.

Results from such assessments should enable comparison of the relative influence of the TICS use with reference conditions.

Road vehicles — Measurement of driver visual behaviour with respect to transport information and control systems —

Part 1: Definitions and parameters

1 Scope

This part of ISO 15007 defines key terms and parameters applied in the analysis of driver visual behaviour focused on glance and glance-related measures. These terms and parameters can be applied in environments from real-world driving experiments to laboratory-based driving simulator studies.

The procedures described in this part of ISO 15007 could also apply to more general assessments of driver visual behaviour without the introduction of TICS-specific systems. The parameters and definitions described below are intended to assist development of a common source of reference for driver visual behaviour data.

Minimum requirements for reporting the results of Transport Information and Control Systems (TICS) evaluations are provided.

Further guidance including the specification of how to analyse and present the results of studies of visual behaviour is available in other ISO publications (see, for example, ISO 2854 and ISO/TR 13425:2006). However, data collected and analysed according to this standard will allow comparisons to be performed across different TICS applications and experimental scenarios.

2 Normative references

The following documents, in whole or in part, are normatively referenced in this document and are indispensable for its application. For dated references, only the edition cited applies. For undated references, the latest edition of the referenced document (including any amendments) applies.

ISO 2854, *Statistical interpretation of data — Techniques of estimation and tests relating to means and variances*

ISO/TR 13425:2006, *Guidelines for the selection of statistical methods in standardization and specification*¹⁾

ISO/TS 15007-2:2014, *Road vehicles — Measurement of driver visual behaviour with respect to transport information and control systems — Part 2: Equipment and procedures*

3 Terms and definitions

For the purposes of this document, the following terms and definitions apply.

3.1

accommodation

adjustment of the lens of the eye to bring about focusing of an image of an object upon the retina

Note 1 to entry: The time for the eye to accommodate from one object to another depends on the distance between the objects.

1) Withdrawn.

3.2 adaptation

ability of the eye to adjust to changing light conditions

Note 1 to entry: Adaptation times to transition from dark to light and light to dark are different.

3.3 direction of gaze

area of interest to which the eyes are directed

3.4 fixation

alignment of the eyes so that the image of the fixated area of interest falls on the fovea (the middle of the retina responsible for our central, sharpest vision) for a given time period

Note 1 to entry: Typically, individual fixations last from 100 ms to 2 000 ms (see Reference[3]). Fixations are the briefest of pauses during which visual information extraction is done by the eyes-and-brain from spatial areas that fall on the fovea of the eye (and hence are quite small). During fixation, there are believed to be at least three processes taking place (see Reference[10]): 1) analysis of the image falling on the fovea, 2) selection of a new saccade target and 3) programming of the saccade to-be-made-next. It is not yet known how these processes are synchronized by the brain, nor how precisely they are synchronized – since fixation durations are not always long enough to comprehend completion of all the processes. (Sometimes the eyes move before information extraction from the site of fixation has been completed, as evidenced by frequent corrective return fixations to a site under some conditions that was fixated too briefly). There is evidence that the brain both pre-programs fixation duration, and also does “process-monitoring” during a fixation to determine if analysis of the foveal image is complete within the fixation’s duration.before moving on. Thus, fixation time is dependent on both the immediate stimulus and the history of prior fixations. The contribution of both components suggests that fixation time may depend on the task and the amount of useful information in the fixated display (or viewed information) (see Reference[4]).

See [A.1](#) to [A.4](#).

3.5 glance

maintaining of visual gaze within an area of interest, bounded by the perimeter of the area of interest; may be comprised of more than one fixation and saccades to and from it. Its duration is measured as “glance duration”

Note 1 to entry: A glance is a scientific construct that sums over one or more fixations that are made contiguously within a given area of interest (but one that is larger than the area corresponding to the eye’s foveal region – an area that usually requires more than one fixation to view). The construct of a glance, therefore, typically comprehends more than a single fixation and is a coarser unit of analysis than a single fixation (since it is summing over fixations that are contiguous in time and spatially proximal within an area of interest). (“Area of interest” is formally defined below in [3.11](#)). The construct of a “glance” is needed because often the salient questions in a study relate to the amount of contiguous time spent gazing at a particular area of interest (before the eyes move away from it). (Of course, in some instances, the “glance” construct is also necessary because some measurement approaches are not capable of the fine discriminations needed to identify individual fixations (spatially and temporally) – and can only discriminate at the spatial/temporal granularity of glances. Thus, “glances” are a coarser measure of visual information extraction by the eyes/brain from a continuously viewed but somewhat larger spatial region. Typical glance lengths vary by stimulus and task, but might (for example) range from 500 ms to 3 s for a task like “tuning the radio” (see Reference[7]).

See [A.1](#) to [A.4](#).

3.6 saccade

brief, fast movement of the eyes that changes the point of fixation

Note 1 to entry: Saccades reach velocities as high as 500/s (see Reference [6]), whereby the mean saccade ranges between 1° (text reading) to 5° (scene perception) (see Reference [9]).

See [A.1](#) to [A.4](#).

3.7

smooth pursuit movement

smooth, continuous movement of the eyes made to closely follow/pursue a moving object or signal;

Note 1 to entry: Humans generally perform smooth pursuit movements better in the horizontal than vertical dimension, and better in the downward than upward direction. Smooth pursuit movements can have a velocity as high as $90^\circ/\text{s}$ (see Reference [5]).

3.8

blink

short moment in which the eye is closed by the eyelid

Note 1 to entry: The blink starts when the eyelid starts moving downwards and ends when the eye is fully opened again. According to the duration for which the eye is closed the following classification applies (see Reference [8]):

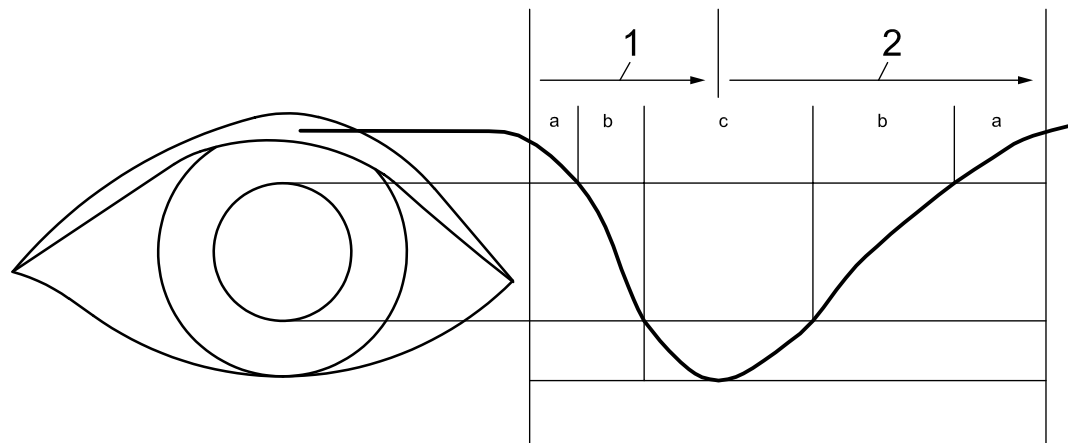

- Normal blinks: ≤ 300 ms (mean duration 257 ms; standard deviation 11 ms)
- Long closed durations: 300 ms to 500 ms
- Eye-lid closures: ≥ 500 ms (indicating microsleeps)

Key

- 1 closing phase
- 2 opening phase
- a open
- b partially closed
- c closed

Figure 1 — Phases of a blink (see Reference [11])

3.9

fly through (artfactual fixation)

small 'snapshot' of a saccade (<120 ms) that may be an artefact captured when the eye is moving from one Area of Interest to another Area of Interest, and passing through one or more intermediate Areas of Interest in between (e.g. the eye moves from the road scene ahead to the instrument cluster and passes the head-up display)

Note 1 to entry: Sometimes a small 'snapshot' of such a saccade may appear to be a short fixation, when it is really still part of the saccade. Such fly throughs (<120 ms) are not treated as fixations. Fly throughs may be grouped with the saccade they are part of, if saccades are being measured.

Note 2 to entry: Research shows that fixations can't be shorter than 100 ms (See Reference [6]).

3.10
sample interval

time period that constitutes a sample of interest (e.g. an in-vehicle task) in the data; or, to put it differently, the epoch of time over which measurements are taken

Note 1 to entry: Usually, this will be the contiguous epoch of time that is associated with an event or task that is of interest in the study. The sample interval is the period of time (from start to end) during which data are extracted.

3.11
area of interest

AOI
pre-determined area within the visual scene, e.g. a rear-view mirror

Note 1 to entry: An AOI will be no smaller than the normal resolution of the eye-measurement system being used (e.g. no smaller than 0.5° for typical eye-tracking systems)

See [A.1](#).

3.12
transition

change in eye fixation location from one defined area of interest location to a different defined area of interest

SEE: [A.1](#) and [A.2](#).

3.13
visual angle

angle subtended at the eye by a viewed object or separation between viewed objects

Note 1 to entry: The figure below shows the visual angle α .

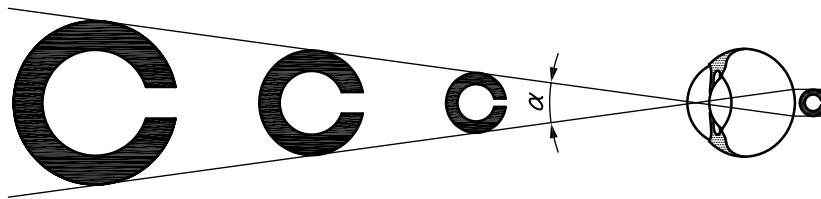

Figure 2 — Visual Angle α

3.14
visual demand

degree or quantity of visual activity (determined by e.g. number of glances, total glance time) required to extract information from an object to perform a specific task

SEE: [A.1](#).

3.15
visual display

device used to present visual information

SEE: [A.1](#).

4 Definition of measures and metrics

The measures and statistics defined in this clause utilize the terms and definitions defined in [Clause 3](#).

4.1 Basic Direct Measures

4.1.1 duration of diversion: period of glance duration(s) associated with directions of gaze away from one area of interest to another area of interest during a defined period of interest.

See [A.3](#).

4.1.2 dwell time: sum of consecutive individual fixation and saccade times to an area of interest in a single glance.

See [A.4](#).

4.1.3 glance duration: time from the moment at which the direction of gaze moves towards an area of interest (e.g. the inside rear-view mirror) to the moment it moves away from it.

NOTE Under certain specific conditions, this may be operationalized differently. See footnote in [A.2](#).

See [A.2](#).

4.1.4 transition time: duration between the end of the last fixation on an area of interest and the start of the first fixation on another area of interest.

See [A.2](#).

4.1.5 scan duration: time interval consisting of two or more glances that are linked in a consecutive set of fixations to areas of interest in the visual scene.

4.1.6 minimum glance duration: shortest possible duration for a fixation to an area of interest.

NOTE Fixations to an area of interest ≤ 120 ms are physically not possible; If an eye-tracker is in use and records such a duration it can be classified as part of a transition between areas of interest.

4.2 Glance Metrics Derived From Basic Measures

In this subclause, each derived metric is defined, a unit is specified, and an example is provided.

NOTE 1 Examples are illustrative only. Examples do not provide 'typical' values, since typical values depend strongly on the task and the AOI. They are meant only to illustrate the use of units.

NOTE 2 Definitions for the terms "road-scene ahead", "traffic related areas of interest" and "non-traffic related areas of interest" are given in ISO/TS 15007-2:2014, 7.1.

All glance measures except [4.2.1](#) shall be reported to the nearest hundredth of its respective unit, e.g. 17,88 s. (renumber items below)

4.2.1 number of glances: count of glances to an area of interest (or set of related Areas of Interest) during a condition, task, subtask or sub-subtask. Unit [count].

EXAMPLE 9 glances

4.2.2 total glance time: summation of all glance durations to an area of interest (or set of related Areas of Interest) during a condition, task, subtask or sub-subtask.

Total glance time = $\sum(\text{glance duration } 1, \text{ glance duration } 2, \dots, \text{ glance duration } n)$ unit [s]

EXAMPLE 17,88 s

4.2.3 mean glance duration: mean duration of all glance durations to an area of interest (or set of related Areas of Interest) during a condition, task, subtask or sub-subtask.

Mean glance duration = (Total Glance Time)/(Number of glances) during a condition, task or subtask;
unit [s]

EXAMPLE 1,28 s

4.2.4 glance rate: number of glances per unit of time.

Glance rate = (Number of glances)/(duration of condition, task, subtask or sub-subtask); unit [number of glances/s]

EXAMPLE 0,53 glances/s

NOTE To obtain glance rate to a task, only glances to the task would be counted, and divided by the duration of condition, task, subtask or sub-subtask. To obtain glance rate to all locations during a test scenario, all glances to all locations would be counted, and the total divided by the total length of the condition, task, subtask or sub-subtask.

4.2.5 Percent Time on Area of Interest: ratio representing the percent of time glances are within an area of interest (or set of related Areas of Interest) during a condition, task, subtask or sub-subtask.

Area of Interest attention ratio = $\sum(\text{glance duration } 1, \text{ glance duration } 2, \dots, \text{ glance duration } n) / (\text{duration of condition, task, subtask or sub-subtask}) \cdot 100 \%$; unit [%]

EXAMPLE 53,47 %

4.2.6 maximum glance duration: the longest glance duration to an area of interest (or set of related Areas of Interest) during a condition, task, subtask or sub-subtask.

Maximum glance duration = max [glance duration 1, glance duration 2, ..., glance duration n]; unit [s]

EXAMPLE 2,12 s

4.2.7 glance location probability: probability that the eyes are fixated at an area of interest (or set of related Areas of Interest) during a condition, task, subtask or sub-subtask.

Glance location probability = Number of glances to an Area of Interest during a condition, task, subtask or sub-subtask / (Number of glances to all areas of interest during a condition, task, subtask or sub-subtask) · 100 %; unit [%]

EXAMPLE 7,85 %

4.2.8 link value probability: probability of a glance transition between two different areas of interest during a condition, task, subtask or sub-subtask.

Link value probability between Area of Interest A and Area of Interest B = (number of glance transitions from A to B + the number of glance transitions from B to A) / (number of glance transitions between all areas of interest) · 100 %; unit [%]

EXAMPLE 17,39 %

4.2.9 total eyes off road time (TEORT): the summation of all glance durations to areas of interest other than the road scene ahead during a condition, task, subtask or sub-subtask.

TEORT = $\sum(\text{glance durations to Areas of Interest defined as off road-scene-ahead})$; unit [s]

EXAMPLE 103,32 s

NOTE 1 According to ISO/TS 15007-2 the road scene ahead excludes driver's rear-view mirror glances.

NOTE 2 This metric has to be operationalized in an appropriate way for each study – since the concept of “not on the road” may comprehend different areas of interest depending upon study objectives. When TEORT is utilized, clearly specify which Areas of Interest are counted on the road-scene ahead and which Areas of Interest are defined as off the road scene ahead.

4.2.10 percentage of eyes off road time (PEORT): percentage of time during a condition, task, subtask or sub-subtask (i.e. during a sample interval of interest) that glances are not on the road-scene-ahead.

Percentage of eyes off roadtime = $(TEORT)/(duration\ of\ condition,\ task,\ subtask\ or\ sub-subtask) \cdot 100\ \%$; unit [%]

EXAMPLE 41,29 %

4.2.11 percentage transition time: percentage of time during a condition, task, subtask or sub-subtask (i.e. during a sample interval of interest) during which the eyes are in transition (or are in movement between areas-of-interest).

Percentage transition time = $\sum(\text{transition time } 1, \text{ transition time } 2, \dots, \text{ transition time } n)/(duration\ of\ condition,\ task,\ subtask\ or\ sub-subtask) \cdot 100\ \%$; unit [%]

EXAMPLE 3,23 %

5 Data collection and analysis

The following data collection and analysis methods are recommended reading:

- [Annex A](#) provides some guidance on the categorization and interpretation of experimental data;
- Guidance on the collection and analysis of driver visual behaviour data are provided in ISO 15007-2;
- Guidance of how to treat missing data are provided in ISO 15007-2:2014, Annex A;
- Guidance for statistical interpretation of data are given in ISO 2854 and ISO/TR 13425:2006²⁾.

6 Data presentation

To enable consistent recording of comparable data on TICS evaluation, common summary information should be reported. Results from evaluation trials should include the following parameters per sample interval for each area of interest, experimental condition, subject and a summary for all subjects:

- a) Condition duration, task duration, subtask duration or sub-subtask duration (mean and standard deviation);
- b) Total glance time (mean and standard deviation);
- c) Mean glance duration (mean and standard deviation);
- d) Maximum glance duration (mean and standard deviation);
- e) Area of Interest attention ratio (mean and standard deviation);
- f) Glance rate (mean and standard deviation);
- g) Additional statistics and measurement details;

2) Withdrawn.

Where possible, results from evaluation trials should also include the following measurements for each area of interest, experimental condition, subject and a summary for all subjects:

- Range;
- 10th, 85th and 90th percentiles;
- Percentage of extended duration glances (e.g. glances over 2 sec).

Any exclusion of data recorded from a trial, such as static vehicle occurrences or uncontrolled subject reactions, shall be defined and reported to ensure a consistent interpretation of results.

Annex A (informative)

Supporting Figures to explain terms and definitions

A.1 Visual behaviour in the vehicle

Visual behaviour in the vehicle is a function of the complexity of the information being presented, and the difficulty of extracting that information from the surrounding visual environment (e.g. the duration and/or frequency of glances required). Besides that, visual behaviour is also strongly determined by the drivers motivation to engage in a task.

Various parameters may be calculated from the distribution of the driver's eye movements around the specified areas of interest in the visual scene. The visual demand associated with specific areas of interest may be inferred from the various parameters that can be calculated from this data.

Driver visual behaviour typically consists of a series of fixations and saccades within a pre-determined area of interest followed by a transition to another area of interest. See [Figure A.1](#).

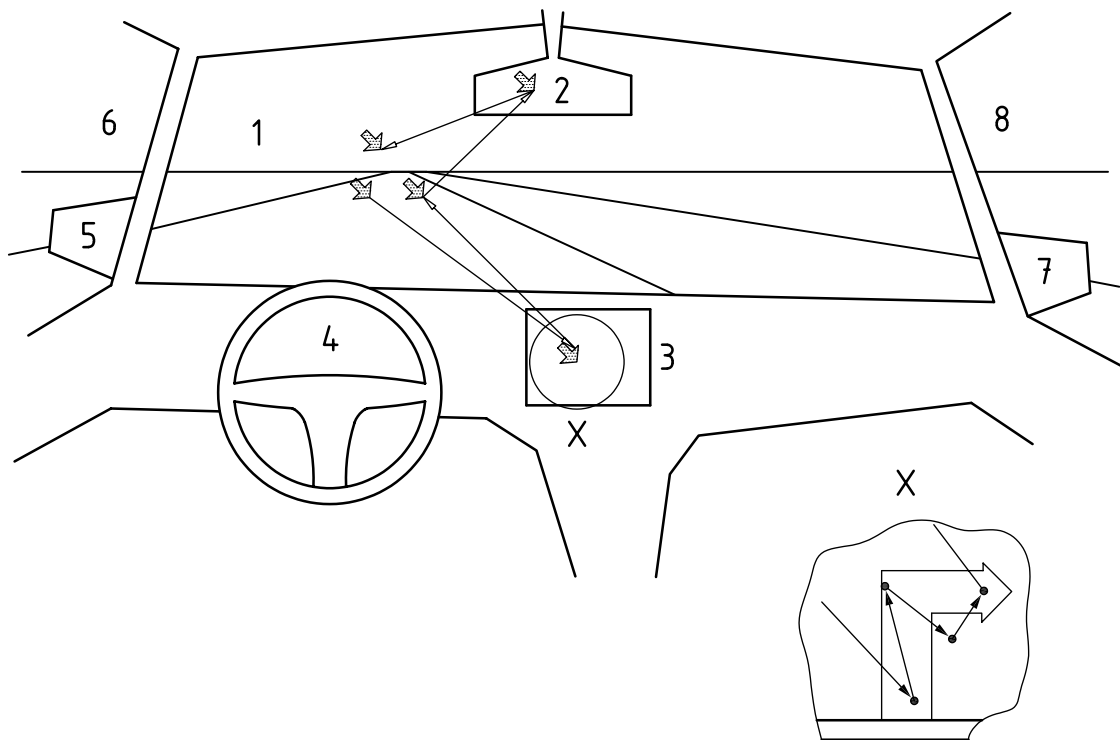

Key

1	road scene ahead	↔	transition time
2	inside mirror	↔•	dwell time
3	TICS display	→	saccade
4	instrument cluster	•	fixation
5	outside mirror driver side		
6	side window driver side		
7	outside mirror passenger side		
8	side window passenger side		

8 side window passenger side

NOTE Picture is valid for left steered cars.

Figure A.1 — Pre-defined areas of interest and an illustration of example driver fixation

A.2 Glance duration

A single glance duration may also be simply referred to as a glance. It should be noted that glance duration includes the transition time to an area of interest³⁾ and the dwell time on that area of interest. There may also be some accommodation of the eyes during the transition time. See [Figure A.2](#).

$$\text{Glance_duration} = \text{Transition_time} + \text{Dwell_time}$$

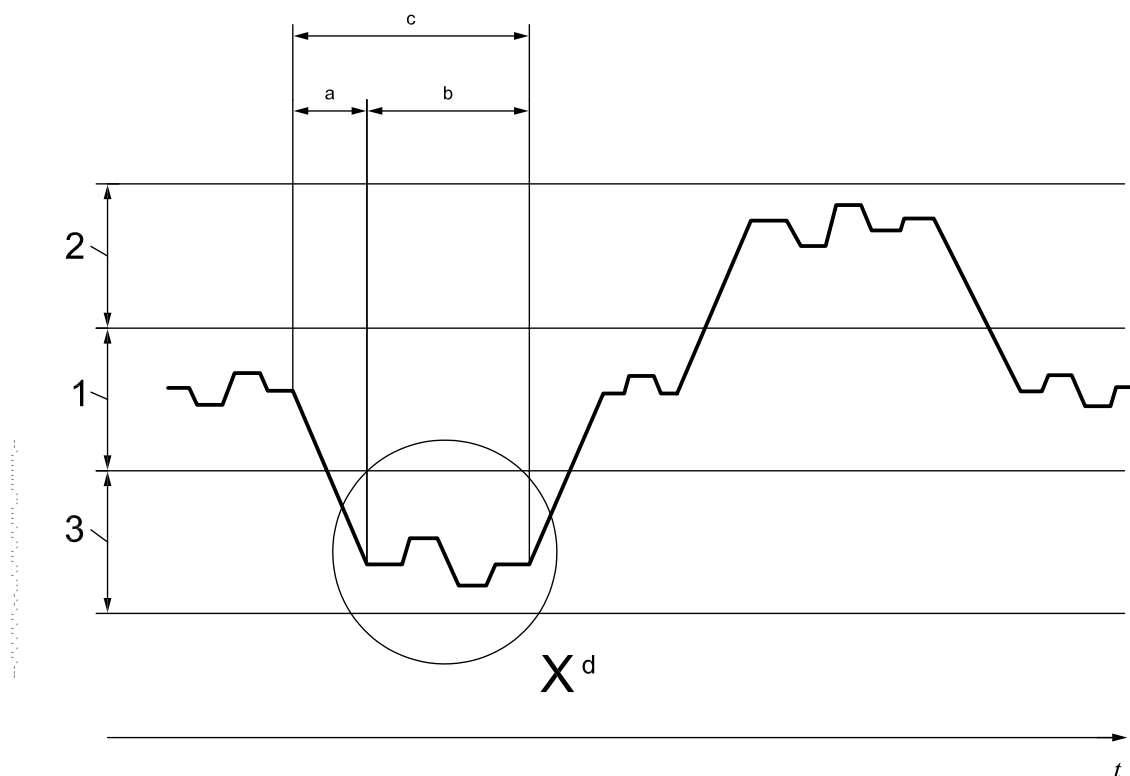

Key

- 1 destination A (e.g. road scene ahead)
- 2 destination B (e.g. inside mirror)
- 3 destination C (e.g. TICS display)
- a Transition time.
- b Dwell time.

3) Whenever possible, it is the transition which leads *toward* the area of interest on which the dwell occurs that is included in the measurement of a glance. This is done to reflect, or capture, the shift of attention toward the point of dwell. That attentional shift starts at the point where the leading transition begins. However, it is sometimes not practical or technically possible to capture the leading transition (for example, when scoring glances manually from video). Therefore, in instances where the leading and trailing transitions are of equivalent lengths, it is permissible to use the trailing transition instead of the leading transition in measuring the glance (glance = dwell + the trailing transition). This is not ideal (given that it does not reflect the close relationship of attention and eyes) – but is an acceptable measurement compromise, if applied carefully – one that should not produce any discernible difference in glance lengths (as long as leading and trailing transitions are of equivalent length). Example: The pattern of glancing tends to be one where the locus of gaze moves from the road to a navigation display and then back to the road.

- c Glance duration.
 X^d See [Figure A.4](#)

Figure A.2 — Chronological relationship of driver visual allocation between areas of interest

A.3 Duration of diversion

See [Figure A.3](#).

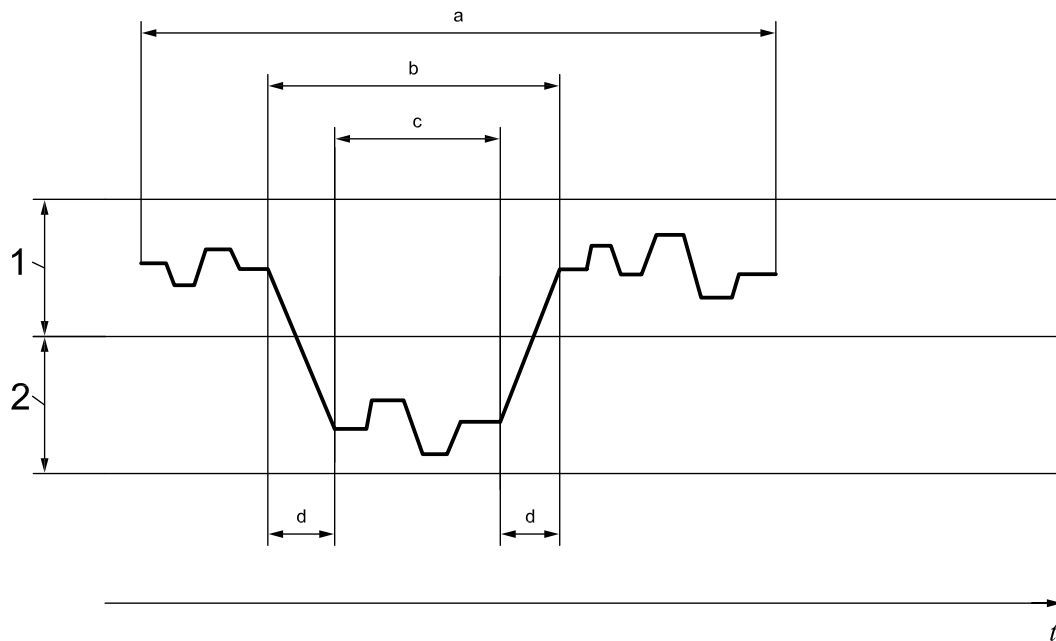

Key

- 1 destination A (e.g. road scene ahead)
- 2 destination C (e.g. TICS display)
- a Sampling interval.
- b Duration of diversion.
- c Dwell time.
- d Transition time.

Figure A.3 — Duration of diversion away from the road scene ahead

A.4 Dwell time

Dwell time is measured as the time period from when a driver first fixates on an area of interest until the eyes shift to a different area of interest. See [Figure A.4](#).

$$\text{Dwell_time} = F_1 + S_1 + F_2 + S_2 + \dots + F_n + S_{n-1}$$

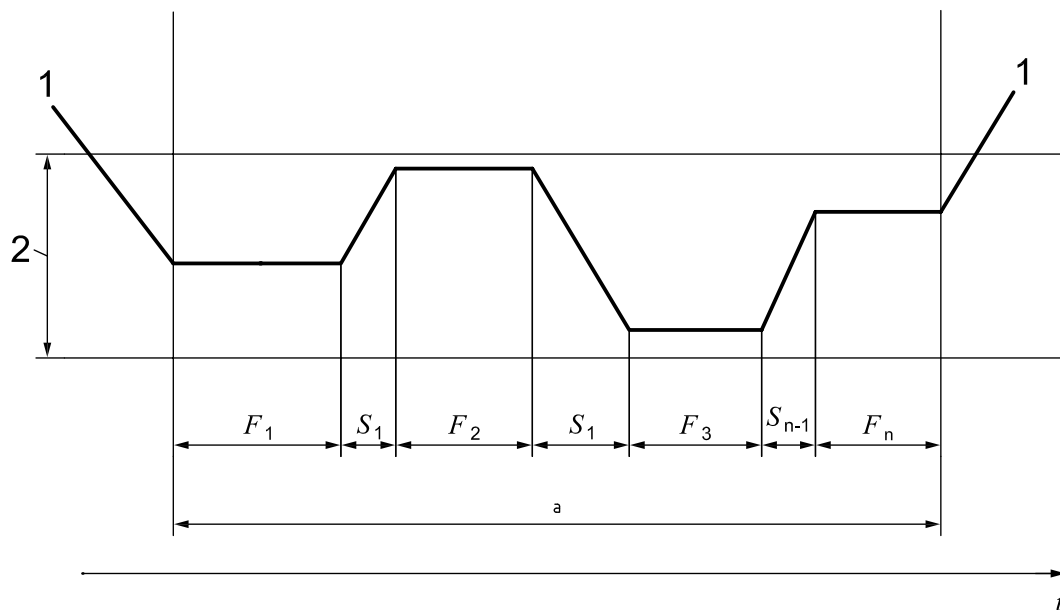

Key

- 1 transition
- 2 destination
- F fixation
- S saccade
- a Dwell time.

NOTE Destination area of interest is indicated by the horizontal lines which appear within the band labelled "destination").

Figure A.4 — Chronological relationship between fixations and saccades during dwell time to one area of interest

Bibliography

- [1] ALLEN M.J., ABRAMS B.S., GINSBERG A.P., WEINTRAUB L. *Forensic Aspects of Vision and Highway Safety*. Lawyers & Judges. Publishing Company Inc. 2000, **ISBN-10** p. 1930056036
- [2] GREEN P. to appear. . In: *Human Factors in Traffic Safety*, (SMILEY A. ed.). Lawyers and Judges Publishing, Tucson, AZ, Third Edition, 2011
- [3] KARSH R., & BREITENBACH F.W. . In: *Eye Movements and Psychological Functions: International Views*, (GRONER R., MENZ C., FISHER D.F., MONTY R.A. eds.). Erlbaum, Hillsdale, NJ, 1983, pp. 53–64.
- [4] OVER E.A., HOOGE I.T., VLASKAMP B.N., ERKELENS C.J. 2007. [Coarse-to-fine eye movement strategy in visual search](#). In. *Vision Res.* 2007 Aug;47(17):2272-80. Epub 2007 Jul 6
- [5] MEYER Ch. Lasker, Ag., Robinson, Da. The upper limit of human smooth pursuit velocity. *Vision Res.* 1985, **34** pp. 561–563
- [6] RAYNER K. Eye Movements in Reading and Information Processing: 20 Years of Research. *Psychol. Bull.* 1998, **124** () pp. 372–422
- [7] ROCKWELL T.H. 1988). *Spare visual capacity in driving – revisited*. In A. G. Gale et al. Eds.), *Vision in Vehicles II* (pp. 317-324). Amsterdam: Elsevier. Sivak M, 1996, “The information that drivers use: is it indeed 90% visual?” *Perception* 25(9) 1081 – 1089
- [8] STERN J.A., & SKELLY J.J. 1984. *The eyeblink and workload considerations*. Proceedings of the human factors society, 28th Annual meeting Santa Monica: Human Factors Society
- [9] VELICHKOVSKY B., DOMHOEFER S.M., PANNASCH S. Unema P.J.A(). *Visual Fixations and Level of Attentional Processing*. Eye-Tracking Research & Applications Symposium 2000, Palm Beach Gardens, FL, USA)
- [10] VIVIANI P. 1990. *Eye movements in visual search: Cognitive, perceptual and motor control aspects*. In E. Kowler (ed.), *Reviews of oculomotor research: Vol. 4: Eye movements and their role in visual and cognitive processes* (pp. 353 – 383). Amsterdam: Elsevier
- [11] WILD H. 1983. *Experimentelle Untersuchungen über die zeitliche Verteilung der spontanen Lidschlussereignisse*. Dissertation am Psychologischen Institut der Universität Innsbruck. Innsbruck: Universität Innsbruck

.....