

First edition
2010-06-15

**Plastics pipes and fittings — Format of a
technical file for characterizing PE spigot
end fittings**

*Tubes et raccords en matières plastiques — Modèle d'une fiche
technique caractérisant les raccords à bouts mâles en polyéthylène*



Reference number
ISO/TS 19911:2010(E)

© ISO 2010

PDF disclaimer

This PDF file may contain embedded typefaces. In accordance with Adobe's licensing policy, this file may be printed or viewed but shall not be edited unless the typefaces which are embedded are licensed to and installed on the computer performing the editing. In downloading this file, parties accept therein the responsibility of not infringing Adobe's licensing policy. The ISO Central Secretariat accepts no liability in this area.

Adobe is a trademark of Adobe Systems Incorporated.

Details of the software products used to create this PDF file can be found in the General Info relative to the file; the PDF-creation parameters were optimized for printing. Every care has been taken to ensure that the file is suitable for use by ISO member bodies. In the unlikely event that a problem relating to it is found, please inform the Central Secretariat at the address given below.



COPYRIGHT PROTECTED DOCUMENT

© ISO 2010

All rights reserved. Unless otherwise specified, no part of this publication may be reproduced or utilized in any form or by any means, electronic or mechanical, including photocopying and microfilm, without permission in writing from either ISO at the address below or ISO's member body in the country of the requester.

ISO copyright office
Case postale 56 • CH-1211 Geneva 20
Tel. + 41 22 749 01 11
Fax + 41 22 749 09 47
E-mail copyright@iso.org
Web www.iso.org

Published in Switzerland

Foreword

ISO (the International Organization for Standardization) is a worldwide federation of national standards bodies (ISO member bodies). The work of preparing International Standards is normally carried out through ISO technical committees. Each member body interested in a subject for which a technical committee has been established has the right to be represented on that committee. International organizations, governmental and non-governmental, in liaison with ISO, also take part in the work. ISO collaborates closely with the International Electrotechnical Commission (IEC) on all matters of electrotechnical standardization.

International Standards are drafted in accordance with the rules given in the ISO/IEC Directives, Part 2.

The main task of technical committees is to prepare International Standards. Draft International Standards adopted by the technical committees are circulated to the member bodies for voting. Publication as an International Standard requires approval by at least 75 % of the member bodies casting a vote.

In other circumstances, particularly when there is an urgent market requirement for such documents, a technical committee may decide to publish other types of document:

- an ISO Publicly Available Specification (ISO/PAS) represents an agreement between technical experts in an ISO working group and is accepted for publication if it is approved by more than 50 % of the members of the parent committee casting a vote;
- an ISO Technical Specification (ISO/TS) represents an agreement between the members of a technical committee and is accepted for publication if it is approved by 2/3 of the members of the committee casting a vote.

An ISO/PAS or ISO/TS is reviewed after three years in order to decide whether it will be confirmed for a further three years, revised to become an International Standard, or withdrawn. If the ISO/PAS or ISO/TS is confirmed, it is reviewed again after a further three years, at which time it must either be transformed into an International Standard or be withdrawn.

Attention is drawn to the possibility that some of the elements of this document may be the subject of patent rights. ISO shall not be held responsible for identifying any or all such patent rights.

ISO/TS 19911 was prepared by Technical Committee ISO/TC 138, *Plastics pipes, fittings and valves for the transport of fluids*, Subcommittee SC 5, *General properties of pipes, fittings and valves of plastic materials and their accessories — Test methods and basic specifications*.

Introduction

The technical file of a spigot end fitting describes the identification of the fitting, the main characteristics of the PE compound and the geometrical characteristics of the fitting, including the manufacturing tolerances of the product.

The technical file can be used to characterize the fitting for type testing and approval by third party certification procedures. Each modification on the fitting is reflected can be a revised technical file. Based on the contents of the revised technical file, further approval or complementary testing can be considered.

Plastics pipes and fittings — Format of a technical file for characterizing PE spigot end fittings

1 Scope

This Technical Specification describes the individual elements of a technical file, specifying the characteristics of fittings with spigot ends for butt fusion or electrofusion assembling.

All details described in this Technical Specification are provided by the manufacturer of the butt fusion fitting.

2 Normative references

The following referenced documents are indispensable for the application of this document. For dated references only the edition cited applies. For undated references the latest edition of the referenced document (including any amendments) applies.

ISO 1133, *Plastics — Determination of the melt mass-flow rate (MFR) and the melt volume-flow rate (MVR) of thermoplastics*

ISO 12162, *Thermoplastics materials for pipes and fittings for pressure applications — Classification, designation and design coefficient*

ISO 12176-4, *Plastics pipes and fittings — Equipment for fusion jointing polyethylene systems — Part 4: Traceability coding*

3 Description of the spigot end fitting

The manufacturer's technical file shall include the information, as described in Tables 1 and 2, for the identification of the fitting and the PE compound used.

Table 1 — Identification of the fitting

Name of the manufacturer	
Trade mark of the fitting	
Type of fitting (tee, elbow, reducer, etc.)	
Application, e.g. water and gas	
Detailed explanation of the identification coding of the fitting	
Nominal diameter(s) and SDR	
Compliance with product standard(s)	

Table 2 — Characteristics of the PE compound

Trade mark	
Classification of compound in accordance with ISO 12162, e.g. PE100	
Compound code in accordance with ISO 12176-4	
Melt mass-flow rate, e.g. MFR(190/5) indicating temperature and load used in the test, in accordance with ISO 1133, of the compound and tolerances, if not provided by the product standard	
Colour of the compound	

4 Geometrical characteristics of the fitting

The manufacturer's technical file shall provide all relevant dimensions in millimetres. At a minimum, the dimensions related to the symbols shown in Figure 1 and Table 3 shall be provided.

The dimensions used in Table 3 are in conformity with the relevant product standard.

The dimensions shown in Figure 1 and Table 3 are the following:

- D_1 the mean outside diameter of the fusion end-piece, measured in any plane parallel to the plane of the mouth and at a distance not greater than L_2 from that plane;
- D_2 the mean outside diameter of the body of the fitting;
- D_3 the minimum bore which comprises the minimum diameter of the flow channel through the body of the fitting. This diameter does not include the fusion bead if any;
- E the thickness of the fitting measured at any point on the wall of the fitting;
- E_s the thickness of the fusion-face wall, measured at any point at a maximum distance, L_1 (cut-back length) from the mouth;
- L_1 the length of the cut-back section of the fusion end-piece, which comprises the initial depth of the spigot and which is necessary for butt fusion or electrofusion;
- L_2 the tubular length, which comprises the length of the initial, tubular, section of the fusion end-piece;
- L overall dimensions of the fitting defined by the manufacturer;
- Ovality out-of-roundness (ovality) of D_1 measured at any point of L_1

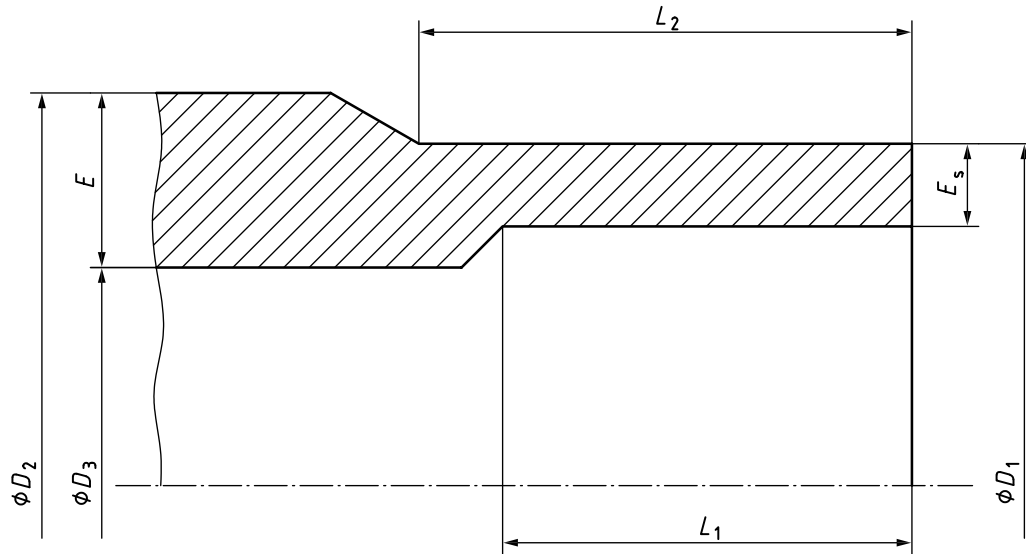

Figure 1 — Geometrical characteristics of the spigot end fitting

Table 3 — Dimensions and tolerances

Dimension	Unit	Nominal	Minimum	Maximum
D_1^a	mm			
D_2	mm			
D_3	mm			
E	mm			
E_s^b	mm			
L_1	mm			
L_2	mm			
L	mm			
Ovality (D_1) ^a	mm			
<p>^a These values conform to the product standard or specification.</p> <p>^b Face thickness reductions due to chamfering of the edge or circumferential reversion when made out of pipe shall be included.</p>				

The white areas of Table 3 are to be completed.

5 Fusion parameters

If required, the manufacturer may provide a butt fusion procedure with the technical file.

ICS 23.040.45; 23.040.60

Price based on 3 pages