**Safety of pressure swing adsorption
systems for hydrogen separation and
purification**

*Système d'adsorption modulée en pression pour la séparation et la
purification de l'hydrogène*





COPYRIGHT PROTECTED DOCUMENT

© ISO 2017, Published in Switzerland

All rights reserved. Unless otherwise specified, no part of this publication may be reproduced or utilized otherwise in any form or by any means, electronic or mechanical, including photocopying, or posting on the internet or an intranet, without prior written permission. Permission can be requested from either ISO at the address below or ISO's member body in the country of the requester.

ISO copyright office
Ch. de Blandonnet 8 • CP 401
CH-1214 Vernier, Geneva, Switzerland
Tel. +41 22 749 01 11
Fax +41 22 749 09 47
copyright@iso.org
www.iso.org

Contents

Page

Foreword	iv
1 Scope	1
2 Normative references	1
3 Terms and definitions	2
4 Basic specification	3
4.1 Feed stream pressure.....	3
4.2 Working temperature.....	4
4.3 Assembly.....	4
4.4 Material properties.....	4
4.4.1 Feed stream pressure.....	4
4.4.2 Working temperature.....	4
5 Safety requirements of the PSA system	4
5.1 General hazards associated with the PSA system.....	4
5.1.1 General hazards associated with hydrogen gas.....	4
5.1.2 General hazards associated with system leakage.....	4
5.1.3 Hazards related to pressure.....	4
5.1.4 Hazards related to ignition of hydrogen.....	5
5.2 Safety specifications in the field.....	5
5.2.1 General hazards.....	5
5.2.2 Layout considerations.....	5
5.2.3 Buildings and ventilation.....	5
5.2.4 Explosion-proof area and explosion-proof grade.....	6
5.2.5 Electrostatic grounding.....	7
5.2.6 Flammable and toxic gas detection alarm.....	7
5.3 Safety specifications of equipment and piping.....	8
5.3.1 General specification.....	8
5.3.2 Safety specifications of adsorbers.....	8
5.3.3 Safety specifications of the buffer tank.....	9
5.3.4 Safety specifications of process control valves.....	9
5.3.5 Safety specifications of piping.....	9
5.3.6 Safety considerations for operations and maintenance.....	10
5.3.7 Safety specifications of inspection and test.....	10
5.3.8 Safety specifications of electrical equipment.....	11
5.3.9 Safety specifications of monitoring devices.....	12
Annex A (informative) Example of potential locations of relief valves	14
Bibliography	15

Foreword

ISO (the International Organization for Standardization) is a worldwide federation of national standards bodies (ISO member bodies). The work of preparing International Standards is normally carried out through ISO technical committees. Each member body interested in a subject for which a technical committee has been established has the right to be represented on that committee. International organizations, governmental and non-governmental, in liaison with ISO, also take part in the work. ISO collaborates closely with the International Electrotechnical Commission (IEC) on all matters of electrotechnical standardization.

The procedures used to develop this document and those intended for its further maintenance are described in the ISO/IEC Directives, Part 1. In particular the different approval criteria needed for the different types of ISO documents should be noted. This document was drafted in accordance with the editorial rules of the ISO/IEC Directives, Part 2 (see www.iso.org/directives).

Attention is drawn to the possibility that some of the elements of this document may be the subject of patent rights. ISO shall not be held responsible for identifying any or all such patent rights. Details of any patent rights identified during the development of the document will be in the Introduction and/or on the ISO list of patent declarations received (see www.iso.org/patents).

Any trade name used in this document is information given for the convenience of users and does not constitute an endorsement.

For an explanation on the meaning of ISO specific terms and expressions related to conformity assessment, as well as information about ISO's adherence to the World Trade Organization (WTO) principles in the Technical Barriers to Trade (TBT) see the following URL: www.iso.org/iso/foreword.html.

This document was prepared by Technical Committee ISO/TC 197, *Hydrogen technologies*.

Safety of pressure swing adsorption systems for hydrogen separation and purification

1 Scope

This document identifies safety measures and applicable design features that are used in the design, commissioning, and operation of pressure swing adsorption systems for hydrogen separation and purification. It applies to hydrogen pressure swing adsorption systems that process all kinds of impure hydrogen streams as feed, including both stationary and skid-mounted pressure swing adsorption systems for hydrogen separation and purification in commercial or industrial use. This document also applies to small-scale PSA hydrogen system installed within containers, where allowed by local regulations.

The scope of this document includes the equipment depicted within the dashed lines in [Figure 1](#).

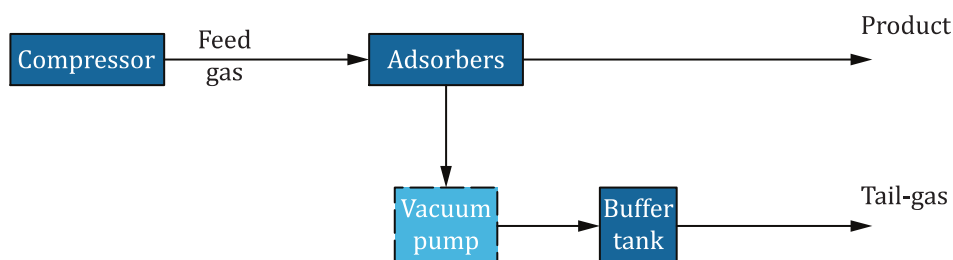

Figure 1 — Example of typical equipment in PSA system for hydrogen separation and purification

2 Normative references

The following documents are referred to in the text in such a way that some or all of their content constitutes requirements of this document. For dated references, only the edition cited applies. For undated references, the latest edition of the referenced document (including any amendments) applies.

ISO 4126-1, *Safety devices for protection against excessive pressure — Part 1: Safety valves*

ISO 11114-1, *Gas cylinders — Compatibility of cylinder and valve materials with gas contents — Part 1: Metallic materials*

ISO 11114-2, *Gas cylinders — Compatibility of cylinder and valve materials with gas contents — Part 2: Non-metallic materials*

ISO 11114-4, *Transportable gas cylinders - Compatibility of cylinder and valve materials with gas contents — Part 4: Test methods for selecting metallic materials resistant to hydrogen embrittlement*

IEC 60079-0, *Explosive atmospheres — Part 0: Equipment — General requirements*

IEC 60079-10-1, *Explosive atmospheres — Part 10-1: Classification of areas — Explosive gas atmospheres*

IEC 60079-14, *Explosive atmospheres — Part 14: Electrical installations design, selection and erection*

IEC 60204-1, *Safety of machinery — Electrical equipment of machines — Part 1: General requirements*

IEC 60529, *Degrees of protection provided by enclosures (IP Code)*

IEC 60364-4, *Low-voltage electrical installations — Part 4: Protection for safety*

NFPA 56, *Standard for Fire and Explosion Prevention during Cleaning and Purging of Flammable Gas Piping Systems*

3 Terms and definitions

For the purposes of this document, the following terms and definitions apply.

ISO and IEC maintain terminological databases for use in standardization at the following addresses:

- IEC Electropedia: available at <http://www.electropedia.org/>
- ISO Online browsing platform: available at <http://www.iso.org/obp>

**3.1
pressure swing adsorption method
PSA method**
gas separation method that takes advantage of the selective adsorption of a solid *adsorbent* (3.5) for different gases and the ability of solid adsorbents to adsorb more impurities at high pressure and to reject impurities at low pressure

Note 1 to entry: PSA, as practiced commercially, is a batch process utilizing multiple adsorbent-loaded vessels for the continuous purification of a gas stream.

**3.2
vacuum pressure swing adsorption**
system for hydrogen separation and purification that relies on desorption at sub-atmospheric pressure (achieved with vacuum pumps) to improve the performance of the system

**3.3
pressure swing adsorption system for hydrogen separation and purification**
hydrogen generation system that separates and purifies hydrogen from an impure hydrogen stream through the pressure swing adsorption process

**3.4
adsorber**
vessel in which the *adsorbent* (3.5) used for hydrogen separation and purification is contained, which can be vertical vessels

**3.5
adsorbent**
solid materials used to adsorb gas impurities from the impure hydrogen streams, thereby realizing the separation of the hydrogen from the other gases

**3.6
process control valves**
operational devices that can open or close to regulate flow in response to a signal from the *control system* (3.7)

**3.7
control system**
system that performs operations such as opening and closing *process control valves* (3.6), system troubleshooting, product quality control, or optimization of process parameters

3.8**tail gas**

gas remaining after the impure hydrogen mixture is purified through the PSA system

Note 1 to entry: Other names for tail gas are desorbed gas, purge gas, or off gas.

3.9**stationary PSA system for hydrogen separation and purification**

PSA system in which all equipment and piping are permanently mounted to the equipment foundation(s) and piping support structure

3.10**skid-mounted PSA system for hydrogen separation and purification**

PSA system in which some or all of the equipment and piping are affixed to one or more skids, or moveable bases

3.11**fire separation distance**

distance between the PSA system and nearby *buildings* (3.15) that is required in order to prevent fire from spreading from a PSA system to nearby buildings

3.12**buffer tank**

vessel that receives the desorbed gas from the *adsorbers* (3.4) (PSA system) or from the *vacuum pumps* (3.13) (VSA system) and minimizes the composition and pressure variation of the desorbed gas

Note 1 to entry: A buffer tank may also be referred to as a surge drum.

3.13**vacuum pump**

device used for evacuating the *adsorbers* (3.4) during the desorption stage, allowing the *adsorbents* (3.5) to be desorbed and regenerated at sub-atmospheric pressure to improve performance of a PSA system

3.14**container**

enclosed construction or bracing structure fabricated to avoid the effects of specific environmental and climatic conditions, or protect personnel and livestock from accidental contact with the dangerous components of a small hydrogen PSA system

3.15**building**

structure that has a roof and walls, with the similar function as a *container* (3.14) for a hydrogen PSA system or the components of a hydrogen PSA system

3.16**hydrogen embrittlement**

degradation of metal material properties due to the presence of a hydrogen environment

4 Basic specification**4.1 Feed stream pressure**

PSA systems for hydrogen generation and purification typically have feed gas pressures ranging from 0,3 MPa to 6,0 MPa. The operating pressure cycles from full feed gas pressure during adsorption to near atmospheric pressure (0,03 MPa) or vacuum (-0,09 MPa) during desorption.

4.2 Working temperature

The normal working temperature is between 5 °C and 40 °C for a PSA system for hydrogen separation and purification.

4.3 Assembly

A PSA system for hydrogen separation and purification can be stationary or skid-mounted based on the end use of the hydrogen product and on the hydrogen throughput. Small PSA systems may be installed within containers, if allowed by local regulations.

4.4 Material properties

4.4.1 Feed stream pressure

Metallic and non-metallic materials used in the construction of internal or external parts of a PSA system for hydrogen separation and purification should be suitable for all physical, chemical, and thermal conditions, both test conditions and operating conditions, for the design lifetime of the equipment. The compatibility of materials shall be evaluated to comply with ISO 11114-1, ISO 11114-2, ISO/TR 15916 or local regulations.

4.4.2 Working temperature

When ferrous metal is used in a PSA system, adequate consideration and analysis shall be taken according to ISO/TR 15916, ISO 11114-4 or the local regulations. For the non-metal materials contacting with hydrogen, the hydrogen permeability shall be considered.

5 Safety requirements of the PSA system

5.1 General hazards associated with the PSA system

5.1.1 General hazards associated with hydrogen gas

Hydrogen is colourless, odourless, and highly flammable; it burns with a nearly invisible flame in daylight. It can form an explosive mixture with air, and its lower and upper explosive limits in air are 4 % and 75 % (percent by volume) at atmospheric temperature and pressure.

Hydrogen in air will displace oxygen and may result in asphyxia if the partial pressure of oxygen in air reduces due to high hydrogen concentration.

5.1.2 General hazards associated with system leakage

Due to its low molecular weight and small size, hydrogen leaks easily from flanges and other sealing surfaces (e.g. vent valves). Hydrogen is highly buoyant due to its low specific gravity, and it can form large areas of flammable or explosive gas. Because hydrogen is colourless, the extent of a flammable area is not readily identifiable.

5.1.3 Hazards related to pressure

Normal pressure swings during the PSA process will cause alternating stress on the adsorbers, process control valves, and piping, which could lead to cracks in the vessels or piping or to another failure mode.

The failure of hydrogen PSA equipment or piping can result in the rapid release of energy due to the high pressure of the equipment. The resulting shock wave may damage surrounding equipment.

5.1.4 Hazards related to ignition of hydrogen

Ignition of hydrogen due to a leak to atmosphere from a hydrogen PSA system will cause energy/heat release or explosion. As heat is released through combustion of hydrogen, the gas within the PSA system will expand due to the increase in external temperature, and the material properties of the PSA system may degrade. The combination of increasing temperature and pressure and degradation of the material properties could cause piping or vessel failure.

5.2 Safety specifications in the field

5.2.1 General hazards

Feed gases of the PSA systems for hydrogen separation and purification include syn-gas generated from natural gas, ammonia cracking gas, coal gas, coke oven gas, ammonia tail-gas, methanol off-gas, refinery off-gas, etc., and the hydrogen content may be more than 25 %. The oxygen content in the feed stream shall be restricted to ensure combustible gases, such as hydrogen, are away from their flammable limit.

PSA hydrogen systems shall be sited according to the requirements of the applicable national safety standards and the construction and materials requirements shall be based on the partial pressure of hydrogen. PSA designs shall account for all circumstances that are anticipated during the life of their operation. The PSA control system should be designed to move the PSA to a safe state on detection of a failure via the PSA control system.

A fire protection system shall be considered for a hydrogen PSA system. Possible fire protection measures include a means to shut down the PSA quickly (either automatic or manual), a sprinkler system, a deluge system, or a dry-chemical extinguishing system. Small fires may be extinguished by dry-chemical extinguishers, carbon-dioxide extinguishers, nitrogen, or steam. Water may be used to cool equipment adjacent to a hydrogen fire.

5.2.2 Layout considerations

The layout of equipment and buildings associated with a PSA system for hydrogen separation and purification shall conform to local requirements for fire separation distance.

When a valve skid is designed such that the piping and valves are arranged in multiple levels that cover a large horizontal area, platforms constructed of steel grating should be used to prevent a confined space where hydrogen could build a flammable atmosphere.

A PSA hydrogen system installed within a container shall be designed and constructed to avoid any reasonably foreseeable risk of fire or explosion posed by the system itself, or by the feed gas, product gas, or tail gas.

The containers shall have the strength, stability, durability, resistance to corrosion, and other physical properties to support and protect all PSA hydrogen system components and piping. Containers should also meet the requirements of storage, transport, installation, and final location conditions in accordance with ISO 16110-1 or other applicable national or local regulations.

Containers intended for indoor use shall be designed and tested to meet a minimum degree of protection of IP 20 as per IEC 60529. The PSA hydrogen system used in outdoor locations shall be designed and tested to meet a minimum degree of protection of IP 44 as per IEC 60529.

5.2.3 Buildings and ventilation

5.2.3.1 General

Small PSA systems for hydrogen separation and purification may be enclosed within a building. Other equipment associated with hydrogen PSA systems may be enclosed within one or more standalone buildings. Examples include valve skids, vacuum pump for desorbed gas, control systems, and analyzers.

5.2.3.2 Buildings

Buildings shall be designed to the appropriate hazardous area designation based on the potential for hydrogen to be present due to leaks or other breakdown (e.g. Zone 2 per IEC 60079-10-1).

The distances between buildings, structures and equipment shall comply with local requirements for fireproof distance.

Enclosed buildings, if utilized, shall be designed as explosion-proof type. Alternately, for non-explosion proof buildings, the ratio between the pressure relief area and the building volume shall comply with local regulations. The area used for pressure relief could be a light roof, a wall, a door, or a window.

5.2.3.3 Ventilation of buildings

Buildings shall be designed with ventilation equipment that is interlocked with flammable or toxic gas detectors.

When the provided ventilation influences the type of area classification, that area should be purged with a minimum of five air changes prior to energizing the devices. Alternatively, the system may be provided with composition measurement capabilities that control the amount of purging required to achieve levels below 25 % of the LEL.

Purging need not be performed if the atmosphere within the compartment and associated ducts can be demonstrated by design to be non-hazardous.

Appropriate methods shall be adopted to prevent non-essential staff from entering buildings and approaching equipment. The main entrance shall be constructed according to applicable specifications and regulations. Fire-fighting equipment shall be readily accessible.

Any building that staff can enter shall be equipped with an emergency exit opening outwards. Any door with a latch should be equipped with a rapid unlocking mechanism such that the door can be opened without delay.

5.2.3.4 PSA hydrogen systems installed within containers

Containers housing PSA hydrogen systems shall be mechanically ventilated. Failure of ventilation, confirmed by measurement of flow, pressure, or the current of the ventilating device, shall trigger an audible or visible alarm and may trigger a PSA hydrogen system shutdown. In systems intended for outdoor use, containers may be positive pressure ventilated as per IEC 60079-2 or other applicable code or regulation. The maximum concentration of any flammable gas in the system ventilation exhaust should be below 25 % of the LFL during all operation conditions.

5.2.4 Explosion-proof area and explosion-proof grade

Classification of all areas associated with the hydrogen PSA system that have an explosion hazard shall comply with IEC 60079-10-1 or other applicable local regulations.

Outdoor areas near PSA equipment and well-ventilated areas inside buildings shall be classified based on the potential for hydrogen to be present due to leaks or other breakdown (e.g. Zone 2 per IEC 60079-10-1).

The explosion-proof grade of electrical equipment should not be lower than the grade and group of explosive hydrogen mixture: IIC T1.

Electrical equipment and wiring in areas with explosion hazard shall be selected and configured in accordance with IEC 60079-0 and IEC 60079-14 or other applicable local code or regulations.

5.2.5 Electrostatic grounding

5.2.5.1 General

Electrostatic grounding shall be carried out for the objects that can result in electrostatic hazard because the PSA system for hydrogen separation and purification may generate and accumulate static electricity. Dedicated electrostatic grounding connectors shall have a resistance to ground according to the requirements of IEC 60204-1, IEC 60364-4 or applicable local code or regulations. When other grounding devices are used for electrostatic grounding, their grounding resistances shall be selected based on applicable local code or regulations covering such grounding devices.

5.2.5.2 Adsorber and buffer tank

Enclosures of adsorber, buffer tank and other stationary pressure vessels shall be subject to electrostatic grounding. Equipment with diameter of not less than 2,5 m and volume of not less than 50 m³ should have at least two grounding points and the grounding points should be evenly distributed along the periphery of the equipment with an interval of not more than 30 m.

5.2.5.3 Piping system

Electrostatic grounding should be provided at the inlet and outlet of the unit, at the boundary of areas with different explosion hazards, at pipe branches, and every 80 m to 100 m along straight pipes. When the net distance between parallel pipes is less than 100 mm, jumpers should be provided every 20 m to prevent a spark jumping from one pipe to another. When the distance between two pipes that cross each other is less than 100 mm, a jumper should be provided where the pipes cross.

Metal flanges fastened with metal bolts or clamps are usually not provided with additional electrostatic wire, but it is required to ensure good conductive contact between four bolts or clamps at a minimum.

5.2.6 Flammable and toxic gas detection alarm

Combustible gas detectors shall be installed in unit areas. When toxic gas exists and may result in injuries to personnel if leaks form, toxic gas detector(s) shall be installed.

The monitoring points should be located at such places where gas tends to accumulate and sampling and detection can be carried out easily in accordance with physical and chemical properties of gases, features of release source, layout of production area, geographical conditions, environment and climate, operation and inspection routes, etc.

Some of the places where combustible or toxic gas leakage or accumulation may occur:

- seals of vacuum pumps or compressors;
- gas sampling ports and associated analysers;
- drains and vents;
- equipment or piping flanges;
- valve packing;
- buildings or containers associated with the PSA system.

When combustible gas in the air is 25 % of its lower explosive limit, or when the toxic gas concentration reaches 25 % of the permissible exposure limit, audible and visual detection alarm shall be activated at site. In addition, the alarm signal shall be sent to the control room or operation room.

The number of flammable and toxic gas monitoring points should depend on the location of possible release sources and the ventilation conditions.

5.3 Safety specifications of equipment and piping

5.3.1 General specification

Adsorbers are the primary components of the PSA system for hydrogen separation and purification, and their performance determines the performance of the PSA system. The vessel dimensions, internal component design, and adsorbent selection and amount are chosen to optimize hydrogen recovery rate and manufacturing cost, to prevent adsorbent leakage and particle fluidization, and to ensure mechanical strength within the design life cycle.

5.3.2 Safety specifications of adsorbers

5.3.2.1 General

Individual adsorbers of hydrogen PSA systems are in cyclic service and will typically withstand about 1 million cycles after 10 to 20 years of operation. So fatigue is an important mode of failure to be considered, aggravated by the presence of hydrogen.

An adsorber is designed for a given pressure and number of cycles, and especially all assemblies are designed according to the corresponding S-N curve, as weld joints are primarily areas of crack initiation due to fatigue.

The main parameters that affect fatigue resistance of adsorbers, except intrinsic stress variation for PSA process, are the effect of exposure to hydrogen (called hydrogen embrittlement), weld quality, and fabrication quality (e.g. peaking, misalignment, and corrosion fatigue).

5.3.2.2 Hydrogen embrittlement

The susceptibility to hydrogen embrittlement is strongly dependent on the materials' strength properties and hydrogen environment.

Gaseous hydrogen embrittlement generally occurs at close to ambient temperatures for carbon steel. In combination with the cyclic fatigue mechanism through fluctuating bending stresses (i.e. pressures) in the PSA system with the presence of atomic hydrogen in dislocations causes accelerated crack growth.

The greater the hydrogen purity, the more pronounced the embrittling effect since the impurities most frequently encountered in hydrogen (i.e. traces of oxygen and water vapour) have an inhibiting effect on embrittlement. Sulfur dioxide and carbon monoxide also have an inhibiting effect. Other impurities (e.g. methane, nitrogen) do not seem to have any appreciable effect. Some impurities (e.g. carbon dioxide and especially hydrogen sulfide) have an accelerating effect on hydrogen embrittlement.

The parameters that should be considered related to hydrogen embrittlement are the environment (i.e. operating conditions), the design, and surface condition and the materials. As hydrogen embrittlement is similar to a stress corrosion phenomenon, the stress level is of paramount importance. All forms of stresses (e.g. thermal, pressure, mechanical, etc.) should be considered in a hydrogen PSA system.

5.3.2.3 Geometric discontinuities (peaking)

Geometric discontinuities are also important as they can create high local stress that will reduce significantly the fatigue lifetime of the vessel. Geometric discontinuities include those created by manufacturing tolerances (e.g. misalignment, peaking, out of roundness) which are here much more critical than for a static vessel.

Peaking is a deviation from a true circular shape located along a longitudinal weld of a shell.

Taking peaking into account requires measuring the distance "delta" to theoretical circle (outside = "roof" shape or inside = "heart" shape).

For defining the maximum acceptable peaking size, pressure vessel codes, such as ISO 16528-1 or local applicable code or regulations, should be consulted.

5.3.2.4 Corrosion

Under some conditions in a hydrogen PSA system, adsorbers could be affected by internal corrosion in case of the presence of condensate in the bottom head, even in the presence of hydrogen.

In the presence of corrosion and pressure cycling conditions, a crack could be initiated at corrosion pit and could be propagated by fatigue.

5.3.2.5 Design and manufacture

The design and manufacture of the adsorber should comply with the appropriate local and national pressure vessel regulations, and consideration shall be given to the impact of alternating stress. If not, there is chance of failure or damage in the vessels because of accumulation of plastic strain.

The welding of any plate on the adsorbers should be minimized, and when performed, the effect on the alternating stress should be evaluated.

Gaskets should be selected to prevent leakage from the adsorber vessels during normal operation and to withstand the change in conditions during startup and shutdown.

5.3.3 Safety specifications of the buffer tank

The manufacture of the buffer tank should conform to the requirements of ISO 16528-1 or to local regulations.

In cases where buffer tanks with different operating pressures are connected, the buffer tank with the lowest operating pressure shall not be operated at overpressure under any condition. Buffer tanks should be located such that there is no direct impact on adjacent tanks in the event of leakage from the buffer tank(s).

A separate safety system should be installed for each buffer tank if it is possible to isolate them or if their design pressures differ. If there is no potential for the buffer tanks to be isolated from each other, a single safety system may be used if the design pressure of the vessels is identical or if the safety system is designed to maintain the pressure below the lowest buffer tank design pressure.

5.3.4 Safety specifications of process control valves

Process control valves act frequently. The failure of process control valves may result in whole system malfunction, adsorbents damage, or equipment overpressure. During the PSA design phase, consideration should be given to selecting control valves that will have minimal leakage over the life of the valve.

5.3.5 Safety specifications of piping

5.3.5.1 General specification

Materials for pipe and pipe fittings of the PSA system for hydrogen separation and purification should be selected in accordance with the requirements set forth in the appropriate local and national pressure piping specifications.

5.3.5.2 Piping design

In the design of piping directly connected to the adsorbers, for example, the piping between adsorbers and process control valves, consideration should be given to the impact of alternating stress (caused by the frequent pressure change) on the pipe strength.

Pipe sections under thermal expansion and contraction should be designed and laid out based on flexibility calculations and thermal compensation requirements.

The piping system should be equipped with nitrogen purging facilities.

Pipe supports should be designed and located in accordance with the requirements set forth in the appropriate local and national pressure piping regulations.

5.3.5.3 Safety relief devices

If the design pressure of the PSA system piping or vessels is less than the upstream or downstream design pressure or if the PSA system is subject to a fire or other thermal relief case, relief valves may be required to protect the PSA system equipment. Common locations for relief valves are downstream of the feed stream inlet shut-off valves and on the buffer tank(s) (see [Figure A.1](#)). Any relief valves shall comply with ISO 4126-1 or other applicable local code or regulations.

5.3.6 Safety considerations for operations and maintenance

Because hydrogen PSA systems contain flammable and/or toxic gas during normal operation, thorough purging of the PSA system prior to maintenance and before returning the system to service is essential. For this reason, hydrogen PSA systems shall be designed with sufficient vents to enable purging of the PSA system. Dead legs should be minimized since pockets of trapped gas can be difficult to remove.

Consideration should be given on the direction in which gas will flow. Purging is typically conducted in a top-down direction to avoid migration of water from the lower layer(s) of adsorbent onto the upper layer(s).

Hydrogen PSA systems are typically purged with nitrogen. The PSA system design should include connections to enable flow of nitrogen into the piping and vessels. PSA system designs should include connections at the appropriate locations to facilitate nitrogen purging during adsorbent removal.

If any portion of the PSA system being purged is located indoors, precautions shall be taken during purging and when checking oxygen or flammable gas levels to prevent flammable gas build up or oxygen deficient condition within the building or enclosure.

Prior to maintenance, purging shall reduce the flammable gas concentration to less than 25 % of the LEL according to NFPA 56 or to the level prescribed by local code or regulations. Before placing the PSA system in operation, the oxygen level shall be reduced to 60 % of the minimum oxygen (limiting oxidant) concentration required to support combustion.

There is a particular risk of air ingress into the feed stream when operating the PSA system at sub-atmospheric pressures.

5.3.7 Safety specifications of inspection and test

5.3.7.1 Non-destructive testing

100 % non-destructive testing should be applied to welds of the piping where connected to adsorber vessels because those welds are subjected to cyclic stress. The testing method should accord with ISO 17636-1 or local requirements.

The grade of welding should be in accordance with ISO 5817, ISO 3834-1, ISO 3834-2 or related local regulations.

5.3.7.2 Principle of pressure testing

Hydraulic testing is preferred for piping pressure tests. When pneumatic pressure testing is used on piping, test procedure and appropriate safety measures should be taken as required by ISO 15649 or local requirements.

When pressure testing a section of piping that contains instrumentation, the test pressure shall not exceed the maximum allowable test pressure of the instruments unless the instruments are removed.

When the design temperature of the piping surpasses the test temperature, the test pressure should be calculated based on applicable local or national regulations.

5.3.7.3 Pressure test

5.3.7.3.1 Preparations before test

Various certificates of conformity and technical documents, including all test records and certificates, drawings, inspection certificates for the adsorber vessels and buffer tanks, should be checked for completeness prior to the pressure test, and the test should be carried out only after the aforesaid certificates and documents are verified to be correct.

Visual inspection should be conducted after assembly of the PSA system is completed to check the relevant dimensions of the system, to verify the correct connections of the various piping and electrical circuits and to evaluate the general appearance of the system.

5.3.7.3.2 Strength test

The PSA system for hydrogen separation and purification should be tested according to the local and national vessel and piping codes. Testing of individual components shall be acceptable, with connection joints being subject to ISO 5817 or the appropriate pressure vessel code requirements.

5.3.7.3.3 Vacuum test

After the strength test, vacuum systems should be subject to vacuum for 24 h. The air tightness and degree of vacuum should be in accordance with local code or regulations.

5.3.7.3.4 Container ventilation testing

Ventilation systems of containers or buildings that house hydrogen PSA systems shall be tested to verify that they conform to local code or regulations. The hourly air exchange rate with the exhaust fan in operation should be verified. To verify the effectiveness of the ventilation, the flammable or toxic gas sensor should be located based on where the gas will accumulate.

If the electric equipment and wires of the electrical container are not explosion proof, the electrical container should undergo a pressure test at 1,0 kPa and should be considered qualified if there is no leakage.

5.3.8 Safety specifications of electrical equipment

Electrical facilities in hydrogen generation areas should be protected in accordance with IEC 60079-10-1 or other applicable local or national electrical code. Outdoor areas and areas within well-ventilated buildings should be classified based on the potential for hydrogen to be present due to leaks or other breakdown (e.g. Zone 2 per IEC 60079-10-1). Electrical equipment and associated wiring in areas with explosion hazards should be selected and configured in accordance with IEC 60079-0 and IEC 60079-14 or other applicable local or national electrical code.

All metal enclosures, piping, bases, or frames should be grounded and comply with IEC 60204-1 and IEC 60364-4 or other applicable local or national electrical code.

5.3.9 Safety specifications of monitoring devices

5.3.9.1 General specification

Key parameters during operation should be continuously monitored. In case of a failure, the monitoring system should initiate alarms and/or shutdown interlocks. Instrumentation design and specifications should comply with the requirements of IEC 61508 or other applicable local regulations or code.

5.3.9.2 Monitoring devices

5.3.9.2.1 Pressure measuring instruments

Pressure monitoring data provide the main basis for the control system to determine the operational status of the PSA system. These instruments monitor the pressure during adsorption and desorption to ensure proper operation and to identify equipment failure. Pressure of the following items may be monitored: feed gas, adsorbers, hydrogen product, buffer tank(s), instrument air, etc.

Overpressure may appear in a PSA hydrogen system under the following conditions:

- open-close valves between vessels at different operational pressure level fail to close;
- modulating control valve fails to open or close or moves to an incorrect position;
- PSA system outlet block valves are closed, and the feed to the PSA is supplied by a compressor.

5.3.9.2.2 Temperature measuring instruments

Temperature measurements are used to correct the computation of feed gas and product hydrogen flow rate and may be used to monitor or control the adsorption process during operation.

5.3.9.2.3 Gas composition analysis instruments

To ensure that the oxygen level does not result in a flammable or explosive mixture, online oxygen analysis should be provided on the feed gas and desorbed gas piping of hydrogen PSA systems if the feed can contain enough oxygen to result in a hazardous mixture in either the feed or desorbed gas stream.

5.3.9.2.4 Valve position sensor

Process control valves may be provided with a valve position sensor that sends the valve position to the control system to prevent a high-pressure stream from leaking into a low-pressure stream. For open/close valves, the position sensor is a switch that indicates if the valve is in a given position (open or closed).

5.3.9.3 Automatic interlock shutdown control system

If one of the monitoring devices of a PSA system for hydrogen separation and purification sends out an alarm signal, an investigation should be carried out. The cause of the alarm should be identified and the issue resolved such that normal operation is resumed.

In order to maintain safe operation of the PSA system, it may be shut down for inspection if one of the following conditions occurs.

- pressure, temperature, compositions or flow rate of feed gas exceeds the alarm set point;
- a process control valve fails during operation or internal valve leakage occurs and cannot be isolated;
- the hydrogen concentration in the air exceeds 1 %;
- power supply of the PSA system fails;

- the pressure of the instrument air reaches its interlock value;
- oxygen content in a feed stream or in piping with the vacuum desorption process exceeds the permissible limit;
- pressure of buffer tank exceeds the maximum allowable set point;
- vessel or piping leaks to the atmosphere;
- toxic gas concentration in the air exceeds the allowable value.

A hazard review should be conducted to identify the alarms and interlocks that are required to provide safe operation of the PSA system.

Other failures in the PSA system or in upstream or downstream operating units may also necessitate the shutdown of the PSA system.

Annex A (informative)

Example of potential locations of relief valves

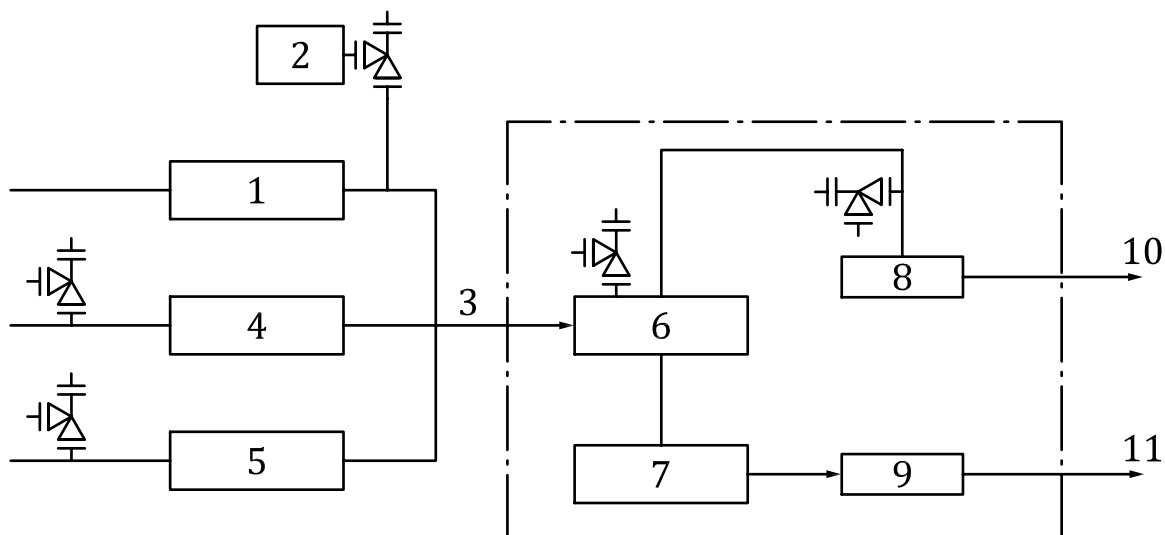

Key

- | | |
|---|---------------|
| 1 inlet shut-off valve | 7 vacuum pump |
| 2 relief valve | 8 buffer tank |
| 3 feed gas | 9 surge drums |
| 4 outlet shut-off valve of gas-liquid separator | 10 product |
| 5 feed gas buffer | 11 tail gas |
| 6 adsorbers | |

Figure A.1 — Potential locations of relief valves

Bibliography

- [1] ISO 3834-1, *Quality requirements for fusion welding of metallic materials — Part 1: Criteria for the selection of the appropriate level of quality requirements*
- [2] ISO 3834-2, *Quality requirements for fusion welding of metallic materials — Part 2: Comprehensive quality requirements*
- [3] ISO 5817, *Welding — Fusion-welded joints in steel, nickel, titanium and their alloys (beam welding excluded) — Quality levels for imperfections*
- [4] ISO 15649, *Petroleum and natural gas industries — Piping*
- [5] ISO/TR 15916, *Basic considerations for the safety of hydrogen systems*
- [6] ISO 16110-1, *Hydrogen generators using fuel processing technologies — Part 1: Safety*
- [7] ISO 16528-1, *Boilers and pressure vessels — Part 1: Performance requirements*
- [8] ISO 17636-1, *Non-destructive testing of welds — Radiographic testing — Part 1: X- and gamma-ray techniques with film*
- [9] IEC 60079-2, *Explosive atmospheres — Part 2: Equipment protection by pressurized enclosure “p”*
- [10] IEC 61508, *Functional safety of electrical/electronic/programmable electronic safety-related systems*

