

---

---

**Transport packaging — Small load  
container systems —**

Part 2:  
**Column Stackable System (CSS)**

*Emballage — Systèmes de transport de petites charges —  
Partie 2: Systèmes gerbable en colonnes (SGP)*



**COPYRIGHT PROTECTED DOCUMENT**

© ISO 2016, Published in Switzerland

All rights reserved. Unless otherwise specified, no part of this publication may be reproduced or utilized otherwise in any form or by any means, electronic or mechanical, including photocopying, or posting on the internet or an intranet, without prior written permission. Permission can be requested from either ISO at the address below or ISO's member body in the country of the requester.

ISO copyright office  
Ch. de Blandonnet 8 • CP 401  
CH-1214 Vernier, Geneva, Switzerland  
Tel. +41 22 749 01 11  
Fax +41 22 749 09 47  
copyright@iso.org  
www.iso.org

# Contents

Page

<b>Foreword</b> .....	<b>iv</b>
<b>Introduction</b> .....	<b>v</b>
<b>1 Scope</b> .....	<b>1</b>
<b>2 Normative references</b> .....	<b>1</b>
<b>3 Terms and definitions</b> .....	<b>1</b>
<b>4 Characteristics</b> .....	<b>2</b>
<b>5 Dimensions, masses and applied loads</b> .....	<b>2</b>
5.1 CSS SLC .....	2
5.1.1 Main dimensions and tolerances .....	2
5.1.2 Detailed dimensions for CSS SLCs .....	3
5.2 Accessories .....	6
<b>6 Essential functional features</b> .....	<b>11</b>
6.1 CSS SLC .....	11
6.2 Carrying handles .....	12
6.3 Vertical ribs for lifting grippers .....	13
6.4 Centering holes .....	14
6.5 CSS-SLC base .....	14
<b>7 Material</b> .....	<b>14</b>
<b>8 Marking and labelling</b> .....	<b>14</b>
<b>Annex A (informative) Column stacking of palletized loads</b> .....	<b>15</b>
<b>Annex B (informative) Colours</b> .....	<b>17</b>

## Foreword

ISO (the International Organization for Standardization) is a worldwide federation of national standards bodies (ISO member bodies). The work of preparing International Standards is normally carried out through ISO technical committees. Each member body interested in a subject for which a technical committee has been established has the right to be represented on that committee. International organizations, governmental and non-governmental, in liaison with ISO, also take part in the work. ISO collaborates closely with the International Electrotechnical Commission (IEC) on all matters of electrotechnical standardization.

The procedures used to develop this document and those intended for its further maintenance are described in the ISO/IEC Directives, Part 1. In particular the different approval criteria needed for the different types of ISO documents should be noted. This document was drafted in accordance with the editorial rules of the ISO/IEC Directives, Part 2 (see [www.iso.org/directives](http://www.iso.org/directives)).

Attention is drawn to the possibility that some of the elements of this document may be the subject of patent rights. ISO shall not be held responsible for identifying any or all such patent rights. Details of any patent rights identified during the development of the document will be in the Introduction and/or on the ISO list of patent declarations received (see [www.iso.org/patents](http://www.iso.org/patents)).

Any trade name used in this document is information given for the convenience of users and does not constitute an endorsement.

For an explanation on the meaning of ISO specific terms and expressions related to conformity assessment, as well as information about ISO's adherence to the WTO principles in the Technical Barriers to Trade (TBT) see the following URL: [Foreword - Supplementary information](#)

The committee responsible for this document is ISO/TC 122, *Packaging*.

ISO 19709 consists of the following parts, under the general title *Transport packaging — Small load container systems*:

- *Part 1: Common requirements and test methods*
- *Part 2: Column Stackable System (CSS)* [Technical Specification]
- *Part 3: Bond Stackable System (BSS)* [Technical Specification]

## Introduction

The small load container (SLC) system specified in this part of ISO 19709 was first conceived for handling, storage and transport of goods and designed to meet the needs of automotive manufacturers and their suppliers.

The multi-functional design of its elements allow a SLC system manufactured in accordance with ISO 19709 to meet the requirements of different manual, mechanical and automatic handling, transport and storage systems in the automotive industry transportation chain. It is likely that this system of SLCs and accessories will frequently be used in a pool.

The special characteristic of the system specified in ISO 19709 is the self-securing mechanism of the unit load in the column stack. For this reason, this system is called column stackable system.

The CS system consists of the following elements:

- CSS-SLC;
- Lid [the prefix “D” reflects the German term for “lid” (Deckel)];
- Pallet cover [the prefix “A” reflects the German term for “cover” (Abdeckung)].

The use of CSS-SLC systems with palletized loads is discussed in [Annex A](#).



# Transport packaging — Small load container systems —

## Part 2: Column Stackable System (CSS)

### 1 Scope

This part of ISO 19709 specifies the main characteristics and the testing of durable, reusable, parallelepipedic containers and their accessories which form a column stackable system (CSS) designed to contain bulk or precisely located component loads up to maximum load of 20 kg used for automotive industry applications.

### 2 Normative references

The following documents, in whole or in part, are normatively referenced in this document and are indispensable for its application. For dated references, only the edition cited applies. For undated references, the latest edition of the referenced document (including any amendments) applies.

ISO 19709-1:—<sup>1)</sup>, *Transport packaging — Small load container systems — Part 1: Common requirements and test methods*

### 3 Terms and definitions

For the purposes of this document, the terms and definitions given in ISO 19709-1 and the following apply.

#### 3.1

##### **CSS small load container**

small load container (SLC) with special functional features which ensure a mutual compatibility

#### 3.2

##### **pallet cover**

system element with a safeguarding and protective function that closes the top of the loading unit with a level surface that distributes the mass of overlying loads in a stack

#### 3.3

##### **SLC capacity**

usable inner volume which is calculated by multiplying the usable inner length by the usable inner width (both measured at half height) and the usable inner height

#### 3.4

##### **SLC lid (D 65, D 45, D 35)**

BSS-SLC and CSS-SLC system elements with virtually neutral height for protection of the cargo

Note 1 to entry: The prefix “D” reflects the German term for “lid” (Deckel).

Note 2 to entry: The number 65 means lid for the 600 mm × 400 mm size containers. The number 45 means lid for the 400 mm × 300 mm size containers. The number 35 means lid for the 300 mm × 200 mm size containers.

#### 3.5

##### **SLC unit load**

load consisting of a SLC which forms a unit for handling, transport, stacking and storage

---

1) To be published.

## 4 Characteristics

The heights of CSS SLCs are determined in such a way that when used in combination with a 150 mm high pallet and a cover they form a nominal unit load height of 1 000 mm (see [Annex A](#)).

The column stackable system is characterized by the following features:

- a) maximum load: 20 kg;
- b) “load space” and “functional space for handling” are clearly separated;
- c) smooth, flat internal SLC surfaces without undercuts permit rapid, reliable manual removal of the contents and mechanical/automatic filling and emptying;
- d) functional features, see [Clause 6](#).

## 5 Dimensions, masses and applied loads

### 5.1 CSS SLC

#### 5.1.1 Main dimensions and tolerances

When tested in accordance with ISO 19709-1:—, Annex A, A.2.1, A.2.2 and A.2.4, the main dimensions of the CSS SLC shall be as given in [Table 1](#).

The flange height shall be 15 mm (see [Figure 1](#)).

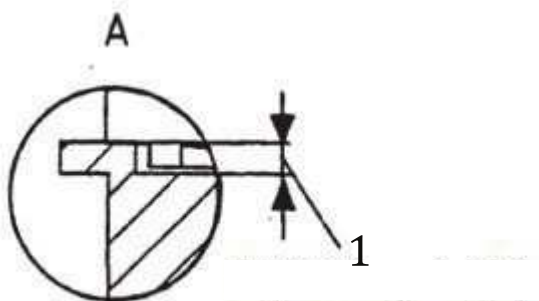

#### Key

- 1 height  $\geq$  flange height

**Figure 1 — Flange height**

The stacking clearance shall ensure easy location when two CSS SLCs are stacked. The stacking clearance in length and width of two CSS SLCs may not exceed 4,8 mm.

To ensure the functioning of the CSS, the overall height of an individual CSS SLC shall be 147,5 mm or 280 mm.

NOTE For the area base module of 300 mm  $\times$  200 mm only, the height ratios of 147,5 mm is applicable.



Table 1 — Main dimensions of CSS SLCs

Dimensions in millimetres

Type	Nominal dimension L × W × H	Length			Width			Height			Tolerance
		outer	inner	tolerance	outer	Inner	tolerance	total	inner	usable inner height <i>F</i>	
6 280	600 × 400 × 280	594	539,5	0 -4,8	396	357,5	0 -3,2	280	277	262 <sup>a</sup> 252 <sup>b</sup>	±1
6 213	600 × 400 × 213							213	210	195,8 <sup>a</sup> 185,8 <sup>b</sup>	
6 147	600 × 400 × 147							147,5	144,5	129,5 <sup>a</sup> 119,5 <sup>b</sup>	
4 280	400 × 300 × 280	396	342,5	0 -3,2	297	247	0 -2,4	280	277	262 <sup>a</sup> 254 <sup>b</sup>	±1
4 213	400 × 300 × 213							213	210	195,8 <sup>a</sup> 185,8 <sup>b</sup>	
4 147	400 × 300 × 147							147,5	144,5	129,5 <sup>a</sup> 121,5 <sup>b</sup>	
3 147	300 × 200 × 147	297	241,5	0 -2,4	198			147,5	144,5	129,5 <sup>a,b</sup>	±1
<sup>a</sup> value without lid. <sup>b</sup> value with lid.											

When tested in accordance with ISO 19709-1:—, Annex A, A.2.1, A.2.2 and A.2.4, volumes and masses of CSS SLC shall be as given in [Table 2](#).

Table 2 — Volumes and masses of CSS SLCs

Type	Volume dm <sup>3</sup>		Tare mass ±1 % kg	Nominal load kg	Nominal stacking load kg
	outer	usable inner (capacity)			
6 280	65	51,9	2,67	20	600
6 213	51	38,9	2,27		
6 147	35	25	1,82		
4 280	33	24,1	1,70		
4 213	25,5	17,9	1,42		
4 147	17	11,8	1,08		
3 147	8,7	5,3	0,57	20	400

### 5.1.2 Detailed dimensions for CSS SLCs

Detailed dimensions for CSS SLC shall be as given in [Figures 2, 3 and 4](#).

Dimensions in millimetres

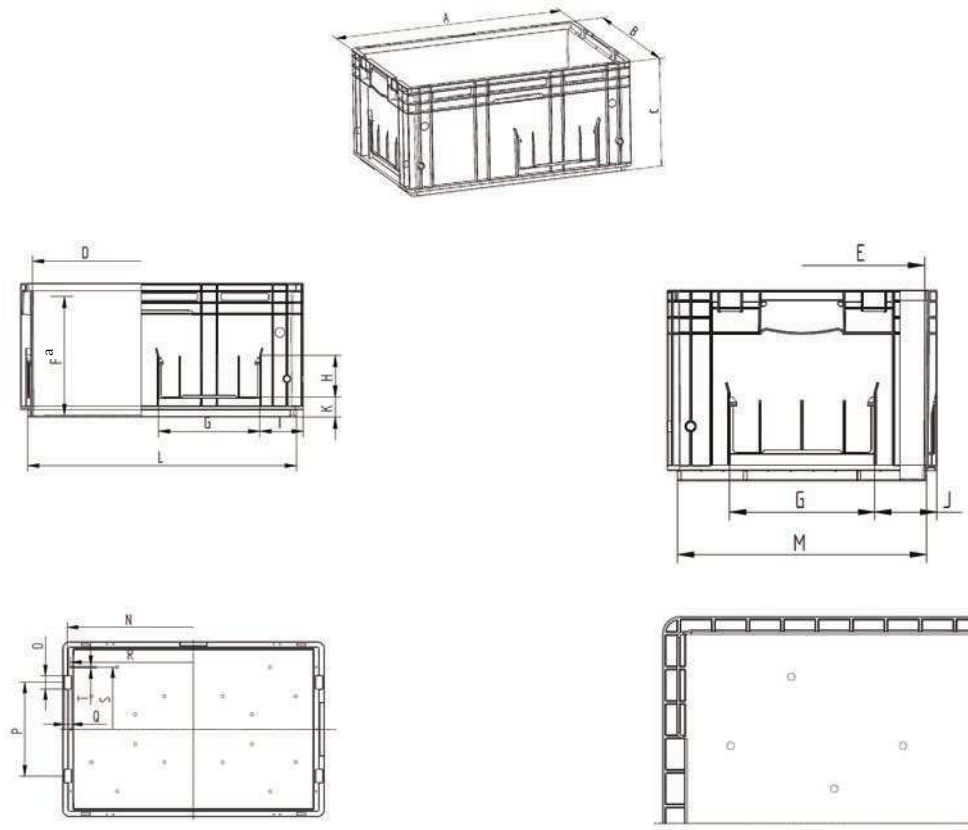

**Key**

a Usable inner height.

SLC type	A	B	C	D	E	F	G	H	I	J	K	L	M	N	O	P	Q	R	S	T
6 147	594	396	147,5	539,5	357,5	119,5	212	82	92	92	65,5	563	366	567	30	210	15	556	280	Ø4
6 422	594	396	213	539,5	357,5	185,8	212	82	92	92	41,5	563	366	567	30	210	15	556	280	Ø4
6 280	594	396	280	539,5	357,5	252	212	82	92	92	41,5	563	366	567	30	210	15	556	280	Ø4

**Figure 2 — CSS SLC type 6147 and CSS SLC type 6280**

Dimensions in millimetres

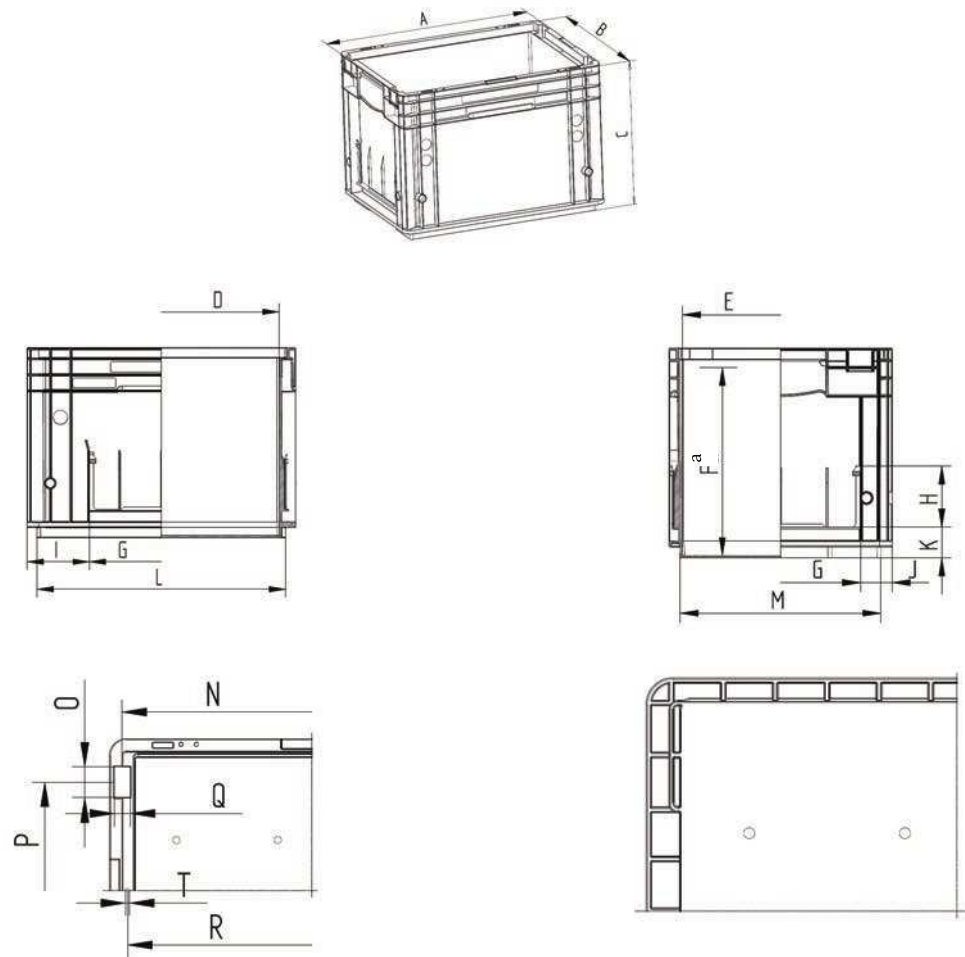

**Key**

a Usable inner height.

SLC type	A	B	C	D	E	F	G	H	I	J	K	L	M	N	O	P	Q	R	T
4 147	396	297	147,5	342,5	258	121,5	212	82	92	42,5	65,5	365	266	370	30	210	15	358	Ø4
4 213	396	297	213	342,5	258	185,8	212	82	92	42,5	41,5	365	266	370	30	210	15	358	Ø4
4 280	396	297	280	342,5	258	254	212	82	92	42,5	41,5	365	266	370	30	210	15	358	Ø4

**Figure 3 — CSS SLC type 4147 and CSS SLC type 4280**

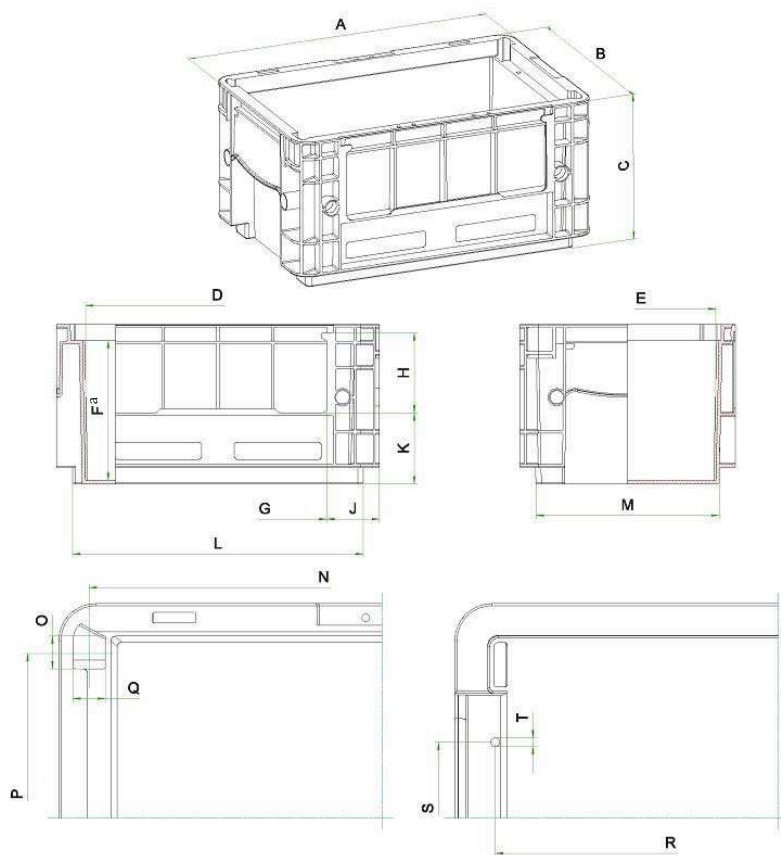

**Key**

a Usable inner height.

SLC type	A	B	C	D	E	F	G	H	J	K	L	M	N	O	P	Q	R	S	T
3 147	297	198	147,5	241,5	161,5	129,5	212	82	42,5	65,5	267	168	269	15	153	15	260	70	Ø4

**Figure 4 — CSS SLC type 3147**

**5.2 Accessories**

The essential dimensions of CSS SLC accessories shall be as given in [Table 3](#).

The detailed dimensions for accessories shall be as given in [Figures 5 to 9](#).

NOTE 1 CSS SLCs can be used with or without accessories. Their use is a matter for agreement between the partners in the transportation chain.

NOTE 2 If lids are used, the usable inner height of CSS SLCs differs (see [Table 1](#)).

NOTE 3 The main functions of lids are to protect the SLC contents against environmental impacts and when sealed, against unauthorized access. When lids are fitted, they do not increase the CSS SLC stacking height.

NOTE 4 Pallet cover protects the CSS SLC unit loads against water and dust, provides a stacking location for the upper pallet and act as clasps to retain column stacked CSS SLCs.

**Table 3 — Essential dimensions for CSS-SLC accessories**

Dimensions in millimetres

Name of the element	Type	Nominal dimension L × B × H	Length			Width			Height ±1 %	Mass kg ±1 %
			outer	inner	tolerance	outer	inner	tolerance		
Lid	D 65	600 ×400× 16	562,5	—	0 -2,8	365	—	0 -1,8	16 13,5	0,67
	D 45	400 ×300× 13,5	365	—	0 -1,8	267	—	0 -1,45		0,27
	D 35	300 ×200× 17	267,8	—	0 -1,45	169,6	—	0 -0,9	17	0,09
Pallet cover	A 1208	1 200 ×800× 25	1 204	1 197	+9,6 0	808	800	+6,4 0	94	6,1
	A 1210	1 200× 1000	1 205,5	1 196	+9,6 0	1 007,5	998	+8 0	67,7	9,35

EXAMPLE D 65 means lid for 600 mm × 400 mm containers. A 1210 means cover for 1 200 mm × 1 000 mm pallets.

Dimensions in millimetres

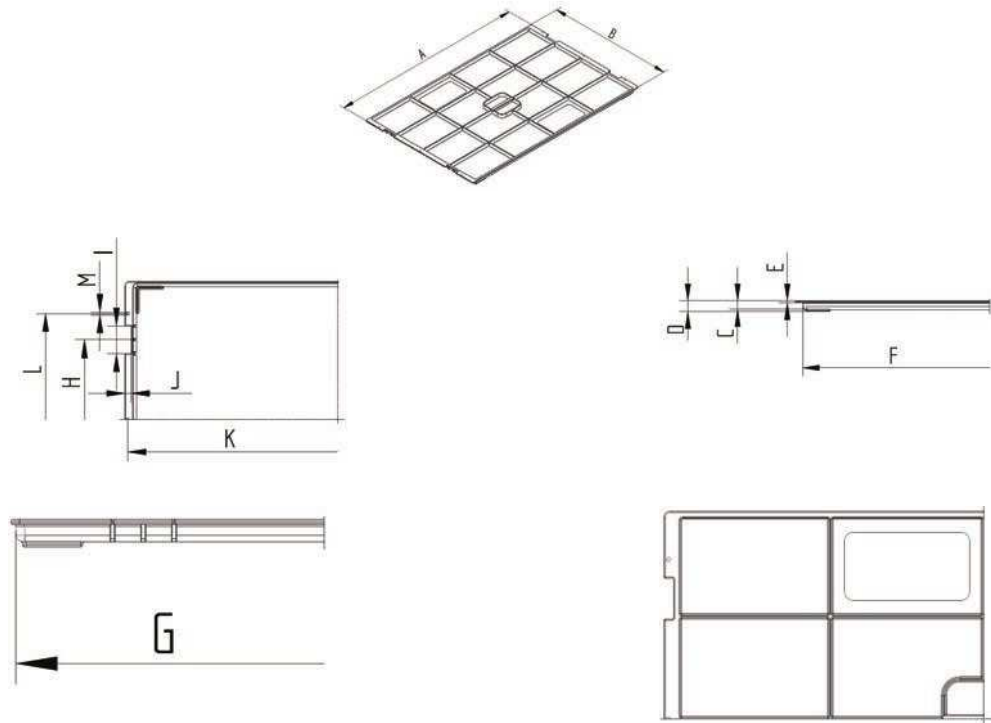

Lid	A	B	C	D	E	F	G	H	I	J	K	L	M
D 65	562,5	365	13	16	3	541,5	359	210	36	8,5	555	280	Ø3,5

**Figure 5 — Lid D 65**

Dimensions in millimetres

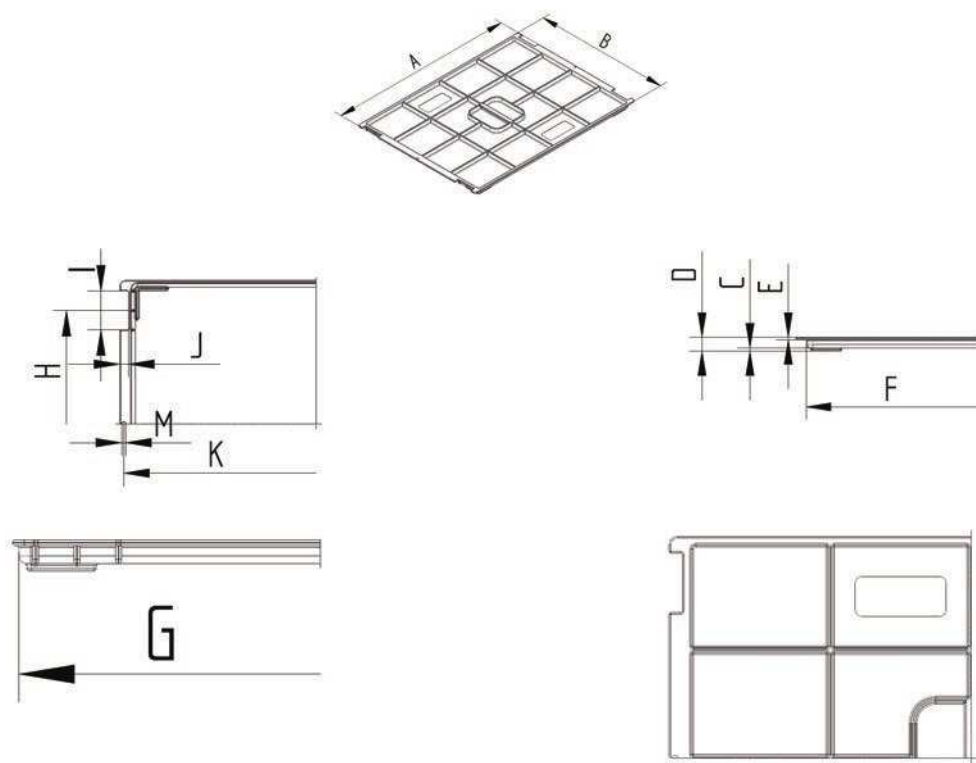

Lid	A	B	C	D	E	F	G	H	I	J	K	L	M
D 45	365	267	10,5	13,5	3	344,8	261,3	211	36	8	358	-	Ø3,5

Figure 6 — Lid D 45

Dimensions in millimetres

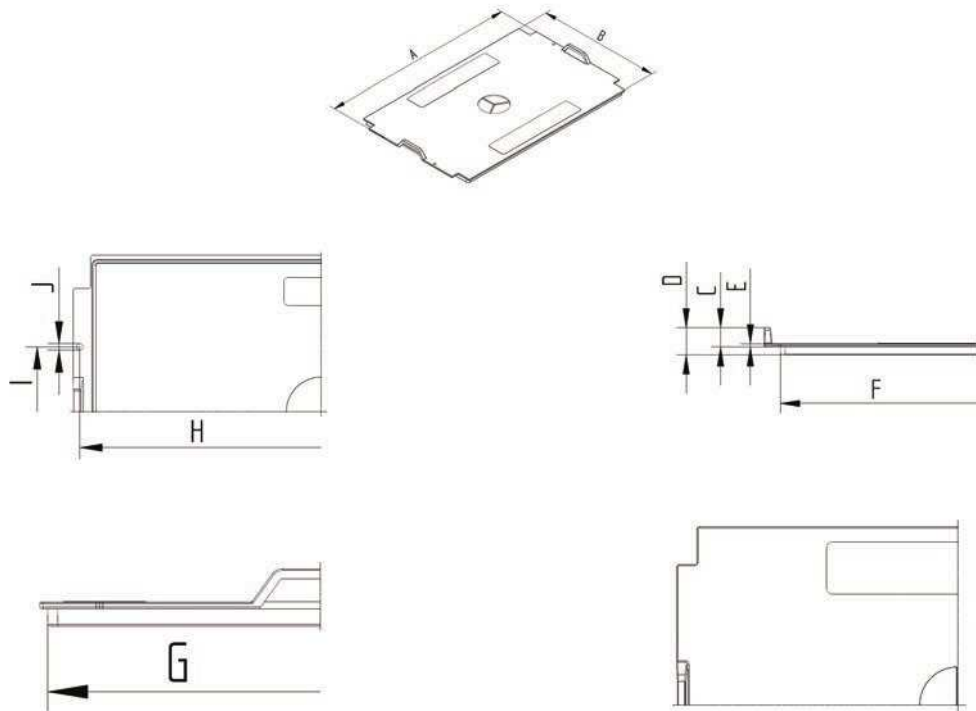

Lid	<i>A</i>	<i>B</i>	<i>C</i>	<i>D</i>	<i>E</i>	<i>F</i>	<i>G</i>	<i>H</i>	<i>I</i>	<i>J</i>
D 35	267,8	169,6	12	17	2	246,7	164,3	260	70	Ø3,5

Figure 7 — Lid D 35

Dimensions in millimetres

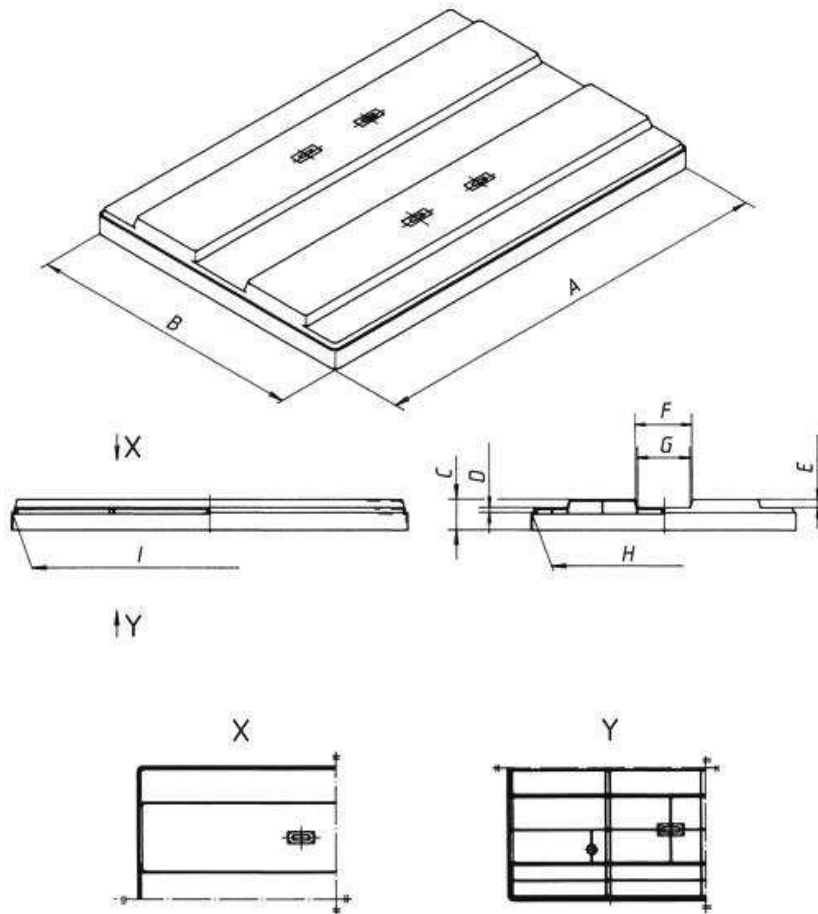

Pallet cover	<i>A</i>	<i>B</i>	<i>C</i>	<i>D</i>	<i>E</i>	<i>F</i>	<i>G</i>	<i>H</i>	<i>I</i>
A 1208	1 204	808	94	15	25	590	160	800	1 196

Figure 8 — Pallet cover A 1208



Dimensions in millimetres

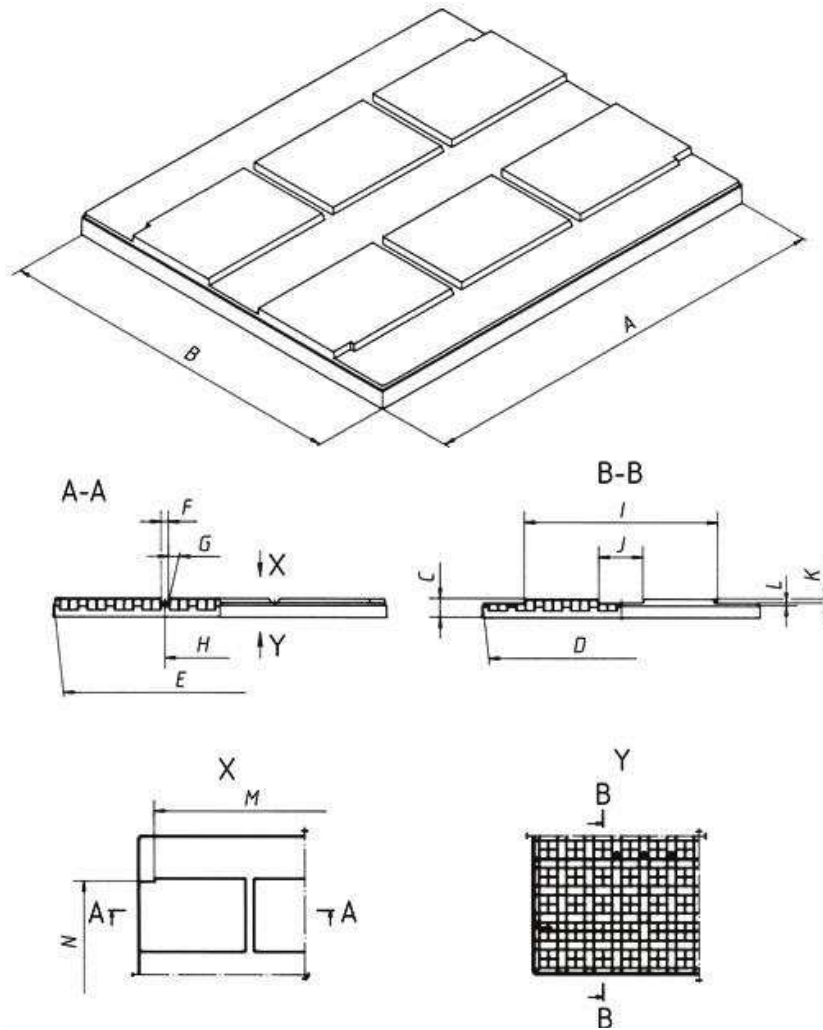

Pallet cover	A	B	C	D	E	F	G	H	I	J	K	L	M	N
A 1210	1 205,5	1 007,5	67,7	998	1 196	27	15	396	700	160	15	10	1 086	676

Figure 9 — Pallet cover A 1210

## 6 Essential functional features

### 6.1 CSS SLC

Functional features of the CSS SLC shall be as illustrated in [Figure 10](#).

NOTE For detailed explanations, see [Figures 10](#) to [14](#).

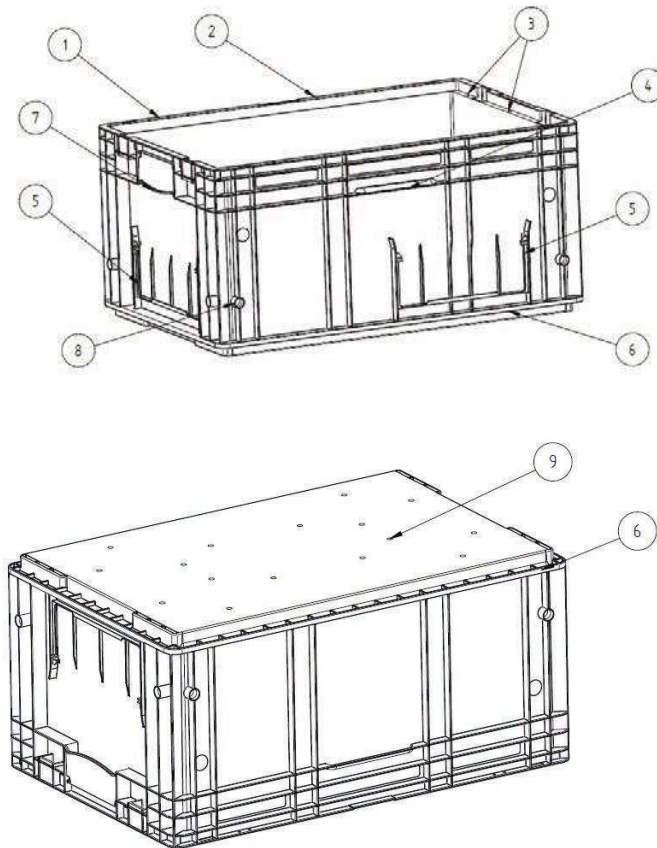

**Key**

- 1 security sealing holes
- 2 upper stacking rim
- 3 lid securing holes
- 4 auxiliary handles (only for CSS SLC 6 280 and CSS SLC 4 280)
- 5 label holder (1/4 A4 size in accordance with ISO 216)
- 6 lower stacking rim
- 7 main handle
- 8 centering hole
- 9 drainage holes (not for CSS SLC 3 147)

**Figure 10 — Functional features of the CSS SLC**

**6.2 Carrying handles**

Carrying handles which can be grasped from below shall be located at the ends of the SLC.

NOTE For CSS-SLCs of 147,5 mm in height, one of the two label holders is part of the main carrying handle.

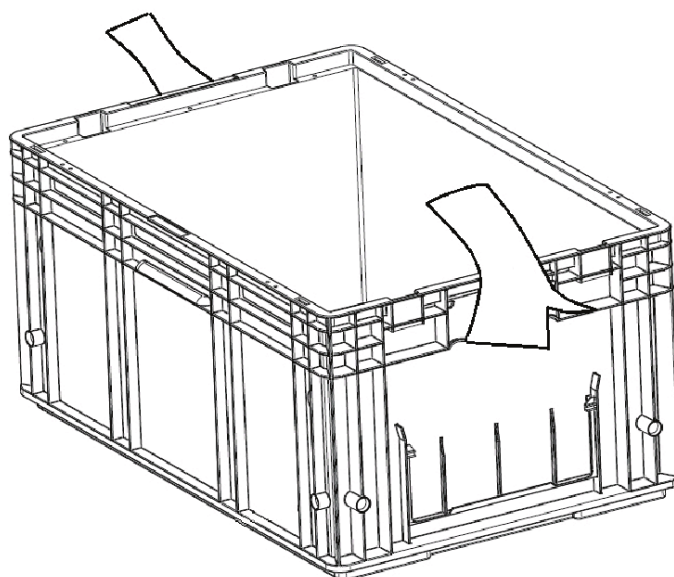

Figure 11 — Manual handling with main handle (+ new picture will be available)

### 6.3 Vertical ribs for lifting grippers

Two vertical ribs for lifting grippers shall be sunk into each of the sides for pull and clamp handling (see [Figure 12](#)).

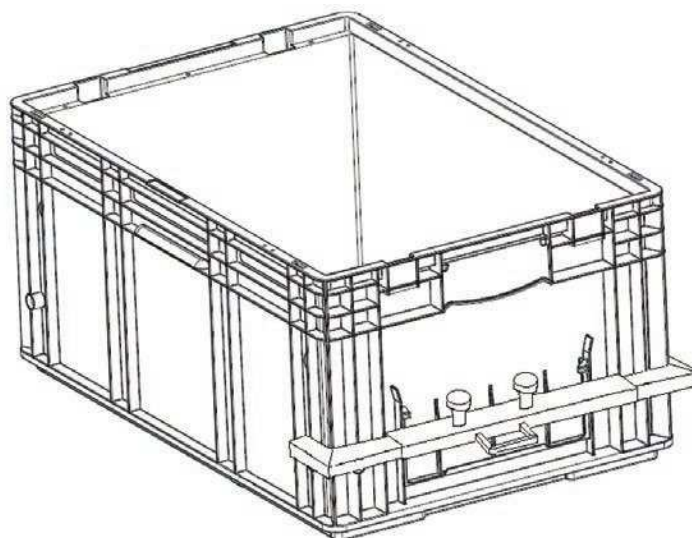

Figure 12 — Handling with vertical ribs for lifting grippers

## 6.4 Centering holes

Two centering holes on each side for automatic handling (see [Figure 13](#)).

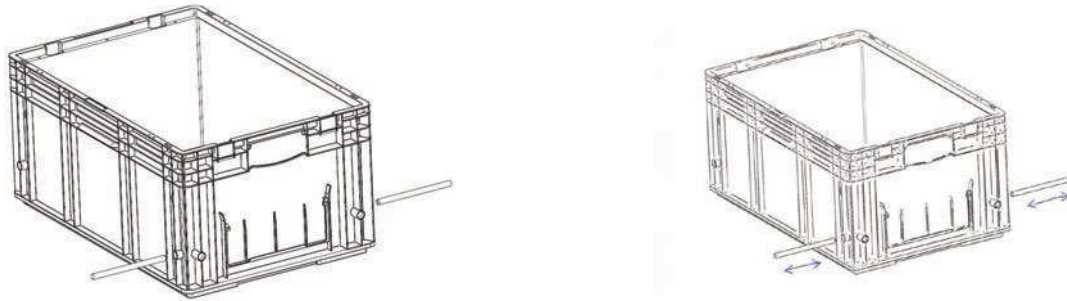

Figure 13 — Centering holes

## 6.5 CSS-SLC base

CSS-SLCs shall have a uniform base with a structure of stacking feet and stacking grooves to ensure CSS-SLC stability and secure column stacking with other CSS-SLCs (see [Figure 14](#)).

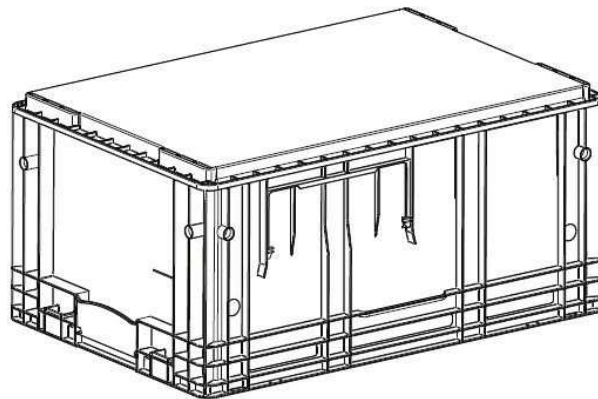

Figure 14 — View of a CSS-SLC base

## 7 Material

The construction material shall be in accordance with ISO 19709-1:—, Clause 8 and Annex C.

## 8 Marking and labelling

Marking and labelling shall be in accordance with ISO 19709-1:—, Clause 9.

NOTE Other data, for example certification identification, may appear by agreement between relevant parties.

## Annex A (informative)

### Column stacking of palletized loads

#### A.1 Column stacking with CSS-SLC on transport pallet with a size of 1 200 mm × 800 mm

Due to its smooth surface CSS-SLC 3 147 can only be used by column stacking for all pallet sizes. Column stacking on transport pallets with a size of 1 200 mm × 800 mm is given in [Figure A.1](#).

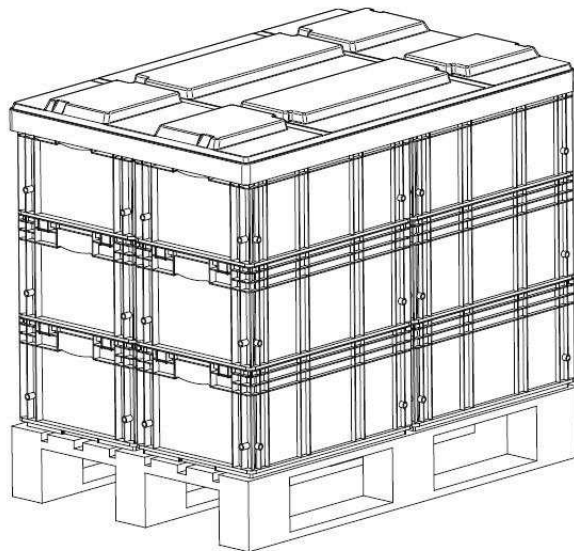

**Figure A.1 — Column stacking with CSS-SLC on Euro flat-pallet with a size of 1 200 mm × 800 mm and a suitable pallet cover type A 1208**

#### A.2 Column stacking on transport pallet with a size of 1 200 mm × 1 000 mm

Column stacking on transport pallets with a size of 1 200 mm × 1 000 mm is given in [Figure A.2](#).

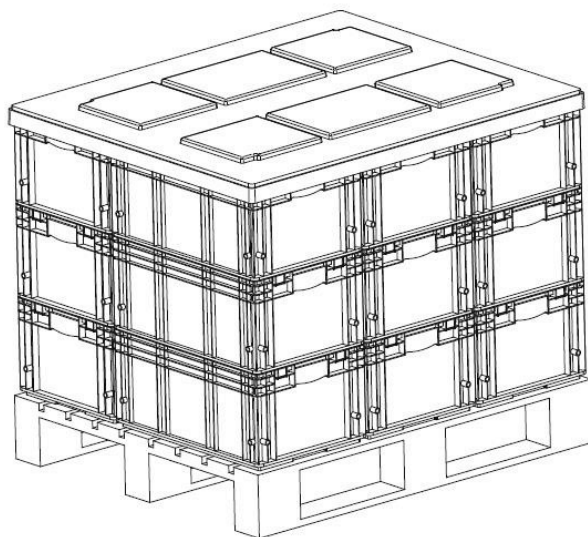

**Figure A.2 — Column stacking with CSS-SLC on Euro flat-pallet with a size of 1 200 mm × 1 000 mm and a suitable pallet cover type A 1 208**

## Annex B (informative)

### Colours

#### B.1 Colour assignment

The short name, nominal size and colour according to RAL colour card standard classic are shown in [Table B.1](#). The conductive SLCs are generally black.

**Table B.1 — Colours for SLCs and lids**

Short name	Nominal dimensions L × W × H mm	Colour
6280 – SLC (CSS)	600 × 400 × 280	RAL 5005
6213 – SLC (CSS)	600 × 400 × 213	RAL 5005
6147 – SLC (CSS)	600 × 400 × 147	RAL 5005
4280 – SLC (CSS)	400 × 300 × 280	RAL 5005
4213 – SLC (CSS)	400 × 300 × 213	RAL 5005
4147 – SLC (CSS)	400 × 300 × 147	RAL 5005
3147 – SLC (CSS)	300 × 200 × 147	RAL 5005
D65 – lid	600 × 400	RAL 5005
D45 – lid	400 × 300	RAL 5005
D35 – lid	300 × 200	RAL 5005

The equivalent CIELAB values for RAL 5005 are  $L^*$  38,320,  $a^*$  -5,295,  $b^*$  -31,823.

#### B.2 Colour tolerances

Newly produced SLCs are tested for compliance with the RAL colour.

The allowable colour variation is specified in the form of the following tolerance limits for the CSS-SLC products:

CSS-SLC:	$\Delta L$ - 0,74	+ 1,88 (brightness)
	$\Delta a$ - 2,18	+ 1,15 (- green/+ red)
	$\Delta b$ - 4,26	+ 2,78 (- blue/+ yellow)

