

First edition
2012-09-15

**Road vehicles — Connection interface
for pyrotechnic devices, two-way and
three-way connections —**

Part 4:
**Pyrotechnic device and harness
connector assembly - type 2**

*Véhicules routiers — Interface de raccordement pour dispositifs
pyrotechniques, deux voies et trois voies —*

*Partie 4: Assemblage du dispositif pyrotechnique et du connecteur
faisceau - type 2*



Reference number
ISO/TS 19072-4:2012(E)

© ISO 2012



COPYRIGHT PROTECTED DOCUMENT

© ISO 2012

All rights reserved. Unless otherwise specified, no part of this publication may be reproduced or utilized in any form or by any means, electronic or mechanical, including photocopying and microfilm, without permission in writing from either ISO at the address below or ISO's member body in the country of the requester.

ISO copyright office
Case postale 56 • CH-1211 Geneva 20
Tel. + 41 22 749 01 11
Fax + 41 22 749 09 47
E-mail copyright@iso.org
Web www.iso.org

Published in Switzerland

Contents

| | Page |
|---|-----------|
| Foreword | iv |
| Introduction | v |
| 1 Scope | 1 |
| 2 Normative references | 1 |
| 3 Terms and definitions | 1 |
| 4 Dimensional features and performance requirements | 2 |
| 4.1 General..... | 2 |
| 4.2 Retainer and squib holder assembly..... | 3 |
| 4.3 Codings and polarization..... | 3 |
| 4.4 Dimensional features and properties for shorting clip function..... | 5 |
| 4.5 Dimensional features and properties for shorting clip function..... | 7 |
| 5 Material characteristics | 7 |
| 5.1 Contacts clip contact specifications..... | 7 |
| 5.2 Retainer..... | 7 |
| Annex A (normative) Three-way (with ground) variant of the pyrotechnic device/initiator harness connector assembly | 8 |

Foreword

ISO (the International Organization for Standardization) is a worldwide federation of national standards bodies (ISO member bodies). The work of preparing International Standards is normally carried out through ISO technical committees. Each member body interested in a subject for which a technical committee has been established has the right to be represented on that committee. International organizations, governmental and non-governmental, in liaison with ISO, also take part in the work. ISO collaborates closely with the International Electrotechnical Commission (IEC) on all matters of electrotechnical standardization.

International Standards are drafted in accordance with the rules given in the ISO/IEC Directives, Part 2.

The main task of technical committees is to prepare International Standards. Draft International Standards adopted by the technical committees are circulated to the member bodies for voting. Publication as an International Standard requires approval by at least 75 % of the member bodies casting a vote.

In other circumstances, particularly when there is an urgent market requirement for such documents, a technical committee may decide to publish other types of document:

- an ISO Publicly Available Specification (ISO/PAS) represents an agreement between technical experts in an ISO working group and is accepted for publication if it is approved by more than 50 % of the members of the parent committee casting a vote;
- an ISO Technical Specification (ISO/TS) represents an agreement between the members of a technical committee and is accepted for publication if it is approved by 2/3 of the members of the committee casting a vote.

An ISO/PAS or ISO/TS is reviewed after three years in order to decide whether it will be confirmed for a further three years, revised to become an International Standard, or withdrawn. If the ISO/PAS or ISO/TS is confirmed, it is reviewed again after a further three years, at which time it must either be transformed into an International Standard or be withdrawn.

Attention is drawn to the possibility that some of the elements of this document may be the subject of patent rights. ISO shall not be held responsible for identifying any or all such patent rights.

ISO/TS 19072-4 was prepared by Technical Committee ISO/TC 22, *Road vehicles*, Subcommittee SC 3, *Electrical and electronic equipment*.

ISO 19072 consists of the following parts, under the general title *Road vehicles — Connection interface for pyrotechnic devices, two-way and three-way connections*:

- *Part 1: Pocket interface definition*
- *Part 2: Test methods and general performances requirements*
- *Part 3: Pyrotechnic device and harness connector assembly – type 1 [Technical Specification]*
- *Part 4: Pyrotechnic device and harness connector assembly - type 2 [Technical Specification]*

Introduction

Road vehicles integrate an increasing number of pyrotechnic devices contributing to occupant safety in vehicles (for example frontal and side air bag, safety belt pretensioner, etc.).

To build the complete system requires a requires a supply of various components from several different equipment suppliers. Vehicle manufacturers need to define a common specification to ensure that connectors designed and produced for the various equipment suppliers can be mated without any difficulty.

In the current design of this vehicle equipment, three areas of connection have been identified:

- connection between the pyrotechnic device (e.g. initiator) and the harness connector;
- connection between the tab holder and the clip holder of the harness connector;
- connection between the harness connector and the electronic control module.

The connection between the pyrotechnic device and the harness connector is the only connection that can be standardised and it forms the subject of this Technical Specification. Due to the location of the safety device in the vehicle, the connector design could be right angle or straight.

Due to the fact that several electrostatic discharge (ESD) protection levels are requested by vehicle manufacturers, a three-way or a two-way without ground option of the pyrotechnic device/initiator harness connector assembly is also defined.

The International Organization for Standardization (ISO) draws attention to the fact it is claimed that compliance with this document may involve the use of a patent.

ISO take no position concerning the evidence, validity and scope of this patent right.

The holder of this patent right has assured the ISO that he is willing to negotiate licences under reasonable and non-discriminatory terms and conditions with applicants throughout the world. In this respect, the statement of the holder of this patent right is registered with ISO. Information may be obtained from:

FCI
145, rue Yves-Le-Coz
78000 Versailles
France

Attention is drawn to the possibility that some of the elements of this document may be the subject of patents rights other than those identified above. ISO shall not be held responsible for identifying any or all such patent rights.

Road vehicles — Connection interface for pyrotechnic devices, two-way and three-way connections —

Part 4: Pyrotechnic device and harness connector assembly - type 2

1 Scope

This Technical Specification defines the general minimum specifications of a type 2 two-way connection interface, linking the pyrotechnic device and harness connector built into a road vehicle.

A three-way with ground variant of the pyrotechnic device/initiator harness connector assembly is also defined (see Annex A).

2 Normative references

The following referenced documents are indispensable for the application of this document. For dated references, only the edition cited applies. For undated references, the latest edition of the referenced document (including any amendments) applies.

ISO 178, *Plastics - Determination of flexural properties*

ISO 8092-2, *Road vehicles - Connections for on-board electrical wiring harnesses - Part 2: Definitions, test methods and general performance requirements*

ISO 14647, *Metallic coatings - Determination of porosity in gold coatings on metal substrates - Nitric acid vapour test*

ISO 19072-1, *Road vehicles - Connection interface for pyrotechnic devices, two-way and three-way connections - Part 1: Pocket interface definition*

ISO 19072-2, *Road vehicles - Connection interface for pyrotechnic devices, two-way and three-way connections - Part 2: Test methods and general performance requirements*

ISO 27874, *Metallic and other inorganic coatings - Electrodeposited gold and gold alloy coatings for electrical, electronic and engineering purposes - Specification and test methods*

RAL colour space system, RAL German Institute for Quality Assurance and Certification e.V.

3 Terms and definitions

For the purposes of this document, the terms and definitions given in ISO 8092-2 and the following apply.

3.1

connector

assembly of contact and housing that terminates conductors for the purpose of providing connection and disconnection to a suitable mating connector

NOTE A male (female) connector is a housing containing male (female) contacts and accessory items. A male connector can be permanently fixed to a wiring harness or to an appliance, e.g. an electronic control unit (ECU). A female connector is, in general, permanently fixed to a wiring harness.

3.2 housing
connector without its contacts

3.3 initiator
part of the pyrotechnical device with two male contacts

3.4 pocket
squib holder inner interface including male contacts

3.5 retainer
ring, generally made of plastic, holding an optional shorting clip and providing coding and electrical insulation

NOTE The shorting clip may be omitted by decision between manufacturer and supplier.

3.6 shorting clip
shunt
metallic bar of the retainer providing the electrical connection between two male contacts

3.7 squib holder
part of the pyrotechnic device holding the initiator and the retainer

4 Dimensional features and performance requirements

4.1 General

The female connector shall be designed to avoid damage to male contacts and the initiator in the case of improper mating. See Figure 1.

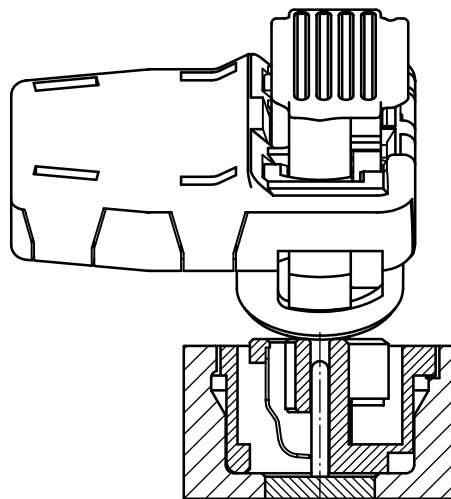

Figure 1 — Example of scoop proof design

Connector, retainer and squib holder assembly shall comply with requirements in ISO 19072-1 and ISO 19072-2.

4.2 Retainer and squib holder assembly

The dimensions of the retainer shall comply with Figure 1. The dimensions of the squib holder interface are defined in ISO 19072-1.

Dimensions in millimetres

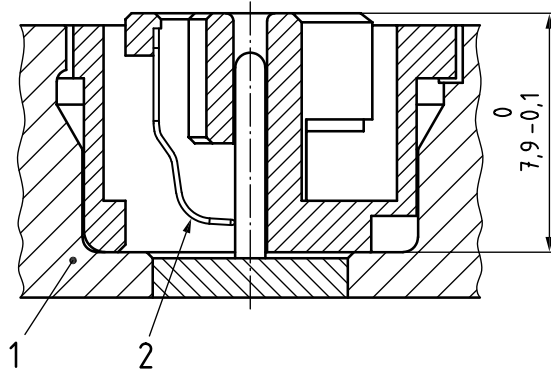

Key

- 1 squib holder
- 2 shorting clip

NOTE Not dimensioned features are not part of the interface description.

Figure 2 — Retainer and squib holder assembly

4.3 Codings and polarization

Coding and polarization are determined by the dimensions and position of the coding keys, each of which has its own colour code (see Figure 2 and Table 1).

The colour code shall be in accordance with RAL¹⁾; however, there needs to be an agreement about the range between the customer and supplier.

Dimensions in millimetres.

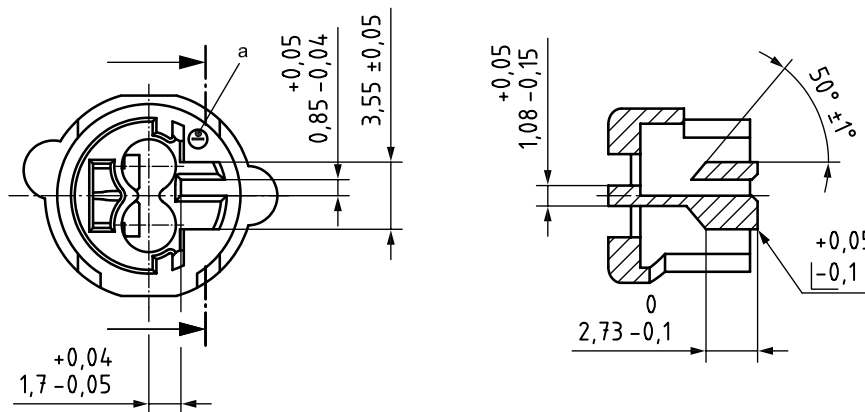

a) Coding I

1) RAL colour space system developed by Reichsausschuß für Lieferbedingungen und Gütesicherung (German Institute for Quality Assurance and Certification e. V.): <https://www.ral-farben.de/>.

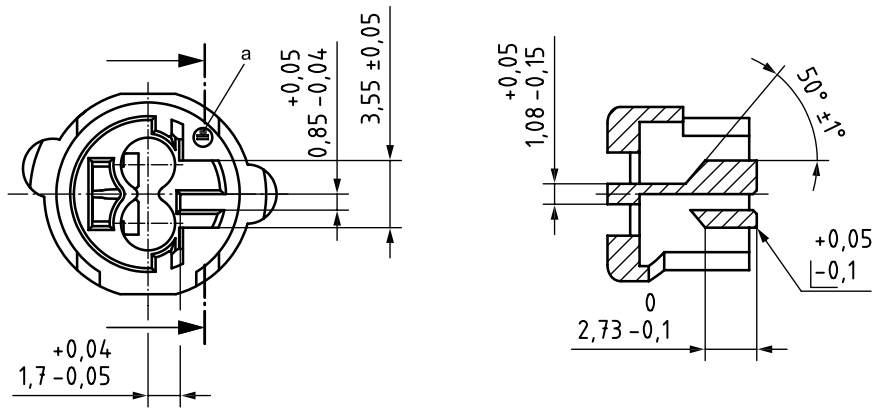

b) Coding II

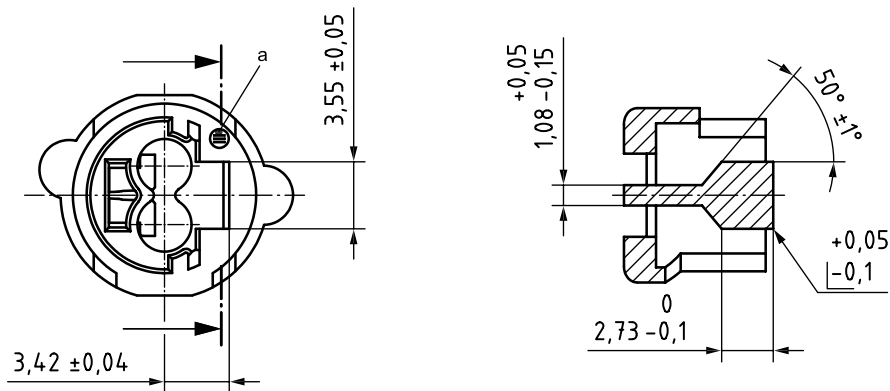

c) Coding III

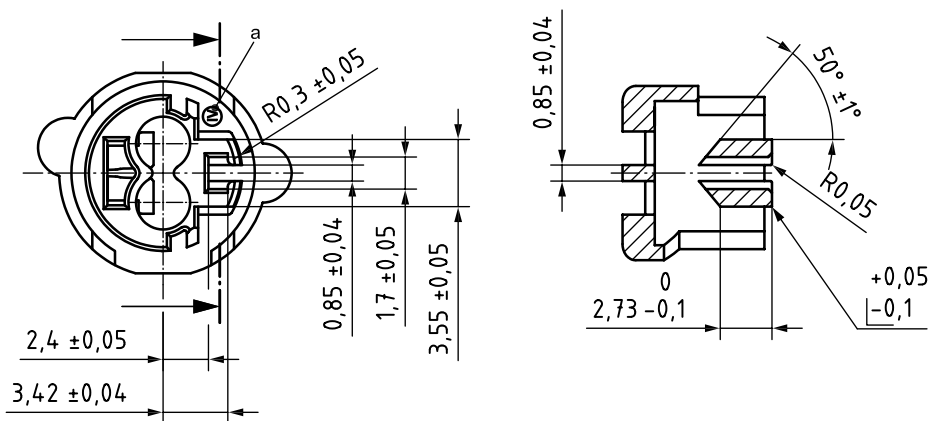

d) Coding IV

a Optional label, indicating the coding by roman numerals.

NOTE Not dimensioned features are not part of the interface description.

Figure 3 — Dimensions and position of coding keys

Table 1 — Type of coding used and assigned colour code

| Colours RAL | | Connection | | | | | | | |
|-------------|------------------------|------------|----|-----|----|-----------|----|-----|----|
| | | Two-way | | | | Three-way | | | |
| No. | Colour description | I | II | III | IV | I | II | III | IV |
| 9011 | Graphite black | X | | | | | | | |
| 6027 | Light green | | X | | | | | | |
| 1021 | Yellow | | | X | | | | | |
| 4005 | Blue purple | | | | X | | | | |
| 2007 | Luminous bright orange | | | | | X | | | |
| 4008 | Signal violet | | | | | | X | | |
| 6017 | May green | | | | | | | X | |
| 9003 | Signal white | | | | | | | | X |

4.4 Dimensional features and properties for shorting clip function

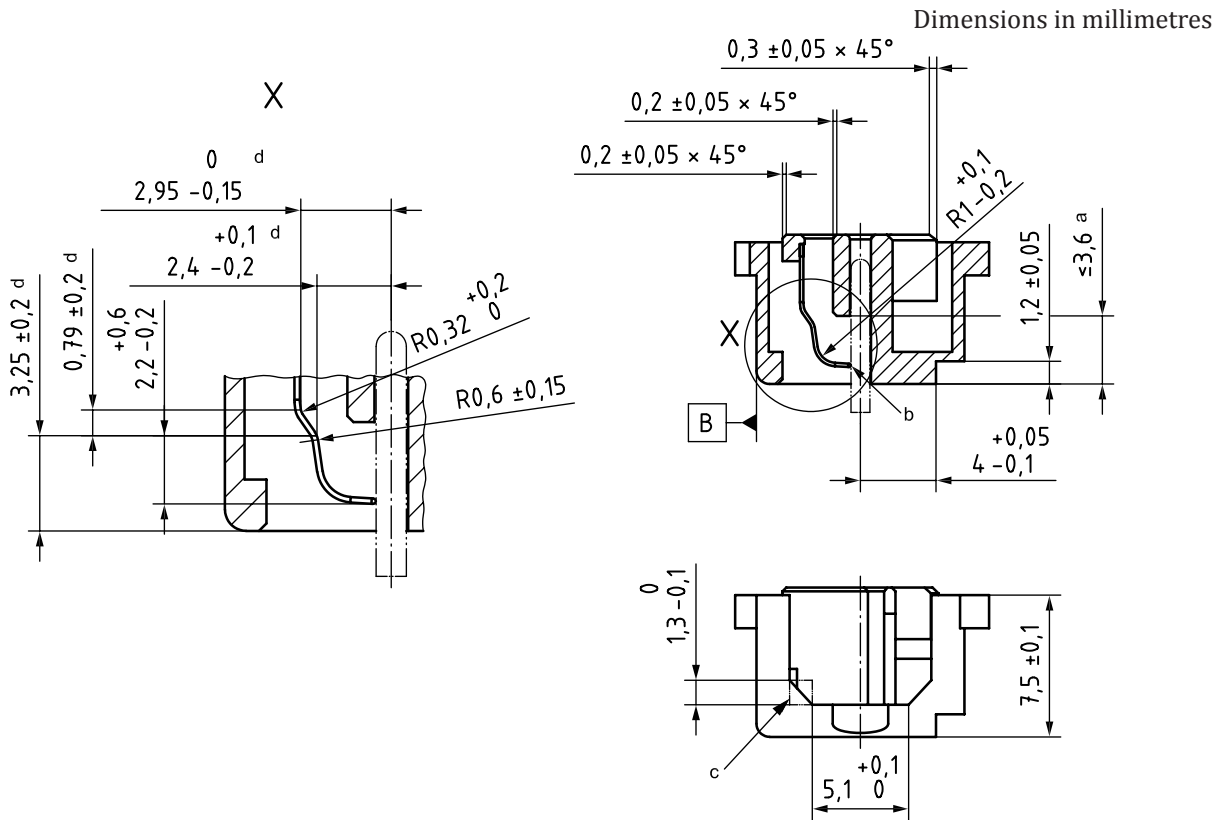

a)

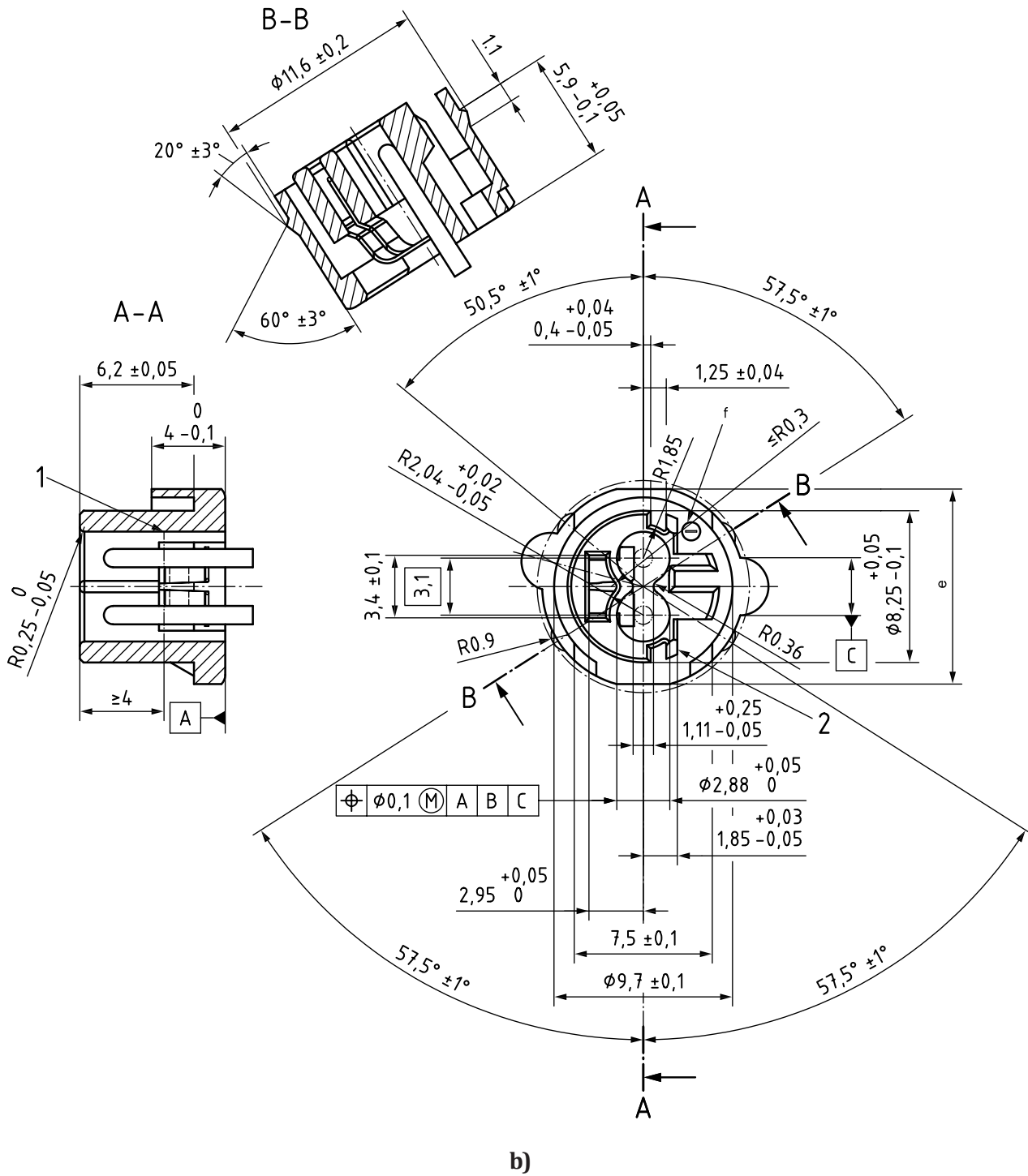

Key

- 1 parting line
- 2 chamfer 0,8 × 30' (2×)
- a Minimum adjusted to dimensions of the inserted clip.
- b Edge free of burrs, radius or chamfer allowed.
- c Optional chamfer for radius.
- d Dimensioning points relate to theoretical intersection points.
- e Flattening optional for manufacturing purposes.

NOTE Not dimensioned features are not part of the interface description.

Figure 4 — Dimensions of area for actuating short-circuit opening in retainer

4.5 Dimensional features and properties for shorting clip function

The dimensional features and properties for the shorting clip function shall comply with Figure 4.

Dimensions in millimetres

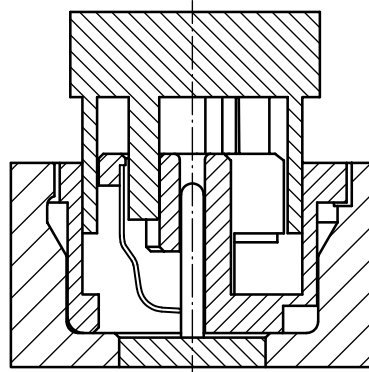

a) Connector is in contact, shorting clip closed

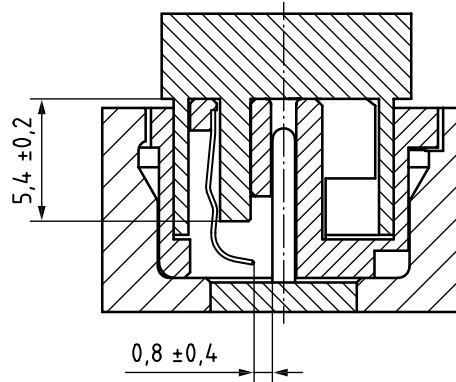

b) Connector mated, with position assurance (CPA), shorting clip open

NOTE Not dimensioned features are not part of the interface description.

Figure 5 — Dimensions of area and opening distance of shorting-clip

5 Material characteristics

5.1 Contacts clip contact specifications

The contact area for the shorting clip (see Figure 3) shall comply with the following characteristics:

- ISO 27874, type (coating purity) and class (coating thickness) to be agreed between customer and supplier, but not less than class 0,5;
- ISO 14647, porosity not greater than 2 pores/mm².

5.2 Retainer

The modulus of elasticity of the plastic used for the retainer shall be at least 4 500 MPa, in compliance with ISO 178.

Annex A (normative)

Three-way (with ground) variant of the pyrotechnic device/ initiator harness connector assembly

The specifications in Clauses 1 to 5 also apply to the three-way with ground variant of the pyrotechnic device/initiator harness connector assembly.

The dimensions of the actuation area for closing the ground contact shall comply with Figure A.1.

The contact area of the ground function shall comply with the following characteristics:

- plating material: tin,
- thickness of plating: 2 µm to 5 µm.

All contents of the main document are applicable for the three-way design.

Dimensions in millimetres

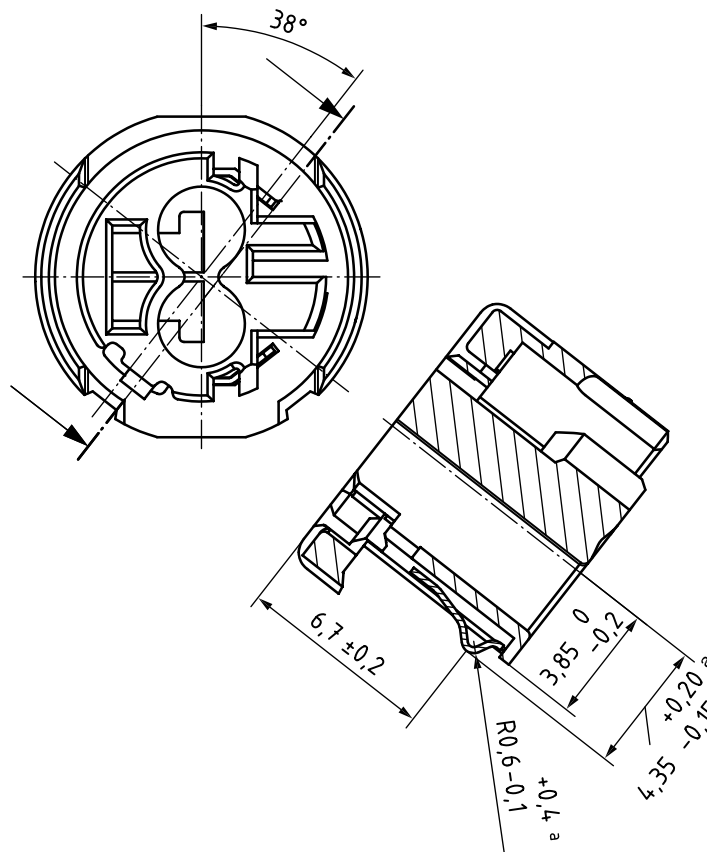

^a Nominal forces between 2 N and 8 N shall be maintained within the dimension indicated.

Figure A.1 — Dimensions of area and nominal forces for ground contact

.....

