

First edition
2014-11-01

**Electronic Fee Collection (EFC) —
Interface definition between DSRC-
OBE and external in-vehicle devices**

*Perception du télépéage — Définition de l'interface entre
l'équipement à bord à communications dédiées à courte portée
(DSRC-OBE) et les dispositifs externes embarqués*



Reference number
ISO/TS 16785:2014(E)

© ISO 2014



COPYRIGHT PROTECTED DOCUMENT

© ISO 2014

All rights reserved. Unless otherwise specified, no part of this publication may be reproduced or utilized otherwise in any form or by any means, electronic or mechanical, including photocopying, or posting on the internet or an intranet, without prior written permission. Permission can be requested from either ISO at the address below or ISO's member body in the country of the requester.

ISO copyright office
Case postale 56 • CH-1211 Geneva 20
Tel. + 41 22 749 01 11
Fax + 41 22 749 09 47
E-mail copyright@iso.org
Web www.iso.org

Published in Switzerland

Contents

| | Page |
|---|-----------|
| Foreword | iv |
| Introduction | v |
| 1 Scope | 1 |
| 2 Normative references | 2 |
| 3 Terms and definitions | 3 |
| 4 Symbols and abbreviated terms | 4 |
| 5 Tolling models with external in-vehicle devices | 5 |
| 5.1 General..... | 5 |
| 5.2 Applicable tolling services..... | 6 |
| 5.3 Basic DSRC tolling..... | 6 |
| 5.4 Mobile-assisted DSRC tolling..... | 7 |
| 5.5 Universal tolling..... | 8 |
| 6 Message sets | 10 |
| 6.1 General..... | 10 |
| 6.2 Payment means status..... | 12 |
| 6.3 Payment fee..... | 12 |
| 6.4 Account update..... | 13 |
| 6.5 Compliance checking data (CCCAttributes)..... | 13 |
| 6.6 Localization data (LacData)..... | 13 |
| 7 Security aspects | 13 |
| 7.1 General..... | 13 |
| 7.2 OBE interface profile..... | 14 |
| Annex A (normative) Data type specification | 15 |
| Annex B (normative) Protocol Implementation Conformance Statement proforma | 17 |
| Annex C (informative) Mobile-assisted DSRC tolling in Korea | 19 |
| Annex D (informative) Other possible tolling models | 22 |
| Annex E (informative) Applicable ITS services | 25 |
| Bibliography | 30 |

Foreword

ISO (the International Organization for Standardization) is a worldwide federation of national standards bodies (ISO member bodies). The work of preparing International Standards is normally carried out through ISO technical committees. Each member body interested in a subject for which a technical committee has been established has the right to be represented on that committee. International organizations, governmental and non-governmental, in liaison with ISO, also take part in the work. ISO collaborates closely with the International Electrotechnical Commission (IEC) on all matters of electrotechnical standardization.

The procedures used to develop this document and those intended for its further maintenance are described in the ISO/IEC Directives, Part 1. In particular the different approval criteria needed for the different types of ISO documents should be noted. This document was drafted in accordance with the editorial rules of the ISO/IEC Directives, Part 2 (see www.iso.org/directives).

Attention is drawn to the possibility that some of the elements of this document may be the subject of patent rights. ISO shall not be held responsible for identifying any or all such patent rights. Details of any patent rights identified during the development of the document will be in the Introduction and/or on the ISO list of patent declarations received (see www.iso.org/patents).

Any trade name used in this document is information given for the convenience of users and does not constitute an endorsement.

For an explanation on the meaning of ISO specific terms and expressions related to conformity assessment, as well as information about ISO's adherence to the WTO principles in the Technical Barriers to Trade (TBT) see the following URL: [Foreword - Supplementary information](#)

The committee responsible for this document is ISO/TC 204, *Intelligent transport systems*.

Introduction

Background and motivation

With regards to reassessing the present fuel tax schemes to cope with prevailing plug-in hybrid vehicle and electric vehicle or introducing congestion charging system to urban roads or inter-urban roads etc., the needs for expanding toll roads are becoming worthy of notice in the world.

In countries where Dedicated Short-Range Communication (DSRC)-based Electronic Fee Collection (EFC) systems were introduced for toll roads and have been operated widely, making their EFC equipment applicable to present non-toll roads, such as urban roads or inter-urban roads, becomes a significant issue to be considered and solved.

There are three cases of introducing EFC to cope with those situations:

- Case-1: DSRC-based EFC should be introduced to new toll roads, as well as present toll roads.
- Case-2: Autonomous EFC should be introduced to new toll roads and present toll roads as replacing.
- Case-3: DSRC-based EFC should be operated for present toll roads as they are, and autonomous EFC should be introduced to new toll roads.

In case of both Case-1 and Case-2, necessary interface definitions and test procedures are already covered by existing EFC standards. However, in Case-3, as shown in [Figure 1](#), current On-Board Equipment (OBE) used for DSRC-based EFC should be considered to be used for autonomous EFC covering new toll roads in keeping consistency with present toll roads.

DSRC-OBE should be expanded functionally by cooperating with external in-vehicle devices composed of a Global Navigation Satellite Systems (GNSS) module and/or a cellular module and/or other related modules; therefore, DSRC-OBE is possible to be reused for new EFC environment consisting of DSRC-based EFC and autonomous systems.

Consequently, an application interface definition between DSRC-OBE and external in-vehicle devices is essential and should be standardized.

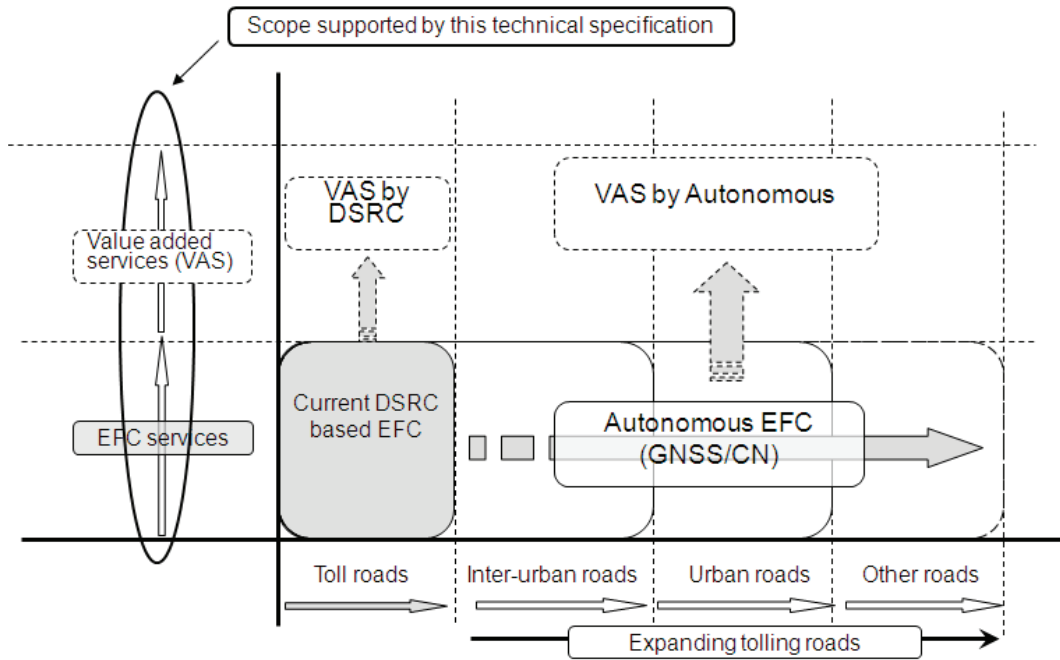

Figure 1 — Image of expanding toll roads and services (Case-3)

Purpose of this Technical Specification

This Technical Specification aims to make it possible for toll road operators to introduce autonomous systems to present non-toll roads by enhancing the functionalities of DSRC-On-Board Equipment (OBE) cooperating with external in-vehicle devices.

As listed below, this Technical Specification defines several tolling models, message sets, and data elements to cope with diversified EFC environment in the main body, as well as data type definition and Protocol Implementation Conformance Statement (PICS) proforma defined in [Annex A](#) and [Annex B](#) respectively. Finally, applicable ITS-services with cooperation of DSRC-OBE and external in-vehicle devices are listed in [Annex E](#) with an example for each of them. This Technical Specification aims at defining the following:

- tolling models with external in-vehicle devices (in main body);
- definitions of message sets and data elements;
- data type definition and PICS proforma (in [Annexes A](#) and [B](#));
- related example and applicable Intelligent Transport System (ITS) services (in [Annex E](#)).

Electronic Fee Collection (EFC) — Interface definition between DSRC-OBE and external in-vehicle devices

1 Scope

This Technical Specification defines an application interface between DSRC-based OBE and external in-vehicle devices to make DSRC-OBE applicable for diversified tolling environment.

The scope of this Technical Specification covers the following items (also shown in [Figure 2](#));

- Definitions of the application interface between DSRC-OBE and external in-vehicle devices (including GNSS, cellular units, CAN interface, etc.).
- Definitions of message sets and data elements on the interface (based on a sets of base standards, such as ISO 14906:2011, ISO/TS 17575, ISO/TS 13141, ISO/TS 12813, and ISO/TS 25110).
- For use in autonomous EFC systems, as well as DSRC-based EFC.
- For use in diversified tolling environment (in toll roads, inner-urban, inter-urban, etc.).
- For use in every kind of DSRC-OBE (based on CEN, UNI, ARIB, TTA, and GB/T).

The following items are out of the scope for this TS:

- Definitions of hardware in the external in-vehicle devices such as GNSS modules, cellular modules, mobile devices, smartphones, etc.
- Definitions of physical interface between DSRC-OBE and external in-vehicle devices such as USB, Bluetooth, etc.
- Definition of any ITS service other than EFC.
- Definition of algorithms for authentication, as well as encryption, and key management.

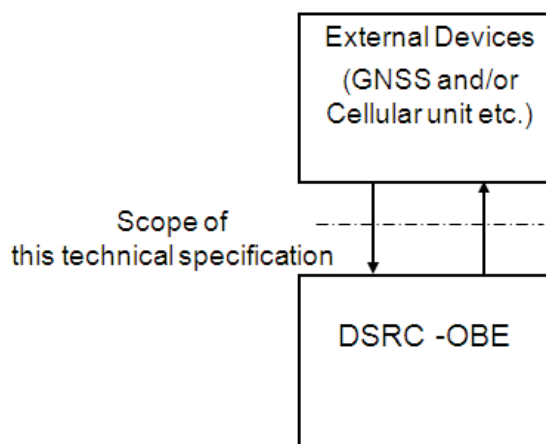

Figure 2 — Scope of this Technical Specification

Applicable DSRC-OBE

When standardizing an application interface between DSRC-OBE and external in-vehicle devices, external in-vehicle devices should be commonly applied for every kind of DSRC-based OBE as shown in [Figure 3](#).

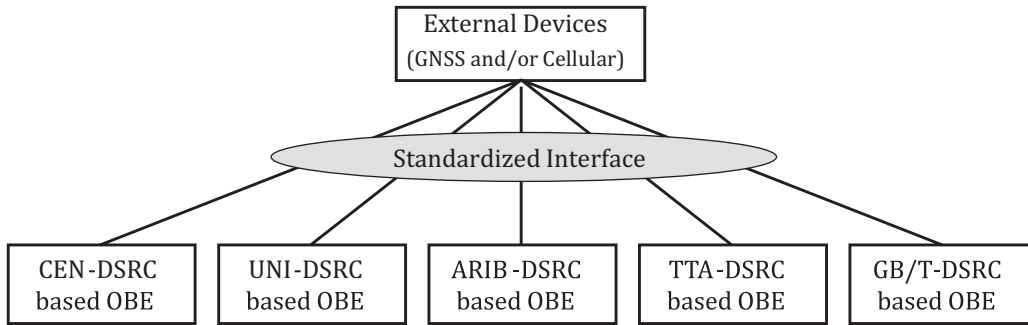

Figure 3 — Applicable DSRC-OBE

The solid and proven DSRC technology makes it possible for DSRC-OBE to have long product-life that enables DSRC-based EFC to be operated still in the future.

On the other hand, each component of external in-vehicle devices has been developed year by year to cope with user’s demands on high performance, as well as multi-functional devices; therefore, they have shorter product-life rather than DSRC-OBE. Once an application interface is standardized, DSRC-OBE can be used continuously for diversified EFC environment with enhanced new external in-vehicle devices. See [Figure 4](#).

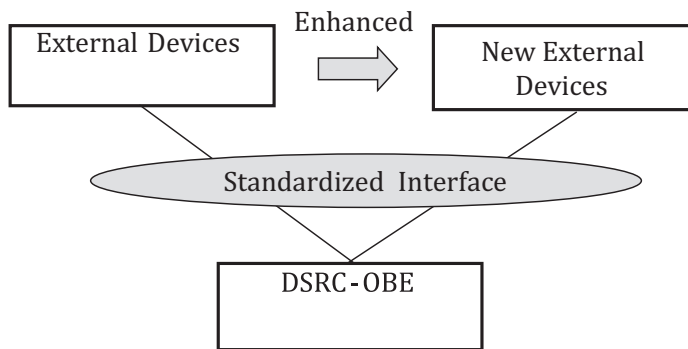

Figure 4 — Applicability for future upgrading

2 Normative references

The following documents, in whole or in part, are normatively referenced in this document and are indispensable for its application. For dated references, only the edition cited applies. For undated references, the latest edition of the referenced document (including any amendments) applies.

ISO/IEC 9798-4:1999, *Information technology — Security techniques — Entity authentication — Part 4: Mechanisms using a cryptographic check function*

ISO 14906:2011, *Electronic Fee Collection — Application interface definition for dedicated short-range communication*

ISO/TS 17575-1:2010, *Electronic Fee Collection — Application interface definition for autonomous systems — Part 1: Charging*

ISO/TS 17575-3:2011, *Electronic Fee Collection — Application interface definition for autonomous systems — Part 3: Context data*

ISO/TS 13141:2010, *Electronic Fee Collection — Localisation augmentation communication for autonomous systems*

ISO/TS 12813:2009, *Electronic Fee Collection — Compliance check communication for autonomous systems*

3 Terms and definitions

For the purposes of this document, the following terms and definitions apply.

3.1

access credentials

trusted attestation or secure module that establishes the claimed identity of an object or application

3.2

attribute

addressable package of data consisting of a single data element or structured sequences of data elements

3.3

autonomous systems

one method of EFC that operate without relying on dedicated road-side infrastructure by employing wide-area technologies such as Global Navigation Satellite Systems (GNSS) and Cellular Communications Networks (CN)

3.4

authenticator

data, possibly encrypted, that is used for authentication

3.5

contract

expression of an agreement between two or more parties concerning the use of the road infrastructure

[SOURCE: ISO 14906:2011, 3.7]

3.6

cryptography

principles, means, and methods for the transformation of data in order to hide its information content, prevent its undetected modification, or prevent its unauthorised use

[SOURCE: ISO 7498-2:1989, 3.3.20, modified]

3.7

data group

class of closely related attributes

3.8

external in-vehicle devices

devices such as mobile phones or dedicated units consisting of GNSS and/or cellular modules that are connected to DSRC-OBE for upgrading the functionalities of it

3.9

issuer

entity responsible for issuing the payment means to the user

3.10

on-board equipment

OBE

equipment located on-board a vehicle including nomadic devices with the function of exchanging information with external systems

Note 1 to entry: The OBE does not need to include payment means.

[SOURCE: ISO 14906:2011, 3.13]

3.11 on-board unit

OBU

minimum component of an *on-board equipment* [3.10], whose functionality always includes at least the support of the DSRC interface

[SOURCE: ISO 14906:2011, 3.14]

3.12 roadside equipment

equipment located along the road, either fixed or mobile

3.13 Toll Service Provider

entity providing toll services in one or more toll domains

Note 1 to entry: In other documents, the terms issuer or contract issuer may be used.

Note 2 to entry: The Toll Service Provider may provide the OBE or may provide only a magnetic card or a smart card to be used with OBE provided by a third party (like a mobile telephone and a SIM card that can be obtained from different parties).

Note 3 to entry: The Toll Service Provider is responsible for the operation (functioning) of the OBE with respect to tolling.

[SOURCE: ISO 17573:2010, 3.23, modified]

3.14 transaction

whole of the exchange of information between two physically separated communication facilities

[SOURCE: ISO 14906:2011, 3.24, modified]

3.15 transaction model

functional model describing the structure of electronic payment transactions

[SOURCE: ISO 14906:2011, 3.25]

4 Symbols and abbreviated terms

For the purpose of this document, the following abbreviations apply throughout the document unless otherwise specified.

| | |
|--------------|--|
| ADU | Application Data Unit |
| APDU | Application Protocol Data Unit |
| ARIB | Association of Radio Industries and Businesses (Communication standardizing body in Japan) |
| ASN.1 | Abstract Syntax Notation One (ISO/IEC 8824-1) |
| CAN | Controller Area Network |
| CCC | Compliance Check Communication (ISO/TS 12813) |
| CE | Central Equipment |
| DSRC | Dedicated Short-Range communication |
| EFC | Electronic Fee Collection |

| | |
|-------------|---|
| GB/T | Guojia Biaozhun/Tuijian (Chinese “Recommended National Standard”) |
| GNSS | Global Navigation Satellite Systems |
| HMI | Human Machine Interface |
| ICC | Integrated Circuit Card |
| ITS | Intelligent Transport Systems |
| LAC | Localization Augmentation Communication (ISO/TS 13141) |
| OBE | On-board Equipment |
| OBU | On-board Unit |
| PMI | Payment Means Issuer |
| PICS | Protocol Implementation Conformance Statement |
| RSE | Roadside Equipment |
| SAM | Secure Application Module |
| TSP | Toll Service Provider |
| TTA | Telecommunications Technology Association (Communication standardizing body in Korea) |
| UNI | Ente Nazionale Italiano di Unificazione |
| USB | Universal Serial Bus |

5 Tolling models with external in-vehicle devices

5.1 General

Multi-functional DSRC-OBE supported with external in-vehicle devices makes current societies smarter with introduction to diversified EFC environment and further ITS services.

There are two kinds of settlement method in EFC, one is on-board account (settlement) system using payment media such as IC card and the other is central account (settlement) system not using payment media. In this Technical Specification, on-board account system in which operational procedure is more complex than central account system is selected as a basic model for diversified EFC.

In the on-board account system, payment media is normally connected to DSRC-OBE and toll amount determined by charging transaction processes between DSRC-OBE and RSE is directly deducted from payment media. On the other hand, payment means can be included in or connected to external in-vehicle devices such as mobile phones. The latter case is shown in [Annex D](#) in which various possible tolling systems other than those mentioned in this clause are introduced.

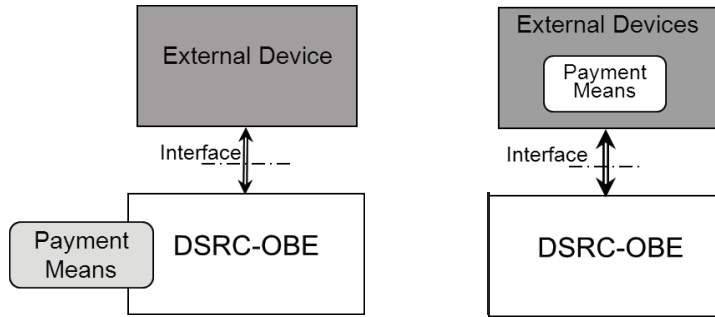

Figure 5 — Connection of payment means (left: in the main body, right: in Annex D)

5.2 Applicable tolling services

Applicable tolling services provided by a combination of DSRC-OBE and external in-vehicle devices are shown in Table 1. The basic DSRC tolling is the present DSRC tolling service as described in 5.3 and DSRC-OBE is used as the basic unit for extended tolling services and other ITS services as described in Annex E. As one of extended tolling services, mobile-assisted DSRC tolling performs auto-loading function for payment means via cellular networks as described in 5.4.

Universal tolling services both for DSRC tolling and autonomous system described in 5.5 that performed with DSRC-OBE and connected external in-vehicle devices are composed of a GNSS receiver, a CN device, and other optional components.

Table 1 — Applicable tolling services with external in-vehicle devices

| Tolling services | DSRC-OBE | Components of external in-vehicle devices | | | | | | References |
|---------------------------------|----------|---|-----------|-----|----------------|--------------------|--------------|------------|
| | | GNSS | CN device | HMI | Motion sensors | Digital tachograph | CAN bus unit | |
| 1. Basic DSRC tolling | M | | | | | | | 5.3 |
| 2. Mobile-assisted DSRC tolling | M | | M | | | | | 5.4 |
| 3. Universal tolling | M | M | M | M | M | O | O | 5.5 |

M: Mandatory, O: Option

5.3 Basic DSRC tolling

Present DSRC-OBE used for tolling with payment means and its operating environment is shown in Figure 5. Figure 5 shows prepayment settlement; however, post-payment settlement has the same environment except for reloading operation.

In case of prepayment settlement, the most inconvenient issue for users is reloading to payment means by the terminal installed at the toll plaza or service area along toll roads or contracted shops and so on before payment means getting low balance. See Figure 6.

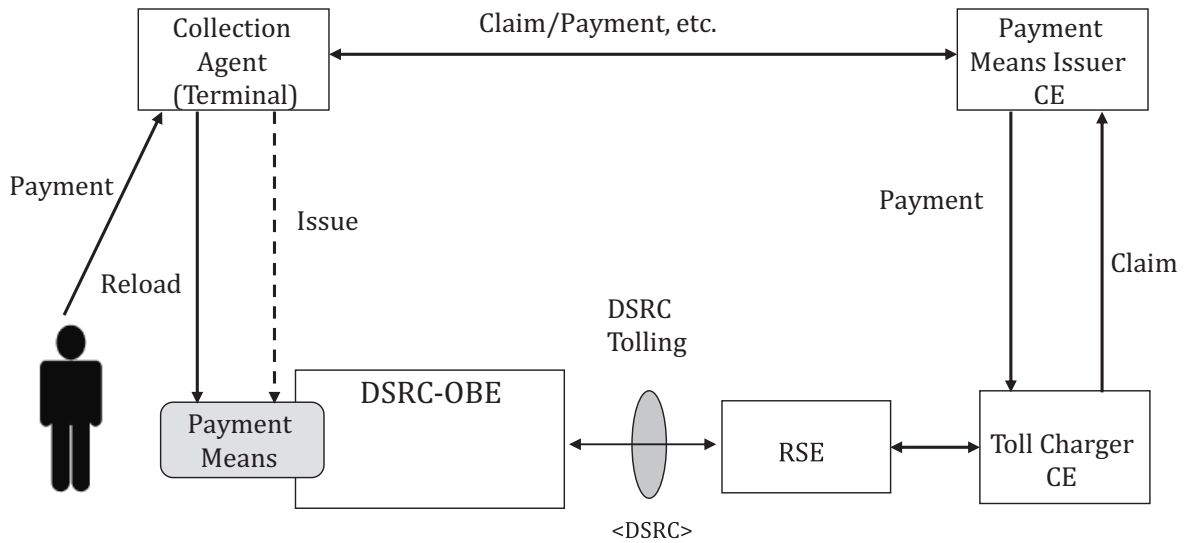

Figure 6 — Basic DSRC tolling

5.4 Mobile-assisted DSRC tolling

5.4.1 Operating environment

An expanded configuration of DSRC-OBE is connected with external in-vehicle devices such as mobile phones used for auto-reloading into the payment means instead of manually reloading through the terminal, which is shown in [Figure 7](#).

This service is performed by DSRC-OBE connected with a mobile phone via an interface. In this system, when the remaining balance in the payment means lowers at the predetermined balance, reload data are transferred from the payment means issuer to DSRC-OBE through a mobile phone and then the payment means balance is updated. A detailed description is shown in [Annex C](#).

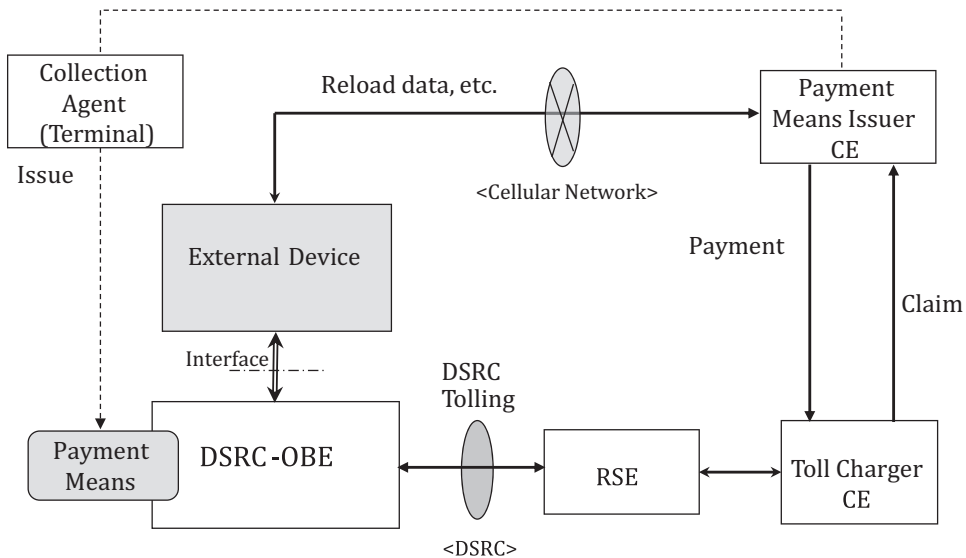

Figure 7 — Mobile-assisted DSRC tolling

5.4.2 Message flows

Application message sequence between external in-vehicle devices and DSRC-OBE after exchanging data for connection and security are as follows and general message flows are shown in [Figure 8](#).

- a) The payment means status is sent from DSRC-OBE to external in-vehicle devices after exchanging data for connection and security.
- b) If account Status in the payment means status is low or empty, external in-vehicle devices send Account update request to the payment means issuer through a cellular network.
- c) The payment means issuer sends Account update containing the predefined value data to external in-vehicle devices if User account is valid after checking.
- d) External in-vehicle devices send Account update to DSRC-OBE, then DSRC-OBE updates payment means.

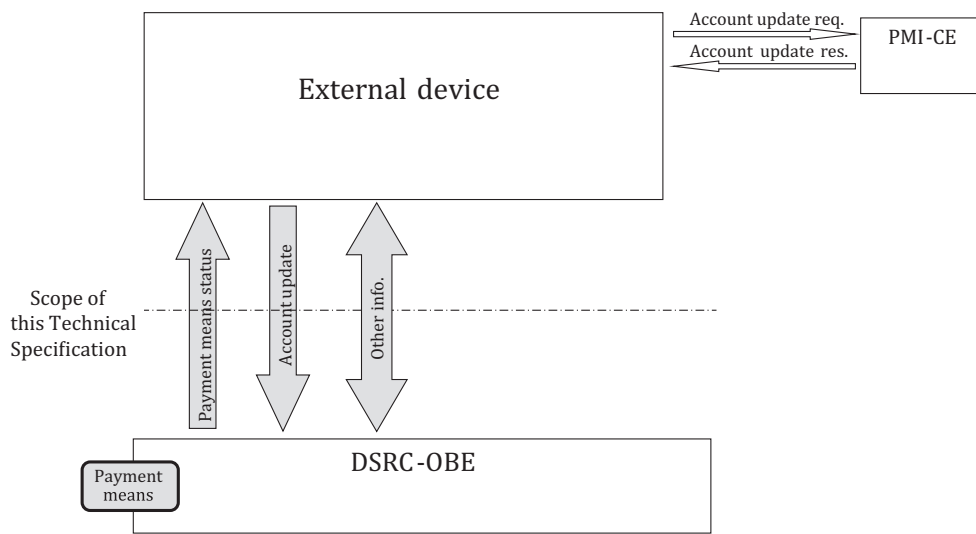

Figure 8 — Message flows for mobile-assisted DSRC tolling

5.5 Universal tolling

5.5.1 Operating environment

The other tolling model in which DSRC-OBE is connected with external in-vehicle devices is Universal tolling which supports both autonomous system and DSRC tolling as shown in [Figure 9](#). In Universal tolling, external in-vehicle devices consist of various components listed in [Table 1](#).

The minimum configuration of external in-vehicle devices is composed of a GNSS receiver, a cellular communication module, and a data processing module. The following components are considered as optional parts for implementation that depends on the requirements of autonomous system:

- a) HMI
- b) Motion sensors
- c) Digital tachograph
- d) CAN bus unit

External in-vehicle devices are connected with the payment means issuer for exchanging reload-related message and with Toll Service Provider for exchanging autonomous tolling-related message defined by ISO/TS 17575-1 through cellular networks.

DSRC-OBE is connected with individual RSEs to communicate transactions for DSRC Tolling, Compliance Checking, and Localization through DSRC.

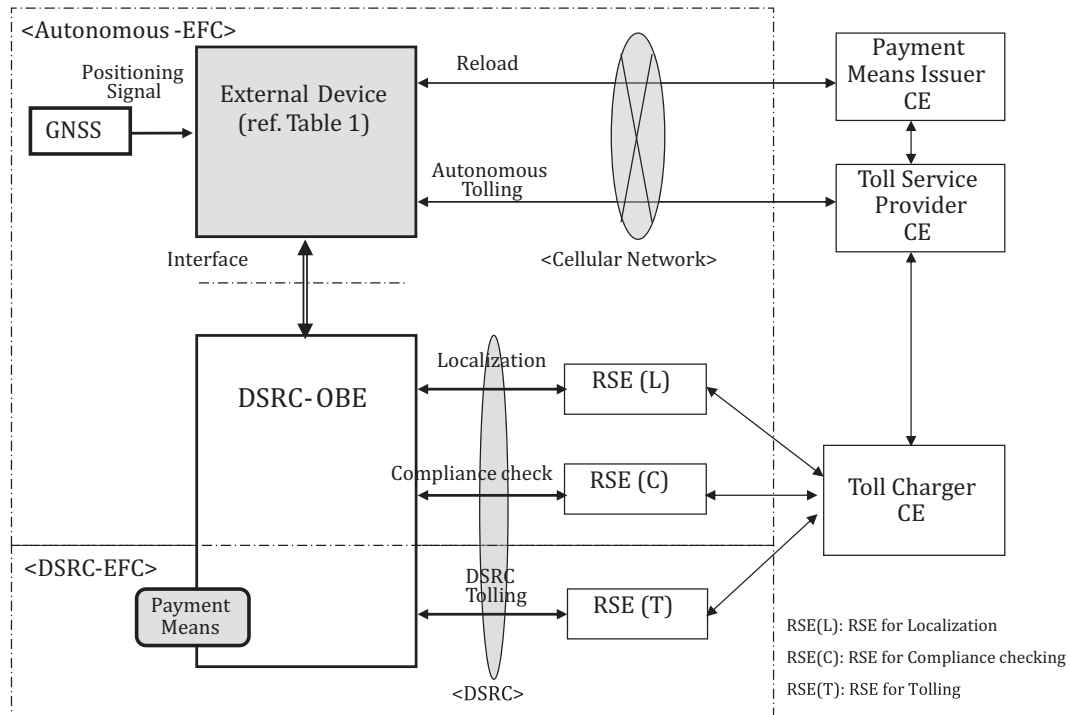

Figure 9 — Universal tolling

5.5.2 Message sequences and flows

Application message flows between external in-vehicle devices and DSRC-OBE after exchanging data for the initial connection and the authentication are shown in [Figure 10](#). With message exchanges between DSRC-OBE and external in-vehicle devices, the following processes are executed.

a) Auto-reloading process for payment means

Payment means status

Account update

b) Payment process

Payment fee

c) Compliance check process

Compliance check data (C.C data)

d) Localization process

Localization data (LAC data)

e) HMI process etc.

Others

Message exchanges between external in-vehicle devices and the payment means issuer are Account update request and response relating with Auto-reloading of payment means. Message exchanges between external in-vehicle devices and the Toll Service Provider are Charge report and Context data defined by ISO/TS 17575-3.

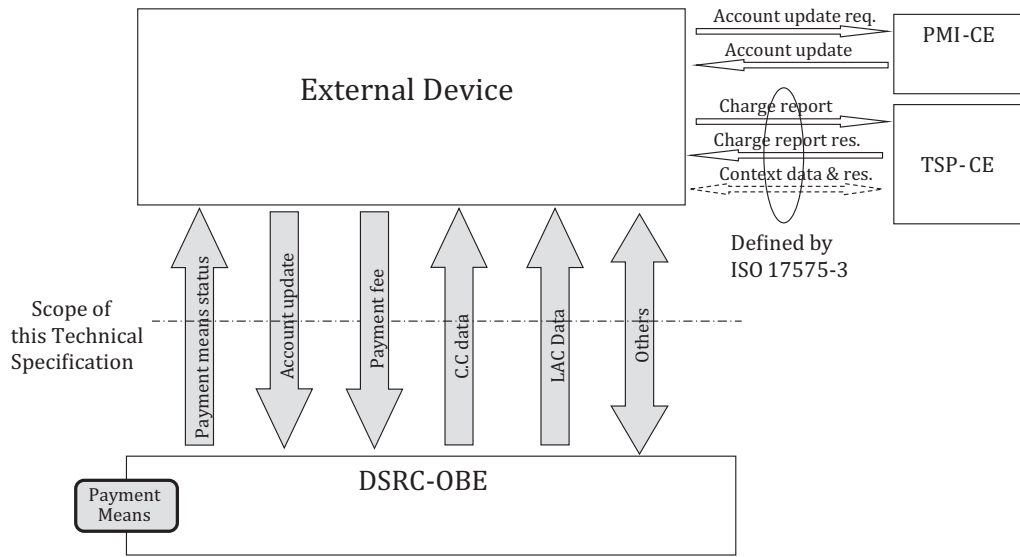

Figure 10 — Message flows for Universal tolling

6 Message sets

6.1 General

Message sets exchanged on the interface between DSRC-OBE and external in-vehicle devices are listed in [Table 2](#) and each data element id defined in the latter sub-clauses.

Table 2 — Message sets

| Message sets | | Description | References |
|-------------------------|---------------------------------|---|----------------|
| Name | Data elements | | |
| 1. Payment means status | paymentMode | Defines payment mode of payment means | Newly defined |
| | accountStatus | Indicates card status such as positive value for tolling or not, and other information | ISO/TS 17575-1 |
| | paymentMeansBalance (valueData) | Indicates balance (value) data of payment means | ISO 14906:2011 |
| | paymentMeans | Defines the characteristics of payment means. | ISO 14906:2011 |
| 2. Payment fee | paymentFeeAmount | Defines the value of the fee being charged for the service. | ISO 14906:2011 |
| | paymentFeeUnit | Defines the unit in which the fee is expressed. | ISO 14906:2011 |
| 3. Account update | reloadAccount | Instructs the OBE application to either top up the respective type of account with a predefined value or not. | ISO/TS 17575-1 |
| | setAccount | Sets a specific value to the account. | ISO/TS 17575-1 |
| | addToAccount | Adds a specific value to the account | ISO/TS 17575-1 |

Table 2 (continued)

| Message sets | | Description | References |
|---|--|--|--------------------------------|
| Name | Data elements | | |
| 4. Compliance checking data (CCCAttributes) | timeOfCCCRecord | The time at which CCC transaction occurred. | ISO/TS 17575-1 |
| | axlesHistory | Used to check if the change of the declared number of axles occurred during the trip, e.g. just before a CCC. | ISO/TS 12813 |
| | communicationStatus | Used to check if the toll data communication is operational (not tampered with). | ISO/TS 12813 |
| | gnssStatus | Used to check if GNSS reception is operational (not tampered with). | ISO/TS 12813 |
| | distRecStatus | Used to check distance recording accuracy using two successive beacon, or quality of the odometer's signal. | ISO/TS 12813 |
| | activeContext | Used to check if the current context(s) are active in the OBE. | ISO/TS 12813 |
| | obeHistory | Used to prevent fraud by incorrect deactivation while in transit. | ISO/TS 12813 |
| 5. Localization data (LacData) | LACOperator | Identify the organization that operates LAC. | ISO/TS 13141 |
| | rSEId | Identify an operator-specific identification of the RSE. | ISO/TS 13141 |
| | latitude | The latitudinal coordinate of the centre of the road surface covered by the specific LAC implementation. | ISO/TS 13141 |
| | longitude | The longitudinal coordinate of the centre of the road surface covered by the specific LAC implementation. | ISO/TS 13141 |
| | Altitude | The altitudinal coordinate of the centre of the road surface covered by the specific LAC implementation. | ISO/TS 13141 |
| | tollCharger | Identify the Toll Charger that owns the toll scheme for which LAC is operated. | ISO/TS 13141 |
| | chargeObject | Identify charge object for which LAC is operated, according to the local definition of the Toll Charger owning the respective toll scheme, e.g. road section, passage of cordon. | ISO/TS 13141 ISO/TS 17575-1 |
| | distanceToObject | The distance in metres to the charge object as identified by the element chargeObject, from the point of operation of the LAC. | ISO/TS 13141 |
| | lACTime | The time at which the LAC transaction occurred. | ISO/TS 13141 |
| | mAC1 | Security-related data regarding the LacData. | ISO/TS 13141 |
| mAC2 | Security-related data regarding the LacData. | ISO/TS 13141 | |

6.2 Payment means status

6.2.1 Payment means status

Payment means have the following status information which is checked for payment mode and validation before payment process.

6.2.2 paymentMode

Payment means have the following respective payment mode as defined and operated by Issuers.

```
Pre-payment (prepaid card)
Post-payment (credit card or other post-pay card)
immediate payment (bank card)
others
```

6.2.3 accountStatus

In case of pre-payment, external in-vehicle devices can get the status of the respective account from DSRC-OBE. The respective data element `accountStatus` can have the following values:

```
ok, i.e. contains a positive value above a defined threshold
low, i.e. contains a positive value below a defined threshold
empty, i.e. contains the value zero
negative, i.e. contains a value below zero
```

6.2.4 paymentMeansBalance (valueData)

In case of pre-payment, external in-vehicle devices have an option to get the payment means balance (value data) from the payment means directly by sending the read command to it through DSRC-OBE.

6.2.5 paymentMeans

In case of post-payment, the data element `paymentMeans` is a unique identification of an individual road user account. The respective data type is defined in ISO 14906. It consists of the following data elements which indicate the issue's specified restrictions, on the geographic usage and service allowed for the applications.

```
personalAccountNumber
paymentMeansExpiryDate
paymentMeansUsageControl
```

6.3 Payment fee

6.3.1 PaymentFee

The fee (toll, charge, or fare) is defined as requested by the service provider for the service provided or to be provided.

6.3.2 paymentFeeAmount

The data element `paymentFeeAmount` is the value of the fee being charged for the service.

6.3.3 paymentFeeUnit

The data element `paymentFeeUnit` is the unit in which the fee is expressed.

6.4 Account update

6.4.1 AccountUpdate

In case of Pre-payment, the account of payment means can be updated by PMI-CE through a Cellular network. The respective data element `AccountUpdate` consists of the following three parts providing three options for updating the account:

Either a predefined value is added to the current balance (through the data element `reloadAccount`) or the new balance is explicitly transmitted (through the data element `setAccount`). The third option adds a given quantity to the account (through the data element `addToAccount`). The update sets limits in credit, distance, time (defining a point of time until expiry), duration (defining duration until expiry), or a number of detected events.

6.4.2 reloadAccount

A predefined value is added to the current balance through the data element `reloadAccount`. The predefined value must be set in advance, either by the initial configuration process for the frontend or using the update mechanism.

Security measures can be applied to the data element `reloadAccount` using the element `reloadAuthenticator`.

6.4.3 setAccount

The new balance is explicitly transmitted through the data element `setAccount`. The Data element `setAccount` is of type `newAccountLimit`, which sets the account to a specific value.

Security measures can be applied to the data element `newAccount` using the element `newAuthenticator`.

6.4.4 addToAccount

The third option adds a given quantity to the account through the data element `addToAccount`. The Data element `addToAccount` is of type `AddToAccount`, which adds a specific value to the account.

Security measures can be applied to the data element `addToAccount` using the element `addAuthenticator`.

6.5 Compliance checking data (CCCAttributes)

The data in the structure `CCCAttributes` are defined in and imported from ISO/TS 17575-1 and ISO/TS 12813.

6.6 Localization data (LacData)

The data in the structure `LacData` are defined in and imported from ISO/TS 13141.

7 Security aspects

7.1 General

The interface between DSRC-OBE and external in-vehicle devices is exposed to being attacked so the following requirements should be taken into account (referring to requirements listed in CEN/TS 16439 EFC Security Framework):

- data exchange shall only be done between authenticated entities for the respective data (RQ.IF.20);

- data exchange shall guarantee data confidentiality (RQ.IF.10);
- data exchange shall guarantee data integrity (RQ.IF.11).

To meet the above requirements, mutual authentication between DSRC-OBE and external in-vehicle devices, an encryption for exchanged data, and message authentication for manipulation checking should be the essential security measures.

A conformance test of DSRC-OBE relating to security measures should be conducted with being connected to external in-vehicle devices, as well as implemented EFC functions required both for DSRC tolling and autonomous systems.

7.2 OBE interface profile

Mutual authentication between DSRC-OBE and external in-vehicle devices should be three-way authentication based on ISO/IEC 9798-4, and an encryption should be applied for exchanged data on the interface. However, definition of algorithm for authentication and encryption and key management should be out of scope of this Technical Specification. See [Figure 11](#).

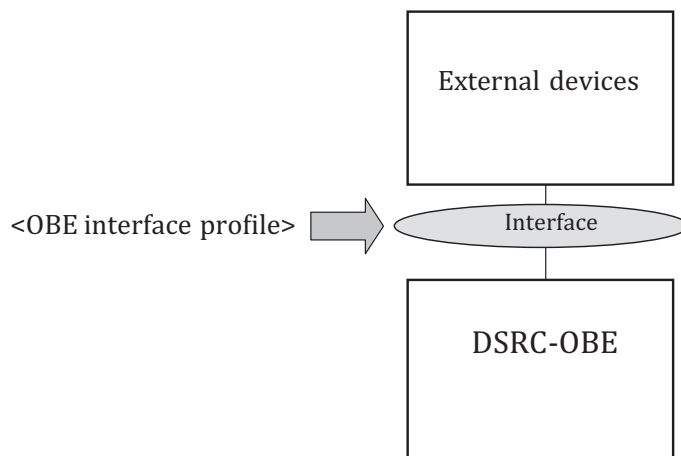

Figure 11 — OBE interface profile

Annex A (normative)

Data type specification

This clause contains the ASN.1 definition of

- the data types related to the Tolling models described in [Clause 5](#),
- the data types related to the Message sets as specified in [Clause 6](#),
- the ASN.1 container types for ISO Layer 7,

using the Abstract Syntax Notation One (ASN.1) technique according to ISO/IEC 8824-1. The packed encoding rules according to ISO/IEC 8825-2 shall be applied.

```
EfcDsrcObeExtDevices {iso(1) standard(0) 16785 version1(1)}
DEFINITIONS AUTOMATIC TAGS
::= BEGIN

IMPORTS
TollCharger, AccountStatus, ChargeObjectId, ReloadAccount, NewAccountLimit, AddToAccount
FROM ChargingModule {iso standard 17575 modules(0) efc(0) version(1)}

-- Imports data attributes and elements from ISO 17575-1

Latitude, Longitude, VehicleAxlesHistory, CommunicationStatus, GnssStatus,
DistanceRecordingStatus, ActiveContext, OBEStatusHistory
FROM CccModule {iso standard 12813 modules(0) ccc(0) version(1)}

-- imports data attributes and elements from ISO 12813

Time
FROM DSRCDATA {iso standard 14906 modules (0) dsrc (1) version (1)}

PaymentMeansBalance, PaymentMeans, PayUnit, DateAndTime, Provider
FROM EfcModule {iso standard 14906 modules(0) efc(0) version(1)};

-- imports data attributes and elements from the efc module of ISO 14906:2011

-- Note the followings are the definitions of the Message sets

-----
-- Level 1 --
-----

PaymentMeansStatus ::= SEQUENCE {
    paymentMode                Int2,
    accountStatus              AccountStatus,
    paymentMeansBalance        PaymentMeansBalance,
    paymentMeans                PaymentMeans
}

PaymentFee ::= SEQUENCE {
    paymentFeeAmount           Int2,
    paymentFeeUnit             PayUnit
}

AccountUpdate ::= CHOICE {
    reloadAccount              ReloadAccount,
    setAccount                  NewAccountLimit,
    addToAccount                AddToAccount
}

```

ISO/TS 16785:2014(E)

```
CCCAttributes ::= SEQUENCE {
    timeOfCCCRecord      DateAndTime OPTIONAL,
    axlesHistory         VehicleAxlesHistory OPTIONAL,
    commStatus           CommunicationStatus OPTIONAL,
    gnssStatus           GnssStatus OPTIONAL,
    distRecStatus        DistanceRecordingStatus OPTIONAL,
    activeContext        ActiveContext OPTIONAL,
    obeHistory           OBEStatusHistory OPTIONAL
}
```

```
LacData ::= SEQUENCE {
    lacOperator          Provider,
    rSEId               Int2,
    latitude             Latitude,
    longitude            Longitude,
    altitude             INT2Signed,
    tollCharger         TollCharger,
    chargeObject        ChargeObjectId,
    distanceToObject    INT2Signed,
    lacTime             Time,
    mAC1                OCTET STRING (SIZE (8)),
    mAC2                OCTET STRING (SIZE (8))
}
```

-- Level 2 --

-- NOTE: The following are the definitions of the Payment related data elements

```
SignedValue ::= CHOICE {
    positive          INTEGER (0..8388607),
    negative          INTEGER (-8388608..-1)
}
```

```
Int2 ::= INTEGER(0..65535)
```

```
INT2Signed ::= INTEGER (-32768..32767)
```

END

Annex B (normative)

Protocol Implementation Conformance Statement proforma

B.1 Introduction

This clause contains the Protocol Implementation Conformance Statements (PICS) proforma to be used for Front-End implementation of the charge report protocol defined in [Clause 6](#) and [Annex A](#).

B.2 Message sets

| Element | Status | Implemented |
|---|----------|-------------|
| Payment means status | optional | Yes/No |
| Payment fee | optional | Yes/No |
| Account update | optional | Yes/No |
| Compliance checking data (CCCAttribute) | optional | Yes/No |
| Localization data (LacData) | optional | Yes/No |
| Other data | optional | Yes/No |

B.3 Data elements

B.3.1 Payment means status

| Element | Status | Implemented |
|----------------------------------|----------|-------------|
| paymentMode | optional | Yes/No |
| accountStatus | optional | Yes/No |
| paymentMeansBalance (Value data) | optional | Yes/No |
| paymentMeans | optional | Yes/No |

B.3.2 Payment fee

| Element | Status | Implemented |
|------------------|----------|-------------|
| paymentFeeAmount | optional | Yes/No |
| paymentFeeUnit | optional | Yes/No |

B.3.3 Account update

| Element | Status | Implemented |
|---------------|----------|-------------|
| reloadAccount | optional | Yes/No |
| setAccount | optional | Yes/No |
| addToAccount | optional | Yes/No |

B.3.4 Compliance checking data

| Account type | Status | Implemented |
|-----------------|----------|-------------|
| timeOfCCCRecord | optional | Yes/No |
| axleHistory | optional | Yes/No |
| commStatus | optional | Yes/No |
| gnssStatus | optional | Yes/No |
| disRecStatus | optional | Yes/No |
| activeContext | optional | Yes/No |
| obeHistory | optional | Yes/No |

B.3.5 Localization data

| Account type | Status | Implemented |
|------------------|----------|-------------|
| LACOperator | optional | Yes/No |
| rSEId | optional | Yes/No |
| latitude | optional | Yes/No |
| longitude | optional | Yes/No |
| altitude | optional | Yes/No |
| tollCharger | optional | Yes/No |
| chargeObject | optional | Yes/No |
| DistanceToObject | optional | Yes/No |
| lACTime | optional | Yes/No |
| mAC1 | optional | Yes/No |
| mAC2 | optional | Yes/No |

Annex C (informative)

Mobile-assisted DSRC tolling in Korea

C.1 General

This chapter describes the services and procedures used for ICC reload transaction, via Bluetooth communication between OBU and a mobile phone in Korea. See [Figure C.1](#).

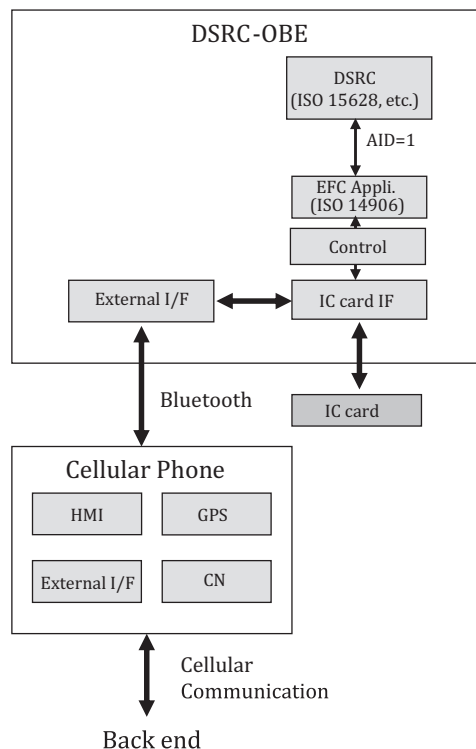

Figure C.1 — Configuration of Bluetooth OBU service

A Bluetooth OBU mainly consists of a DSRC communication unit, a Bluetooth communication unit, an ICC interface unit, and an HMI unit. After registering the Bluetooth OBU to the driver's mobile phone, several services are possible such as

- ICC reload,
- ICC balance low limit setting (In case of lack of balance, voice and message inform),
- Reload amount of money setting (auto reload),
- ICC debit notice (voice and message inform), and
- ICC transaction log query (up to 50), and etc.

In addition to the 5 % to 20 % debit discount in the ETC lane, 3 % credit overcharging benefit is given if the Bluetooth OBU is used at reload transaction.

C.2 Services description

Once Bluetooth communication link is set up between OBU and a mobile phone, the mobile phone sends ICC APDU command directly to ICC and receives ICC response back, so that all kinds of ICC-related transaction can take place such as ICC reload, ICC debit query, ICC transaction log query, ICC info query, and so on.

C.3 Reload transaction

ICC reload procedure is as follows:

- a) Driver runs ICC reload application on mobile phone.
- b) Mobile phone links with OBU via Bluetooth communication.
- c) Mobile phone links with backend system via cellular network (user's account, Host SAM).
- d) Driver inputs the amount of money for ICC reload on the mobile phone.
- e) According to reload transaction flow in application software, the mobile phone sends ICC command to OBU and SAM command to backend Host SAM.
- f) OBU transfers its command to ICC. If any of ICC response is returned, OBU transfers its response to mobile phone.
- g) Backend system transfers its command to Host SAM. If any of Host SAM responses is returned, backend system transfers its response to the mobile phone.
- h) After a successful ICC reload transaction is finally done, the mobile phone informs the driver of the transaction result by using voice and message.

C.4 Debit transaction

If ICC debit transaction takes place at the ETC toll plaza, regardless of correct or incorrect transaction, this event is delivered from OBU to a mobile phone via Bluetooth communication. Because the Bluetooth link between OBU and the mobile phone is broken in normal situation, OBU attempts to link setup with the mobile phone and delivers the ICC debit transaction result to the mobile phone. Afterwards, the mobile phone informs the driver of the transaction result by using voice message.

C.5 ASN.1-module

```

OBU-MessageType ::= CHOICE {
    obu-version-request          [0]    OBU-version-request,
    obu-version-response        [1]    OBU-version-response,
    obu-info-request            [2]    OBU-info-request,
    obu-info-response           [3]    OBU-info-response,
    obu-register-inform         [4]    OBU-register-inform,
    obu-register-acknowledge     [5]    OBU-register-acknowledge,
    bt-zone-exit-inform         [6]    BT-zone-exit-inform,
    bt-zone-exit-acknowledge     [7]    BT-zone-exit-acknowledge,
    bt-zone-entry-inform        [8]    BT-zone-entry-inform,
    bt-zone-entry-acknowledge    [9]    BT-zone-entry-acknowledge,
}
ICC-MessageType ::= CHOICE {
    icc-power-on-request        [0]    ICC-power-on-request,
    icc-power-on-response       [1]    ICC-power-on-response,
    icc-power-off-request       [2]    ICC-power-off-request,
    icc-power-off-response      [3]    ICC-power-off-response,
    icc-apdu-exchange-request   [4]    ICC-APDU-exchange-request,
    icc-apdu-exchange-response  [5]    ICC-APDU-exchange-response,
    icc-apdu-exchange-stop-request [6]  ICC-APDU-exchange-stop-request,
    icc-apdu-exchange-stop-response [7]  ICC-APDU-exchange-stop-response,
}
    
```

```
icc-info-query-request      [8]  ICC-info-query-request,  
icc-info-query-response    [9]  ICC-info-query-response,  
icc-reload-query-request   [10] ICC-reload-query-request,  
icc-reload-query-response  [11] ICC-reload-query-response,  
}
```

Annex D (informative)

Other possible tolling models

D.1 General

As essential tolling models performed by DSRC-OBE connected to external in-vehicle devices that are described in [Clause 5](#), other possible tolling models are introduced in [Annex D](#). Furthermore, mobile payment and “Touch and Go” payment without DSRC-OBE are also introduced for references.

Touch and Go payment method, simplified EFC performed with transaction processing between payment means and roadside reader, is introduced widely in Asian countries because of low installation cost and no-OBE required.

D.2 DSRC-assisted mobile payment

Anonymous mobile payment is performed by connecting DSRC-OBE and a mobile phone with a payment function that has prevailed in the markets.

Functions and process flows are described below.

- a) Charge amount is determined by transaction exchanges between DSRC-OBE and RSE.
- b) Determined charge amount is transferred to external in-vehicle devices.
- c) Charge amount is deducted from payment means imbedded in external in-vehicle devices.
- d) External in-vehicle devices transfer payment information to DSRC-OBE and mobile service provider through CN as well.

Anonymous payment is performed because payment should be done for Toll charger without identifying user directly. See [Figures D.1](#) and [D.2](#).

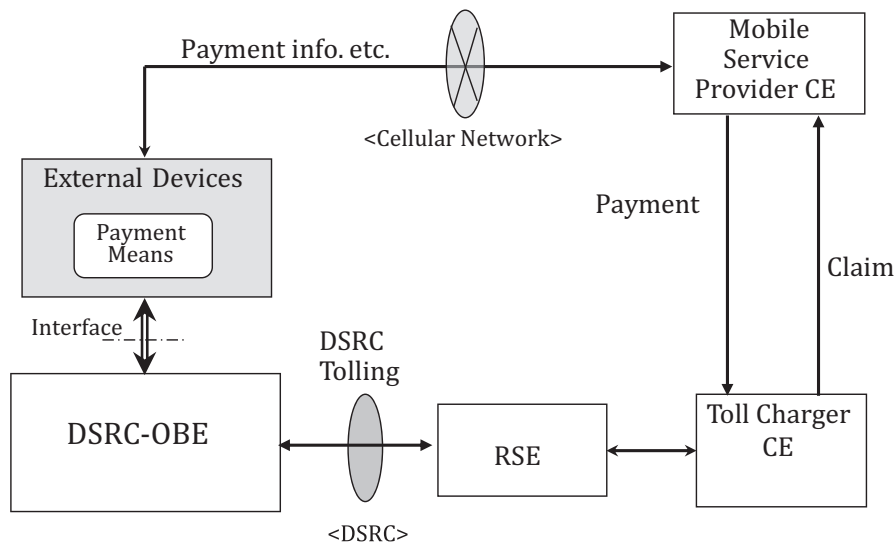

Figure D.1 — DSRC-assisted mobile payment

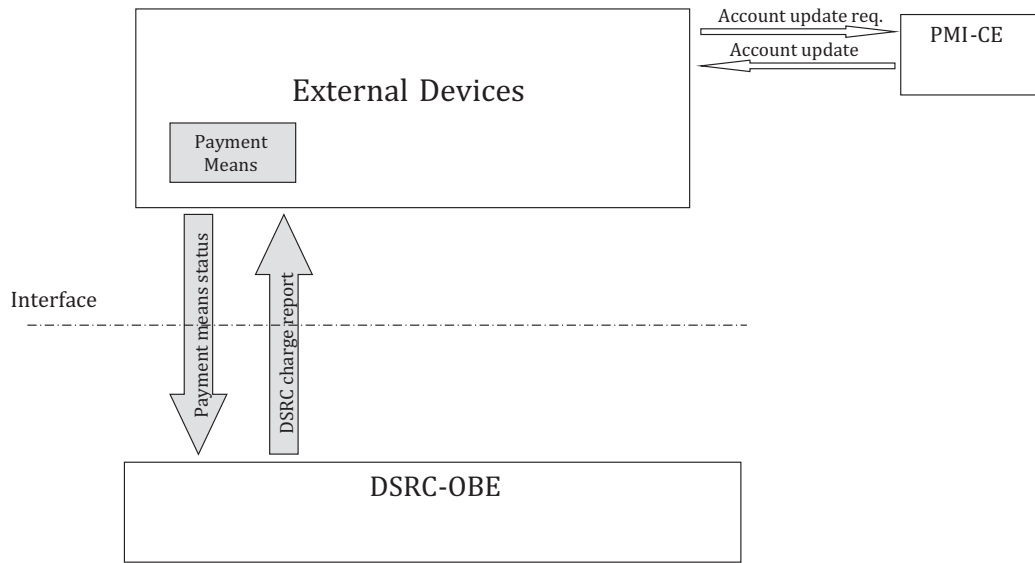

Figure D.2 — Message flows for DSRC-assisted mobile payment

D.3 Mobile payment

Mobile payment is simplified DSRC-assisted mobile payment and the functions and process flows are described below and shown in [Figure D.3](#).

- a) Charge amount is determined by transaction exchanges between external in-vehicle devices and RSE through NFC interface.
- b) Determined charge amount is deducted from payment means imbedded in external in-vehicle devices.
- c) External in-vehicle devices transfer payment information to mobile service provider through CN.

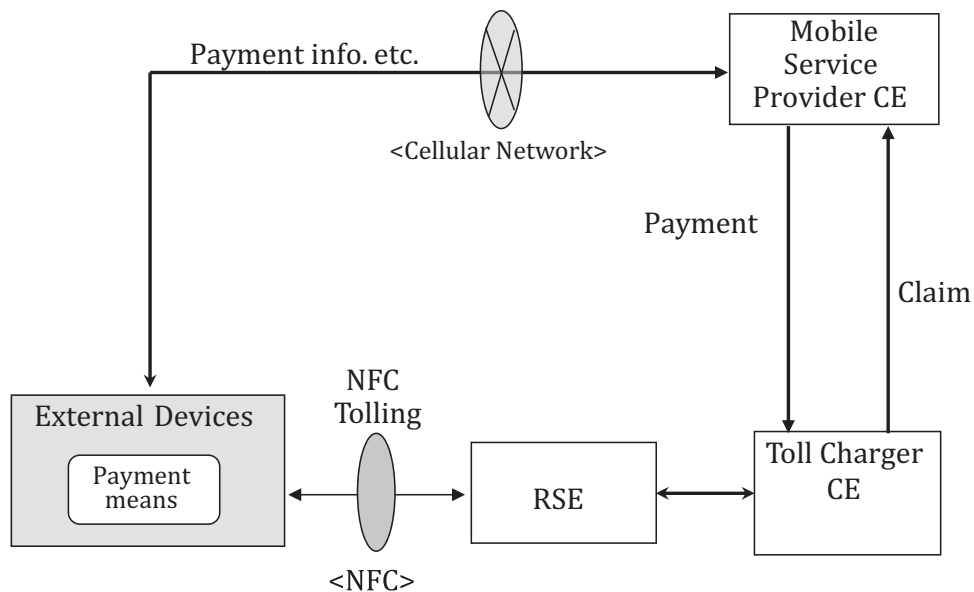

Figure D.3 — Mobile payment

D.4 Touch and Go payment

The most simplified EFC is Touch and Go payment in which user handles the payment means to touch the RSE. Payment means should have NFC interface. Touch and Go payment is introduced in Asian countries such as Malaysia, Korea, etc. as simplified EFC along with on-board account EFC.

In case of low balance or near low balance, payment means should be reloaded by the terminal installed at a toll plaza or service area along toll roads or contracted shops and so on. See [Figure D.4](#).

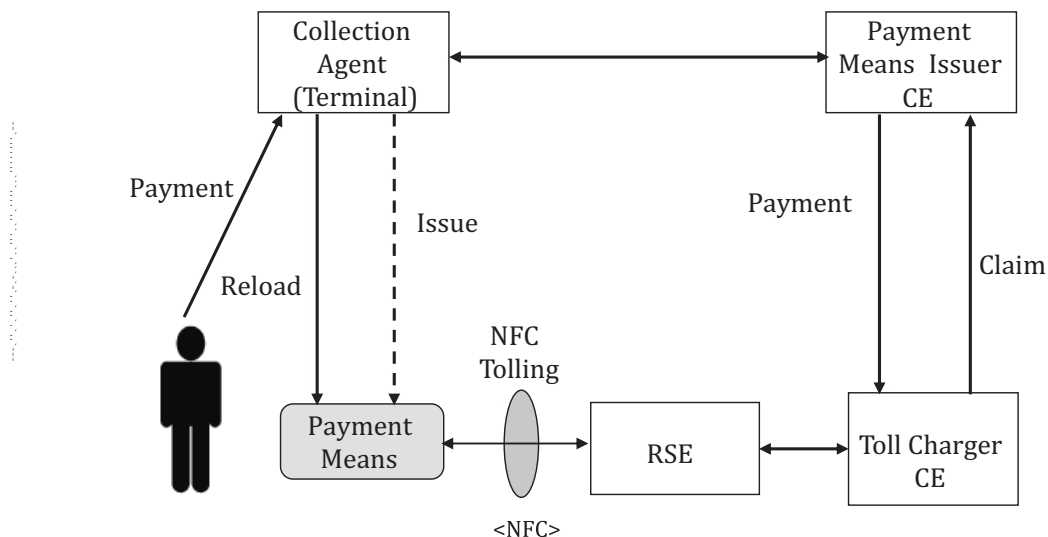

Figure D.4 — Touch and Go payment

Annex E (informative)

Applicable ITS services

E.1 Applicable ITS services with external in-vehicle devices

Applicable ITS services supported by several combinations of DSRC-OBE and external in-vehicle devices are shown in [Table E.1](#). As an example, ITS services in Japan are introduced briefly hereinafter.

Table E.1 — Applicable ITS services with external in-vehicle devices

| ITS services | | DSRC-OBE | Components of external in-vehicle devices ^a | | | | | | | Adapted for (plan) |
|-----------------------------|------------------------------|----------|--|-----------|-----|----------------|--------------------|-----------------------|--------------------------------|--------------------|
| | | | GNSS | CN module | HMI | Motion sensors | Digital tachograph | Driver records device | Driving licence reading device | |
| 1. Tolling services | Basic DSRC tolling | M | | | | | | | | Globally |
| | Mobile-assisted DSRC tolling | M | | M | | | | | | KR-ETC |
| | Universal tolling | M | M | M | M | M | O | | | O Globally |
| | DSRC-assisted mobile payment | M | | M | | | | | | |
| 2. Road traffic information | Probe information | M | M | | | M | | | | JP-ITS |
| | Dynamic route guidance | M | | | M | | | | | JP-ITS |
| | Traffic information | M | | | M | | | | | JP-ITS |
| 3. Safety assisting | Curve speed warning | M | | | M | | | | | JP-ITS |
| | Obstacle detection warning | M | | | M | | | | | JP-ITS |

CAN: Controller Area Network, **EV:** Electric Vehicle, **JP:** Japan, **KR:** Korea, **TARV:** Telematics Application for Regulated commercial Vehicles. M: Mandatory, O: Option

^a Exclude software module such as Proxy for tolling and any application module.

Table E.1 (continued)

| ITS services | | DSRC-OBE | Components of external in-vehicle devices ^a | | | | | | | Adapted for (plan) | |
|-----------------------------------|------------------------------|----------|--|-----------|-----|----------------|--------------------|-----------------------|--------------------------------|--------------------|--------------|
| | | | GNSS | CN module | HMI | Motion sensors | Digital tachograph | Driver records device | Driving licence reading device | | CAN bus unit |
| 4.Regulated commercial operations | Remote tachograph monitoring | M | M | M | | | M | | | | (TARV) |
| | Driver work records | M | M | M | | | | M | | | (TARV) |
| | Vehicle speed monitoring | M | M | M | | | | | M | | (TARV) |
| 5.EV management | EV charge amount monitoring | M | M | M | | | | | | M | JP-EV |
| | Charge station guidance | M | M | M | | | | | | | JP-EV |
| 6.Others | Drive through payment | M | | | | M | | | | | (JP-ITS) |

CAN: Controller Area Network, **EV:** Electric Vehicle, **JP:** Japan, **KR:** Korea, **TARV:** Telematics Application for Regulated commercial Vehicles. M: Mandatory, O: Option

^a Exclude software module such as Proxy for tolling and any application module.

E.2 ITS service in Japan

ITS services have been introduced with a step-by-step approach in Japan since the early 1990s. The first popular service is road guidance service provided by a car navigation device which provides road information to drivers for cruise assistance. The next service is Vehicle Information and Communication System (VICS) which provides traffic information and other road-related information on a car navigation device for drivers via DSRC using 2,45 GHz band. The third service is ETC which has prevailed nationwide now, and then those services are integrated by the new DSRC-OBE model which has dual-DSRC access port, one is for ETC and the other is for the new VICS using 5,8 GHz band same as ETC.

The system diagram of the integrated ITS services in Japan is shown in [Figure E.1](#) and the internal diagram of a new DSRC-OBE is shown in [Figure E.2](#). New ITS services in Japan are shown in [Figure E.3](#).

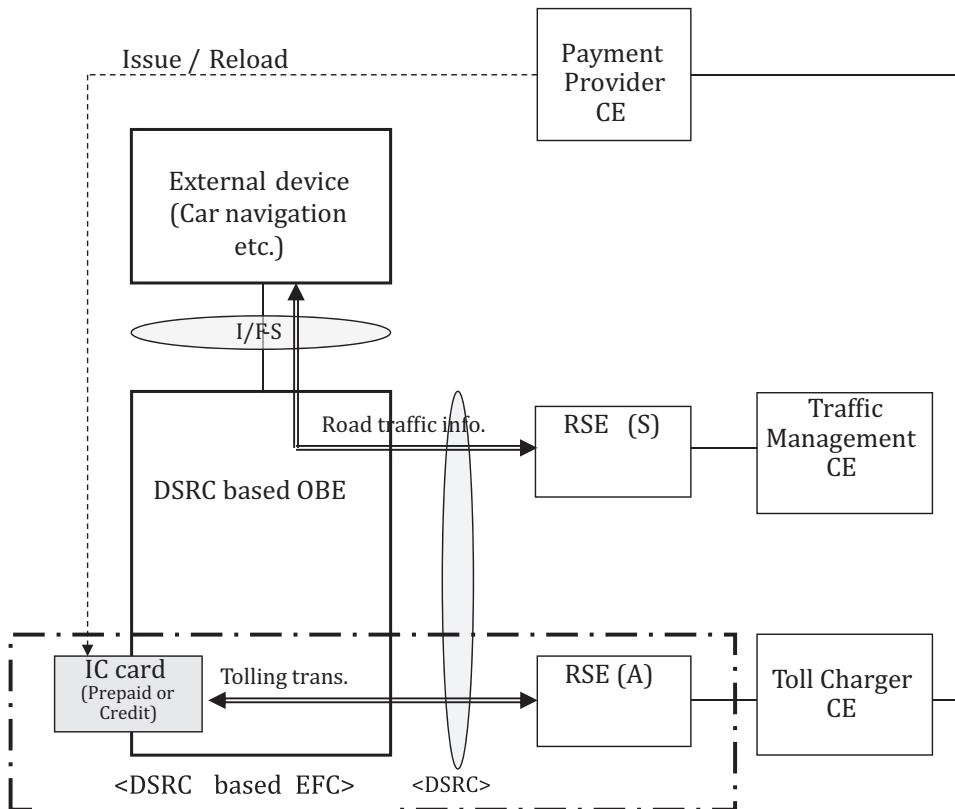

Key

- RSE (A) support DSRC-based tolling communication
- RSE (S) support road traffic information

Figure E.1 — System diagram of the integrated ITS services in Japan

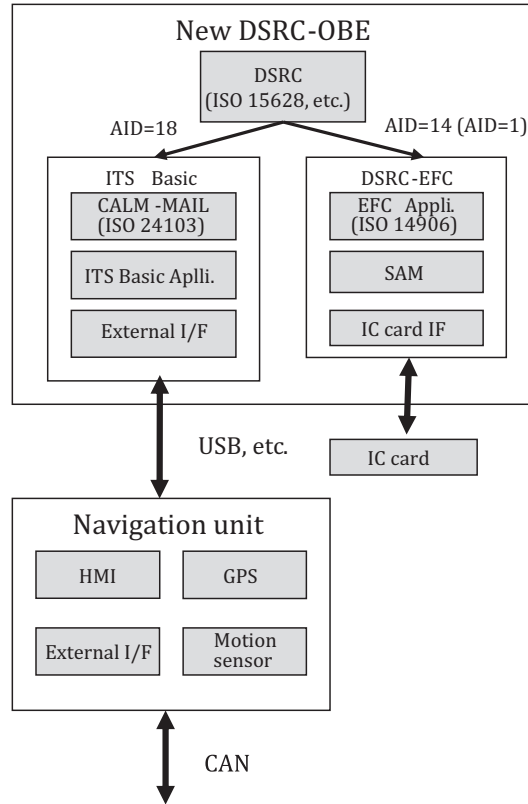

Figure E.2 — Internal diagram of new DSRC-OBE



Figure E.3 — New ITS services in Japan

Information on this page is intentionally left blank.

Bibliography

- [1] CEN/TS 16439:2012¹⁾, *Electronic Fee Collection — Security Framework*
- [2] ISO/TS 25110:2013, *Electronic fee collection — Interface definition for on-board account using integrated circuit card (ICC)*

1) ISO/TS 19299 with the same title is a new project and under development.

.....

